

TU

TECHNISCHE UNIVERSITÄT WIEN

DISSERTATION

Coding Sequences

Combinatorial, geometric and topological aspects

ausgeführt zum Zwecke der Erlangung des akademischen Grades
eines Doktors der technischen Wissenschaften unter der Leitung

von

Ao. Univ. Prof. Dr. Reinhard Winkler

E104

Institut für Diskrete Mathematik und Geometrie

eingereicht an der Technischen Universität Wien
Fakultät für Mathematik und Geoinformation

von

Christian Steineder

Josef Bühl Gasse 29

1230 Wien



Wien, am 24. September 2005

Kurzzusammenfassung

Eine irrationale Zahl α legt die Folge $(n\alpha)_{n=1}^{\infty} \bmod 1$ fest, welche in $[0, 1)$ gleichmäßig gleichverteilt ist, d.h. die Folge erfüllt

$$\lim_{N \rightarrow \infty} \frac{|\{n \in \{k, k+1, \dots, N-1\} : n\alpha \bmod 1 \in I\}|}{N} = b - a$$

gleichmäßig in $k \in \mathbb{Z}$, wobei $I = [a, b) \subseteq [0, 1)$ ein beliebiges Intervall ist. Diese Tatsache beruht auf Resultaten aus Hermann Weyl's bedeutender Arbeit *Über die Gleichverteilung von Zahlen mod. Eins* ([43]), die als Ausgangspunkt für die Entwicklung der Theorie der Gleichverteilung angesehen werden kann. Eng verbunden mit der Theorie der Gleichverteilung sind die der ergodischen Abbildungen und der dynamischen Systeme. Die sogenannte Kodierungsfolge von I , $\mathbf{a} = (a_k)_{k=-\infty}^{\infty} \in \{0, 1\}^{\mathbb{Z}}$, ist definiert durch

$$a_n = \begin{cases} 1 & \text{falls } n\alpha \bmod 1 \in I, \\ 0 & \text{sonst.} \end{cases}$$

Neben anderen interessanten Eigenschaften findet sich in dieser Kodierungsfolge auch die gleichmäßige Gleichverteilung der zugrundeliegenden $n\alpha$ -Folge wieder. Damit nimmt sie eine besondere Stellung in der symbolischen Dynamik ein. Als fruchtbare Verallgemeinerung dieser Situation etablierte sich die Theorie der Hartman Mengen und Hartman Folgen.

In der vorliegenden Dissertation werden kombinatorische, ergodentheoretische, geometrische und topologische Zusammenhänge zwischen Hartman Mengen beziehungsweise Hartman Folgen und zugrunde liegender kodierter Menge untersucht. Die so gewonnenen Erkenntnisse finden Anwendung in verwandten Problemen.

Kapitel 1 beginnt mit einer Einführung in die Theorie der topologischen Gruppen und in die Ergodentheorie. Anschließend wird das Konzept der Hartman Mengen und Hartman Folgen vorgestellt. Weiters wird die Komplexitätsfunktion besprochen. Es folgt eine Untersuchung von Hartmanfolgen mit maximaler Komplexität. Ist die kodierte Menge eine Teilmenge von $[0, 1)$, so ermöglicht die Theorie der Kettenbrüche eine genauere Strukturanalyse der Kodierungsfolge. Dies wird am Ende von Kapitel 1 ausgeführt.

Kapitel 2 beschäftigt sich mit Bohr Mengen, welche bereits in Kapitel 1 als wichtige Objekte auftreten. Zunächst wird eine asymptotische Formel für das Wachstum der Komplexitätsfunktion der entsprechenden Hartmanfolge bewiesen. Es stellt sich heraus, dass der von Bohrmengen erzeugte Filter ein wertvolles Hilfsmittel für die Charakterisierung von Untergruppen lokalkompakter abelscher Gruppen ist. Tatsächlich kann gezeigt werden, dass es zu jeder abzählbaren Untergruppe H einer kompakten metrisierbaren topologischen Gruppe G eine Folge $(\chi_n)_{n=1}^{\infty}$ von Elementen der zu G dualen Gruppe \widehat{G} gibt, sodass

$$\alpha \in H \quad \iff \quad \lim_{n \rightarrow \infty} \chi_n(\alpha) = 0.$$

Dies erweitert das Hauptresultat von [12], welches zu jeder abzählbaren Untergruppe H der Kreisgruppe die Existenz einer Folge $(k_n)_{n=1}^{\infty}$ ganzer Zahlen garantiert, welche $\lim_{n \rightarrow \infty} k_n \alpha = 0$ genau dann wenn $\alpha \in H$ erfüllt. Auch werden neue Möglichkeiten der Charakterisierung von Untergruppen präsentiert, sowie Probleme von Dikranjan et al. behandelt. Der letzte Abschnitt dieses Kapitels widmet sich der Frage welche Informationen über die kodierte Menge aus der induzierten Hartman Folge entnommen werden können. Basierend auf [44] werden diesbezügliche Aspekte diskutiert.

Schließlich werden in Kapitel 3 Hartman Folgen betrachtet, welche durch ein Polytop P induziert werden. Es wird eine asymptotische Formel für die Komplexität solcher Hartmanfolgen berechnet. Es zeigt sich ein direkter Zusammenhang mit der Geometrie von P . Falls P konvex ist stellt sich heraus, dass die asymptotische Komplexität (fast immer) mit dem Volumen des Projektionskörpers von P übereinstimmt. Diese Tatsache klärt, wie sich die Geometrie der kodierten Menge auf das Wachstumsverhalten der Komplexität auswirkt.

Die zentralen Teile dieser Arbeit sind in [7] (Abschnitt 1.5), [8] (Abschnitt 2.2), [38] (Kapitel 3) und [40] (Abschnitte 1.4.2, 1.4.3 und 2.1) enthalten.

Am Beginn jeder Sektion finden sich Referenzangaben zu dem jeweiligen Themenkreis.

Diese Dissertation wurde unterstützt durch den Österreichischen Wissenschaftsfonds FWF im Rahmen der Projekte Nr. S8312 und Nr. S8302.

Abstract

An irrational number α induces the sequence $(n\alpha)_{n=1}^{\infty} \bmod 1$, which is well distributed in $[0, 1)$, i.e. the identity

$$\lim_{N \rightarrow \infty} \frac{|\{n \in \{k, k+1, \dots, N-1\} : n\alpha \bmod 1 \in I\}|}{N} = b - a$$

holds uniformly in $k \in \mathbb{Z}$, where $I = [a, b) \subseteq [0, 1)$ is an arbitrary interval. This fact is based on results of Hermann Weyl's celebrated paper *Über die Gleichverteilung von Zahlen mod. Eins* ([43]) which can be seen as a starting point of the theory of uniform distribution. Closely related to the theory of uniform distribution are ergodic theory and topological dynamics. The so called coding sequence of I , $\mathbf{a} = (a_k)_{k=-\infty}^{\infty} \in \{0, 1\}^{\mathbb{Z}}$, is given by

$$a_n = \begin{cases} 1 & \text{if } n\alpha \bmod 1 \in I, \\ 0 & \text{otherwise.} \end{cases}$$

It is an interesting property of this coding sequence that it displays the well distribution of the corresponding $n\alpha$ -sequence. Hence it is a special object of symbolic dynamics. A fruitful generalization of this situation has been developed in the theory of Hartman sets and Hartman sequences.

In the present thesis, combinatorial, ergodic, geometric and topological connections among Hartman sets, Hartman sequences and their corresponding coded sets are investigated. Also related problems are studied.

Chapter 1 starts with an introduction to the theory of topological groups and ergodic theory. The concept of Hartman sets and Hartman sequences is developed, and the complexity function is introduced. Next, Hartman sequences of maximal complexity are studied. If the coded set is a subset of $[0, 1)$, the theory of continued fractions allows a detailed analysis of the structure of the coding sequence. This is done at the end of Chapter 1.

Chapter 2 deals with Bohr sets which already have an important position in Chapter 1. At first, an asymptotic formula for the growth rate of the complexity function of Hartman sequences corresponding to Bohr sets is shown. The filter generated by Bohr sets turns out to be a useful tool for the

characterization of subgroups of locally compact abelian groups. In fact, it will be shown that for every countable subgroup H of a compact metrizable abelian group G there exists a sequence $(\chi_n)_{n=1}^{\infty}$ of elements of \widehat{G} , the dual group of G , such that

$$\alpha \in H \quad \Longleftrightarrow \quad \lim_{n \rightarrow \infty} \chi_n(\alpha) = 0.$$

This extends the main result of [12] which guarantees for every countable subgroup H of the circle group the existence of a sequence $(k_n)_{n=1}^{\infty}$ of integers such that $k_n \alpha \rightarrow 0$ if and only if $\alpha \in H$. Moreover a different way of characterization of subgroups will be presented and several problems of Dikranjan et al. will be discussed. The last part of this chapter is dedicated to the question which information of the coded set is contained in the induced Hartman sequence. Based on [44], several aspects concerning this question will be treated.

Finally, in Chapter 3, Hartman sequences induced by a polytope P are treated. An asymptotic formula for the complexity of such sequences is computed. This formula indicates a direct connection to the geometry of P . It turns out that if P is convex, then the asymptotic complexity coincides (in almost all cases) with the volume of the projection body of P . This fact clarifies how the geometry of the coded set influences the growth rate of the complexity function.

The central parts of this work are contained in [7] (Section 1.5), [8] (Section 2.2), [38] (Chapter 3) and [40] (Sections 1.4.2, 1.4.3 and 2.1).

At the beginning of each section we shall indicate references to the actual topic.

The research for this thesis was supported by the Austrian Science Foundation through projects no. S8312 and no. S8302.

Personal Note

I want to express my gratitude to several persons who supported me during the research for this thesis.

First of all I thank my colleagues and friends Mathias Beiglböck, Gabriel Maresch and Franz Schuster for the help so generously given, lots of patience and amicable advice. I thank specifically Franziska Berger for her detailed criticism, contributed comments and numerous corrections which substantially improved this work.

I am grateful to Professor Michael Drmota for supporting me within his FWF project no. S8302. Moreover, I am grateful to the members of the research unit Convex and Discrete Geometry at the TU Vienna for accepting me so warmly at their department.

I want to thank Professor Valérie Berthé for reading the first version of this thesis so carefully and patiently and for amending remarks and suggestions.

In particular, I am indebted to my supervisor Professor Reinhard Winkler for his mathematical and personal support during my years of study, for many interesting conversations, for asking me the right questions which lead to this thesis and for helping me to answer them. Moreover, I want to express my gratitude for the possibility to work in his FWF research project no. S8312.

Finally I want to express my heartfelt thanks to my family and to Theodora Kapellou for the most important thing - for their love.

In the end an advice for the reader: If you get tired of Hartman sequences while reading this thesis, have a break and listen to John Coltrane and Johnny (the real) Hartman.

Contents

Kurzzusammenfassung	1
Abstract	3
Personal Note	5
1 Entrée	9
1.1 General background	9
1.1.1 Topological groups and duality theory	10
1.1.2 Ergodic theory	13
1.1.3 Monothetic groups	18
1.2 Hartman sets and sequences	19
1.3 Complexity	22
1.4 Complexity and Hartman sequences	24
1.4.1 A general criterion and some consequences	25
1.4.2 A universal upper bound for the complexity of Hartman sequences	26
1.4.3 A Hartman sequence of arbitrarily subexponential complexity	30
1.5 One dimensional Hartman sequences	31
2 Aspects and applications of Bohr sets	38
2.1 Complexity and Bohr sets	38
2.2 Characterization of subgroups	45
2.2.1 Introduction	45
2.2.2 Further conventions and notation	46
2.2.3 Characterizing filters	47
2.2.4 Characterizing countable subgroups	49

2.2.5	Thick and thin characterizing sequences	55
2.2.6	Groups as sets of convergence	57
2.3	Reconstruction of Hartman sequences	61
2.3.1	The abstract approach	61
2.3.2	Comments on the function f_M	63
2.3.3	Bohr sets and explicit reconstruction	65
3	Complexity induced by polytopes	68
3.1	Notation	68
3.1.1	Polytopes in \mathbb{T}^d	69
3.1.2	Partition sets and local complexity	70
3.1.3	Independence of $P \subseteq \mathbb{T}^d$ and $\alpha \in \mathbb{T}^d$	71
3.1.4	Definition of a measure preserving mapping	72
3.1.5	The separation number	75
3.1.6	The projection body	76
3.2	Main result	77
3.3	Proof of Proposition 3.2.3	79
3.3.1	Overview	79
3.3.2	A basic lemma	80
3.3.3	Coverings of the boundary of $P \subseteq \mathbb{T}^d$ and hyperplanes intersecting C	84
3.3.4	Consequences of Lemma 3.3.3 and σ' -asymptotic inde- pendence	88
3.3.5	Asymptotic growth rate of the number of intersecting d -tuples induced by $\mathcal{H}^i(D, N, W)$	93
3.3.6	Finalizing the Proof	96
3.4	The asymptotic independence of P and α	98
3.5	Further remarks	100
	Bibliography	101
	Curriculum Vitae	105

Chapter 1

Entrée

1.1 General background

In this section we explain the notation and basic facts on which this text is mainly based.

As usual, $\mathbb{T} = \mathbb{R}/\mathbb{Z}$ denotes the circle (torus) group. For $x \in \mathbb{R}$, $\|x\|$ denotes the distance to the nearest integer (i.e. the distance to 0 in \mathbb{T}).

If X is a topological space and $Y \subseteq X$ we write \bar{Y} , Y° and ∂Y for the closure, interior and the boundary of Y . In the sequel, compact X always satisfy Hausdorff's separation axiom.

Let X be a topological space, B the Borel σ -algebra on X and μ a measure on X . Then we call X a measure space. As usual $L^p(\mu)$ denotes the space of all (equivalence classes of) functions f for which $|f|^p$ is integrable.

If G is a group and H a subgroup of G , we write $H \leq G$. We are only dealing with abelian groups, consequently we shall always use additive notation. If $A \subseteq G$ is a subset of G , we write $\langle A \rangle$ for the subgroup generated by A .

Instead of the phrase "if and only if" we sometimes write abbreviating "iff".

1.1.1 Topological groups and duality theory

[18], [27], [29]

Let G be a locally compact abelian (LCA) group. We set

$$\widehat{G} = \{\chi : G \rightarrow \mathbb{T} : \chi \text{ is a continuous homomorphism}\}.$$

Define as binary operation on \widehat{G} the pointwise addition $(\chi_1 + \chi_2)(x) = \chi_1(x) + \chi_2(x)$, $x \in G$, χ_1 and χ_2 in \widehat{G} , in the torus group. Then \widehat{G} is also an abelian group. Furthermore, it can be equipped with a topology. The appropriate topology for our needs is the so called compact open topology. An open basis at the identity in this topology consists of all sets $U(K, \varepsilon) \subseteq \widehat{G}$ which are defined by

$$U(K, \varepsilon) = \left\{ \chi \in \widehat{G} : \|\chi(x)\| \leq \varepsilon \text{ for all } x \in K \right\},$$

where $K \subseteq G$ is compact, and $\varepsilon > 0$.

Definition 1.1.1 \widehat{G} equipped with the compact open topology is called the dual group of G . Its elements $\chi \in \widehat{G}$ are called characters.

The dual group of an LCA group is itself an LCA group. Thus it is natural to define the dual group of \widehat{G} , the bidual group of G , which is of course also an LCA group. But much more holds true. The striking Duality Theorem of Pontryagin and van Kampen shows that G and $\widehat{\widehat{G}}$ are essentially the same object.

Theorem 1.1.2 Let $x \in G$ be a fixed element. Let

$$x' : \widehat{G} \rightarrow \mathbb{T}; \quad x'(\chi) = \chi(x).$$

Then the mapping τ defined by $\tau(x) = x'$ is a topological isomorphism of G onto $\widehat{\widehat{G}}$.

Example 1.1.3 The most common example for a topological group in the context of Duality theory is $G = \mathbb{T}$ equipped with the usual topology. Then $\widehat{G} = \mathbb{Z}$. This example will play a central role in the sequel. The Duality Theorem implies $\widehat{\widehat{G}} \cong \widehat{\mathbb{Z}} \cong \mathbb{T}$.

The next assertion, partly a consequence of the Duality Theorem, tells us more about the connection between the topologies on G and \widehat{G} .

Theorem 1.1.4 *Let G be an LCA group. Then*

$$\begin{aligned} G \text{ is discrete} &\Leftrightarrow \widehat{G} \text{ is compact.} \\ G \text{ is compact} &\Leftrightarrow \widehat{G} \text{ is discrete.} \end{aligned}$$

Theorem 1.1.4 has an important consequence – it indicates how to construct compactifications of LCA groups.

Definition 1.1.5 *Let G be an LCA group. We call the pair (C, ι) a compactification of G if $\iota : G \rightarrow C$ is a (not necessarily injective) continuous homomorphism and $\iota(G)$ is dense in the compact group C .*

Let (C_1, ι_1) and (C_2, ι_2) be compactifications of G . We write $(C_1, \iota_1) \preceq (C_2, \iota_2)$ and call (C_1, ι_1) a factor of (C_2, ι_2) if there exists a continuous homomorphism π such that the diagram

$$\begin{array}{ccc} & & C_2 \\ & \nearrow \iota_2 & \downarrow \pi \\ G & \xrightarrow{\iota_1} & C_1 \end{array}$$

commutes. If $(C_1, \iota_1) \preceq (C_2, \iota_2)$ and $(C_2, \iota_2) \preceq (C_1, \iota_1)$ we write $(C_1, \iota_1) \cong (C_2, \iota_2)$. Then \preceq is a partial order relation on the set $\mathcal{C} = \mathcal{C}(G)$ of all equivalence classes of compactifications of G w.r.t. \cong .

Let G be an LCA group and \widehat{G} its dual group. Let

$$\iota_B : G \rightarrow \mathbb{T}^{\widehat{G}} = \prod_{\chi \in \widehat{G}} \mathbb{T}_\chi, \quad \iota_B(g) = (\chi(g))_{\chi \in \widehat{G}}.$$

Then ι_B is a continuous homomorphism and

$$bG = \overline{\iota_B(G)} \quad (\text{in } \mathbb{T}^{\widehat{G}})$$

is, due to Tychonoff's Theorem, a compact group. (bG, ι_B) is called the Bohr compactification of G . It turns out that (bG, ι_B) is a maximal element in \mathcal{C}

w.r.t. the partial ordering \preceq . The duality theory implies that $bG \cong \widehat{\widehat{G}_d}$. Here \widehat{G}_d denotes the dual group of G endowed with the discrete topology. Moreover, there is a 1-1 correspondence between subgroups of $A \leq \widehat{G}$ and factors of bG . The compactification $(C_A, \iota_A) \preceq (bG, \iota_B)$, where

$$\iota_A : G \rightarrow \prod_{\chi \in A} \mathbb{T}_\chi, \quad \iota_A(g) = (\chi(g))_{\chi \in A},$$

and $C_A = \overline{\iota_A(G)}$ in $\prod_{\chi \in A} \mathbb{T}_\chi$ directly corresponds to $A \leq \widehat{G}$.

LCA groups also enjoy a very important and nice measure theoretic property. A measure μ on G is called invariant if for every measurable $B \subseteq G$ and every $g \in G$, $\mu(g + B) = \mu(B)$.

Definition and Theorem 1.1.6 *Let G be an LCA group. Then there exists an invariant Borel measure μ on G , called the Haar measure. μ is uniquely determined up to a positive factor. In particular, if G is compact, there exists a unique Haar measure μ with $\mu(G) = 1$.*

We finish this section by listing some further results in light of topological groups and duality theory.

1. If G is compact, then the members of \widehat{G} form an orthonormal basis for $L^2(\mu)$ where μ is the Haar measure.
2. If H is a closed subgroup of G and $H \neq G$, there exists a nontrivial $\chi \in \widehat{G}$ such that $\chi(h) = 0$ for all $h \in H$.
3. Let $H \subseteq G$. Then the annihilator $A(\widehat{G}, H)$ of H in \widehat{G} is defined by

$$A(\widehat{G}, H) = \left\{ \chi \in \widehat{G} : \chi(h) = 0 \text{ for all } h \in H \right\}.$$

If H is a closed subgroup of an LCA group, then

- (a) $\widehat{G/H} \cong A(\widehat{G}, H)$.
- (b) $\widehat{H} \cong \widehat{G}/A(\widehat{G}, H)$.
- (c) $H = A(G, A(\widehat{G}, H))$.

\cong denotes here topological isomorphism.

4. Let the weight $w(x)$ of the topological space X be the minimal cardinality of an open base of X . If G is a locally compact group then $w(G) = w(\widehat{G})$. An LCA group G is metrizable iff G has a countable base and thus iff \widehat{G} has a countable base. In particular, if G is compact, then \widehat{G} is discrete and thus G is metrizable iff \widehat{G} is countable.
5. Let G be an abelian topological T_0 group (i.e. for all $x, y \in G$ with $x \neq y$ there exists an open set $U \subseteq G$ containing only either x or y). If G is metrizable, then the metric d compatible with its topology can be chosen to be invariant (i.e. for arbitrary $x, y, g \in G$ holds $d(x, y) = d(gx, gy) = d(xg, yg)$).
6. Let G be a topological group and $H \leq G$. If H and G/H have a countable base, so does G .

1.1.2 Ergodic theory

[14], [42]

We shall give a brief overview about concepts and results from ergodic theory that are connected to our topic.

Let X be a probability space with measure μ . Let T be a measure preserving transformation on X (i.e. for all measurable sets $A \subseteq X$ holds $\mu(A) = \mu(T^{-1}(A))$).

Definition 1.1.7 *A measure preserving mapping T is called ergodic if all measurable sets E with $T^{-1}(E) = E$ satisfy $\mu(E) = 0$ or 1.*

Ergodic mappings have remarkable properties. We start with the so called Ergodic Theorem.

Theorem 1.1.8 *Let T be a measure preserving mapping on the probability space X and let $f \in L^1(\mu)$. Then $\frac{1}{N} \sum_{n=1}^N f(T^n(x))$ converges to a function $f^* \in L^1(\mu)$ for almost all $x \in X$. Furthermore $f^* = f^* \circ T$ almost everywhere and $\int_X f(x) d\mu = \int_X f^*(x) d\mu$.*

Remark 1.1.9 It is a direct consequence of ergodicity that, if T is ergodic, $f^* = f^* \circ T$ almost everywhere implies that f^* is constant. Thus $f^* =$

$1/\mu(X) \int_X f(x)d\mu$ almost everywhere and hence

$$\lim_{N \rightarrow \infty} \frac{1}{N} \sum_{n=1}^n f(T^n(x)) = \frac{1}{\mu(X)} \int_X f(x)d\mu$$

almost everywhere.

We focus now on the special case where $X = G$ is a compact abelian group.

Theorem 1.1.10 1. *The transformation $T : x \mapsto x + a$ on \mathbb{T} is ergodic if and only if a is irrational.*

2. *Let G be a compact abelian group (with Haar measure μ) and let $a \in G$. Then the transformation $T : x \mapsto x + a$ on G is ergodic if and only if $(na)_{n \geq 1}$ is dense in G .*

Remark 1.1.11 Theorem 1.1.10 in combination with Theorem 1.1.8 gives a weak form of the well known Weyl criterion applied to $n\alpha$ sequences. (Cf. for instance [39] for an overview on this topic.)

To present another nice aspect of (ergodic) transformations $T : x \mapsto x + a$ acting on a compact abelian groups, in the sequel also called (ergodic) group translations, we need further notation.

Let again T be a measure preserving mapping on the probability space X with measure μ . Then T induces a linear operator $U_T : L^2(\mu) \rightarrow L^2(\mu)$, $U_T(f) = f(T(x))$. U_T is an isometry. We call a complex number λ an eigenvalue of U_T if $U_T(f) = \lambda f$. f is the corresponding eigenfunction. It is easy to see that $|\lambda| = 1$.

Definition 1.1.12 *An ergodic measure preserving mapping T acting on a probability space X is said to have discrete spectrum if there exists an orthonormal basis of $L^2(\mu)$ consisting of eigenfunctions of U_T .*

For an introduction to the spectral theory of the operator U_T we refer to [42]. Ergodic group translations have discrete spectrum:

Theorem 1.1.13 *Let $T : x \mapsto x + a$ be an ergodic translation on a compact abelian group G . Then T has discrete spectrum. Every eigenfunction is a constant multiple of a character, and the eigenvalues of T are $\{\chi(a) : \chi \in \widehat{G}\}$.*

Moreover, we have the following fact related to the factors of the Bohr compactification introduced in Section 1.1.1.

Theorem 1.1.14 *Every subgroup $A \leq \mathbb{T}$ is the group of eigenvalues of an ergodic group translation T .*

Next we introduce a few basic concepts of topological dynamics. These are topological counterparts to the measure theoretic ergodic theory.

Instead of measure preserving mappings on a probability space we deal with continuous mappings on a compact metric space. We focus now on (topological) group translations, i.e. mappings $T : x \mapsto x + a$ acting continuously on a compact metric group G . In the sequel $C(X)$ denotes the set of complex valued continuous functions f on X

Definition 1.1.15 *A homeomorphism $T : X \rightarrow X$ is called minimal if $\{T^n x : n \in \mathbb{Z}\}$ is dense in X for all $x \in X$.*

Theorem 1.1.16 *A group translation $T : x \mapsto x + a$ is minimal if and only if $\{na : n \in \mathbb{Z}\}$ is dense in G .*

The last theorem indicates that ergodic group translations and topological group translations are closely related. As in the measure theoretical context there exists also a concept of topological discrete spectrum which is essentially similar to the one introduced above. But topological group translations have a further remarkable property.

Definition 1.1.17 *A continuous transformation $T : X \rightarrow X$ on a compact metric group is called uniquely ergodic if there exists only one invariant Borel probability measure on X .*

Thus, compact metric abelian groups are uniquely ergodic – their unique translation invariant probability measure is the normalized Haar measure. For uniquely ergodic transformations we have the following theorem.

Theorem 1.1.18 *Let $T : X \rightarrow X$ be a continuous transformation on a compact metric space. Then the following statements are equivalent:*

1. $\frac{1}{N} \sum_{n=0}^{N-1} f(T^n x)$ converges uniformly to a constant for every $f \in C(X)$.

2. $1/N \sum_{n=0}^{N-1} f(T^n x)$ converges pointwise to a constant for every $f \in C(X)$.

3. There exists a T -invariant probability measure μ on X such that

$$1/N \sum_{n=0}^{N-1} f(T^n x) \rightarrow \int_X f(x) d\mu$$

for every $x \in X$ and every $f \in C(X)$.

4. T is uniquely ergodic.

Thus, for group translations on a compact metric group, the ergodic theorem holds not only almost everywhere but for all x uniformly. This fact is directly connected to the theory of uniform distribution of monothetic groups. We give a short introduction in Section 1.1.3.

At the end of the present section we turn to another topic of ergodic theory related to our investigations, namely the concept of entropy. We start with the measure theoretic entropy:

Let X be a probability space. As usual, a partition of X is a set of disjoint sets whose union is X . We are interested in finite partitions. Let $A = \{A_1, \dots, A_N\}$ and $B = \{B_1, \dots, B_M\}$ be two finite partitions. Then,

$$A \vee B = \{A_i \cap B_j : 1 \leq i \leq N, 1 \leq j \leq M\}$$

is again a partition, the join partition of A and B .

Let $T : X \rightarrow X$ be a measure preserving transformation on the probability space X with measure μ . If $A = \{A_1, \dots, A_N\}$ is a finite partition of X , we write

$$H(A) = - \sum_{i=1}^N \mu(A_i) \log(\mu(A_i)) \quad \text{and}$$
$$h(T, A) = \lim_{n \rightarrow \infty} \frac{1}{n} H \left(\bigvee_{i=0}^{n-1} T^{-i} A \right).$$

Definition 1.1.19 *If $T : X \rightarrow X$ is a measure preserving transformation on the probability space X , then the entropy of T , $h(T)$, is defined by $h(T) = \sup h(T, A)$ where the supremum is taken over all finite partitions of X .*

As a matter of fact, $h(T) \in [0, \infty]$. For the special case of group translations, we know the following.

Theorem 1.1.20 *Any ergodic translation of a compact abelian group has entropy zero.*

As before, there exists an analogue to the concept of entropy in topological dynamics:

Let X be a compact space. We are now interested in finite open covers. Let $A = \{A_1, \dots, A_N\}$ and $B = \{B_1, \dots, B_M\}$ be two finite open covers. Then, as before, the join of these two open covers $A \vee B$ is the open cover given by all sets of the form $A_i \cap B_j$, for $A_i \in A$ and $B_j \in B$.

If A is an open cover of the compact space X , then $\mathcal{N}(A)$ denotes the number of sets in a finite subcover of A with smallest cardinality. Let $T : X \rightarrow X$ be a continuous map. Then we set, similar to the above,

$$H(A) = \log(\mathcal{N}(A)) \quad \text{and}$$

$$h(T, A) = \lim_{n \rightarrow \infty} \frac{1}{n} H \left(\bigvee_{i=0}^{n-1} T^{-i} A \right).$$

Definition 1.1.21 *If $T : X \rightarrow X$ is a continuous transformation acting on the compact space X , then the topological entropy of T , $h(T) = h_{\text{top}}(T)$ is given by $h(T) = \sup h(T, A)$ where the supremum is taken over all open covers of X .*

It can be shown directly that group translations have topological entropy zero. This follows also from the Variation Principle, which nicely connects topological and measure theoretic entropy:

Theorem 1.1.22 *Let $T : X \rightarrow X$ be a continuous map of a compact metric space X . Then*

$$h_{\text{top}}(T) = \sup \{h_{\mu}(T) : \mu \in M(X, T)\},$$

where $M(X, T)$ is the space of all probability measures on X which are preserved by T .

1.1.3 Monothetic groups

[18], [27], [29]

As announced, we turn to a special class of topological groups.

Definition 1.1.23 *A topological group G which contains a dense cyclic subgroup is called monothetic.*

It is easy to see that monothetic groups are always abelian. According to Theorem 1.1.10, the concept of monothetic groups is directly related to the theory of ergodic (topological) group translations. We are mostly interested in compact monothetic groups. Using duality theory, it can be proven that a compact group G is monothetic if and only if $\widehat{G} \leq \mathbb{T}$.

Compact monothetic groups have important properties related to the theory of uniform distribution.

Definition 1.1.24 *Let X be a compact space and μ a regular normed Borel measure on X . Then we call a sequence $(x_n)_{n=1}^{\infty}$ in X μ -well distributed in X if*

$$\lim_{N \rightarrow \infty} \frac{1}{N} \sum_{n=h+1}^{N+h} f(x_n) = \int_X f(x) d\mu$$

holds for every continuous real valued function f defined on X uniformly in $h \in \mathbb{Z}$.

By unique ergodicity of ergodic group translations the next result follows.

Theorem 1.1.25 *If the sequence $(ng)_{n=1}^{\infty}$ is dense in the compact group G (i.e. if g generates G) then it is well distributed in G (w.r.t. the Haar measure).*

Finally let $G = \mathbb{Z}(\alpha_1, \dots, \alpha_d) \bmod 1$. Then $G = \mathbb{T}^d$ iff the α_i , $i = 1, \dots, d$, are linearly independent over \mathbb{Q} . This is equivalent to the fact that the transformation $T : x \mapsto x + g$, $g = (\alpha_1, \dots, \alpha_d)$, is ergodic. According to Theorem 1.1.25, the sequence $(ng)_{n=1}^{\infty}$ is even well distributed. (Again we point out the relation to Weyl's criterion, see [43]).

Remark 1.1.26 \mathbb{T} has no order structure. But \mathbb{T} can be interpreted as unit interval $[0, 1) \subseteq \mathbb{R}$ after identifying $0 = 1$. Due to this fact, we call

(connected) sets in \mathbb{T} which are (translates of) intervals in $[0, 1)$, so before identifying, again intervals in \mathbb{T} . The same can be done in $\mathbb{T}^d = \mathbb{R}^d/\mathbb{Z}^d$. In fact, sets $M \subseteq \mathbb{T}^d$ which are translates (in \mathbb{T}^d) of corresponding sets $M' \subseteq [0, 1)^d$ before identifying opposite sides will play a central role in the sequel. In particular we call a set $M \subseteq \mathbb{T}$ a box, a polytope, a convex set, etc. if its corresponding set $M' \subseteq [0, 1)^d$, interpreted as subset of the Euclidean space \mathbb{R}^d is a box, a polytope, a convex set, etc..

1.2 Hartman sets and sequences

[7], [22], [32], [33], [35], [40], [44]

The aim of this section is to introduce the concept of Hartman sets and Hartman sequences in the case $G = \mathbb{Z}$ and present several preliminary results.

If $G = \mathbb{Z}$, then $\widehat{G} = \mathbb{T}$, i.e. each character χ is of the form

$$\chi(k) = k\alpha \pmod{1},$$

where $\alpha \in \mathbb{T}$. Clearly each compactification of \mathbb{Z} has to be monothetic. Following Section 1.1, the Bohr compactification of \mathbb{Z} is the dual group of \mathbb{T}_d (\mathbb{T} endowed with the discrete topology) or, equivalently, the closure of $\{(k\alpha)_{\alpha \in \mathbb{T}, k \in \mathbb{Z}}\}$ in $\mathbb{T}^{\mathbb{T}}$. As indicated above, each subgroup $A \leq \mathbb{T}$ induces a compactification (C_A, ι_A) by setting $\iota_A : \mathbb{Z} \rightarrow \mathbb{T}^A$; $\iota_A(k) = (k\alpha)_{\alpha \in A}$. If $A = \langle \alpha_1, \dots, \alpha_d \rangle$, and the α_i , $i = 1, \dots, d$, are linearly independent over \mathbb{Q} , then we call (C_A, ι_A) a d -dimensional compactification of \mathbb{Z} . Let in particular (C_α, ι_α) be the compactification determined by $\iota_\alpha(k) = k\alpha$. We define π_{α_0} to be the projection of $b\mathbb{Z}$ onto C_{α_0} , i.e. $(x_\alpha)_{\alpha \in \mathbb{T}} \mapsto x_{\alpha_0}$.

Let G be an LCA group and μ its unique normalized Haar measure.

Definition 1.2.1 A set $M \subseteq G$ with $\mu(\partial M) = 0$ is called *continuity set*.

We focus on continuity sets that are subsets of $b\mathbb{Z}$.

Remark 1.2.2 The continuity sets are generalized Jordan measurable sets. More precisely, on $b\mathbb{Z}$ we have the following situation:

Since the underlying topology is the product topology, the base sets of the Bohr compactifications are of the form

$$B(I_{\alpha_1}, \dots, I_{\alpha_d}) = \left\{ (k\alpha)_{\alpha \in \mathbb{T}} \in b\mathbb{Z} : \begin{array}{l} k\alpha_i \in I_{\alpha_i} \text{ for all} \\ i \in \{1, \dots, d\} \end{array} \right\},$$

where I_{α_i} are open intervals (open connected subsets) in \mathbb{T}_{α_i} (the α_i 's component). These sets are clearly continuity sets and can be interpreted as finite dimensional boxes (finite products of connected components). Let $\varepsilon > 0$. Since the Haar measure μ_b is regular, every continuity set M can be approximated by a compact set K and an open set E such that $\mu_b(E \setminus K) \leq \varepsilon$ and $K \subseteq O \subseteq \bar{O} \subseteq M^\circ \subseteq \bar{M} \subseteq E$, O open in $b\mathbb{Z}$. Compactness guarantees that there are finitely many base sets $B_l \subseteq M^\circ$, $l = 1, \dots, L_1$, which cover \bar{O} and $B'_l \subseteq E$, $l = 1, \dots, L_2$, which cover $\bar{M} \setminus O$. Set

$$B^1 = \bigcup_{l=1}^{L_1} B_l \quad \text{and} \quad B^2 = \bigcup_{l=1}^{L_2} B'_l.$$

Then $\overset{B^1}{B^1 \cup B^2}$ is a finite union of boxes giving an inner approximation of M and $\mu_b(B^2 \setminus B^1) \leq \varepsilon$.

Continuity sets can also be defined in compactifications (C_A, ι_A) , $A \leq \mathbb{T}$, that are factors of $b\mathbb{Z}$. Then M can be extended to $b\mathbb{Z}$ by setting $M = \mathbb{T}_\alpha$ in all components \mathbb{T}_α of $b\mathbb{Z}$ with $\alpha \in \mathbb{T} \setminus A$. Conversely, for $M \subseteq b\mathbb{Z}$, let $A(M)$ be the subgroup generated by

$$A_0(M) = \{\alpha \in \mathbb{T} : \pi_\alpha(M) \subsetneq \mathbb{T}\}.$$

Then we call $(C_{A(M)}, \iota_{A(M)})$ the minimal compactification of M since it only consists of those components where M is nontrivial.

Let (C, ι) be an arbitrary compactification. The set of all continuity sets $M \subseteq C$ forms a Boolean set algebra. A continuity set M induces a set $H = \iota^{-1}(M) \subseteq \mathbb{Z}$. Since the compact group C is a monothetic group it can also be interpreted as ergodic group translation $T : x \mapsto x + \iota(1)$. This approach allows to define the so called coding sequence of M , i.e., a binary biinfinite sequence $\mathbf{a} = \mathbf{a}(M) = (a_k(M))_{k=-\infty}^{\infty} \in \{0, 1\}^{\mathbb{Z}}$, via

$$a_k = \begin{cases} 1 & \text{if } k\iota(1) \in M, \\ 0 & \text{otherwise.} \end{cases}$$

If $\mathbf{1}_H$ denotes the characteristic function of H , then obviously $\mathbf{1}_H = \mathbf{a}$.

Definition 1.2.3 A coding sequence \mathbf{a} of a continuity set M is called a Hartman sequence. The corresponding set $H \subseteq \mathbb{Z}$ is called a Hartman set.

The set of all Hartman sets also forms a Boolean set algebra \mathcal{H} . On \mathcal{H} we can define a (finitely additive) measure by setting

$$\mu(H) = \mu_b(M) \text{ if } H = \iota_B^{-1}(M).$$

That this measure is well defined follows from the fact that, for continuity sets M_1 and M_2 in $b\mathbb{Z}$, $H = \iota_B^{-1}(M_1) = \iota_B^{-1}(M_2)$ implies $\mu_b(M_1) = \mu_b(M_2)$.

This measure μ on \mathcal{H} has a remarkable property which is of central importance to us.

Theorem 1.2.4 For $H \in \mathcal{H}$,

$$\mu(H) = \text{dens}(H) = \lim_{N \rightarrow \infty} \frac{|\{n \in H \cap \{k, k+1, \dots, k+N-1\}\}|}{N}$$

holds uniformly in $k \in \mathbb{Z}$.

Sketch of Proof: As indicated in Remark 1.2.2 each continuity set can be approximated arbitrarily well by finite unions of finite products of intervals. Thus each approximation depends only on finitely many components of $b\mathbb{Z}$ and Theorem 1.1.25 implies the assertion. For more details see [22]. ■

In terms of Hartman sequences this means the following:

If, for $\mathbf{a} = (a_n(M))_{n \in \mathbb{Z}} = \mathbf{1}_H$, $A_k(N)$ denotes the number of occurrences of 1's in the block $a_k a_{k+1} \dots a_{k+N-1}$ of length N , there exists a bound $c_M(N) = o(1)$, $N \rightarrow \infty$, such that

$$\left| \frac{A_k(N)}{N} - \mu_C(N) \right| \leq c_M(N)$$

for all $k \in \mathbb{N}$.

Before we present some examples of Hartman sequences, let us point out a further consequence of the Jordan measurability of continuity sets (cf. [44]).

Theorem 1.2.5 For every Hartman set H there exists a metrizable compactification (C, ι) and a continuity set $M \subseteq C$ such that $H = \iota^{-1}(M)$.

Recall that C is metrizable iff the subgroup $A \leq \mathbb{T}$ corresponding to C is countable. Having this in mind, the last theorem verifies the natural conjecture that a Hartman set (as a countable object) has to be generated by a continuity set that is nontrivial in at most countably many components of $b\mathbb{Z}$.

Example 1.2.6 Every finite set is a Hartman set.

Coding sequences of intervals or of boxes are Hartman sequences. In fact they are basic Hartman sequences in the sense that finite unions of them approximate other Hartman sequences arbitrarily well.

A different type of example is given by Hadamard sets (also called lacunary sequences). These are infinite sets of natural numbers $\{a_i : i \in \mathbb{N}\}$ for which there exists a $\lambda > 1$ such that $\frac{a_{i+1}}{a_i} > \lambda$. Such sets are Hartman sets corresponding to a continuity set of measure 0. The same holds for sets $\{p(n) : n \in \mathbb{N}\}$, where p is a nonlinear polynomial. For both examples exist constructions of compactifications with infinitely many nontrivial components in which the corresponding continuity sets can be realized in. (Cf. [22] for the polynomial and [35] for the lacunary case.)

Remark 1.2.7 A detailed study of the concept of Hartman sets and Hartman sequences over general LCA groups can be found in [32] and [33]. The authors also introduce and investigate so called Hartman functions which can be seen as a generalization of almost periodic functions.

1.3 Complexity

[3], [9], [23], [24], [25], [26]

Let $\mathbf{a} = (a_k)_{k=-\infty}^{\infty}$ in $\{0, 1\}^{\mathbb{N}}$ or $\{0, 1\}^{\mathbb{Z}}$ be an arbitrary binary (bi-)infinite sequence. To emphasize that we interpret such a sequence as an object of symbolic dynamics, we also call \mathbf{a} an infinite word. For $N \in \mathbb{N}$, a block

$$w = a_i a_{i+1} \dots a_{i+N-1} \in \{0, 1\}^N$$

occurring in \mathbf{a} at position $i \in \mathbb{Z}$ will be called (finite) subword or factor of the word \mathbf{a} . Its length will be denoted by $|w|$.

Definition 1.3.1 *The complexity (function), also called the n -th permutation number, $P_{\mathbf{a}}(n)$, is the number of distinct subwords of length n occurring in \mathbf{a} .*

This concept was introduced in [23]. There is a direct connection to the so called entropy. Interpret \mathbf{a} as an element of the compact space $X = \{0, 1\}^{\mathbb{Z}}$. Let, for $x = (x_k)_{k=-\infty}^{\infty}$ and $y = (y_k)_{k=-\infty}^{\infty}$,

$$c(x, y) = \min \{|k| \in \mathbb{N} : x_k \neq y_k\} \quad \text{and} \quad d(x, y) = \frac{1}{1 + c(x, y)}.$$

Then d respects the (product) topology on X and (X, d) is a compact metric space. Let furthermore $\sigma : X \rightarrow X$, $\sigma(x_n) = x_{n+1}$ be the classical shift yielding the dynamical system (X, σ) . Let $O(\mathbf{a})$ denote the orbit closure of \mathbf{a} under σ in X (i.e. $O(\mathbf{a}) = \overline{\{\sigma^k(\mathbf{a}) : k \in \mathbb{Z}\}} \subseteq \{0, 1\}^{\mathbb{Z}}$). Then

$$h_{top}(\mathbf{a}, \sigma) = \lim_{n \rightarrow \infty} \frac{\log(P_{\mathbf{a}}(n))}{n},$$

where $h_{top}(\mathbf{a}, \sigma)$ denotes the topological entropy of the transformation σ acting on $O(\mathbf{a})$. This indicates that the complexity can be interpreted as a refinement of the topological entropy.

The complexity function can be defined for any finite alphabet $\mathcal{A} = \{a_1, a_2, \dots, a_n\}$. In our case $\mathcal{A} = \{0, 1\}$ we immediately get the trivial bounds $1 \leq P(n) \leq 2^n$. A first easy result (see for instance [25]) indicates how the complexity of a sequence \mathbf{a} is related to its structure.

Theorem 1.3.2 *Let \mathbf{a} be a binary (bi-)infinite word. Then the following assertions are equivalent:*

1. \mathbf{a} is purely periodic (ultimately periodic if \mathbf{a} is a one sided infinite word).
2. $P_{\mathbf{a}}(n)$ is bounded.
3. $P_{\mathbf{a}}(n) \leq n$ for an $n \in \mathbb{N}$.
4. $P_{\mathbf{a}}(n+1) = P_{\mathbf{a}}(n)$ for an $n \in \mathbb{N}$.

Theorem 1.3.2 indicates that complexity is related to periodicity. Non-periodic sequences have at least complexity $P(n) \geq n + 1$.

Definition 1.3.3 A binary (bi-)infinite and not ultimately periodic word \mathbf{a} with $P_{\mathbf{a}}(n) = n + 1$ is called *Sturmian word*.

Sturmian words are well studied objects with several remarkable properties. The most important ones for our purpose will be investigated in the next section. First we present a different characterization as well as two examples for Sturmian words.

1. Sturmian sequences are the non (ultimately) periodic balanced words over a two letter alphabet. A word \mathbf{a} is called balanced if the number of occurrences of a letter in any two subwords of \mathbf{a} of the same length differs at most by one in absolute value.
2. Let $l : y = \alpha x + \lambda$, $\alpha, \lambda \in \mathbb{R}$, be a line in \mathbb{R}^2 . Starting at any point $(x_0, y_0) \in l$ we define its so-called cutting sequence by increasing $x \geq x_0$ and concatenating

$$\begin{array}{ll} 0 & x \in \mathbb{Z} \text{ and } y \in \mathbb{R} \setminus \mathbb{Z} \\ 1 & \text{whenever } (x, y) \in l \text{ and } x \in \mathbb{R} \setminus \mathbb{Z} \text{ and } y \in \mathbb{Z} . \\ 10 & x, y \in \mathbb{Z} \end{array}$$

Such cutting sequences define Sturmian words if $\alpha \in \mathbb{R} \setminus \mathbb{Z}$. A related definition can be obtained using square billiard sequences.

3. A substitution is a mapping from an alphabet into the set of finite words on this alphabet. Let $\sigma(0) = 01$ and $\sigma(1) = 0$ be the Fibonacci substitution. Clearly this substitution can be extended to a mapping on binary words. Starting with $w_0 = 0$ let $w_n = \sigma(w_{n-1})$. Then the word $w = \lim_{n \rightarrow \infty} w_n$ in $\{0, 1\}^{\mathbb{Z}}$ endowed with the product topology is a Sturmian word, called the Fibonacci word.

1.4 Complexity and Hartman sequences

[1], [2], [3], [9], [25], [35]

Per definition, Hartman sequences are binary biinfinite words. What can be said about the complexity of Hartman sequences? In this chapter we treat this question.

If \mathbf{a} is a Hartman sequence corresponding to the continuity set $M \subseteq (C, \iota)$, we will write $P_{M, \iota}(\bar{n})$ instead of $P_{\mathbf{a}}(\bar{n})$ to point out the connection to the corresponding coded continuity set.

Note that finite compactifications always induce periodic Hartman sequences. As we know the complexity of such Hartman sequences is always bounded. Thus the more interesting case is the one of an infinite compactification.

1.4.1 A general criterion and some consequences

[1], [2], [35]

Following [35], we first present a general criterion: Let (C, ι) be a compactification of \mathbb{Z} and $\alpha = \iota(1)$ the generating element of C . Let $M \subseteq C$ be a continuity set. Let $\mathbf{a} = \mathbf{a}(M, \iota)$ be the Hartman sequence corresponding to M . Let $w = w_0 w_1 \dots w_{N-1}$ be any binary word of length N . Obviously w is a factor of \mathbf{a} if there exists some $i \in \mathbb{Z}$ such that $(i+l)\alpha \in M$ if and only if $w_l = 1$ (i.e. iff there exists an $i \in \mathbb{Z}$ such that $a_{i+l} = w_l$, $l = 0, \dots, N-1$). This is equivalent to

$$i\alpha \in M(w) = \bigcap_{l=0}^{N-1} (M^l - l\alpha),$$

where $M^l = M$ if $a_l = 1$ and $M^l = C \setminus M$ otherwise.

Note that by density such an i exists whenever $M(w)$ contains an open set. Since $M(w)$ is even a continuity set the word w occurs in \mathbf{a} with uniform frequency $\mu_C(M(w))$.

This criterion immediately allows to compute the complexity of Hartman sequences stemming from an interval and an irrational α – such Hartman sequences will be called one dimensional Hartman sequences.

Let I be any interval on the torus (open, closed, halfopen) with boundary points a and b . (In fact, the subsequent idea also works for coding sequences of a finite union of intervals.) Each $w \in \{0, 1\}^N$ defines the set

$$P_w = \bigcap_{i=1}^N (I^i - i\alpha),$$

where $I^i = I$ if $a_i = 1$ and $I^i = \mathbb{T} \setminus I$ otherwise. If $a \neq b + k\alpha$, for all $k \in \mathbb{Z}$, a geometric argument shows that, for N sufficiently large, each P_w which occurs is an interval of positive length. Moreover, the number of nonempty P_w equals $2N$. Thus by the criterion presented at the beginning of this section $P_I(N) = 2N$. (See [1] for a details.) If I is halfopen and if there exists an $k \in \mathbb{Z}$ such that $b = a + k\alpha$, then the same argument shows that $P_I(n) = n + k$ for $n \geq k$. This implies in particular the following assertion .

Theorem 1.4.1 *The coding sequence of a halfopen interval $I \subseteq \mathbb{T}$ by an irrational α is a Sturmian sequence if and only if $|I| \in \{\alpha, 1 - \alpha\}$.*

Remark 1.4.2 Let C be a compactification of \mathbb{Z} . Remark 1.2.2 shows that for every $\varepsilon > 0$, every continuity set M can be approximated by two sets M_i , $i = 1, 2$, which are finite unions of finite products of intervals $I_{\alpha_j} \subseteq \mathbb{T}_{\alpha_j}$ such that $M_1 \subseteq M \subseteq M_2$ and $\mu_C(M_2 \setminus M_1) \leq \varepsilon$. Moreover, each interval $I_\alpha \subseteq \mathbb{T}_\alpha$ can be written as a finite union of finite intersections of intervals of lengths α inducing Sturmian words. Therefore for each Hartman set H and for every $\varepsilon > 0$, there exists a Hartman set H' induced by a finite union of finite intersections of Sturmian sequences such that $\text{dens}(H \setminus H') \leq \varepsilon$.

Coding sequences yielding Sturmian words are (aperiodic) Hartman sequences of minimal complexity. It is natural to ask for upper bounds of the complexity of Hartman sequences.

1.4.2 A universal upper bound for the complexity of Hartman sequences

[40]

At first glance the definition of topological entropy and the general criterion presented in Section 1.4.1 seem to be directly connected. Since $h_{\text{top}}(T) = 0$ for an ergodic group translation T , one conjectures that the complexity of a coding sequence is subexponential. The following easy example shows that this does not hold in general.

Example 1.4.3 Let $\mathbf{a} = (a_n)_{n=1}^\infty$ be the concatenation of the binary expansions of all natural numbers (i.e. take the digits of Champernown's number

0.12345...). Let $g = \iota(1)$ be the generating element of any infinite compactification (C, ι) of \mathbb{Z} . Let $A = \{k \in \mathbb{N} : a_k = 1\}$ and $S = Ag \subseteq C$. The coding sequence of S is \mathbf{a} and $P_{\mathbf{a}}(n) = 2^n$.

Clearly, S is no continuity set (otherwise A had a uniform density). For Hartman sequences, the above conjecture holds. Before presenting a direct proof of the next theorem we sketch how $h(T) = 0$ can be applied to obtain a proof of it based on the strong Variation Principle (see Theorem 1.1.22). We will also discuss why $h_{top}(T) = 0$ does not help immediately. The insights obtained in this way motivate our idea of the direct proof.

Theorem 1.4.4 *For any compactification (C, ι) of \mathbb{Z} and any continuity set $M \subseteq C$ the complexity $P_{\mathbf{a}}(n)$ of the corresponding Hartman sequence $\mathbf{a} = \mathbf{1}_H$ with $H = \iota^{-1}(M)$ satisfies*

$$\lim_{n \rightarrow \infty} \frac{\log P_{\mathbf{a}}(n)}{n} = 0.$$

Sketch of proof using the Variation Principle: The Hartman sequence \mathbf{a} induces the topological space $X = \overline{O(a)_\sigma} \subseteq \{0, 1\}^{\mathbb{Z}}$. We must show that the topological entropy of the shift w.r.t. this space is 0. The density of the subwords of \mathbf{a} implies a so-called block distribution (this concept is introduced and studied in [35]) which can be uniquely extended to a measure ν on X . The measure theoretic entropy of the underlying group translation is 0. Hence also the measure theoretic entropy of σ is 0 w.r.t. ν . Since Hartman sequences can be equipped with a uniform density the system (X, σ) is uniquely ergodic. Therefore, applying the Variation Principle, $h_{top}(\sigma) = h(\sigma) = 0$. ■

Before we present the direct proof of the last assertion, we discuss why $h_{top}(T) = 0$ cannot immediately be applied to the general criterion of Section 1.4.1.

Let d be a T invariant metric on C (w.l.o.g. we can assume that C is metrizable). According to the definition of the entropy we have to start with an open cover \mathcal{O} of the compact group C . For $\varepsilon > 0$, one natural candidate to obtain an estimation for the complexity would be, for instance,

$$A_\varepsilon = \{M^\circ, (X \setminus M)^\circ, \underbrace{\partial M + B_\varepsilon}_{=: \partial M_\varepsilon}\},$$

where B_ε denotes the open ball with center 0 and radius ε and $+$ denotes the complex sum. Following Section 1.1.2, $h_{top}(T)$ is given by

$$\lim_{n \rightarrow \infty} \frac{\log(\mathcal{N}(\bigvee_{i=0}^{n-1} T^{-i} A_\varepsilon))}{n}$$

for all $\varepsilon > 0$. For any open cover \mathcal{O} of C , $\mathcal{N}(\mathcal{O})$ denotes the number of open sets in a finite subcover of C with elements of \mathcal{O} of minimal cardinality.

Let \mathcal{O} be an arbitrary open cover of C . Let $\delta > 0$ be the Lebesgue number of \mathcal{O} (i.e. each subset of diameter less than δ is contained in one element of \mathcal{O} . Such a δ exists due to the Lebesgue covering lemma.) Let F be a $\delta/2$ spanning set of C , i.e. for all $c \in C$ there exists an $x \in F$ such that $d(c, x) \leq \delta/2$. Let $N(\delta) = |F|$. Assume that $x \in F$. Since T is an isometry (w.r.t. the metric d), $T^i(B(x, \delta/2))$ is contained in an element $A^i \in \mathcal{O}$ for all $i \in \mathbb{N}$. Thus, for all $n \in \mathbb{N}$, $\bigcap_{i=0}^{n-1} T^{-i}(A^i) \supseteq B(x, \delta/2)$. This holds for all $x \in F$. Hence

$$\mathcal{N}\left(\bigvee_{i=0}^{n-1} T^{-i} A_\varepsilon\right) \leq N(\delta)$$

holds for all $n \in \mathbb{N}$. Thus, the entropy $h_{top}(T)$ of a given partition actually only depends on the cardinality of a spanning set. It does not respect the contributions of the boundary of the partition sets to $h_{top}(\sigma)$.

For instance, using the open cover A_ε defined above for Example 1.4.3, clearly $\mathcal{N}(\bigvee_{i=0}^{n-1} T^{-i} A_\varepsilon) = 1$ for every $\varepsilon > 0$ and $n \in \mathbb{N}$. But as Example 1.4.3 shows, the boundary can even induce maximal complexity.

These observations show that all we must do is to understand how many sets P_w , given by the criterion introduced in Section 1.4.1, are contained in an open set of diameter $\delta > 0$. (Note that this is independent of the concept of entropy.) This is the idea the following proof is based on.

Direct proof: Let d be the metric for the topology on C . Let $g = \iota(1) \in C$ denote the generating element of the compactification.

We write M' for the complement $C \setminus M$ and M_δ for the set of all $x \in C$ with $d(x, y) < \delta$ for some $y \in M$. Fix $\varepsilon > 0$. Using the regularity of the Haar measure μ_C and the μ_C -continuity of M , we obtain $\mu_C(R) < \varepsilon$ for $R = (M_{\delta_1} \setminus M) \cup (M'_{\delta_1} \setminus M')$ whenever $\delta_1 > 0$ is sufficiently small. By a standard argument we may assume that R is a continuity set. At least one of the sets M and M' has nonempty interior. By symmetry, we may take

for granted that this is the case for M . Therefore there is some open ball B with center x and positive diameter $\delta < \delta_1/2$ with $B \subseteq M$. For the sake of simpler notation we assume $x = 0$.

Let W_l denote the set of all binary words $a_0 \dots a_{l-1}$ of length l with $a_k = 1$ whenever $kg + B \subseteq M$ and $a_k = 0$ whenever $kg + B \subseteq M'$.

By compactness of C , there is some $N_0 \in \mathbb{N}$ such that

$$C \subseteq \bigcup_{n=0}^{N_0-1} (-ng + B),$$

showing that for every $y \in C$ there is some $n \in \{0, 1, \dots, N_0 - 1\}$ with $y + ng \in B$.

Thus any word w of length $N_0 + l$ occurring in \mathbf{a} lies in some of the sets $W_{N_0+l,i}$, $0 \leq i \leq N_0 - 1$, consisting of all words

$$b_0 b_1 \dots b_{i-1} a_0 \dots a_{l-1} b_i \dots b_{N_0-1}$$

with $a_0 a_1 \dots a_{l-1} \in W_l$ and $b_0 b_1 \dots b_{N_0-1} \in \{0, 1\}^n$. Since $|W_{N_0+l,i}| = 2^{N_0} |W_l|$, this shows $P_{\mathbf{a}}(N_0 + l) \leq N_0 2^{N_0} |W_l|$.

Note that each translate $y + B$ is totally contained either in M or in M' whenever $y \notin R$. Thus, by the uniform distribution of $(ng)_n$ in C , the subset $T \subseteq \mathbb{Z}$ of all $k \in \mathbb{Z}$ such that $y = kg \notin R$ has density $\mu_C(C \setminus R) > 1 - \varepsilon$.

It follows that $|W_l| \leq 2^{2\varepsilon l}$, hence $P_{\mathbf{a}}(N_0 + l) \leq N_0 2^{N_0+2\varepsilon l}$ for l sufficiently large. This yields

$$\log P_{\mathbf{a}}(N_0 + l) \leq \log N_0 + (N_0 + 2\varepsilon l) \log 2$$

and, for $n = N_0 + l$,

$$\limsup_{n \rightarrow \infty} \frac{\log P_{\mathbf{a}}(n)}{n} \leq \limsup_{l \rightarrow \infty} \frac{\log N_0 + (N_0 + 2\varepsilon l) \log 2}{N_0 + l} \leq 2\varepsilon \log 2.$$

Since $\varepsilon > 0$ can be chosen arbitrarily small, this proves the theorem. ■

1.4.3 A Hartman sequence of arbitrarily subexponential complexity

[40]

We are going to show that the bound deduced in Theorem 1.4.4 is best possible.

Let (C, ι) be any infinite group compactification of \mathbb{Z} and $\phi : \mathbb{N} \rightarrow \mathbb{N}$. Suppose $\phi(n) = \varepsilon_n n \leq n$ with $\lim_{n \rightarrow \infty} \varepsilon_n = 0$. We have to show that there exists a continuity set $M \subseteq C$ such that the Hartman sequence $\mathbf{a} := \mathbf{1}_H$ with $H = \iota^{-1}(M)$ fulfills $P_{\mathbf{a}}(n) \geq 2^{\phi(n)}$.

By Theorem 1.2.5 it suffices to prove the assertion for metrizable C . By Section 1.1.1 there is an invariant metric d for the topology on C .

For $c \in C$, we write $\|c\| = d(c, 0)$. For each $n \in \mathbb{N}$ choose a subset $H^{(n)}$ of $\{0, \dots, n-1\}$ of cardinality $A_n \geq \varepsilon_n n$ and containing 0 such that the diameter d_n of $\iota(H^{(n)})$ is minimal. We claim that $\lim_{n \rightarrow \infty} d_n = 0$.

Otherwise, we can find a sequence $n_1 < n_2 < \dots$ and a $\delta > 0$ such that $d_{n_k} \geq 2\delta$ for all k . Further, there is some $r \in (0, \delta)$ such that the open ball B with center $0 \in C$ and radius r is a continuity set. By construction, the lower density of the set of all n with $\iota(n) \in B$ is at most ε_{n_k} for all k . By uniform distribution of $\iota(n)$, the lower density is a density and coincides with the Haar measure, hence $\mu(B) \leq \lim_{k \rightarrow \infty} \varepsilon_{n_k} = 0$. This contradicts the fact that nonempty open sets have positive measure.

Let now $H_n(0), H_n(1), \dots, H_n(2^{A_n} - 1)$ be an enumeration of all subsets of $H^{(n)}$. Define recursively $m_n(0) = 0$ and $m_n(i+1)$ to be the minimal integer $> m_n(i) + n$ such that $\|\iota(m_n(i+1))\| < d_n$. We put $H_n = \bigcup_{i=0}^{2^{A_n}-1} (m_n(i) + H_n(i))$. Obviously H_n is a finite set of nonnegative integers bounded by, say $h_n \in \mathbb{N}$. Observe furthermore that, by construction, $\|\iota(h)\| < 2d_n$ for all $h \in H_n$. Define, again recursively, $l_0 = 1$ and l_{n+1} to be the minimal integer $> l_n + h_n$ such that $\|\iota(l_{n+1})\| < d_n$. For the union $H = \bigcup_{n=0}^{\infty} (H_n + l_n)$ this implies $\lim_{n \rightarrow \infty, n \in H} \iota(n) = 0$. Thus, $M = \iota(H)$ is a countable closed subset of C with the only accumulation point 0, hence a continuity set of measure 0 and $H = \iota^{-1}(M)$ is a Hartman set.

In the corresponding Hartman sequence, each H_n induces at least 2^{A_n} different binary words of length n . Thus the complexity function $P(n)$ is

bounded from below by

$$P(n) \geq 2^{A_n} \geq 2^{\varepsilon n} = 2^{\phi(n)}.$$

This construction generates a zero set M . Hence each word in \mathbf{a} containing the letter 1 has asymptotic density 0. It would be nice to obtain a positive frequency for many words. Let therefore $M = \{0, m_1, m_2, \dots\}$ be an enumeration of M . There are $\delta_n > 0$ with $\delta_n \rightarrow 0$ such that balls B_n , $n \in \mathbb{N}$, with center m_n and radius δ_n are pairwise disjoint continuity sets. Replace M by the union of all B_n , which is again a continuity set. This shows:

Theorem 1.4.5 *Let (C, ι) be any infinite group compactification of \mathbb{Z} . Assume $\phi(n) \leq n$ and $\phi(n) = o(n)$ for $n \rightarrow \infty$. Then there exists a continuity set $M \subseteq C$ such that its Hartman sequence $\mathbf{a} := \mathbf{1}_{\iota^{-1}(M)}$ fulfills $P_{\mathbf{a}}(n) \geq 2^{\phi(n)}$. Furthermore, M can be chosen in such a way that for each $n \in \mathbb{N}$ at least $2^{\phi(n)}$ words of length n occur in \mathbf{a} with strictly positive density.*

1.5 One dimensional Hartman sequences

[7], [25], [35]

The aim of this section is to analyze the structure of Hartman sequences $H = \iota_{\alpha}^{-1}(M)$ where M is a connected subset of the torus.

Coding sequences generated by an $\alpha \in \mathbb{Q}$ are always periodic. The more interesting case is $\alpha \in \mathbb{T}^* = \mathbb{T} \setminus \mathbb{Q}/\mathbb{Z}$. The structure of coding sequences of intervals with an irrational α can be described in several ways. We mention a few of them.

Let $I = [a, b) \subseteq \mathbb{T}$ be an interval (observe that the subsequent computation works both for closed and open intervals). Let $\alpha \in \mathbb{T}$. Then

$$\begin{aligned} k\alpha \in I &\iff k\alpha - l \in [a, b) \text{ for an } l \in \mathbb{Z} \\ &\iff k\alpha \in [a + l, b + l) \text{ for an } l \in \mathbb{Z} \\ &\iff k \in \left[\frac{a+l}{\alpha}, \frac{b+l}{\alpha} \right) \text{ for an } l \in \mathbb{Z}. \end{aligned} \tag{1.1}$$

Thus,

$$H = \iota_{\alpha}^{-1}(I) = \bigcup_{n \in \mathbb{Z}} \{k_n, \dots, K_n\},$$

where $k_n = \lceil \frac{a+n}{\alpha} \rceil$ and $K_n = \lfloor \frac{b+n}{\alpha} \rfloor$. (Here, for $x \in \mathbb{R}$, we write $\lceil x \rceil$ ($\lfloor x \rfloor$) for the least integer greater or equal x (greatest integer less or equal x)).

If we have a Sturmian word induced by an interval $I = [b - \alpha, b)$ and a rotation angle α , equation (1.1) can be rewritten as

$$k\alpha \in I \iff k \in \frac{b+l}{\alpha} - [1, 0) \text{ for an } l \in \mathbb{Z},$$

i.e., the Hartman set H can be written as generalized arithmetic sequence $(\lfloor \frac{b+l}{\alpha} \rfloor)_{l \in \mathbb{Z}}$. Such sequences are called Beatty sequences. Thus, there is a one-to-one correspondence between Sturmian and Beatty sequences.

For a more detailed study of the structure of Hartman sequences induced by one dimensional compactifications, the theory of continued fractions turns out to be a powerful tool. Let $\alpha \in \mathbb{T}^*$. Then

$$\alpha = \frac{1}{a_1 + \frac{1}{a_2 + \dots}} = [0; a_1, a_2, \dots] = \lim_{n \rightarrow \infty} \frac{p_n}{q_n},$$

where $a_1, a_2, \dots \in \mathbb{N}$, $p_n = a_n p_{n-1} + p_{n-2}$, $p_{-1} = 1$, $p_{-2} = 0$ and $q_n = a_n q_{n-1} + q_{n-2}$, $q_{-1} = 0$, $q_{-2} = 1$. The fractions p_n/q_n are called convergents and the a_i are called partial quotients. The next theorem presents two basic facts of the theory of continued fractions.

Theorem 1.5.1 *Let $\alpha = \lim_{n \rightarrow \infty} \frac{p_n}{q_n}$. The sequence $(\{q_n \alpha\})_{n \geq 1}$ is best approximating in the sense that $\|l\alpha\| > \|q_{n-1} \alpha\|$, for all $l \in \{1, 2, \dots, q_n - 1\}$, ($n \in \mathbb{N}$). (As usual, $\{x\}$ denotes the fractional part of $x \in \mathbb{R}$.) Moreover, $\{q_{2n} \alpha\}$ ($\{q_{2n+1} \alpha\}$) tends to 0 from above (below).*

If $\alpha \in \mathbb{T}^*$ we can use Theorem 1.5.1 to define an ordering on \mathbb{N} which is directly related to the partition of \mathbb{T} induced by the multiples of α): Using the Ostrowski expansion of \mathbb{N} , we can write an $n \in \mathbb{N}$ as

$$n = \sum_{i=0}^{\infty} b_i(n) q_i =: (b_i(n))_{i \geq 0}^O,$$

where $b_0(n) \in \{0, 1, 2, \dots, a_1 - 1\}$ and, for $i \geq 1$,

$$b_i(n) \in \{0, 1, 2, \dots, a_{i+1} - 1, a_{i+1}\},$$

and $b_i(n) = a_{i+1}$ only if $b_{i-1}(n) = 0$.

(*)

A sequence $(b_i)_{i \geq 0}$ fulfilling the conditions (*) is called admissible w.r.t. α . As a matter of fact, for each $\beta \in \mathbb{T}$ there exists an admissible sequence $(V_n(\beta))_{n \geq 0}$ such that $\beta = \sum_{n=0}^{\infty} \{V_n(\beta)q_n\alpha\}$. This sequence is essentially unique (i.e. up to infinitely periodic expansions).

Let $(b_i)_{i \geq 0}$ and $(b'_i)_{i \geq 0}$ be two admissible sequences. We write $(b_i)_{i \geq 0} \prec (b'_i)_{i \geq 0}$ if there exists an $I \in \mathbb{N}$ such that

1. $b_i = b'_i$ for all $i < I$ and
2. $b_I < b'_I$ if I is even and $b_I > b'_I$ if I is odd.

Using the properties mentioned above, it is not hard to see that $\{n\alpha\} < \{n'\alpha\}$ (in terms of the order on $[0, 1)$) iff $(b_i(n))_{i \geq 0}^O \prec (b_i(n'))_{i \geq 0}^O$ (abbreviating we write $n \prec n'$ if $\{n\alpha\} < \{n'\alpha\}$) and analogously, for $\beta \in \mathbb{T}$, $\{\beta\} < \{n\alpha\}$ iff $(V_n(\beta))_{n \geq 0} \prec n$.

Theorem 1.5.2 *Let $I = [a, b] \subseteq [0, 1)$ be an interval interpreted as interval on \mathbb{T} . Let $\alpha = [0, a_1, a_2 \dots] = \lim_{n \rightarrow \infty} \frac{p_n}{q_n} \in \mathbb{T}^*$. Pick for every $x \in \{a, b, 1 - a, 1 - b\}$ an admissible sequence $(U_i(x))_{i \geq 0}$ such that $x = \sum_{i_0}^{\infty} \{U_i(x)q_i\alpha\}$. Let*

$$\begin{aligned} H_1 &= \{n \in \mathbb{N}_0 : (U_i(a))_{i \geq 0} \prec n \prec (U_i(b))_{i \geq 0}\} \\ H_2 &= \{n \in \mathbb{N}_0 : (U_i(1 - b))_{i \geq 0} \prec n \prec (U_i(1 - a))_{i \geq 0}\}. \end{aligned}$$

Then $H = H_1 \cup (-H_2)$.

Proof: As mentioned above, we know for $n \in \mathbb{N}$ that $\{n\alpha\} \in [x, y)$ iff

$$(U_i(x))_{i \geq 0} \prec n \prec (U_i(y))_{i \geq 0}.$$

Symmetry of the sequence $(n\alpha_n)_{n=1}^{\infty}$ w.r.t. $0 = 1$ finishes the proof. ■

Theorem 1.5.2 can be directly generalized to arbitrary intervals in \mathbb{T} . It already gives a very detailed description of Hartman sets induced by intervals. In fact, this description allows to characterize Hartman sequences which are coding sequences of intervals by an irrational α .

First we will analyze Sturmian sequences corresponding to an α and $I = [0, \alpha)$. Then the following is a well known consequence of Theorem 1.5.2 (cf. [25]). It points out the connection between the structure of a Sturmian word and the continued fraction expansion of the corresponding rotation angle α .

Theorem 1.5.3 Let $\theta > 0$ be irrational. Let $H = (\lfloor n\theta \rfloor)_{n=1}^{\infty}$ be the Beatty sequence corresponding to the Sturmian word induced by $1/\theta$ coding the interval $I = [0, 1/\theta)$. Let $\theta = [1 + t_0; t_1, t_2, \dots] \in \mathbb{R}$. Let $w_{-2} = 1$, $w_{-1} = 0$ and $w_n = w_{n-1}^{d_n} w_{n-2}$. Then $w_n \rightarrow 1_H$ in $\{0, 1\}^{\mathbb{N}}$.

For $n \in \mathbb{N}$, we know that $n\alpha \in I = [0, \alpha)$ iff $n = \sum_{i_0}^{\infty} b_i(n)q_i$ and, according to Theorem 1.5.2,

$$\begin{aligned} (b_i(n))_{i=1}^{\infty} &= (1000000000b_{2k+1}b_{2k+2}b_{2k+3}\dots) \text{ and} \\ & b_{2k+1} > 0 \text{ and } b_{2k+i} \geq 0 \text{ for } i > 1 \text{ or} \\ (b_i(n))_{i=1}^{\infty} &= (0000000000b_{2k}b_{2k+1}b_{2k+2}\dots) \text{ and} \\ & b_{2k} > 0 \text{ and } b_{2k+i} \geq 0 \text{ for } i \geq 1. \end{aligned}$$

Then the following numbers occur in the induced Beatty sequence

$$\left. \begin{array}{l} n \\ n + q_1 \\ \vdots \\ n + k_1q_1 \end{array} \right\} \begin{array}{l} k_1 \text{ such that} \\ b_1(n) + k_1 = X_1 \end{array} \left. \begin{array}{l} n + q_2 \\ n + q_2 + q_1 \\ \vdots \\ n + q_2 + X_1q_1 \\ \vdots \\ n + k_2q_2 \\ n + k_2q_2 + q_1 \\ \vdots \\ n + k_2q_2 + X_1q_1 \end{array} \right\} \begin{array}{l} k_2 \text{ such that} \\ b_2(n) + k_2 = X_2. \end{array}$$

Here $X_1 = \frac{a_2}{a_2-1}$ if $b_0(n) \stackrel{=0}{\neq 0}$, $X_2 = \frac{a_3}{a_3-1}$ if $b_1(n) \stackrel{=0}{\neq 0}$, etc. Note that we started with an arbitrary n . By density of the sequence $(n\alpha)_{n \in \mathbb{N}}$ any segment of a Beatty sequence has the structure described here.

Instead of technical calculations using continued fractions we will now establish a geometrical approach to prove a theorem characterizing interval

coding sequences. Let $\alpha \in (0, 1/2)$, i.e. $\alpha = [0, a_1, a_2, a_3, \dots]$ and $a_1 > 1$. (By symmetry, the case $\alpha \in (1/2, 1)$ can be treated (mutatis mutandis) analogously.)

Let $a \in \mathbb{T}$. Let $I = [a, a + \alpha)$. Let $H = \{n \in \mathbb{N} : n\alpha \in I\}$ be the induced Hartman set. We call $r(n) = \min\{j \in \mathbb{N} : (n + j)\alpha \in I\}$ the return number of α and n . It is easy to see that $r(n) \in \{\lfloor 1/\alpha \rfloor, \lfloor 1/\alpha \rfloor + 1\}$ (in fact, this is a consequence of Theorem 1.5.2). In terms of continued fractions, this means $r(n) \in \{a_1, a_1 + 1\}$.

But $a_1 = q_1$, the denominator of the first convergent. Hence $(n\alpha)_{n \geq 1}$ rotates in I either by the angle $\|q_1\alpha\|$ (if $(n + q_1)\alpha \in I$) or by $\|q_1\alpha + \alpha\|$ (rotation in I means we focus on $n\alpha \in I$ for $n \in H$). According to the assumption $\alpha \in (0, 1/2)$ we know that $q_1\alpha \in (1/2, 1)$, and thus $\|q_1\alpha\| < \|q_0\alpha\| = \alpha$. Let $I = I_1 \cup I_2$, where $I_1 = [a, a + \|q_1\alpha\|)$ and $I_2 = I \setminus I_1$. Let $n\alpha \in I_1$. This is equivalent to $(n + q_1)\alpha \notin I$, i.e. $r(n) = a_1 + 1$. Since

$$\underbrace{n\alpha - a}_{(=\text{distance of } n\alpha \text{ to } a)} + \underbrace{a + \alpha - (n\alpha + q_1\alpha + \alpha)}_{(=\text{distance of } (n + r(n))\alpha \text{ to } a + \alpha)} = q_1\alpha,$$

the rotation by $q_1\alpha$ acts in I like a rotation modulo α . The rotation angle is $\|q_1\alpha\|$. Thus we can interpret the rotation as rotation of $\beta = \|q_1\alpha\|/\alpha$ modulo 1, i.e. on the torus. Let n_1 be the least positive element of H and $s = |n_1\alpha - a|$. Translated to the torus it follows that $\{k\beta\}$ codes the interval $I_\beta = (s/\alpha - \beta, s/\alpha] \bmod 1$. Let $n \in H$. Write 1 whenever $r(n) = q_1 + 1$ and 0 otherwise. Hence that we write 1 iff $n\alpha \in I_1$, $n \in H$, or equivalently whenever $k\beta \in I_\beta$ modulo 1, $k \in \mathbb{Z}$. Then we know already that this procedure yields a Sturmian sequence. In other words, we have verified the following fact:

Lemma 1.5.4 *Let $\mathbf{r} = (r(n))_{n \in \mathbb{Z}} \in \{q, p = q + 1\}^{\mathbb{Z}}$ be the sequence of return numbers of α . Then \mathbf{r} is a Sturmian sequence over the two letter alphabet $\{p, q\}$. \mathbf{r} coincides with the Sturmian sequence generated by $\beta = \|q_1\alpha\|/\alpha$ coding the interval I_β on \mathbb{T} .*

Remark 1.5.5 An iteration of this procedure gives a geometric counterpart to Theorem 1.5.3. In fact, the return number of $q_1\alpha$ in an interval α as described above is a_2 or $a_2 + 1$ (the second partial denominator of α). Thus the total return number (in terms of α in \mathbb{T}) is $a_2 a_1 + 1 = q_2$ or $q_2 + q_1$ the latter one if $q_1\alpha$ lies in an interval of length $q_2\alpha$ (as for the interval I_1 above), etc...

Lemma 1.5.4 is related to questions treated by Vuillon et al. about so-called return words (cf. [28], [41]).

Lemma 1.5.4 shows that one dimensional coding sequences are always closely related to Sturmian sequences. More precisely, if the return numbers $r(n)$ are in $\{q, q+1\}$, there exist possibly up to 2^{q+1} words of length $q+1$. Which words appear depends on the structure of the coded set M . Considering the global structure, i.e. the return numbers, always yields a Sturmian sequence. If \mathbf{a} is a coding sequence of a complicated continuity set M it might be very difficult to find the return numbers of the corresponding α . (We present a method how this can be done in Section 2.3.1.) But if M is only an interval it is easy. We present here an example how to characterize Hartman sets $H = \mathcal{W}_\alpha = \{k \in \mathbb{Z} : k\alpha \in M = \mathbb{T}_+ = [-1/4, 1/4]\}$. Such sets are important for the investigation of so-called quasi convex sets (cf. [7]). Partitions induced by intervals of length $1/2$ were also studied by G. Rote, cf. [34]. Let $\Omega = \{W \subseteq \mathbb{Z} : (\exists \alpha \in \mathbb{T}) W = \mathcal{W}_\alpha\}$. Coding sequences of general intervals can be characterized in a similar way.

Theorem 1.5.6 *Let $W \subseteq \mathbb{Z}$ be a set such that:*

1. *The sequence $w = \mathbf{1}_W$ is a concatenation of 3 basic blocks B , B^+ and B^- . These basic blocks have one of the following structures:*

Case 1: There exists a $k \in \mathbb{N}$ such that

$$B = \underbrace{11\dots1}_k \underbrace{00\dots0}_k, \quad B^+ = \underbrace{11\dots1}_k \underbrace{00\dots0}_{k-1}, \quad B^- = \underbrace{11\dots1}_{k-1} \underbrace{00\dots0}_k.$$

Case 2: There exists a $k \in \mathbb{N}$ such that

$$B = \underbrace{11\dots1}_k \underbrace{00\dots0}_k, \quad B^+ = \underbrace{11\dots1}_{k+1} \underbrace{00\dots0}_k, \quad B^- = \underbrace{11\dots1}_{k-1} \underbrace{00\dots0}_{k+1}.$$

2. *The biinfinite word $\sigma(w) \in \{0, 1\}^{\mathbb{Z}}$ determined by w and the substitution σ defined by $\sigma(B) = 1$ and $\sigma(B^+) = \sigma(B^-) = 0$ is Sturmian.*

Let $\alpha_1 = [0, a_2, a_3, \dots] \in \mathbb{T}$ correspond to the Sturmian word of 2. Let $a_1 = \min\{|B|, |B^+|\}$ according to 1 and $\alpha = [0, a_1, a_2, \dots]$. Then $W \in \Omega$ iff $W = \mathcal{W}_\alpha$.

Proof: Let $\alpha = [0, a_1, a_2, \dots] \in (0, 1/2) \cap \mathbb{T}^*$. Let $I = [-1/4, -1/4 + \alpha)$. Let, as above, $I = I_1 \cup I_2$, $I_1 = [-1/4, -1/4 + \|q_1 \alpha\|)$, $I_2 = I \setminus I_1$. Let, for $n \in C_\alpha(I)$, $r(n) \in \{a_1, a_1 + 1\}$ be the return number of n (recall that $(r(n) = a_1 + 1$ iff $n \in I_1)$). Let $x \in I$ be such that $x + k\alpha = 1/4$ for $k < a_1$. Two cases are possible: (Case 1) If a_1 is odd, then $x \in I_2$, or (Case 2) if a_1 is even, then $x \in I_1$. Both cases correspond to the cases described under condition 1, i.e. $k = (a_1 + 1)/2$ or $k = a_1/2$. Thus, for $W \in \Omega$ one of these two possibilities holds. Moreover, by Lemma 1.5.4, such a $\mathbf{1}_W$ fulfills condition 2. But these two conditions determine α , so the only possibility is $W = \mathcal{W}_\alpha$. ■

Chapter 2

Aspects and applications of Bohr sets

In Chapter 1 (generalized) Bohr sets

$$B(I_{\alpha_1}, \dots, I_{\alpha_d}) = \{k \in \mathbb{Z} : k\alpha_i \in I_{\alpha_i} \text{ for all } i \in \{1, \dots, d\}\},$$

i.e. the base sets of the Bohr topology in \mathbb{Z} , appeared at several positions (the classical Bohr sets which will be used in Section 2.2, induce a base at 0). The aim of this chapter is to analyze the combinatorial structure of such Bohr sets as well as to present further applications of them.

2.1 Complexity and Bohr sets

[40]

In this section we present a new method how to compute the asymptotic growth rate of the complexity function when the coded continuity set is a rectangle in a finite dimensional compactification, i.e. the Hartman sequence is a Bohr set. The ideas introduced here will be extended in the last chapter in order to establish a connection between the complexity of coding sequences and convex geometry.

Let $C = \mathbb{T}^s$ be a finite dimensional compactification with generating element $g = (\alpha_1, \dots, \alpha_s)$ modulo 1, i.e. $\iota : k \mapsto kg = k(\alpha_1, \dots, \alpha_s)$, where the family $\{1, \alpha_1, \dots, \alpha_s\}$ is linearly independent over \mathbb{Z} (such $(kg)_k$ are also

called Kronecker sequences), and M a box in \mathbb{T}^s . To be more precise we use the following notational convention (corresponding to the concept of intervals described before).

$\mathbb{T}^s = (\mathbb{R}/\mathbb{Z})^s = \kappa(\mathbb{R}^s)$ is the image of the additive group \mathbb{R}^s under the mapping $\kappa = \kappa_s : (x_1, \dots, x_s) \mapsto (\{x_1\}, \dots, \{x_s\})$. As before it is useful to think about boxes in \mathbb{T}^s as images of boxes in \mathbb{R}^s etc. To avoid too cumbersome notation we therefore write, for instance, $\prod_{j=1}^s [-\rho_j/2, \rho_j/2)$, $\rho_j \in (0, 1)$ also for the set $M = \kappa_s(\prod_{j=1}^s [-\rho_j/2, \rho_j/2))$. It is natural to call a set $M = \prod_{j=1}^s [m_j, m_j + \rho_j) \subseteq \mathbb{T}^s$ an s -dimensional box in \mathbb{T}^s with side lengths ρ_j , $j = 1, \dots, s$. We are now interested in Hartman sequences $\mathbf{a} = \mathbf{1}_H$, $H = \iota^{-1}(M)$, for this kind of M and call such \mathbf{a} Bohr sequences (corresponding to the Bohr sets).

Let us fix a box M of side lengths ρ_j , $j = 1, \dots, s$, and assume that no ρ_j is in $\alpha_j\mathbb{Z} + \mathbb{Z}$. We are going to determine the asymptotic behaviour of $P_{\mathbf{b}}(n)$ for the Bohr sequence $\mathbf{b} = \mathbf{1}_H$, $H = \iota^{-1}(M)$. To do so, we will estimate the number of words of length n "starting" in a small cube C_0 – we call this number local complexity of C_0 (see equation 2.1 for the precise definition). We obtain bounds for the local complexity by estimating the number of partition cells in C_0 induced by $\partial M - j\alpha$, $j = 0, 1, \dots, N$. For this estimate we use the uniform distribution of the sequence $(ng)_{n=0}^{\infty}$ and the geometry of M . More precisely:

We will use the following notation: For a word $w = a_0 \dots a_{n-1} \in \{0, 1\}^n$ we introduce the set

$$A_w := \{x \in \mathbb{T}^s : (x + ig \in M \Leftrightarrow a_i = 1) \text{ for } i = 0, \dots, n-1\}$$

and write $w = w(x)$ for $x \in A_w$. Note that, provided $A_w \neq \emptyset$, A_w has inner points. Because of the density of the set $\{ng : n \in \mathbb{N}\}$, the continuity of T and the special form of M this implies

$$P_{\mathbf{b}}(n) = |\{w \in \{0, 1\}^n : A_w \neq \emptyset\}|.$$

To compute the number of all nonempty A_w , we first consider a half open cube $C_0 := c_0 + [-\sigma/2, \sigma/2)^s \subseteq \mathbb{T}^s$ with center c_0 and side length $\sigma < \rho_j$ for all $j = 1, \dots, s$. We are going to estimate the local complexity function

$$P(C_0, n) := |W| \quad \text{for} \quad W = W(C_0) := \{w \in \{0, 1\}^n : A_w \cap C_0 \neq \emptyset\}. \quad (2.1)$$

Note that for k cubes C_1, \dots, C_k in \mathbb{T}^s with disjoint closures we have

$$P_{\mathbf{a}}(n) \geq \sum_{j=1}^k P(C_j, n)$$

for sufficiently large n . This holds because, due to the well distribution of the sequence $(ng)_{n=1}^{\infty}$, for any two cubes C_1 and C_2 with disjoint boundary there exists an $n \in \mathbb{N}$ such that $C_1 + ng \subseteq M$ and $C_2 + ng \subseteq (\mathbb{T}^s \setminus M)$.

As above, $A_w \cap C_0 \neq \emptyset$ implies $\mu_C(A_w \cap C_0) > 0$. Hence $P(C_0, n)$ is the number of different words $w = b_i \dots b_{i+n-1}$ of length n in \mathbf{b} with $ig \in C_0$. Define

$$M_0 := \prod_{j=1}^s \left[-\frac{\rho_j}{2} + \frac{\sigma}{2}, \frac{\rho_j}{2} - \frac{\sigma}{2} \right), \quad M_1 := \prod_{j=1}^s \left[-\frac{\rho_j}{2} - \frac{\sigma}{2}, \frac{\rho_j}{2} + \frac{\sigma}{2} \right), \quad \Gamma := M_1 \setminus M_0,$$

and furthermore, for each $j = 1, \dots, s$,

$$\begin{aligned} Q_1^{(j)} &:= \{x = (x_1, \dots, x_s) \in M_1 : x_j < -\frac{\rho_j}{2} + \frac{\sigma}{2} \text{ or } x_j \geq \frac{\rho_j}{2} - \frac{\sigma}{2}\}, \\ Q_0^{(j)} &:= Q_1^{(j)} \setminus \bigcup_{j' \neq j} Q_1^{(j')}. \end{aligned}$$

Observe that the sets $Q_0^{(j)}$ (in contrast to the $Q_1^{(j)}$) are pairwise disjoint. For $w = a_0 \dots a_{n-1}$ in W note that

$$(c_0 + ig \in M_0 \Rightarrow a_i = 1) \text{ and } (c_0 + ig \notin M_1 \Rightarrow a_i = 0).$$

This shows that for $w = a_0 \dots a_{n-1}$ and $w' = a'_0 \dots a'_{n-1}$ in W the letters a_i and a'_i can differ only if $c_0 + ig \in \Gamma$. Since $\Gamma = \bigcup_{j=1}^s Q_1^{(j)}$, we define, for $j = 1, \dots, s$ and $l = 0, 1$,

$$\begin{aligned} I_l^{(j)} &:= \{i \in \{0, \dots, n-1\} : c_0 + ig \in Q_l^{(j)}\}, \\ I_l &:= \bigcup_{j=1}^s I_l^{(j)}. \end{aligned}$$

Due to the special geometric situation (C_0 and M are boxes, see also Figure 2.1), for $x = (x_1, \dots, x_s) \in C_0$, $w = w(x) = (a_i(x))_{0 \leq i < n} \in W$, $j \in \{1, \dots, s\}$, the tuple $(a_i(x))_{i \in I_0^{(j)}}$ depends only on x_j , namely in the

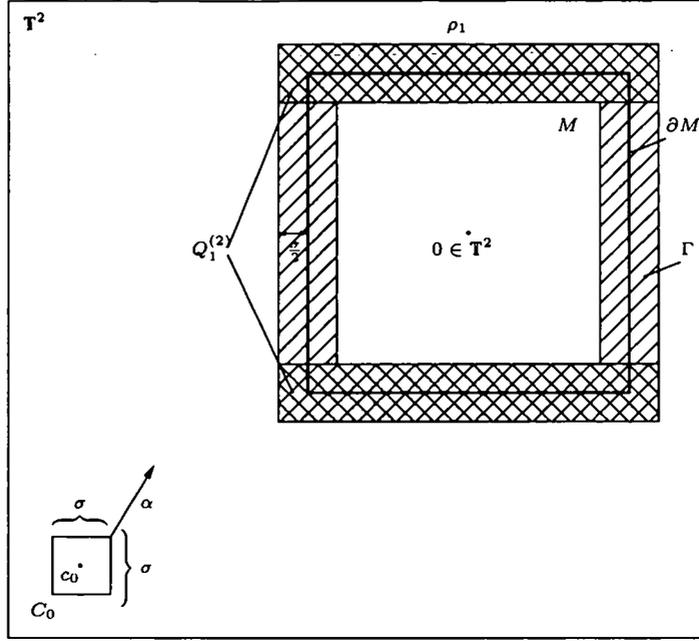

Figure 2.1: ad proof of Theorem 2.1.1

following way. Let $X_j = [y_0, y_0 + \sigma)$ be the interval for the j -th coordinate of points in C_0 . Then for each $i \in I_0^{(j)}$ there is one point y_i (namely either $\rho_j/2 - ig$ or $-\rho_j/2 - ig$) such that y_i splits the interval X_j into two subintervals $X_j^{(0)}$ and $X_j^{(1)}$ such that $a_i(x) = 0$ for $x_j \in X_j^{(0)}$ and $a_i(x) = 1$ for $x_j \in X_j^{(1)}$. Since $\rho_j \notin \alpha_j \mathbb{Z} + \mathbb{Z}$, all $y_i, i \in I_0^{(j)}$, are distinct. As a consequence, the mapping $x_j \mapsto (a_i(x))_{i \in I_0^{(j)}}$ takes at least $|I_0^{(j)}| + 1$ different values, hence

$$A_j = |\{(a_i(x))_{i \in I_0^{(j)}} : x \in C_0\}| \geq |I_0^{(j)}| + 1.$$

Since the sets $I_0^{(j)}, j = 1, \dots, s$, are pairwise disjoint and all coordinates j can be treated independently, we conclude

$$P(C_0, n) = |W| \geq \prod_{j=1}^s (|I_0^{(j)}| + 1).$$

For $\varepsilon > 0$ we know by uniform distribution of the sequence $(ng)_n$ that

$$|I_0^{(j)}| \geq \mu(Q_0^{(j)})n - \varepsilon n$$

for n sufficiently large. Since $\mu(Q_0^{(j)}) = 2 \prod_{j=1, j \neq i}^s (\rho_j - \sigma)\sigma$, $j = 1, \dots, s$, we get

$$|W| \geq n^s \prod_{i=1}^s \left(2 \prod_{j=1, j \neq i}^s ((\rho_j - \sigma)\sigma - \varepsilon) \right)$$

for n sufficiently large. Thus we obtain

$$\liminf_{n \rightarrow \infty} \frac{P(C_0, n)}{n^s} \geq 2^s \prod_{i=1}^s \left(\prod_{j=1, j \neq i}^s (\rho_j - \sigma)\sigma - \varepsilon \right)$$

for all $\varepsilon > 0$ and therefore

$$\liminf_{n \rightarrow \infty} \frac{P(C_0, n)}{n^s} \geq 2^s \prod_{i=1}^s \prod_{j=1, j \neq i}^s (\rho_j - \sigma)\sigma.$$

As a consequence of uniform distribution we know that $d(x, x') > \delta$ implies $w(x) \neq w(x')$ if the words are sufficiently long. Thus $W(C_0)$ and $W(C'_0)$ are disjoint whenever two cubes C_0 and C'_0 are separated by a strictly positive distance δ . Fix now $k \in \mathbb{N}$ and consider the disjoint cubes C_1, \dots, C_{k^s} with centers $c_i = (m_i/k)$, $m_i \in \{0, \dots, k-1\}$ and side length $\sigma = 1/k - \delta$, $0 < \delta < \frac{1}{k}$. We get

$$\liminf_{n \rightarrow \infty} \frac{P_{\mathbf{b}}(n)}{n^s} \geq \sum_{i=1}^{k^s} \liminf_{n \rightarrow \infty} \frac{P(C_i, n)}{n^s} \geq k^s 2^s \left(\frac{1}{k} - \delta\right)^s \prod_{i=1}^s \prod_{j=1, j \neq i}^s (\rho_j - \frac{1}{k} + \delta).$$

Since this holds for all $\delta > 0$ we can consider the limit $\delta \rightarrow 0$ to get

$$\liminf_{n \rightarrow \infty} \frac{P_{\mathbf{b}}(n)}{n^s} \geq k^s 2^s \frac{1}{k^s} \prod_{i=1}^s \prod_{j=1, j \neq i}^s (\rho_j - \frac{1}{k}) = 2^s \prod_{j=1}^s (\rho_j - \frac{1}{k})^{s-1}.$$

For $k \rightarrow \infty$ this finally shows the lower bound

$$\liminf_{n \rightarrow \infty} \frac{P_{\mathbf{b}}(n)}{n^s} \geq 2^s \prod_{j=1}^s \rho_j^{s-1}.$$

To obtain an upper bound for the complexity we consider instead of A_j as defined above the numbers

$$B_j = |\{(a_i(x))_{i \in I_1^{(j)}} : x \in C_0\}| \leq |I_1^{(j)}| + 1.$$

Note that the sets $I_1^{(j)}$, $j = 1, \dots, s$, are (in contrast to the sets $I_0^{(j)}$) not disjoint. This implies that $a_i(x)$ possibly depends on more than one component of x . Comparison with the argument for the lower bound shows that the relevant mapping $x_j \mapsto (a_i(x))_{i \in I_1^{(j)}}$, $x \in C_0$, can only take one additional value, namely the zero word $a_i(x) = 0$ for all $i \in I_1^{(j)}$. Thus arguments similar (in fact even simpler) to those above show that $|B_j| \leq |I_1^{(j)}| + 2$ and finally

$$\limsup_{n \rightarrow \infty} \frac{P_{\mathbf{b}}(n)}{n^s} \leq 2^s \prod_{j=1}^s \rho_j^{s-1}.$$

Since the same argument applies if M is not centered at 0 we have proved:

Theorem 2.1.1 *Consider an ergodic translation $T : x \mapsto x + g$ on \mathbb{T}^s with $g = (\alpha_1, \dots, \alpha_s)$. Assume $\rho_j \in (0, 1) \setminus (\alpha_j \mathbb{Z} + \mathbb{Z})$ for all $j = 1, \dots, s$. For $m_j \in [0, 1)$, $j = 1, \dots, s$, let $M = \prod_{j=1}^s [m_j, m_j + \rho_j)$ denote an s -dimensional box of side lengths ρ_j , and \mathbf{b} the corresponding Bohr sequence. Then the complexity function of \mathbf{b} satisfies*

$$\lim_{n \rightarrow \infty} \frac{P_{\mathbf{b}}(n)}{n^s} = 2^s \prod_{j=1}^s \rho_j^{s-1}.$$

Remark 2.1.2 1. Complexity and volume versus surface: Let $V(M)$ denote the volume of a box M in \mathbb{T}^s and $v_i(M) = \prod_{j=1, j \neq i}^s \rho_j$ the $(s-1)$ -dimensional measures (surfaces) of the facets of M . Then our result can be written in two ways

$$2^s \prod_{j=1}^s \rho_j^{s-1} = 2^s V(M)^{s-1} = 2^s \prod_{i=1}^s v_i(M).$$

Consider first $M' := M_0 \cup M_1$, where M_0 and M_1 are disjoint translates of M . The same argument as in the proof of Theorem 2.1.1 shows that M' induces a Hartman sequence \mathbf{a}' of complexity

$$\lim_{n \rightarrow \infty} \frac{P_{\mathbf{a}'}(n)}{n^s} = 2^s \prod_{i=1}^s (2v_i(M)).$$

Comparison with the value $2^s \prod_{i=1}^s v_i(M)$ for each component M_i , $i = 0, 1$, indicates that the complexity is related to the surface rather than to the volume.

On the other hand we can apply an automorphism A of \mathbb{T}^s (i.e. $A \in \text{SL}(s, \mathbb{Z})$) to $g = (\alpha_1, \dots, \alpha_s)$ and a box M yielding a parallelepiped $A(M)$. A changes neither the corresponding Hartman sequence nor the volume of M while the surface measures may change.

A more systematic investigation of the impact of the geometry of more general sets M on the complexity of the corresponding Hartman sequences will follow in Chapter 3.

2. Dropping linear independence: Those $i \in \{1, 2, \dots, d\}$ for which there exists a $k \in \mathbb{N}$ such that $\rho_i = \{k\alpha_i\}$ are called k -dependent. Since the α_i are irrational each ρ_i is k -dependent for at most one $k \in \mathbb{N}$. Let

$$S_i = \begin{cases} \partial C \cap (C - k\alpha) & \text{if } i \text{ is } k\text{-dependent,} \\ \emptyset & \text{otherwise.} \end{cases}$$

Use the notation introduced in 1. Then an investigation of the proof shows that the formula of Theorem 2.1.1 has to be changed to

$$\lim_{n \rightarrow \infty} \frac{P_{\mathbf{a}'}(n)}{n^s} = \prod_{i=1}^s (2v_i(M) - \lambda^{d-1}(S_i)).$$

3. Complexity determines dimension: Theorem 2.1.1 shows that, knowing $P_{\mathbf{b}}(n)$ and knowing that M is a box (of some unknown dimension s and unknown side lengths ρ_j) it is possible to derive s and, if the involved parameters are linearly independent, $V(M)$.

4. Connection to Section 1.4: Setting $d = 1$, we see that Theorem 2.1.1 indeed extends the results obtained in Section 1.4. Moreover we point out that the main idea to estimate the total complexity via the local complexity (see equation (2.1) for the definition of the local complexity) can be seen as a geometric refinement of what has been done in Section 1.4.2. There we obtained the universal upper bound using an a priori partition of the compact group by open sets of small diameter.

2.2 Characterization of subgroups

[4], [5], [6], [8], [10], [11], [12], [13], [15], [16], [17], [18], [19], [20], [21], [29], [30], [44]

In this section, we focus on the problem to characterize subgroups of a compact group by sequences in the dual group. As we will see, Bohr sets play a central role for this investigation. The presented results are contained in [8].

2.2.1 Introduction

There are several approaches to this topic. First results in our direction are due to Eggeleston and Erdős (cf. [20] and [21]). In [30], the following is proved: If $(q_n)_{n=0}^{\infty}$ is the sequence of denominators of convergents of an irrational number α and if the partial quotients a_0, a_1, a_2, \dots of α are bounded, then $\lim_{n \rightarrow \infty} q_n \beta = 0$ in \mathbb{T} if and only if $\beta = k\alpha$ for a $k \in \mathbb{Z}$. It is easy to see that for any given sequence $(k_n)_{n=1}^{\infty}$ of positive integers, the set $A = \{\alpha : \lim_{n \rightarrow \infty} k_n \alpha = 0\}$ is a subgroup of \mathbb{T} . We say $(k_n)_{n=1}^{\infty}$ characterizes $A \leq \mathbb{T}$. Let again $\alpha = [a_0, a_1, a_2, \dots] = \lim_{n \rightarrow \infty} p_n/q_n$. In [12] it is shown that the increasing sequence consisting of the elements of

$$\{q_i, 2q_i, \dots, a_{i+1}q_i : i \in \mathbb{N}\}$$

characterizes the cyclic subgroup generated by α . Moreover, the authors of [12] developed several techniques to prove the existence of sequences $(k_n)_{n=1}^{\infty}$ of positive integers characterizing countable subgroups H of the circle group $\mathbb{T} = \mathbb{R}/\mathbb{Z}$, i.e., for $\alpha \in \mathbb{T}$,

$$\alpha \in H \iff \lim_{n \rightarrow \infty} k_n \alpha = 0.$$

These methods were extended in [13] to show that if H is generated freely by finitely many elements, a characterization is possible in an even stronger sense: One can choose a characterizing sequence such that $\sum_{n=1}^{\infty} \|k_n \alpha\| < \infty$ for $\alpha \in H$, while $\limsup_{n \rightarrow \infty} \|k_n \alpha\| \geq 1/4$ for $\alpha \in \mathbb{T} \setminus H$. (For $x = r + \mathbb{Z} \in \mathbb{R}/\mathbb{Z}$, $r \in \mathbb{R}$, the norm $\|x\|$ denotes the distance between r and the nearest integer.)

In [44], arbitrary subgroups of \mathbb{T} were characterized by filters on its dual \mathbb{Z} (cf. Section 2.3.1). This approach was used in [6] to extend the results from [13].

A different approach to the characterization of finitely generated dense subgroups of compact abelian groups by sums has recently been introduced in [10] and [11].

Dikranjan et. al. investigated related questions concerning the characterization of subgroups of more general topological abelian groups G (cf. [4], [5], [15], [17]). In the present section we lift the techniques of [6] to this general setting and answer questions stated in [5] and [17]. Results in the context of descriptive set theory were, for instance, obtained by Eliaš in [19].

2.2.2 Further conventions and notation

If not stated otherwise, G is always an infinite compact abelian group. (For finite G most assertions turn out to be trivial.) Elements of G will be denoted by α, β, \dots

Following Chapter 1, we write $H \leq G$ if H is a (not necessarily closed) subgroup of G . If $A \subseteq G$ is any subset, $\langle A \rangle$ denotes the subgroup generated by A . For finite $A = \{\alpha_1, \dots, \alpha_n\} \subseteq G$ and $M \in \mathbb{N}$, we put $\langle A \rangle_M := \{\sum_{i=1}^n k_i \alpha_i : k_i \in \mathbb{Z}, |k_i| \leq M\}$.

Recall that a group compactification of (any topological group) G is a pair (C, ι) where C is a compact group and $\iota : G \rightarrow C$ is a continuous homomorphism with dense image. Relative topologies on G induced by group compactifications are called precompact. The Bohr compactification (bG, ι_B) of G is the compactification of G which is maximal in the sense that for each compactification (C, ι) of G there is a continuous homomorphism $\phi : bG \rightarrow C$ with $\phi \circ \iota_B = \iota$. We take G_d to be G endowed with the discrete topology. As remarked earlier, Duality theory can be applied to construct the Bohr compactification of G by setting $bG := \widehat{(\widehat{G})_d}$ and $\iota_B : \alpha \mapsto x_\alpha$. Accordingly, the Bohr compactification of \widehat{G} is \widehat{G}_d . It is natural to call the precompact topology on G induced by bG the Bohr topology. As we know on the dual group \widehat{G} the Bohr topology can be described by the Bohr sets

$$B_{(\alpha_1, \dots, \alpha_t, \varepsilon)} := \left\{ \chi \in \widehat{G} : \|\chi(\alpha_i)\| \leq \varepsilon \text{ for } i \in \{1, 2, \dots, t\} \right\},$$

where $\alpha_1, \dots, \alpha_t \in G$ and $\varepsilon > 0$. These sets generate the neighborhood filter of 0 in \widehat{G} endowed with the Bohr topology. Furthermore we put $B_{(\alpha_1, \dots, \alpha_t, \varepsilon)}(E) := B_{(\alpha_1, \dots, \alpha_t, \varepsilon)} \cap E$ for $E \subseteq \widehat{G}$. For $\alpha \in G$ and $B \subseteq \widehat{G}$ we write $\|\alpha B\| := \sup\{\|\chi(\alpha)\| : \chi \in B\}$.

2.2.3 Characterizing filters

We modify the filter method from [44] (see also Section 2.3.1) for our purposes. Theorem 2.2.1 essentially states that arbitrary subgroups of compact abelian groups G can be characterized by filters on the (discrete) Pontryagin dual \widehat{G} of G . (Such filters are intended to be the neighborhood filters of 0 w.r.t. precompact group topologies on \widehat{G} .) This filter characterization will again be discussed in Section 2.3.

Recall that a filter \mathcal{F} on a given set S is a system of subsets $F \subseteq S$ such that:

1. $\emptyset \notin \mathcal{F}$.
2. $F \in \mathcal{F}, S \supseteq G \supseteq F \Rightarrow G \in \mathcal{F}$.
3. $F, G \in \mathcal{F} \Rightarrow F \cap G \in \mathcal{F}$.

We will make use of filter limits in the following sense: Let S be any set, let \mathcal{F} be a filter on S , let y be a point in a topological space X and let $f : S \rightarrow X$ be a function. Then we write

$$\mathcal{F} - \lim_s f(s) = y$$

iff for every neighborhood U of y , $\{s \in S : f(s) \in U\} \in \mathcal{F}$.

We remark that filter limits are more general than limits along sequences: For a sequence $(x_n)_{n=1}^{\infty}$ in X , put

$$\mathcal{F}_{(x_n)_{n=1}^{\infty}} = \{A \subseteq X : \exists m \in \mathbb{N} \text{ such that } \{x_n : n \geq m\} \subseteq A\}.$$

Then, $\mathcal{F}_{(x_n)_{n=1}^{\infty}} - \lim_s f(s)$ exists iff $\lim_{n \rightarrow \infty} f(x_n)$ exists and in this case they coincide.

Let $H \leq G$ be a subgroup of the compact abelian group G . Our task is to show that H can be characterized by a filter \mathcal{F}_H on \widehat{G} in the sense that we have $\mathcal{F}_H - \lim_{\chi} \chi(\beta) = 0$ iff $\beta \in H$. It is clear that for all $\alpha \in H$ and all $\varepsilon > 0$, the set $B_{(\alpha, \varepsilon)}$ has to be an element of \mathcal{F}_H to assure convergence for elements of H . By the filter properties of \mathcal{F}_H , the intersection of finitely many such sets will again be an element of \mathcal{F}_H . Thus it would be natural to

define \mathcal{F}_H to be the filter generated by the sets $B_{(\alpha_1, \dots, \alpha_t, \varepsilon)}$ where $\alpha_1, \dots, \alpha_t \in H, \varepsilon > 0$. This definition yields the minimal filter with the required property and corresponds to the precompact group topology on \widehat{G} induced by H . Later, it will be important to us that we may neglect finite sets of characters. Therefore we will also take all cofinite sets to be elements of \mathcal{F}_H . This leads to the following definition:

$$\mathcal{F}_H := \left\{ F \subseteq \widehat{G} : \begin{array}{l} \exists \alpha_1, \dots, \alpha_t \in H, \varepsilon > 0, \Gamma \subseteq \widehat{G}, |\Gamma| < \infty \\ \text{such that } B_{(\alpha_1, \dots, \alpha_t, \varepsilon)}(\widehat{G} \setminus \Gamma) \subseteq F \end{array} \right\}.$$

Theorem 2.2.1 *Let G be an infinite compact abelian group, let H be a subgroup of G and let the filter \mathcal{F}_H be defined as above. Then for all $\beta \in G$*

$$\mathcal{F}_H - \lim_{\chi} \chi(\beta) = 0 \iff \beta \in H.$$

In the course of the proof we will employ the following lemma which will also be useful later on:

Lemma 2.2.2 *Let G be a compact abelian group. Then \widehat{G} is dense in \widehat{G}_d w.r.t. pointwise convergence. Thus, for any countable subset H of G and any $\chi \in \widehat{G}_d$ there exists a sequence $(\chi_n)_{n=1}^{\infty}$ in \widehat{G} such that $\chi_n(\alpha) \rightarrow \chi(\alpha)$ ($n \rightarrow \infty$) for all $\alpha \in H$.*

Proof: As explained in Chapter 1, the compact group \widehat{G}_d is, with the set theoretic inclusion as dense embedding, the Bohr compactification of the discrete group \widehat{G} . This proves the first part. Thus, for $H = \{\alpha_1, \alpha_2, \dots\} \subseteq G$ and every $n \in \mathbb{N}$ there is a $\chi_n \in \widehat{G}$ with $\|\chi_n(\alpha_i) - \chi(\alpha_i)\| < \frac{1}{n}$ for all $i \in \{1, 2, \dots, n\}$. It follows that $\chi_n \rightarrow \chi$ pointwise on H . ■

Proof of Theorem 2.2.1: The definition of the filter \mathcal{F}_H guarantees that $\mathcal{F} - \lim_{\chi} \|\chi(\beta)\| = 0$ for all $\beta \in H$. For the converse we prove that, given $\beta \notin H$, for all $\alpha_1, \dots, \alpha_t \in H$ and every $\varepsilon > 0$ there exist infinitely many characters $\chi \in B_{(\alpha_1, \dots, \alpha_t, \varepsilon)}$ with $\|\chi(\beta)\| \geq 1/4$ which implies that $\{\chi \in \widehat{G} : \|\chi(\beta)\| < 1/4\} \notin \mathcal{F}$. First we see that there exists at least one such character: Consider the Bohr compactification \widehat{G}_d of \widehat{G} . \widehat{G}_d separates subgroups and points of G . Hence there exists some $\phi \in \widehat{G}_d$ such that

$$\phi(\alpha) = 0 \text{ for all } \alpha \in \langle \alpha_1, \dots, \alpha_t \rangle \quad \text{and} \quad c = \phi(\beta) \neq 0,$$

w.l.o.g. $\|\phi(\beta)\| \geq 1/3$ (otherwise take an appropriate multiple $2\phi, 3\phi, \dots$). By Lemma 2.2.2 ϕ can be approximated arbitrarily well on finitely many points by a character. Thus we find some $\chi \in \widehat{G}$ such that $\|\chi(\alpha_i)\| \leq \varepsilon, 1 \leq i \leq t, \|\chi(\beta)\| > 1/4$.

Next we prove that for $\varepsilon > 0$ each $B_{(\alpha_1, \dots, \alpha_t, \varepsilon)}$ contains infinitely many χ with $\|\chi(\beta)\| \geq 1/4$. Let $U := \{(\chi(\alpha_1), \dots, \chi(\alpha_t), \chi(\beta)) : \chi \in \widehat{G}\} \leq \mathbb{T}^{t+1}$. We distinguish two cases:

1. U is finite, say $U = \{u_1, \dots, u_k\}$. There is some i , say $i = 1$, with $u_1 := (0, \dots, 0, c)$. Then the sets

$$\Upsilon_i := \left\{ \chi \in \widehat{G} : (\chi(\alpha_1), \dots, \chi(\alpha_t), \chi(\beta)) = u_i \right\}, \quad i = 1, \dots, k,$$

and particularly Υ_1 are infinite, or

2. U is an infinite subgroup of \mathbb{T}^{t+1} . But then each point of U is an accumulation point.

In both cases we find infinitely many χ with the required property. ■

2.2.4 Characterizing countable subgroups

We turn to Problem 5.3 from [17]: For which compact abelian G can every countable subgroup H be characterized by a sequence of characters?

For $A \subseteq \widehat{G}$ we write $\lim_{\chi \in A} \chi(\beta) = 0$ iff $\{\chi \in A : \chi(\beta) \geq \varepsilon\}$ is finite for all $\varepsilon > 0$. (I.e. instead of the characterizing sequence $(\chi_n)_{n=1}^{\infty}$ we consider the characterizing set $A = \{\chi_n : n \in \mathbb{N}\}$.)

Theorem 2.2.3 *Let G be an infinite compact abelian group and let $H \leq G$ be a countable subgroup. Then the following statements are equivalent:*

(i) G is metrizable.

(ii) There exists a countable set $A \subseteq \widehat{G}$, such that

$$\beta \in H \iff \lim_{\chi \in A} \chi(\beta) = 0.$$

Remark. The proof of Theorem 2.2.3 actually shows that (if G is metrizable) for every $\sigma < 1/3$ the characterizing set A can be chosen in such a way that $\beta \notin H$ implies $\limsup_{\chi \in A} \|\chi(\beta)\| \geq \sigma$. Using a diagonalization argument it is not difficult to achieve $\limsup_{\chi \in A} \|\chi(\beta)\| \geq 1/3$ and it is easy to

see that this is best possible.

The proof of (i) \implies (ii) employs several lemmas which we formulate now and verify at the end of this section. According to our assumptions, in these lemmas G is an infinite compact abelian metrizable group.

Lemma 2.2.4 *Let $\tau \in \mathbb{T}$ and $n \in \mathbb{N}$. Assume that $\|i\tau\| \leq \sigma < 1/3$ for all $i \in \{1, 2, \dots, n\}$. Then $\|\tau\| \leq \sigma/n$.*

Lemma 2.2.5 *Assume that $\gamma_1, \dots, \gamma_d \in G$ freely generate a subgroup of G . For arbitrary nonempty open sets I_1, \dots, I_d in \mathbb{T} there exists $\chi \in \widehat{G}$ such that $\chi(\gamma_i) \in I_i$ for all $i \in \{1, 2, \dots, d\}$.*

Lemma 2.2.6 *Let $\alpha_1, \dots, \alpha_t \in G$, $\varepsilon > 0$ and $\sigma < 1/3$.*

1. *For all finite $\Gamma \subseteq \widehat{G}$ and all $\beta \in G$*

$$\|\beta B_{(\alpha_1, \dots, \alpha_t, \varepsilon)}(\widehat{G} \setminus \Gamma)\| \leq \sigma \implies \beta \in \langle \alpha_1, \dots, \alpha_t \rangle.$$

2. *Moreover there exists $M \in \mathbb{N}$ such that for all finite $\Gamma \subseteq \widehat{G}$ and all $\beta \in G$*

$$\|\beta B_{(\alpha_1, \dots, \alpha_t, \varepsilon)}(\widehat{G} \setminus \Gamma)\| \leq \sigma \implies \beta \in \langle \alpha_1, \dots, \alpha_t \rangle_M.$$

3. *If $V \supseteq \langle \alpha_1, \dots, \alpha_t \rangle_M$ is an open subset of G then for all finite $\Gamma \subseteq \widehat{G}$ there exists a finite set $E \subseteq \widehat{G} \setminus \Gamma$ such that for $\beta \in G$*

$$\|\beta B_{(\alpha_1, \dots, \alpha_t, \varepsilon)}(E)\| \leq \sigma \implies \beta \in V.$$

Lemma 2.2.7 *Let $R_1 \subseteq R_2 \subseteq \dots$ be finite subsets of G . There exists a sequence of open sets $V_n \subseteq G$, $n \in \mathbb{N}$ such that*

1. $V_n \supseteq R_n$.

$$2. \liminf_{n \rightarrow \infty} V_n = \bigcup_{m=1}^{\infty} \bigcap_{n=m}^{\infty} V_n = \bigcup_{n=1}^{\infty} R_n.$$

Proof of Theorem 2.2.3:

(i) \implies (ii): We will first construct the set $A \subseteq \widehat{G}$ and then prove that $\beta \in H$ iff $\lim_{\chi \in A} \chi(\beta) = 0$.

Let $H =: \{\alpha_t : t \in \mathbb{N}\}$ and pick $\varepsilon = \sigma \in (0, 1/3)$. Using Lemma 2.2.6,2 we can choose a sequence $(M_t)_{t=1}^\infty$ such that for every finite $\Gamma \subseteq \widehat{G}$ and all $\beta \in G$

$$\|\beta B_{(\alpha_1, \dots, \alpha_t, \varepsilon)}(\widehat{G} \setminus \Gamma)\| \leq \varepsilon \implies \beta \in \langle \alpha_1, \dots, \alpha_t \rangle_{M_t}.$$

Next put, for $t \in \mathbb{N}$, $R_t := \langle \alpha_1, \dots, \alpha_t \rangle_{M_t}$ and define $V_t \supseteq R_t$ according to Lemma 2.2.7 such that $\liminf_{t \rightarrow \infty} V_t = H$.

Using Lemma 2.2.6,3 we choose a finite set $E_1 \subseteq \widehat{G}$ such that

$$\|\beta B_{(\alpha_1, \varepsilon)}(E_1)\| \leq \varepsilon$$

implies $\beta \in V_1$. By employing Lemma 2.2.6,3 again, we find $E_2 \subseteq \widehat{G} \setminus E_1$ such that $\|\beta B_{(\alpha_1, \alpha_2, \varepsilon)}(E_2)\| \leq \varepsilon$ implies $\beta \in V_2$. Continuing in this fashion we arrive at a sequence $(E_t)_{t=1}^\infty$ of disjoint subsets of \widehat{G} such that for each $t \in \mathbb{N}$

$$\|\beta B_{(\alpha_1, \dots, \alpha_t, \varepsilon)}(E_t)\| \leq \varepsilon \implies \beta \in V_t.$$

Finally we put $A := \bigcup_{t=1}^\infty B_{(\alpha_1, \dots, \alpha_t, \varepsilon)}(E_t)$.

Assume that $\beta \in H$. To prove $\lim_{\chi \in A} \|\chi(\beta)\| = 0$ note that, for arbitrary $n \in \mathbb{N}$, there exists $T = T(n) \in \mathbb{N}$ such that $i\beta \in \{\alpha_t : t \leq T\}$ for all $i \in \{1, 2, \dots, n\}$. Thus whenever $\chi \in B_{(\alpha_1, \dots, \alpha_t, \varepsilon)}(E_t)$ for some $t \geq T$ we have $\|i\chi(\beta)\| \leq \varepsilon$ for all $1 \leq i \leq n$. By Lemma 2.2.4 this yields $\|\chi(\beta)\| \leq \varepsilon/n$. Since n was arbitrary we get $\lim_{\chi \in A} \|\chi(\beta)\| = 0$.

Conversely assume that $\limsup_{\chi \in A} \|\chi(\beta)\| < \varepsilon$ for some $\beta \in G$. Then for all but finitely many $t \in \mathbb{N}$ we have $\|\beta B_{(\alpha_1, \dots, \alpha_t, \varepsilon)}(E_t)\| \leq \varepsilon$. Thus there exists $t_0 \in \mathbb{N}$ such that $\beta \in V_t$ for all $t \geq t_0$ which yields $\beta \in H$ by the choice of the sequence $(V_t)_{t=1}^\infty$.

(ii) \implies (i): Let $H \leq G$ be an arbitrary countable subgroup characterized by the countable set $A \subseteq \widehat{G}$. Define $\Lambda := \langle A \rangle$ and

$$\Lambda^0 := \{g \in G : \chi(g) = 0 \text{ for all } \chi \in \Lambda\},$$

the annihilator of Λ . Clearly $\Lambda^0 \leq H$, thus $|\Lambda^0| \leq \aleph_0$. Since $\widehat{\Lambda} \cong G/\Lambda^0$ we have $w(G/\Lambda^0) = w(\widehat{\Lambda}) = |\Lambda| = \aleph_0$, where w denotes the topological weight, i.e. the least cardinal number of an open basis (see 1). Hence G/Λ^0 and Λ^0 have at most countable weight and therefore also G , implying that G is metrizable. ■

Let G be a compact abelian group. In [17] subgroups characterized by a sequence $(\chi_n)_{n=1}^\infty$ in \widehat{G} are denoted by

$$s_{(\chi_n)_{n=1}^\infty}(G) := \left\{ \alpha \in G : \lim_{n \rightarrow \infty} \chi_n(\alpha) = 0 \right\}.$$

Furthermore such subgroups are called basic \mathfrak{g} -closed subgroups. According to Theorem 2.2.3 every countable subgroup of G is basic \mathfrak{g} -closed iff G is metrizable.

A group $H \leq G$ is called \mathfrak{g} -closed if it is representable as the intersection of basic \mathfrak{g} -closed subgroups. The next theorem deals with \mathfrak{g} -closed subgroups and solves Problem 5.1 from [17].

Theorem 2.2.8 *Every countable subgroup H of a compact abelian group G is \mathfrak{g} -closed.*

Proof: For arbitrary $\beta \in G \setminus H$ there is a $\chi \in \widehat{G}_d$ with $\chi(\alpha) = 0$ for all $\alpha \in H$ and $\|\chi(\beta)\| \geq \frac{1}{3}$. Thus Lemma 2.2.2 immediately yields a sequence of $(\chi_n^\beta)_{n=1}^\infty$ in \widehat{G} characterizing a subgroup

$$H_\beta := s_{(\chi_n^\beta)_{n=1}^\infty}(G) = \left\{ \alpha \in G : \lim_{n \rightarrow \infty} \chi_n^\beta(\alpha) = 0 \right\} \leq G$$

with $H \leq H_\beta$ and $\beta \notin H_\beta$. Thus $H = \bigcap_{\beta \in G \setminus H} H_\beta$. ■

Proofs of Lemmas 2.2.4 to 2.2.7 :

We assume the group G to be compact abelian and metrizable. Lemma 2.2.4 is elementary, so we skip the proof.

Proof of Lemma 2.2.5: Assume that

$$A := \widehat{G}\langle \gamma_1, \dots, \gamma_d \rangle = \{ \chi(\alpha) : \chi \in \widehat{G}, \alpha \in \langle \gamma_1, \dots, \gamma_d \rangle \}$$

is not dense in \mathbb{T}^d , i.e. $\overline{A} \subsetneq \mathbb{T}^d$. There is a nontrivial character of \mathbb{T}^d vanishing on \overline{A} , i.e. a nonzero vector $h = (h_1, \dots, h_d) \in \mathbb{Z}^d$ such that $\sum_{i=1}^d h_i x_i = 0$ holds for all $x = (x_1, \dots, x_d) \in \overline{A}$. Fix an arbitrary $\chi \in \widehat{G}$ and put $x_i = \chi(\gamma_i)$. Then

$$0 = \sum_{i=1}^d h_i \chi(\gamma_i) = \chi \left(\sum_{i=1}^d h_i \gamma_i \right).$$

Since this holds for all $\chi \in \widehat{G}$ we have $\sum_{i=1}^d h_i \gamma_i = 0$, contradicting the independence of the free generators γ_i , $1 \leq i \leq d$. \blacksquare

Proof of Lemma 2.2.6: Let $B_0 := B_{(\alpha_1, \dots, \alpha_t, \varepsilon)}(\widehat{G} \setminus \Gamma)$.

1. Let $\mathcal{F} = \mathcal{F}_{(\alpha_1, \dots, \alpha_t)}$ be the filter of Theorem 2.2.1 characterizing $\langle \alpha_1, \dots, \alpha_t \rangle$ and let $\delta > 0$ be arbitrary. Under the assumption $\|\beta B_0\| \leq \sigma < 1/3$ we have to show that

$$F_\delta := \left\{ \chi \in \widehat{G} \setminus \Gamma : \|\chi(\beta)\| \leq \delta \right\} \in \mathcal{F}.$$

Choose $m \in \mathbb{N}$ such that $\delta \geq \sigma/m$ and let $B_1 := B_{(\alpha_1, \dots, \alpha_t, \varepsilon/m)}(\widehat{G} \setminus \Gamma)$. By definition of \mathcal{F} we have $B_1 \in \mathcal{F}$. For all $\chi \in B_1$, $i \in \{1, 2, \dots, m\}$, we have $i\chi \in B_0$. Thus $\|i\chi(\beta)\| \leq \sigma$ for all $i \in \{1, 2, \dots, m\}$ and Lemma 2.2.4 yields $\|\chi(\beta)\| \leq \sigma/m < \delta$. Thus $B_1 \subseteq F_\delta$ and hence $F_\delta \in \mathcal{F}$.

2. Assume that $H := \langle \alpha_1, \dots, \alpha_t \rangle$ is infinite (otherwise the assertion follows immediately). Since H is a finitely generated abelian group there exists a decomposition $H = T \oplus F$ where F is freely generated by $\gamma_1, \dots, \gamma_d$ and $T = \langle \nu_1, \dots, \nu_l \rangle = \bigoplus_{i=1}^l \langle \nu_i \rangle$ is the torsion subgroup of H . Hence $\langle \nu_i \rangle \cong \mathbb{Z}/e_i\mathbb{Z}$ for some $e_i \in \mathbb{N}$ and

$$\langle \alpha_1, \dots, \alpha_t \rangle = \langle \gamma_1, \dots, \gamma_d \rangle \oplus \langle \nu_1, \dots, \nu_l \rangle \cong \mathbb{Z}^d \oplus \bigoplus_{i=1}^l \mathbb{Z}/e_i\mathbb{Z}.$$

Let $\delta > 0$ be such that $\|\chi(\gamma_i)\| \leq \delta$ for $i \in \{1, 2, \dots, d\}$ and $\chi(\nu_j) = 0$ for $j \in \{1, 2, \dots, l\}$ implies $\|\chi(\alpha_k)\| \leq \varepsilon$ for $k \in \{1, 2, \dots, t\}$.

Pick now any $\beta \in G$ with $\|\beta B_0\| \leq \sigma < 1/3$. By 1. above we have $\beta \in H$, thus $\beta = \sum_{i=1}^d r_i \gamma_i + \sum_{j=1}^l s_j \nu_j$ for some $r_i \in \mathbb{Z}$, $s_j \in \{0, 1, \dots, e_j - 1\}$, $i \in \{1, 2, \dots, d\}$, $j \in \{1, 2, \dots, l\}$. Let $e := \prod_{j=1}^l e_j$. By Lemma 2.2.5 there exist infinitely many $\chi \in e\widehat{G} := \{e\chi' : \chi' \in \widehat{G}\}$ such that

$$\text{sign}(r_i)\chi(\gamma_i) \in \left[\frac{1}{3 \sum_{j=1}^d |r_j|}, \frac{2}{3 \sum_{j=1}^d |r_j|} \right] + \mathbb{Z}$$

holds for $i \in \{1, 2, \dots, d\}$. Therefore we have

$$r_i \chi(\gamma_i) \in \left[\frac{|r_i|}{3 \sum_{j=1}^d |r_j|}, \frac{2|r_i|}{3 \sum_{j=1}^d |r_j|} \right] + \mathbb{Z}$$

for all $i \in \{1, 2, \dots, d\}$. Summing up and using that $\chi(\nu_j) = 0$ for $j \in \{1, 2, \dots, l\}$ this leads to

$$\chi(\beta) = \sum_{i=1}^d r_i \chi(\gamma_i) \in \left[\frac{1}{3}, \frac{2}{3} \right] + \mathbb{Z}.$$

Thus $\chi \notin B_{(\alpha_1, \dots, \alpha_t, \varepsilon)}$ and hence there is $j \in \{1, \dots, t\}$ with $\|\chi(\alpha_j)\| > \varepsilon$ and therefore $\delta < \frac{2}{3 \sum_{j=1}^d |r_j|}$. Equivalently $\sum_{i=1}^d |r_i| < \frac{2}{3\delta}$. So there are only finitely many choices for β and we may put an universal bound M on the coefficients in the linear combination $\beta = \sum_{i=1}^r k_i \alpha_i$.

3. Clearly, the set

$$I := \{\beta \in G : \|\beta B_0\| \leq \sigma\} = \bigcap_{\chi \in B_0} \{\gamma \in G : \|\chi(\gamma)\| \leq \sigma\}$$

is closed and by 2. we have $I \subseteq \langle \alpha_1, \dots, \alpha_t \rangle_M \subseteq V$. Thus $I \cap V^c = \emptyset$. By compactness of G there exists a finite set $E \subseteq B_0$ such that

$$\bigcap_{\chi \in E} \{\gamma \in G : \|\chi(\gamma)\| \leq \sigma\} \cap V^c = \emptyset.$$

This E is as required. ■

Proof of Lemma 2.2.7: Let ρ be a metric on G compatible with its topology. Since the sets $R_1 \subseteq R_2 \subseteq \dots \subseteq G$ are finite there is a sequence $(d_n)_{n=1}^\infty$ of positive reals decreasing to 0 such that

$$\begin{aligned} 2d_n &< \min\{\rho(\alpha, \alpha') : \alpha, \alpha' \in R_n, \alpha \neq \alpha'\} \\ d_n + d_{n+1} &< \min\{\rho(\alpha, \alpha') : \alpha \in R_n, \alpha' \in R_{n+1} \setminus R_n\}. \end{aligned}$$

Define

$$V_n := \{\beta \in G : \exists \alpha \in R_n \text{ with } \rho(\beta, \alpha) < d_n\}.$$

By monotonicity of the sets R_n , $\beta \in \bigcup_{n=1}^\infty R_n$ implies $\beta \in \bigcup_{m=1}^\infty \bigcap_{n=m}^\infty V_n$. Conversely, assume $\beta \in \bigcup_{m=1}^\infty \bigcap_{n=m}^\infty V_n$ or, equivalently, that there exists an m with $\beta \in V_n$ for all $n \geq m$. According to the definition of the sets V_n there exists a unique $\alpha_n \in R_n$ such that $\rho(\alpha_n, \beta) < d_n$ for $n \geq m$. Moreover the choice of the d_n guarantees that $\alpha_m = \alpha_{m+1} = \dots$ and so $\rho(\beta, \alpha_m) = \rho(\beta, \alpha_n) \leq d_n \rightarrow 0$. Hence $\beta = \alpha_m \in R_m \subseteq \bigcup_{n=1}^\infty R_n$. ■

2.2.5 Thick and thin characterizing sequences

Question 5.2 from [5] asks: Does every countable subgroup H of \mathbb{T} admit a characterizing sequence $(k_n)_{n=1}^{\infty}$ with bounded quotients, i.e. $r_n = \frac{k_{n+1}}{k_n} \leq C$ for all $n \in \mathbb{N}$ and some $C \in \mathbb{R}$?

We answer this question affirmatively by proving a stronger result. Which type of statement can be expected? Assume that $\alpha \in H$ is irrational. Then, by uniform distribution of the sequence $(n\alpha)_{n=1}^{\infty}$, the set of all $k \in \mathbb{N}$ with $\|k\alpha\| < \varepsilon$ has density 2ε . Thus (with the exception of trivial cases) characterizing sequences have zero density. Furthermore the length of their gaps tends to infinity. In particular the thickest characterizing sequences we can expect might have a density which converges to zero very slowly in some sense. This is the content of the following result.

Theorem 2.2.9 *Let $H \leq \mathbb{T}$ be a countable subgroup and let $(\varepsilon_j)_{j=1}^{\infty}$ be a sequence with $0 \leq \varepsilon_j \leq 1$ that converges to 0. Let \mathbb{N} be partitioned into nonempty intervals $I_j = \{i_j, i_j + 1, \dots, i_{j+1} - 1\}$ with $i_0 = 0$ and $\lim_{j \rightarrow \infty} (i_{j+1} - i_j) = \infty$. Then there exists a sequence $(k_n)_{n=1}^{\infty}$ of nonnegative integers characterizing H such that*

$$\frac{|\{n : k_n \in I_j\}|}{|I_j|} \geq \varepsilon_j \quad \text{for all } j.$$

Proof: Let, according to Theorem 2.2.3 (or to [12]), $c_1 < c_2 < \dots \in \mathbb{N}$ be any sequence characterizing H . We are going to construct a sequence $d_1 < d_2 < \dots \in \mathbb{N}$ containing at least $\varepsilon_j |I_j|$ elements in each I_j such that $\|d_n \alpha\| \rightarrow 0$ for all $\alpha \in H$. Then $A = \{k_1 < k_2 < \dots\} = \{d_n : n \in \mathbb{N}\} \cup \{c_n : n \in \mathbb{N}\}$ clearly has the desired properties.

Let $H = \{\alpha_t : t \in \mathbb{N}\}$, put $I_j^+(0) := I_j$ and

$$I_j^+(t) := \{k \in I_j : \|k\alpha_i\| < 1/t \text{ for all } i \in \{1, 2, \dots, t\}\}$$

for $t \geq 1$. For each $j \in \mathbb{N}$ let t_j be the maximal $t \in \{0, 1, \dots, j\}$ such that $|I_j^+(t)| \geq \varepsilon_j |I_j|$ and put

$$\{d_1 < d_2 < \dots\} = \bigcup_{j=0}^{\infty} I_j^+(t_j).$$

It suffices to show that $t_j \rightarrow \infty$ for $j \rightarrow \infty$ or, equivalently, that for each $t_0 \in \mathbb{N}$ there exists j_0 such that for all $j \geq j_0$

$$\left| \{d \in I_j : \|d\alpha_i\| < 1/t_0 \text{ for all } i = 1, \dots, t_0\} \right| \geq \varepsilon_j |I_j|.$$

Since $\varepsilon_j \rightarrow 0$ for $j \rightarrow \infty$ this is an immediate consequence of the well distribution (in monothetic groups, cf. Theorem 1.1.25) of the sequence $(ng)_{n=1}^\infty$ in the closed subgroup $G \leq \mathbb{T}^{t_0}$ generated by $g = (\alpha_1, \dots, \alpha_{t_0}) \in \mathbb{T}^{t_0}$: The open subset $O \subseteq G$ of all $(\beta_1, \dots, \beta_{t_0})$ with $\|\beta_i\| < 1/t_0$ has positive Haar measure $\mu(O)$ and the set of all $k \in \mathbb{Z}$ with $kg \in O$ has uniform density $\mu(O) > 0$. ■

Theorem 2.2.9 indeed answers the question about quotients: Take, for instance, $i_j = j^2$ and choose a sequence of strictly positive ε_j . Then the quotients $r_n = \frac{k_{n+1}}{k_n}$ tend to 1. This example can be modified in many ways.

It has been proved in [5] that $r_n \rightarrow \infty$ implies that the corresponding characterized group H is uncountable. Thus, for a given countable H , characterizing sequences cannot be arbitrarily sparse in this sense. Nevertheless we have:

Theorem 2.2.10 *Let H be a countable subgroup of \mathbb{T} and let $m_1 < m_2 < \dots$ be an increasing sequence of positive integers. Then there is a characterizing sequence $k_1 < k_2 < \dots$ for H with $m_n < k_n$ for all $n \in \mathbb{N}$.*

Proof: Let $(c_n)_{n=1}^\infty$ be any characterizing sequence of H . Put $k_{2n} := c_{j_n}$ and $k_{2n+1} := c_{j_n} + c_n$ where j_n is large enough in the sense that $k_{2n} > m_{2n}$ and $k_{2n+1} > m_{2n+1}$. Clearly $\alpha \in H$ implies $k_n \alpha \rightarrow 0$. On the other hand, if $\beta \in \mathbb{T}$ and $k_n \beta \rightarrow 0$ then also $(k_{2n+1} - k_{2n})\beta = c_n \beta \rightarrow 0$. $(c_n)_{n=1}^\infty$ characterizes H , therefore $\beta \in H$. ■

Theorem 2.2.10 implies that for any countable $H \leq \mathbb{T}$ there are sequences $(k_n)_{n=1}^\infty$ characterizing H with $\limsup_{n \rightarrow \infty} \frac{k_{n+1}}{k_n} = \infty$: In Theorem 2.2.10 put $m_n = n^n$ and let $k_1 < k_2 < \dots$ be a characterizing sequence of H such that $m_n \leq k_n$ for all $n \in \mathbb{N}$. Then

$$\sup_{n \in \mathbb{N}} \frac{k_{n+1}}{k_n} \geq \sup_{n \in \mathbb{N}} \sqrt[n]{\prod_{i=1}^n \frac{k_{i+1}}{k_i}} \geq \sup_{n \in \mathbb{N}} \sqrt[n]{\frac{k_n}{k_1}} \geq \sup_{n \in \mathbb{N}} \sqrt[n]{\frac{n^n}{k_1}} = \infty.$$

Note that this is also contained in [5], Remark 3.5. In [12] this fact is shown in a similar way for the special case that H is a cyclic group.

For more sophisticated methods to generate sparse characterizing sequences we refer to [6] and [13]: E.g. for a countable subgroup $H \leq \mathbb{T}$ one can construct a characterizing sequence $(k_n)_{n=1}^\infty$ such that for all $r > 0$

and $\alpha \in H$, $\sum_{n=1}^{\infty} \|k_n \alpha\|^r < \infty$.

The idea of the proof of Theorem 2.2.10 has further remarkable extensions. We will analyze them more detailed in the next section.

2.2.6 Groups as sets of convergence

In this Section 2.2.6 we introduce a refined characterization of subgroups of a compact metrizable group G by sequences: For a sequence $(\chi_n)_{n=1}^{\infty}$ in \widehat{G} we consider the set H of all $\alpha \in G$ for which $(\chi_n(\alpha))_{n=1}^{\infty}$ converges (not necessarily to $0 \in \mathbb{T}$). H is easily seen to be a subgroup of G and the pointwise limit is a (not necessarily continuous) homomorphism $f : H \rightarrow \mathbb{T}$. The following Theorem 2.2.11 gives a complete description of the situation: Given any subgroup H of a metrizable compact abelian group G and any homomorphism $f : H \rightarrow \mathbb{T}$ there is a sequence $(\chi_n)_{n=1}^{\infty}$ in \widehat{G} such that $\chi_n \rightarrow f$ pointwise on H . If H is countable then one can even achieve that H is exactly the set of convergence. If G is a compact (not necessarily metrizable) group and H is an arbitrary (not necessarily countable) subgroup of G , this result is still valid when the convergence of sequences is replaced by the more general convergence of filters. By considering the trivial homomorphism $f \equiv 0$ we see that Theorem 2.2.11 nicely extends Theorem 2.2.3. Furthermore this result allows to construct counterexamples to Question 5.4 from [5] (see below).

Theorem 2.2.11 *Let G be a compact abelian group.*

1. *Let \mathcal{F} be a filter on \widehat{G} . Then the set H of all $\alpha \in G$ for which $\mathcal{F} - \lim_{\chi} \chi(\alpha)$ exists is a subgroup of G . The mapping $f : H \rightarrow \mathbb{T}$, $\alpha \mapsto \mathcal{F} - \lim_{\chi} \chi(\alpha)$ is a group homomorphism.*

In particular if $(\chi_n)_{n=1}^{\infty}$ is a sequence in \widehat{G} , the set H of all $\alpha \in G$ for which $\lim_{n \rightarrow \infty} \chi_n(\alpha)$ exists is a subgroup and the mapping $f : H \rightarrow \mathbb{T}$, $\alpha \mapsto \lim_{n \rightarrow \infty} \chi_n(\alpha)$ is a group homomorphism.

2. *Let conversely H be a subgroup of G and let $f : H \rightarrow \mathbb{T}$ be a homomorphism. Then there exists a filter \mathcal{F} on \widehat{G} such that $\mathcal{F} - \lim_{\chi} \chi(\alpha) = f(\alpha)$ for all $\alpha \in H$ and $\mathcal{F} - \lim_{\chi} \chi(\beta)$ does not exist whenever $\beta \notin H$.*
3. *If furthermore $H \leq G$ is countable then there exists a sequence $(\chi_n)_{n=1}^{\infty}$ in \widehat{G} such that*

$$\chi_n(\alpha) \rightarrow f(\alpha) \quad \text{for all } \alpha \in H.$$

4. If G is metrizable and H is countable then there exists a sequence $(\chi'_n)_{n=1}^\infty$ in \widehat{G} such that

$$\chi'_n(\alpha) \rightarrow f(\alpha) \quad \text{for all } \alpha \in H$$

and $(\chi'_n(\beta))_{n=1}^\infty$ does not converge if $\beta \notin H$.

Proof: 1: Assume $a, b \in H$ and consider $c = a - b$. Let $U \in \mathcal{U}(f(a) - f(b))$. We must show that there exists a set $F \in \mathcal{F}$ such that $\chi(c) \in U$ holds for all $\chi \in F$. According to U there exist $U_a \in \mathcal{U}(a)$ and $U_b \in \mathcal{U}(b)$ such that $U_a - U_b \subseteq U$. $a, b \in H$ implies that there exist sets F_a and $F_b \in \mathcal{F}$ such that $\chi(a) \in U_a$ for all $\chi \in F_a$ and $\chi(b) \in U_b$ for all $\chi \in F_b$. Let $F := F_a \cap F_b$ and $\chi \in F$. Then $\chi(c) = \chi(a - b) = \chi(a) - \chi(b) \in U_a - U_b \subseteq U$. Since U was arbitrary we get $\mathcal{F} - \lim_\chi \chi(c) = f(a) - f(b)$. Thus $c \in H$ and f is a homomorphism.

2. For $\alpha_1, \dots, \alpha_t \in H$ and $\varepsilon > 0$ put

$$F(\alpha_1, \dots, \alpha_t, \varepsilon) := \left\{ \chi \in \widehat{G} : \|\chi(\alpha_i) - f(\alpha_i)\| \leq \varepsilon \text{ for } i = \{1, 2, \dots, t\} \right\}$$

and

$$\mathcal{F} = \mathcal{F}(H, f) := \left\{ F \subseteq \widehat{G} : \begin{array}{l} \exists \alpha_1, \dots, \alpha_t \in H, \exists \varepsilon > 0 \\ \text{such that } F(\alpha_1, \dots, \alpha_t, \varepsilon) \subseteq F \end{array} \right\}.$$

We have to show that

- (a) \mathcal{F} is a filter.
- (b) For all $\alpha \in H : \mathcal{F} - \lim_\chi \chi(\alpha) = f(\alpha)$.
- (c) For all $\beta \notin H : \mathcal{F} - \lim_\chi \chi(\beta)$ does not exist.

ad (a): Since the set $F(\alpha_1, \dots, \alpha_t, \beta_1, \dots, \beta_t, \min(\varepsilon_1, \varepsilon_2)) \in \mathcal{F}$ is contained in $F(\alpha_1, \dots, \alpha_t, \varepsilon_1) \cap F(\beta_1, \dots, \beta_t, \varepsilon_2)$ it suffices to show that each $F(\alpha_1, \dots, \alpha_t, \varepsilon)$ is not empty.

There exists an extension of $f : H \rightarrow \mathbb{T}$ to $\chi : G \rightarrow \mathbb{T}$ such that $\chi \in \widehat{G}_d$. By Lemma 2.2.2 there is a $\chi' \in \widehat{G}$ such that $\|\chi'(\alpha_i) - \chi(\alpha_i)\| \leq \varepsilon$ for $i = 1, \dots, t$. Hence $\chi' \in F(\alpha_1, \dots, \alpha_t, \varepsilon) \neq \emptyset$.

ad (b): Let $\alpha \in H$ and $U \in \mathcal{U}(f(\alpha))$. There exists an $\varepsilon > 0$ such that $\|\xi - f(\alpha)\| < \varepsilon$ implies $\xi \in U$. $\chi \in F(\alpha, \varepsilon) \in \mathcal{F}$ implies $\|\chi(\alpha) - f(\alpha)\| < \varepsilon$ proving $\mathcal{F} - \lim_\chi \chi(\alpha) = f(\alpha)$.

ad (c): Let $\beta \notin H$ and $F \in \mathcal{F}$ be arbitrary. We will show that there exist $\chi_1, \chi_2 \in F$ such that $\|\chi_1(\beta) - \chi_2(\beta)\| \geq 1/4$. $F \in \mathcal{F}$ implies that there exist $\alpha_1, \dots, \alpha_t \in H$ and $\varepsilon > 0$ such that $F(\alpha_1, \dots, \alpha_t, \varepsilon) \subseteq F$. Note that there is a $\chi' \in \widehat{G}_d$ with $\chi'(h) = 0$ for all $h \in H$ and $\chi'(\beta) \geq 1/3$. By Lemma 2.2.2 there exists a $\chi \in \widehat{G}$ such that $\|\chi(\alpha_i)\| < \varepsilon/2$ for $i = 1, \dots, t$ and $\chi(\beta) > 1/4$. Pick $\chi_1 \in F(\alpha_1, \dots, \alpha_t, \varepsilon/2) \subseteq F$ arbitrary and let $\chi_2 = \chi + \chi_1$. Then χ_2 is also in F and $\|\chi_2(\beta) - \chi_1(\beta)\| = \|\chi(\beta)\| > 1/4$.

3. Let $H = \{\alpha_t, t \in \mathbb{N}\}$. The proof of 2. shows that for each $n \in \mathbb{N}$ there is a $\chi_n \in \widehat{G}$ such that $\|\chi_n(\alpha_i) - f(\alpha_i)\| < 1/n$ for $i = 1, \dots, n$. The sequence $(\chi_n)_{n=1}^\infty$ has the desired properties.

4. If G is metrizable and H is countable we know by Theorem 2.2.3 that there exists a sequence $(\widetilde{\chi}_n)_{n=1}^\infty$ in \widehat{G} such that

$$\|\widetilde{\chi}_n(\alpha)\| \rightarrow 0 \quad \text{iff} \quad \alpha \in H.$$

Let furthermore $(\chi_n)_{n=1}^\infty$ be as in 3. and define $\chi'_{2n} := \chi_n$ and $\chi'_{2n+1} := \chi_n + \widetilde{\chi}_n$. Then $\chi'_n(\alpha) \rightarrow f(\alpha)$ for all $\alpha \in H$.

Conversely, for $\beta \notin H$ the sequence $(\chi'_n(\beta))_{n=1}^\infty$ cannot converge: If $\chi'_n(\beta) \rightarrow c$ for some $c \in \mathbb{T}$, then $\widetilde{\chi}_n(\beta) = \chi'_{2n+1}(\beta) - \chi'_{2n}(\beta) \rightarrow 0$. Hence $\beta \in H$, contradiction. ■

We want to apply Theorem 2.2.11 to Question 5.4 in [5] which, in our notation, reads as follows. Let $(c_n)_{n=1}^\infty$ be a sequence in \mathbb{Z} . Are the subsequent conditions (i) and (ii) equivalent?

- (i) There exists a precompact abelian group $G \supseteq \mathbb{Z}$ such that $c_n \rightarrow h$ in G and $\langle h \rangle \cap \mathbb{Z} = \{0\}$.
- (ii) There exists an infinite subgroup $A \leq \mathbb{T}$ such that $c_n \alpha \rightarrow 0$ holds for all $\alpha \in A$.

Conditions (i) is obviously equivalent to (i') below:

- (i') There exists a group compactification (ι, G) of \mathbb{Z} such that ι is 1-1, $\iota(c_n) \rightarrow h$ in G and $\langle h \rangle \cap \iota(\mathbb{Z}) = \{0\}$.

We remark first that (ii) implies (i'): Let $A \leq \mathbb{T}$ be the subgroup such that $c_n \alpha \rightarrow 0$ holds for all $\alpha \in A$. Then let $\iota : \mathbb{Z} \rightarrow \mathbb{T}^A, n \mapsto (n\alpha)_{\alpha \in A}$ and

put $G = \overline{\iota(\mathbb{Z})}$. Obviously (ι, G) is a compactification of \mathbb{Z} and since A is infinite, ι is 1-1. Moreover $\iota(c_n) \rightarrow 0 \in G$, thus (i') holds for $h = 0$.

To see that the converse does not hold, pick $\alpha, \beta \in \mathbb{T}$, such that α and β are linearly independent over the rationals. Define a homomorphism $f : \langle \alpha \rangle \rightarrow \langle \beta \rangle, n\alpha \mapsto n\beta$. By Theorem 2.2.11 choose a sequence $(c_n)_{n=1}^\infty$ in \mathbb{Z} such that $c_n\alpha \rightarrow f(\alpha) = \beta$ and $(c_n\gamma)_{n=1}^\infty$ does not converge for $\gamma \in \mathbb{T} \setminus \langle \alpha \rangle$.

Then $\iota : \mathbb{Z} \rightarrow \mathbb{T}, n \mapsto n\alpha$ gives rise to a group compactification of \mathbb{Z} . Put $h := \beta$ such that $\iota(c_n) = c_n\alpha \rightarrow \beta$. Since α and β were chosen to be linearly independent we have $\langle h \rangle \cap \iota(\mathbb{Z}) = \langle \beta \rangle \cap \langle \alpha \rangle = \{0\}$. Thus (i') is valid. On the other hand (ii) fails since $c_n\gamma \rightarrow 0$ only for $\gamma = 0$.

For a different type of counterexample fix a prime p and consider the p -adic integers \mathbb{Z}_p . Choose an arbitrary sequence $(k_n)_{n=1}^\infty$ in $\{0, 1, \dots, p-1\}$ which contains infinitely many non zero elements and satisfies $k_1 = 1$. Using this, put for each $n \in \mathbb{N}$, $h_{2n} = h_{2n+1} = \sum_{i=1}^n k_i p^i$ and let $c_n = p^n + h_n$. Then

$$\lim_{n \rightarrow \infty} c_n = \lim_{n \rightarrow \infty} h_n = \sum_{i=1}^{\infty} k_i p^i =: h \in \mathbb{Z}_p \setminus \mathbb{Z}.$$

Hence $kh \in \mathbb{Z}_p \setminus \mathbb{Z}$ for all $k \in \mathbb{Z} \setminus \{0\}$, so (i) holds.

Next pick $\alpha \in \mathbb{T}$ such that

$$\lim_{n \rightarrow \infty} c_n \alpha = 0.$$

It follows that also $\lim_{n \rightarrow \infty} (c_{n+1} - c_n)\alpha = 0$. Since $h_{2n} = h_{2n+1}$ this yields $p^n \alpha \rightarrow 0$ so $\alpha = a/p^l + \mathbb{Z}$ for some $l \in \mathbb{N}$ and $a \in \{0, 1, \dots, p^l - 1\}$. But then, for all $n \geq l$

$$\|c_{2n}\alpha\| = \left\| \left(p^{2n} + \sum_{i=1}^n k_i p^i \right) (a/p^l) \right\| = \left\| \sum_{i=1}^l k_i p^i (a/p^l) \right\|.$$

The last term tends to 0 only if $a = 0$. Hence $\alpha = 0$ and (ii) fails.

2.3 Reconstruction of Hartman sequences

In this section we take up the interesting reconstruction problem of finding the minimal compactification in which a continuity set M which induces a given Hartman set H can be realized in.

2.3.1 The abstract approach

[44]

We start with the following question. Let (α_1, α_2) generate \mathbb{T}^2 , i.e. assume they are linearly independent. Let $H = B_{\alpha_1, \alpha_2, \varepsilon} = \{k \in \mathbb{Z} : \|k\alpha_i\| \leq \varepsilon, i = 1, 2\}$ a Bohr set. Is it possible to find a continuity set M and a $\beta \in \mathbb{T}$ such that $H = \iota_\beta^{-1}(M)$? More general one can ask (following Section 1.2): How much information about its corresponding continuity set M and the minimal compactification M is realized in is contained in a given Hartman set $H \subseteq \mathbb{Z}$? Section 2.1 showed that in the case of Bohr sets already the complexity determines the dimension d of the minimal compactification. We will sketch the main ideas how to obtain all the information from a given Hartman set H one can ask for.

As indicated in Section 1.2 there is a direct connection between a compactification (C, ι) and the subgroup of generating elements $A \leq \mathbb{T}$. Each compactification is determined by its Bohr sets i.e. sets generating a base of the neighborhood of 0. We will focus on the question how to obtain information from H about the neighborhood of 0 of the corresponding compactification.

We will again use filters and filter limits as introduced in Section 2.2.

Roughly spoken two things have to be done: Extract information from H and check how this determines (C, ι) . The neighborhood system of 0, $\mathcal{U}(0)$, in C is a filter. Let

$$\mathcal{F} = \mathcal{F}(C) = \{F \subseteq \mathbb{Z} : (\exists U \in \mathcal{U}(0)) \iota^{-1}(U) \subseteq F\}.$$

Then \mathcal{F} is a filter on \mathbb{Z} . Note that \mathcal{F} is the filter introduced in Section 2.2.3 without the cofiniteness property we needed there. By Theorem 2.2.1, if $(C, \iota) = (C_A, \iota_A)$ then $\alpha \in A \leq \mathbb{T}$ iff $\mathcal{F} - \lim_k (k\alpha) = 0$. Thus \mathcal{F} determines A and thus the corresponding compactification. Is it possible to obtain \mathcal{F}

also from $H = \iota^{-1}(M)$? Let, for $k \in \mathbb{Z}$, $H_k = H \Delta (H + k)$ and, for $c \in C$, $M_c = M \Delta (M + c)$. It is natural to assume that an element kg , $g = \iota_A(1)$ denotes the generating element of C_A , is close to 0 in C if

$$\mu_C(M_{kg}) = \text{dens}(H_k)$$

is small, where μ_C is the Haar measure of C . This equality holds since M_c is also a continuity set for all $c \in C$. Motivated by this we define

$$F(H, \varepsilon) = \{k \in \mathbb{Z} : \text{dens}(H_k) \leq \varepsilon\},$$

$\varepsilon > 0$, and

$$\mathcal{F}_H := \{F \subseteq \mathbb{Z} : (\exists \varepsilon > 0) \mathcal{F} \supseteq F(H, \varepsilon)\}.$$

Let furthermore

$$f_M : C \rightarrow \mathbb{R}, \quad f_M(c) = \mu_C(M_c)$$

and $Z(M) = \{c \in C : f_M(c) = 0\}$. We call M aperiodic if $Z(M) = \{0\}$. Then, by [44], the following holds:

Theorem 2.3.1 *Let $M \subseteq C$ be a continuity set and $H = \iota_A^{-1}(M)$. Then*

1. $\mathcal{F}_H \subseteq \mathcal{F}$.
2. If $Z(M) = \{0\}$ then $\mathcal{F}_H \supseteq \mathcal{F}$.
3. If $Z(M) \neq \{0\}$ then $Z(M) \leq C$ and $\mathcal{F}_H = \mathcal{F}(C/Z(M))$.

Summing up, this shows that the filter \mathcal{F}_H induced by the given Hartman set H determines the neighborhood filter of C and a fortiori also the continuity set M related to H (up to zero sets). In this sense, H contains all the essential information we can expect. Moreover, Theorem 2.3.1 tells us how to obtain this information.

Returning to the question stated at the beginning of this section Theorem 2.3.1 implies that H cannot be induced by any continuity set $M \subseteq \mathbb{T}$ ($B_{\alpha_1, \alpha_2, \varepsilon}$ is clearly aperiodic).

2.3.2 Comments on the function f_M

Let us first discuss the following example. To simplify matters, we will, again, define sets on \mathbb{T}^d by defining them on the unit cube $[0, 1]^d$. Let $M = I = [a, b] \subseteq \mathbb{T}$ be an interval and suppose $b - a \leq 1/2$. Then

$$f_M(x) = \begin{cases} 2x & 0 \leq x < b - a, \\ 2(b - a) & b - a \leq x < 1 - (b - a), \\ -2x & -(b - a) \leq x < 0. \end{cases}$$

More generally, it can be seen that for $M = \bigcup_{j=1}^N I_j$, I_j disjoint intervals, f_M grows like $2kx$ sufficiently close to 0. Let, for $M \in \mathbb{T}^d$, $D_M(\delta) = \{x \in \mathbb{T}^d : f_M(x) \leq \delta\}$. Then, in both cases discussed above, the function $m_M : \delta \mapsto \lambda^1(D_M(\delta))$ is (sufficiently close to 0) a linear polynomial. What about higher dimensions? If $M \subseteq \mathbb{T}^d$ has the shape of a d -dimensional sphere in $[0, 1]^d$, then obviously $\lambda^d(D_M(\delta))$ equals the volume of a sphere with radius ε' , for suitable $\varepsilon' > 0$. So m_M grows like a polynomial of degree d . To show a similar result for general convex subsets of \mathbb{T}^d we first discuss the related situation in \mathbb{R}^d .

In the sequel, for $A \subseteq \mathbb{R}^d$ and $v \in \mathbb{R}^d$, $A + v$ denotes the usual translation of A by v in \mathbb{R}^d and $A +_c v := \{x = a + \lambda v_0 \in \mathbb{R}^d : a \in A \text{ and } 0 \leq \lambda \leq \|v\|\}$, where $\|v\|$ denotes the length of the vector v and $v_0 = v/\|v\|$. (Thus $+_c$ is related to the complex sum). Let $\lambda^{d'}$ denote the d' -dimensional Lebesgue measure. In particular, $V = \lambda^d$ denotes the volume. Let $M \in \mathbb{R}^d$. Let $v \in S_{d-1}$. Then $\lambda^{d-1}(M|_v)$ is the measure of the (convex) body obtained by projection of M onto the hyperplane $x \cdot v = 0$ in \mathbb{R}^d . (For a convex set $M \subseteq \mathbb{R}^d$ and a vector $v \in S_{d-1}$, we write $M|_v$ for the set resulting from the projection of M onto the hyperplane $x \cdot v = 0$.) Finally let, related to above, $f_M : \mathbb{R}^d \rightarrow \mathbb{R}$, $f_M(x) = V(M \Delta (M + x))$.

Theorem 2.3.2 *Let M be a convex set in \mathbb{R}^d . Then*

1.

$$\frac{f_M(\varepsilon v)}{2\varepsilon} \rightarrow \lambda^{d-1}(M|_v) \quad (\varepsilon \rightarrow 0).$$

2.

$$\frac{V(D_M(\delta))}{\delta^d} \rightarrow c(M) \quad (\delta \rightarrow 0) \quad \text{and}$$

$$c(M) = \frac{1}{d2^d} \int_{S_{d-1}} \frac{1}{(\lambda^{d-1}(M|_v))^d} dv,$$

where $D_M(\delta) = \{x \in \mathbb{R}^d : f_M(x) \leq \delta\}$.

Proof: Let $u \in S_{d-1}$ and $\varepsilon > 0$. Set $M(\varepsilon u) = M \cap (M + \varepsilon u)$. Note that

$$V(M + {}_c\varepsilon u) - V(M) = V(M + {}_c\varepsilon u \setminus M) = \varepsilon \lambda^{d-1}(M|_u) \quad (2.2)$$

$$2(V(M + {}_c\varepsilon u) - V(M)) \geq V(M \Delta (M + \varepsilon u)) \quad (2.3)$$

$$2(V(M(\varepsilon u) + {}_c\varepsilon u) - V(M(\varepsilon u))) \leq V(M \Delta (M + \varepsilon u)). \quad (2.4)$$

Equation (2.2) is a direct consequence of the convexity of M . $M + {}_c\varepsilon u \supseteq M + \varepsilon u$ implies (2.3). Also (2.4) follows easily: $x \in M \cap (M + \varepsilon u)$ iff $x \in M$ and $x - \varepsilon u \in M$. M is convex, thus also $x - \varepsilon' u \in M$ for all $\varepsilon' \in [0, \varepsilon]$. Therefore $\bigcap_{r=0}^{\varepsilon} (M + ru) = M \cap (M + \varepsilon u)$. Thus, $x \in M(\varepsilon u)$ implies $x + ru \in M + \varepsilon u$ for all $0 < r < \varepsilon$. Hence $M(\varepsilon u) + {}_c\varepsilon u \subseteq M + \varepsilon u$ and $(M(\varepsilon u) + {}_c\varepsilon u) \setminus M(\varepsilon u) \subseteq (M + \varepsilon u) \setminus M$. A symmetric argument leads to $(M(\varepsilon u) + {}_c(-\varepsilon u)) \setminus M(\varepsilon u) \subseteq M \setminus (M + \varepsilon u)$. Summing up, we have

$$2\varepsilon \lambda^{d-1}(M(\varepsilon u)|_u) \leq f_M(\varepsilon u) \leq 2\varepsilon \lambda^{d-1}(M|_u). \quad (2.5)$$

Since clearly $M(\varepsilon u) \rightarrow M$ ($\varepsilon \rightarrow 0$) in the Hausdorff metric we obtain assertion 1. Conversely, (2.5) also implies $f_M(\varepsilon u) = \delta$ iff

$$\frac{\delta}{2\lambda^{d-1}(M|_u)} \leq \varepsilon \leq \frac{\delta}{2\lambda^{d-1}(M(\varepsilon u)|_u)}.$$

Thus, we have an upper and lower bound for the radius $\varepsilon(u)$. Integrating $(1/d\varepsilon(u))^d$ over the sphere yields the volume of $D_M(\delta)$ and proves 2. ■

Turning back to our observations on the torus, we use that a convex set $M \subseteq \mathbb{T}^d$ (thus M is a continuity set) can locally be interpreted as a convex set $M \subseteq [0, 1)^d \subseteq \mathbb{R}^d$ and apply the last assertion. Let $H = \iota^{-1}(M)$. Since $\text{dens}(H \Delta (H + k)) = \mu_C(M \Delta (M + \iota(k)))$, $k \in \mathbb{Z}$, we have

$$H(\delta) = \{k : \text{dens}(H \Delta (H + k)) \leq \delta\} = \{k : \mu_C(M \Delta (M + \iota(k))) \leq \delta\}.$$

It is easy to see that $D_M(\delta)$ is also a convex set. It induces the Hartman set $H(\delta)$. Theorem 2.3.2 shows that the growth rate of $\text{dens}(H(\delta))$, for $\delta \rightarrow 0$, already determines the dimension of the convex set M .

2.3.3 Bohr sets and explicit reconstruction

In this part we will apply and analyze some results of Section 2.2 for the special case $G = \mathbb{T}^d$ in the context of the reconstruction problem.

Let $M \subseteq \mathbb{T}^d$ be an aperiodic continuity set (thus $\mu_C(M) > 0$). Let the compactification $(C = \mathbb{T}^d, \iota)$ be determined by a generating vector $\iota(1) = \alpha = (\alpha_1, \dots, \alpha_d) \in \mathbb{T}^d$. Let $H = \iota^{-1}(M)$ be the induced Hartman set. Assume that $M \subseteq W = [-\varepsilon, \varepsilon]^d$ for some $\varepsilon \in (0, 1/4)$. Then

$$\begin{aligned} k \in H &\iff k\alpha \in M \\ &\implies k\alpha \in W \\ &\iff \alpha_i \in \underbrace{\bigcap_{k \in H} \bigcup_{i=1}^k \left[\frac{i-\varepsilon}{k}, \frac{i+\varepsilon}{k} \right]}_{=: G(M, \varepsilon, \alpha)}, \\ &\text{for all } i \in \{1, \dots, d\} \end{aligned}$$

We apply now assertions 1.–3. in Lemma 2.2.6 of Section 2.2. They say

- (A) $\beta \in \mathbb{T} \cap G(M, \varepsilon, \alpha)$ implies $\beta \in \langle \alpha_1, \dots, \alpha_d \rangle$.
- (B) There exists an $R \in \mathbb{N}$ such that $\beta \in \mathbb{T} \cap G(M, \varepsilon, \alpha)$ implies $\beta \in \langle \alpha_1, \dots, \alpha_d \rangle_R$.
- (C) For all $\delta > 0$ exists an $S \in \mathbb{N}$ such that

$$\beta \in \mathbb{T} \cap \underbrace{\bigcap_{\substack{k \in H \\ k \leq S}} \bigcup_{i=1}^k \left[\frac{i-\varepsilon}{k}, \frac{i+\varepsilon}{k} \right]}_{=: G(M, \varepsilon, \alpha, S)}$$

implies

$$\min \{ \|\beta - \alpha\| : \alpha \in \langle \alpha_1, \dots, \alpha_d \rangle_R \} \leq \delta.$$

The crucial points for an explicit reconstruction are clearly (B) and (C), i.e., how to obtain the numbers R and S . We first present two approaches implying (B) that have a more geometric flavor than the original proof of Lemma 2.2.6. According to our assumptions, $M \subseteq W = [-\varepsilon, \varepsilon]^d$.

Proposition 2.3.3 Let $A \in \mathbb{Z}^{d \times d}$ be a $d \times d$ integer matrix. Let H be a Hartman set induced by the coding of the continuity set $M \subseteq \mathbb{T}^d$. Then $\beta \in \mathbb{T} \cap G(M, \varepsilon, \alpha)$ iff β is a component of the vector $A(\alpha)$ and $A(M) \subseteq W$.

Proof: Let $H\alpha = \{k\alpha : k \in H\}$ and $\|H\alpha\| = \sup_{k \in H} \|k\alpha\|$. Note that $HA(\alpha) = A(H\alpha)$. Thus

$$\|HA(\alpha)\| \leq \varepsilon \Leftrightarrow \|A(H\alpha)\| \leq \varepsilon \Leftrightarrow \|A(M)\| \leq \varepsilon.$$

The last implication follows from density of the set $H\alpha$ in M . ■

A second way to see (B) is to use that H has positive uniform density and thus has bounded gaps.

Proposition 2.3.4 Let $H = \{h_i : i \in \mathbb{N}, h_i < h_{i+1} \text{ for all } i\}$. Let $g \in \mathbb{N}$ such that $h_{i+1} - h_i \leq g$ for all $i \in \mathbb{N}$. Let $\varepsilon < 1/4$. Let

$$U(L) = \bigcap_{l=1}^L \bigcup_{i=1}^{h_l} \left[\frac{i - \varepsilon}{h_l}, \frac{i + \varepsilon}{h_l} \right]$$

be a set of $I(L)$ disjoint intervals. Then $(1/(4\varepsilon) - 1)h_L > g$ implies $I(L) \geq I(L + 1)$.

Proof: Let L be large enough that $(1/(4\varepsilon) - 1)h_L > g$. We show that each interval occurring in $U(L)$ is intersected by at most one interval of

$$V(L + 1) = \bigcup_{i=1}^{h_{L+1}} \left[\frac{i - \varepsilon}{h_{L+1}}, \frac{i + \varepsilon}{h_{L+1}} \right].$$

For this observe that

$$\begin{aligned} & (1/(4\varepsilon) - 1)h_L > g \\ \Rightarrow & (1 - 4\varepsilon)h_L > 2\varepsilon g \\ \Leftrightarrow & (1 - 2\varepsilon)h_L > 2\varepsilon(h_L + g) \\ \Rightarrow & (1 - 2\varepsilon)h_L > 2\varepsilon(h_{L+1}) \\ \Leftrightarrow & \frac{1 - 2\varepsilon}{h_{L+1}} > \frac{2\varepsilon}{h_L}. \end{aligned}$$

The left side of the last inequality is the length of a gap between two intervals in $V(L + 1)$. The right side of the last inequality is the maximal length of

one interval in $U(L)$. ■

This, of course, also implies (B). In Section 2.2 the assertion (C) was shown by compactness. (C) states that all "bad" intervals obtained by Proposition 2.3.4, not containing an element of the set $\langle \alpha_1, \dots, \alpha_d \rangle_R$, vanish if S is sufficiently large. It would be interesting to have explicit bounds for S , replacing the original compactness argument – unfortunately this seems to be a very difficult problem. Nevertheless explicit examples indicate that "bad" intervals drop out after few steps. So far we did not use that M is a continuity set. Nevertheless, we already have the following proposition.

Proposition 2.3.5 *Let $(C = \mathbb{T}^d, \iota)$ be a compactification generated by $\iota(1) = \alpha = (\alpha_1, \dots, \alpha_d)$. Let $M \subseteq \mathbb{T}^d$ be a set with nonempty interior and $H = \iota^{-1}(M)$.*

1. *If $M \not\subseteq [-\varepsilon, \varepsilon]^d$, then $G(M, \varepsilon, \alpha) = \emptyset$.*
2. *If $M \subseteq [-\varepsilon, \varepsilon]^d$, then*

$$G(M, \varepsilon, \alpha) = \left\{ \beta \in \mathbb{T}^d : \begin{array}{l} \exists A \in \mathbb{Z}^{d \times d} \text{ such that} \\ A(M) \subseteq [-\varepsilon, \varepsilon]^d \text{ and } \beta = A(\alpha) \end{array} \right\}.$$

Hence $G(M, \varepsilon, \alpha)$ is finite. Moreover, for every $\delta > 0$ there exists an $S \in \mathbb{N}$ such that $G(M, \varepsilon, \alpha, S) \subseteq G(M, \varepsilon, \alpha) + (-\delta, \delta)$.

Using $\text{dens}(H) = \mu(M)$ the procedure described so far allows filter out finitely many vectors $A(\alpha)$, where $A \in \mathbb{Z}^{d \times d}$ with $|\text{Det}A| = 1$. Clearly, $\iota(1)$ is among the set of possible candidates.

So far we assumed that $M \subseteq [-\varepsilon, \varepsilon]^d$. Let now M be an arbitrary aperiodic continuity set in (\mathbb{T}^d, ι) . Thus M is of positive measure. Let H be the Hartman set induced by a coding of M via $\iota(1) = \alpha \in \mathbb{T}^d$. Then we can combine the idea introduced in Section 2.3.1 with Proposition 2.3.5: Let $M_\delta := \{x \in \mathbb{T}^d : f_M(x) \leq \delta\}$. Let $\varepsilon \in (0, 1/3)$. Proposition 2.3.5,1. allows to determine $\delta_1 = \sup\{\delta : G(M_\delta, \varepsilon, \alpha) \neq \emptyset\}$. Then Proposition 2.3.5,2. implies that $G(M_{\delta_1}, \varepsilon, \alpha)$ consists of α and finitely many images of α under certain linear mappings A as described above.

Chapter 3

Complexity induced by polytopes

[31], [36], [37], [38]

The objective of this chapter is to extend the ideas presented in Section 2.1. Motivated by Remark 2.1.2,1., we want to clarify the interplay between the geometry of the coded continuity set $M \subseteq \mathbb{T}^d$ and the complexity of the induced Hartman sequence. Therefore we deduce an asymptotic formula for the complexity of Hartman sequences induced by polytopes. This will provide a connection between the complexity function and the geometry of the corresponding continuity set. As in Section 2.1, the main tool will be an estimation of the local complexity induced by the polytopes.

3.1 Notation

We use the following abbreviations: We call a vector $\alpha = (\alpha_1, \dots, \alpha_d)$ strongly irrational if $\overline{\mathbb{N}\alpha} = \mathbb{T}^d$. As before, for a set $M \subseteq \mathbb{T}^d$ and an $\alpha \in \mathbb{T}^d$, we call the sequence $\mathbf{a} = \mathbf{a}(M, \alpha) = (a(M, \alpha)_n)_{n=-\infty}^{\infty} \in \{0, 1\}^{\mathbb{Z}}$ defined by

$$a_n = \begin{cases} 1 & \text{if } n\alpha \in M, \\ 0 & \text{otherwise} \end{cases}$$

a coding sequence. Let, for $M \subseteq \mathbb{T}^d$, $\mathbf{a} = \mathbf{a}(M, \alpha)$ be such a coding sequence. Recall that the complexity $P_{S, \alpha}(N)$ is the number of distinct words of length

$N \in \mathbb{N}$ occurring in \mathbf{a} . Since the complexity function is either bounded or strictly increasing

$$\mathcal{P}(d, M, \alpha) = \lim_{N \rightarrow \infty} \frac{P_{M, \alpha}(N)}{N^d}, \quad \text{for } d \in \mathbb{N},$$

is either 0, ∞ or in \mathbb{R}^+ . If there exists a $d_0 \in \mathbb{N}$ such that $\mathcal{P}(d_0, M, \alpha) \in \mathbb{R}^+$, we call $\mathcal{P}(M, \alpha) := \mathcal{P}(d_0, M, \alpha)$ the asymptotic complexity of M and α .

3.1.1 Polytopes in \mathbb{T}^d

S_{d-1} denotes the d -dimensional sphere, S_{d-1}^+ the d -dimensional upper half-sphere and B_ε the (d -dimensional) ball with radius $\varepsilon > 0$ and center 0. For $u \in S_{d-1}$ and $\lambda \in \mathbb{R}$, the set

$$H_{u, \lambda} := \{x \in \mathbb{R}^d : x \cdot u = \lambda\}$$

defines a hyperplane in the Euclidean space \mathbb{R}^d (\cdot denotes the usual inner product) and

$$H_{u, \lambda}^+ := \{x \in \mathbb{R}^d : x \cdot u > \lambda\} \quad \text{and} \quad H_{u, \lambda}^- := \{x \in \mathbb{R}^d : x \cdot u \leq \lambda\}$$

the induced halfspaces. A (general bounded) polytope P is a bounded region of the d -dimensional space enclosed by a finite number of hyperplanes. We always assume that P has nonempty interior. In particular, a polytope P in \mathbb{R}^d is convex if and only if it can be determined via

$$P = \bigcap_{r=1}^L H_{u_r, \lambda_r}^-$$

$u_r \in S_{d-1}$ and $\lambda_r \in \mathbb{R}$, $r = 1, \dots, L$. (We use outer normal vectors to determine P .) Each polytope is a finite union of convex polytopes.

As usual, we call the $(d-1)$ -dimensional subsets of the boundary ∂P of P facets (thus, for each facet F holds $F = \partial P \cap H_{u, \lambda}$), the 1-dimensional subsets edges and the 0-dimensional subsets vertices. A parallelepiped D is also given by d linearly independent vectors $u_1, \dots, u_d \in S_{d-1}^+$ and $\lambda_1, \dots, \lambda_d, \delta_1, \dots, \delta_d$ in \mathbb{R} via

$$D = \bigcap_{r=1}^d H_{u_r, \lambda_r}^+ \cap \bigcap_{r=1}^d H_{u_r, \lambda_r + \delta_r}^-$$

$C(\sigma, x) = (x - \sigma/2, x + \sigma/2]^d$ denotes a half open cube with center $x \in \mathbb{R}$ and side-length σ .

As already discussed in Remark 1.1.26, we will define sets on \mathbb{T}^d by defining them as subset of the d -dimensional unit cube $[0, 1]^d \subseteq \mathbb{R}^d$ (so before identifying its opposite facets). Thus, a polytope P in \mathbb{T}^d is (a translate by an $x \in \mathbb{T}^d$ of) a polytope $P \subseteq [0, 1]^d$. In the sequel, we will restrict ourselves to the case that P is a closed polytope. In particular, we will write $F \subseteq H_{u, \lambda}$, $u \in S_{d-1}$, $\lambda \in \mathbb{R}$, for a facet F of a polytope $P \subseteq \mathbb{T}^d$ if the facet F of P , interpreted as subset of $[0, 1]^d$, lies in the hyperplane $H_{u, \lambda}$ of \mathbb{R}^d . Analogously, a set in $C \subseteq \mathbb{T}^d$ is called convex if it is (a translate of) a convex set in $[0, 1]^d$.

Since the d -dimensional Haar measure on \mathbb{T}^d coincides with the d -dimensional Lebesgue measure on $[0, 1]^d$, we will denote both by λ^d .

3.1.2 Partition sets and local complexity

Let $P \subseteq \mathbb{T}^d$ be a polytope, $C \subseteq \mathbb{T}^d$ an arbitrary set and $\alpha = (\alpha_1, \dots, \alpha_d) \in \mathbb{T}^d$ strongly irrational. Let $\mathbf{a} = \mathbf{a}(P, \alpha) = (a(P, \alpha)_k)_{k=-\infty}^{\infty} \in \{0, 1\}^{\mathbb{Z}}$ be the resulting coding sequence. Denote by

$$W(C, N) = W(C, N, P, \alpha) = \{w = a_k a_{k+1} \cdots a_{k+N-1} \in \{0, 1\}^N : k\alpha \in C\}$$

the set of all words w of length N starting in C and induced by P and α .

Definition 3.1.1 *We call*

$$P(C, N) = P(C, N, P, \alpha) = |W(C, N, P)|$$

the local complexity of C induced by P and α .

Following Section 1.4.1, for a word $w = a_k a_{k+1} \cdots a_{k+N-1}$, $w \in W(C, N)$ is equivalent to the fact that its induced partition set

$$P_w := \bigcap_{j=0}^{N-1} (C \cap (P^{a_{k+j}} - j\alpha)),$$

$P^1 := P$ and $P^0 := \mathbb{T}^d \setminus P$, is nonempty. Thus to obtain the local complexity of C it suffices to compute the number of partition sets in C induced by N translates of P by α . Under certain assumptions it turns out that we can concentrate on the d -dimensional partition sets. These assumptions are stated in the next section.

3.1.3 Independence of $P \subseteq \mathbb{T}^d$ and $\alpha \in \mathbb{T}^d$

In Section 2.1 we assumed some independence condition of the coded cube and the generating element α to be able to count the partition sets yielding the local complexity. As pointed out in Remark 2.1.2,2, the asymptotic formula changes if one drops this independence condition. For the estimate of the number of partition sets induced by a polytope we again need some independence condition which we are going to formulate in the present section.

Let P be a polytope in the d -dimensional torus with facets $F_r \subseteq H_{u_r, \lambda_r}$, $r = 1, \dots, L$, and let $\alpha \in \mathbb{T}^d$ strongly irrational. It is natural to call a point $x \in \mathbb{T}^d$ a vertex (after N translations) if x can be written as an intersection of d translates of d linearly independent facets F_r (i.e., if there exist $n_r \in \{0, 1, \dots, N-1\}$, $r = 1, \dots, d$, such that $\{x\} = \bigcap_{r=1}^d (F_r - n_r \alpha)$). For our estimates we need a condition which guarantees that there are not too many over-determined vertices in \mathbb{T}^d induced by the orbit $(P - n\alpha)_{n \in \mathbb{N}}$, i.e., that the set

$$\left\{ x \in \mathbb{T}^d : \begin{array}{l} \text{there exists } d+1 \text{ distinct facets } F_r \text{ and} \\ \text{there exist } d+1 \text{ integers } n_r \text{ such that} \\ \{x\} = \bigcap_{r=1}^{d+1} (F_r - n_r \alpha) \end{array} \right\}$$

is sufficiently small.

We even assume that the orbit of a slightly enlarged version on P does not generate too many over-determined vertices. More precisely: Let $c > 0$. Set

$$\begin{aligned} F_r^{+c} &= (F_r + B_c) \cap H_{u_r, \lambda_r} \quad \text{and} \\ F_r^{-c} &= F_r \setminus \left(\bigcup_{\substack{s=1 \\ s \neq r}}^L (F_s + B_c) \right). \end{aligned}$$

(B_c denotes the ball with radius c centered at 0 and $+$ denotes the complex sum.) Fix $\sigma' > 0$ small enough such that $F_r^{\sigma'}$ is totally contained in $[0, 1)^d$ for all $r \in \{1, \dots, L\}$. Let $\partial P^{\sigma'} = \bigcup_{i=1}^L F_r^{\sigma'}$ (cf. Figure 3.1).

Then, define

$$C_r(N) := \left\{ x \in F_r^{\sigma'} : \begin{array}{l} \exists n_1, n_2, \dots, n_d \in \{0, \dots, N-1\}, \\ \exists r_j \in \{1, \dots, L\} \setminus \{r\}, j = 1, \dots, d, \\ r_i \neq r_j \text{ if } i \neq j, \\ \{x\} = F_r^{\sigma'} \cap \bigcap_{j=1}^d (F_{r_j}^{\sigma'} - n_j \alpha) \end{array} \right\}.$$

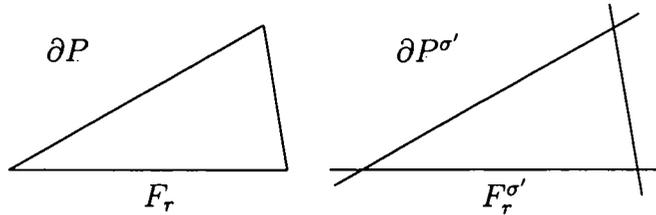

Figure 3.1: The enlarged boundary $\partial P^{\sigma'}$

Thus, for $r \in \{1, 2, \dots, L\}$, $C_r(N)$ is the set of all over-determined points x on a fixed facet F_r induced by $\partial P^{\sigma'} - n\alpha$, $n = 0, 1, \dots, N - 1$. Furthermore define $c(N) := \max_{j \in \{1, \dots, L\}} |C_j(N)|$. $c(N)$ is hence the maximal number of over-determined vertices on a facet of $\partial P^{\sigma'}$ after the N -fold translation of $\partial P^{\sigma'}$ by α .

Definition 3.1.2 P and α are called σ' -asymptotically independent (abbreviated σ' -a.i.) if

1. $c(N) = o(N^{d-1})$ and
2. there exists no $n \in \mathbb{N}$ such that $(\partial P^{\sigma'} - n\alpha) \cap \partial P^{\sigma'}$ contains a $(d - 1)$ -dimensional set.

The first condition of the last definition guarantees that the number of over-determined vertices is sufficiently small for our methods. The second condition implies that each point x lies on at most L translates of facets $F_r^{\sigma'}$, $r = 1, \dots, L$, by α .

Observe that in the case $d = 1$ conditions 1. and 2. of Definition 3.1.2 coincide.

Let P be a fixed polytope in \mathbb{T}^d . Pick an arbitrary $\alpha \in \mathbb{T}^d$. Then, as we will see in Section 3.4, typically P and α are σ' -a.i..

3.1.4 Definition of a measure preserving mapping

For the sake of simplicity, we compute instead of the local complexity of a cube C the local complexity of a parallelepiped. This parallelepiped is the

image of C under a measure preserving mapping which we are going to define now.

Let $C = C(\sigma, x)$ be a cube of side length σ and center x . Let C_0 be its translate, rooted at 0, i.e., with the edges $e_r^0 = \sigma e_r$ where e_r denotes the r -th Euclidean unit vector. Let $W = \{w_1, w_2, \dots, w_d\}$ be a set of d linearly independent vectors in S_{d-1} .

We define a measure preserving mapping A_W such that $A_W(C)$ is a parallelepiped whose facets have normal vectors w_r , $r = 1, 2, \dots, d$. $A_W(C)$ will be used to estimate the local complexity of C . For the definition of A_W , we use mappings τ_k , $k = 1, \dots, d$, iteratively defined. For $k = 1, 2, \dots, d$, each τ_k transforms the parallelepiped $C_{k-1} = \tau_{k-1} \circ \tau_{k-2} \circ \dots \circ \tau_1(C)$ into a parallelepiped C_k such that C_k has facets whose set of normal vectors contains w_1, \dots, w_k . Moreover, C_{k-1} and C_k have the same volume. (cf. Figure 3.2.)

For this reason we define the mappings τ_k , $k = 1, \dots, d$, as follows: To keep notations simple, we assume, w.l.o.g., that the elements of W are ordered so that $|e_1 \cdot w_1| = \max \{|e_1 \cdot w_j| : j \in \{1, \dots, d\}\}$. Then set

$$C_1 = \tau_1(C) = \begin{cases} C_0 & \text{if } |e_1 \cdot w_1| = 1, \\ \bigcap_{r=2}^d H_{e_r, 0}^+ \cap \bigcap_{r=2}^d H_{e_r, \sigma}^- \\ \cap H_{w_1, 0}^+ \cap H_{w_1, |e_1^0 \cdot w_1|}^- & \text{otherwise.} \end{cases}$$

Suppose now that the parallelepiped C_k with facets $F_r^k \subseteq H_{w_r, 0}$ and $F_{r+d}^k \subseteq H_{w_r, \rho_r^k}$, $r = 1, \dots, k$, and $F_r^k \subseteq H_{e_i, 0}$ and $F_{r+d}^k \subseteq H_{e_r, \rho_r^k}$, $r = k+1, \dots, d$, and edges e_r^k , $r = 1, \dots, d$, is defined in this fashion. Assume moreover that the elements of W are ordered so that

$$|e_{k+1} \cdot w_{k+1}| = \max \{|e_{k+1} \cdot w_j| : j \in \{k+1, \dots, d\}\}.$$

Then set

$$C_{k+1} = \tau_{k+1}(C_k) = \begin{cases} C_k & \text{if } |e_{k+1} \cdot w_k| = 1, \\ \bigcap_{r=1}^k H_{w_r, 0}^+ \cap \bigcap_{r=1}^k H_{w_r, \rho_r^k}^- \\ \cap H_{w_{k+1}, 0}^+ \cap H_{w_{k+1}, |e_{k+1}^k \cdot w_{k+1}|}^- \\ \cap \bigcap_{r=k+2}^d H_{e_r, 0}^+ \cap \bigcap_{r=k+2}^d H_{e_r, \rho_r^k}^- & \text{otherwise.} \end{cases}$$

Finally, set

$$A_W(C) = \tau_d \circ \tau_{d-1} \circ \dots \circ \tau_1(C).$$

For the sake of notational simplicity we set $A_W(C) = \emptyset$ iff the set W contains d linearly dependent vectors.

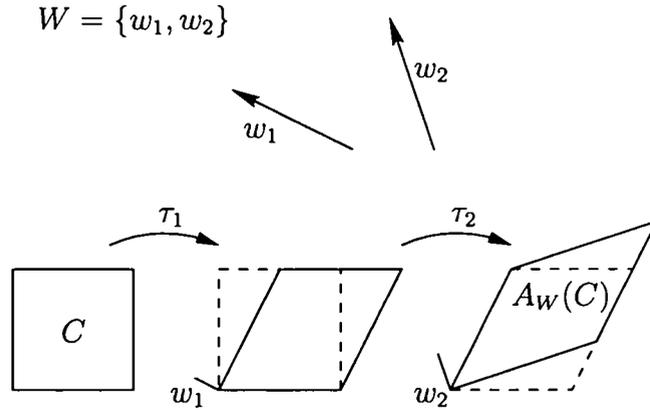

Figure 3.2: The mappings τ_i

Each τ_i , $i \in \{1, \dots, d\}$, and therefore also A_W is measure preserving. Note, furthermore, that all facets of C_k lie in the same hyperplanes as the facets of C_{k+1} except those two facets with normal vector e_k which are replaced by facets with normal vector w_{k+1} . Therefore the facets of C_k with normal vectors w_r , $i \in \{1, \dots, k\}$, lie in the same hyperplanes as the facets of $A_W(C)$ with normal vectors w_r , $r \in \{1, \dots, k\}$. Moreover, if σ , the side length of C , is sufficiently small, then (a translate of) $A_W(C) \subseteq [0, 1]^d$. Since there are only finitely many choices $W \subseteq \{u_r : 1 \leq r \leq L\}$ such a $\sigma > 0$ always exists. We introduce the following notion.

Definition 3.1.3 For a polytope $P \subseteq \mathbb{T}^d$ with facets $F_r \subseteq H_{u_r, \lambda_r}$, i.e., with normal vectors u_r , $r = 1, \dots, L$, and the measure preserving transformation A_W , $W \subseteq \{u_r : 1 \leq r \leq L\}$, defined above, we call

$$\xi(P) = \max_{\substack{W = \{u_{i_1}, u_{i_2}, \dots, u_{i_d}\} \subseteq \\ \{u_1, u_2, \dots, u_L\}}} (\text{diam}(A_W([0, 1]^d)))$$

the extension factor (abbreviated x.t.-factor) of P .

This definition guarantees that $\text{diam}(A_W(C(\sigma, x))) \leq \xi(P)\sigma$ holds for any cube $C(\sigma)$ and any choice of $W = \{u_{r_1}, \dots, u_{r_d}\}$.

3.1.5 The separation number

In this section we show a technical lemma. It guarantees that the local complexity can be used to estimate the asymptotic growth rate of the complexity function.

Let $P \subseteq \mathbb{T}^d$ be a polytope with facets F_r , $r = 1, \dots, L$. Then, for $r \in \{1, \dots, L\}$ and $\theta > 0$,

$$G_r := F_r \cap \bigcup_{\substack{s=1 \\ s \neq r}}^L (F_s + B_{2\theta}),$$

is a subset of F_r ($B_{2\theta}$ denotes the ball with radius 2θ centered in 0 and $+$ is the complex sum). Note that if θ is small enough, then $G_r \neq \emptyset$.

Lemma 3.1.4 *Let $P \subseteq \mathbb{T}^d$ be a polytope with facets F_r , $r = 1, \dots, L$. Let $\theta > 0$ be sufficiently small such that $G_{r_i} \neq \emptyset$ for d indices r_1, \dots, r_d and such that the corresponding facets F_{r_i} have linearly independent normal vectors. Let $\alpha \in \mathbb{T}^d$ be strongly irrational. Let C^1 and C^2 be sets in \mathbb{T}^d with disjoint closure and with $\text{diam}(C^i) < \theta$, $i = 1, 2$. Then there exists a sufficiently large number $K \in \mathbb{N}$ such that there exist finitely many $n_1 \leq n_2 \leq \dots \leq n_K$ in \mathbb{N} and m_1, m_2, \dots, m_K in $\{0, 1\}$ such that*

$$\begin{aligned} \bigcup_{i=1}^K ((P^{m_i} - n_i \alpha) \cap C^1) &= C^1 \quad \text{and} \\ \bigcup_{i=1}^K ((P^{m'_i} - n_i \alpha) \cap C^2) &= C^2, \end{aligned}$$

where $P^m = \begin{smallmatrix} P \\ \mathbb{T} \setminus P \end{smallmatrix}$ if $m = \begin{smallmatrix} 1 \\ 0 \end{smallmatrix}$ and $m'_i = \begin{smallmatrix} 1 \\ 0 \end{smallmatrix}$ if $m_i = \begin{smallmatrix} 0 \\ 1 \end{smallmatrix}$.

Proof: According to the assumption that the sets C^i , $i = 1, 2$, are sufficiently small and with disjoint closure, we can find open sets U_1, U_2, \dots, U_K and V_1, V_2, \dots, V_K in \mathbb{T}^d and m_1, m_2, \dots, m_K in $\{0, 1\}$ such that

$$\begin{aligned} \bigcup_{i=1}^K ((P^{m_i} - x_i) \cap C^1) &= C^1 \quad \text{and} \\ \bigcup_{i=1}^K ((P^{m'_i} - y_i) \cap C^2) &= C^2, \end{aligned}$$

whenever $x_i \in U_i$ and $y_i \in V_i$. The equidistribution of the sequence $(n\alpha)_{n=1}^\infty$ implies then the assertion. ■

Let the numbers $n_1 \leq n_2 \leq \dots \leq n_K$ in \mathbb{N} be as in the last lemma. Then we say that n_1, n_2, \dots, n_K separate C_1 and C_2 .

Let $\Theta(P)$ be the supreme of all $\theta > 0$ such that $G_{r_i} \neq \emptyset$ for d indices r_1, \dots, r_d and such that the corresponding facets F_{r_i} have linearly independent normal vectors.

For two sets C^1 and C^2 in \mathbb{T}^d with disjoint closure, let $N(C^1, C^2) \in \mathbb{N}$ be the minimal number such that there exist $n_1 \leq n_2 \leq \dots \leq n_K \leq N(C^1, C^2)$ separating C_1 and C_2 .

Definition 3.1.5 We call $\Theta(P)$ the separating diameter of P . For sets C^1 and C^2 in \mathbb{T}^d with disjoint closure and with $\text{diam}(C^i) < \theta$, $i = 1, 2$, and $\theta < \Theta(P)$, we call $N(C^1, C^2) \in \mathbb{N}$ the separation number of C^1 and C^2 .

Remark 3.1.6 The concept of the separation number presented here is related to the connectedness index introduced in [2].

3.1.6 The projection body

For a presentation of the theory of convex geometry we refer to [36].

Let $K \subseteq \mathbb{R}^d$ be a bounded convex set. Then the function

$$h_K : S_{d-1} \rightarrow \mathbb{R}, \quad h_K(u) = \sup\{x \cdot u : x \in K\}$$

is called support function. h_K determines K . Denote, for $u \in S_{d-1}$, by $K|_u$ the projection of K onto the hyperplane $H_{u,0}$. Then each convex body K determines the convex body ΠK whose support function is

$$h_{\Pi K}(u) = \lambda^{d-1}(K|_u).$$

ΠK , called projection body of K , is a very well understood object in convex geometry. The following equation holds

$$\lambda^d(\Pi K) = \frac{1}{d!} \int_{S_{d-1}} \dots \int_{S_{d-1}} |\text{Det}(u_1, \dots, u_d)| d\rho(v) \dots d\rho(v),$$

where the ρ_i are the so called generating measures of ΠK . If $K = P$ is a polytope, these generating measures are concentrated on the normal vectors of the facets.

3.2 Main result

Theorem 3.2.1 *Let P be a polytope in \mathbb{T}^d with L facets F_r and normal vectors u_r , $r = 1, \dots, L$. Let $\alpha \in \mathbb{T}^d$ be strongly irrational. Let P and α be σ' -a.i. Then*

$$\mathcal{P}(P, \alpha) = \mathcal{P}(d, P, \alpha) = \lim_{N \rightarrow \infty} \frac{P_{P, \alpha}(N)}{N^d} = \frac{1}{d!} \sum_{r_1=1}^L \dots \sum_{r_d=1}^L \left(|\text{Det}(u_{r_1}, \dots, u_{r_d})| \prod_{j=1}^d \lambda^{d-1}(F_{r_j}) \right).$$

In particular, if P is a convex polytope in \mathbb{T}^d , then

$$\mathcal{P}(P, \alpha) = \lambda^d(\Pi P),$$

where ΠP denotes the projection body of P .

Remark 3.2.2 In [37] results related to our Theorem 3.2.1 were obtained in the context of stochastic geometry.

The main tool of the proof is the following estimate for the local complexity $P(C, N)$ induced by P and α .

Proposition 3.2.3 *Let P be a polytope in \mathbb{T}^d with L facets F_r and normal vectors u_r , $r = 1, \dots, L$. Let $\alpha \in \mathbb{T}^d$ be strongly irrational. Let P and α be σ' -a. i. Let $C = C(\sigma, x)$ be an arbitrary cube with side length $\sigma > 0$ and center x , where σ is chosen small enough to ensure that $\xi(P)\sigma < \sigma'$. Then*

$$\begin{aligned} & \frac{\sigma^d}{d!} \left(\sum_{r_1=1}^L \dots \sum_{r_d=1}^L \left(|\text{Det}(u_{r_1}, \dots, u_{r_d})| \prod_{j=1}^d \lambda^{d-1}(F_{r_j}^{-\xi(P)\sigma}) \right) \right) \\ & \leq \lim_{N \rightarrow \infty} \frac{P(C, N)}{N^d} \\ & \leq \frac{\sigma^d}{d!} \left(\sum_{r_1=1}^L \dots \sum_{r_d=1}^L \left(|\text{Det}(u_{r_1}, \dots, u_{r_d})| \prod_{j=1}^d \lambda^{d-1}(F_{r_j}^{+\xi(P)\sigma}) \right) \right). \end{aligned}$$

To deduce Theorem 3.2.1 from Proposition 3.2.3 we proceed as in the proof of Theorem 2.1.1.

Proof of Theorem 3.2.1: For $k \in \mathbb{N}$, $k > 1/\sigma'$, let $\sigma = 1/k$ and cover \mathbb{T}^d

by k^d disjoint cubes $C_i(1/k) := (x_i - 1/(2k), x_i + 1/(2k)]^d$. Let $\varepsilon > 0$. Let $\Theta(P)$ be the separating diameter of P and choose k large enough such that $1/(k-1) < \Theta(P)$.

By Lemma 3.1.4, for two disjoint cubes $C_i^{-\varepsilon} = C_i(1/k - \varepsilon)$ and $C_j^{-\varepsilon} = C_j(1/k - \varepsilon)$, $i \neq j$, there exists a separation number $N(C_i, C_j)$. Observe that $N \geq N(C_i, C_j)$ implies that $W(C_i, P, N) \cap W(C_j, P, N) = \emptyset$.

Thus, considering the local complexities of all cubes $C_i^{-\varepsilon}$, $i = 1, \dots, k^d$, simultaneously, Proposition 3.2.3 implies as a lower bound for the asymptotic complexity

$$\liminf_{N \rightarrow \infty} \frac{P_{P,\alpha}(N)}{N^d} \geq \frac{k^d(1/k - \varepsilon)^d}{d!} \left(\sum_{i_1=1}^L \dots \sum_{i_d=1}^L \left(|\text{Det}(u_{i_1}, \dots, u_{i_d})| \prod_{j=1}^d \lambda^{d-1}(F_{i_j}^{-c(1/k-\varepsilon)}) \right) \right).$$

This holds for all $\varepsilon > 0$. Therefore we have

$$\begin{aligned} \liminf_{N \rightarrow \infty} \frac{P_{P,\alpha}(N)}{N^d} &\geq \frac{k^d(1/k)^d}{d!} \left(\sum_{i_1=1}^L \dots \sum_{i_d=1}^L \left(|\text{Det}(u_{i_1}, \dots, u_{i_d})| \prod_{j=1}^d \lambda^{d-1}(F_{i_j}^{-c(1/k)}) \right) \right) \\ &= \frac{1}{d!} \sum_{i_1=1}^L \dots \sum_{i_d=1}^L \left(|\text{Det}(u_{i_1}, \dots, u_{i_d})| \prod_{j=1}^d \lambda^{d-1}(F_{i_j}^{-c(1/k)}) \right). \end{aligned}$$

Analogously Proposition 3.2.3 gives the upper bound

$$\begin{aligned} \limsup_{N \rightarrow \infty} \frac{P_{P,\alpha}(N)}{N^d} &\leq \frac{k^d(1/k)^d}{d!} \left(\sum_{i_1=1}^L \dots \sum_{i_d=1}^L \left(|\text{Det}(u_{i_1}, \dots, u_{i_d})| \prod_{j=1}^d \lambda^{d-1}(F_{i_j}^{+c(1/k)}) \right) \right) \\ &= \frac{1}{d!} \sum_{i_1=1}^L \dots \sum_{i_d=1}^L \left(|\text{Det}(u_{i_1}, \dots, u_{i_d})| \prod_{j=1}^d \lambda^{d-1}(F_{i_j}^{+c(1/k)}) \right). \end{aligned}$$

Both bounds work for all $k \in \mathbb{N}$ with $k > 1/\sigma'$. But $\lambda^{d-1}(F_i^{+c(1/k)}) - \lambda^{d-1}(F_i)$ and $\lambda^{d-1}(F_i) - \lambda^{d-1}(F_i^{-c(1/k)})$ tend to zero for $k \rightarrow \infty$ for all $i \in$

$\{1, \dots, L\}$. Thus, for every $\delta > 0$ there exists a $k \in \mathbb{N}$ such that

$$\left| \frac{1}{d!} \sum_{i_1=1}^L \dots \sum_{i_d=1}^L \left(|\text{Det}(u_{i_1}, \dots, u_{i_d})| \prod_{j=1}^d \lambda^{d-1}(F_{i_j}^{+c(1/k)}) \right) - \frac{1}{d!} \sum_{i_1=1}^L \dots \sum_{i_d=1}^L \left(|\text{Det}(u_{i_1}, \dots, u_{i_d})| \prod_{j=1}^d \lambda^{d-1}(F_{i_j}^{-c(1/k)}) \right) \right| \leq \delta.$$

Hence we also have $\left| \limsup_{N \rightarrow \infty} \frac{P_{P,\alpha}(N)}{N^d} - \liminf_{N \rightarrow \infty} \frac{P_{P,\alpha}(N)}{N^d} \right| \leq \delta$ for every $\delta > 0$. \blacksquare

3.3 Proof of Proposition 3.2.3

3.3.1 Overview

To prove Proposition 3.2.3 we must, assuming σ' -a.i., find an appropriate lower and upper bound for the local complexity, $P(C, N)$, of the cube $C = C(\sigma, x) \subseteq \mathbb{T}^d$ induced by the fixed polytope $P \subseteq \mathbb{T}^d$ with L facets $F_r \subseteq H_{u_r, \lambda_r}$, $r = 1, \dots, L$, in $[0, 1]^d$ and a strongly irrational $\alpha \in \mathbb{T}^d$. In Section 3.1.2 we introduced the local complexity

$$P(C, N) = \left| \left\{ P_w = \bigcap_{j=0}^{N-1} C \cap (P^{a_{k+j}} - j\alpha), \right\} \right|,$$

for $w = a_k a_{k+1} \dots a_{k+N-1} \in W(C, N)$, $P^1 := P$ and $P^0 := \mathbb{T}^d \setminus P$. The local complexity of a cube C coincides with the number of partition cells in C . Denote by $\widehat{\Pi}(C, N)$ the set of all such partition cells in C , corresponding to words of length N . Then $P(C, N) = |\widehat{\Pi}(C, N)|$. For $w = a_k a_{k+1} \dots a_{k+N-1} \in W(C, N)$, each partition cell is given by

$$P_w = \bigcap_{j=0}^{N-1} (C \cap (P^{a_{k+j}} - j\alpha)) \tag{3.1}$$

$$= \bigcap_{j=0}^{N-1} (((C + j\alpha) \cap P^{a_{k+j}}) - j\alpha). \tag{3.2}$$

(3.1) points out that the partition cells are determined by the preimages of P . (3.2) indicates that $P(C, N)$ depends on the partition of C by ∂P when being translated by α . We will use both approaches in the sequel.

In order to estimate the cardinality of $\widehat{\Pi}(C, N)$ we shall construct two partitions $\Pi^1(C, N)$ and $\Pi^2(C, N)$ of C induced by certain sequences of hyperplanes and with the property

$$|\Pi^1(C, N)| \leq |\widehat{\Pi}(C, N)| \leq |\Pi^2(C, N)|.$$

The advantage of partitions induced by hyperplanes is the fact that the number of vertices, i.e. intersection points of d -hyperplanes with linearly independent normal vectors, and the number of d -dimensional partition cells are essentially the same.

A general result in this direction follows in Section 3.3.2. In Section 3.3.3, we define sequences of hyperplanes yielding the partitions $\Pi^i(C, N)$, $i = 1, 2$. For these hyperplanes, we combine in Section 3.3.4 the σ' -a.i. and Lemma 3.3.3 to show that the number of partition cells indeed coincides asymptotically with the number of vertices. Using this, the mapping A_w , and the equidistribution property of the sequence $(n\alpha)_{n \geq 0}$ in \mathbb{T} , we are able to compute an explicit formula in 3.3.5. Summing up, we finish the proof of Proposition 3.2.3 in Section 3.3.6.

3.3.2 A basic lemma

Let \mathbb{R}^d be the d -dimensional Euclidean space. Let $C \subseteq \mathbb{R}^d$ be a d' -dimensional, $d' \leq d$, bounded convex set. Let $(H_i)_{i=1}^\infty$ denote a sequence of hyperplanes in \mathbb{R}^d .

The hyperplanes $(H_i)_{i=1}^M$ induce a partition in C . It is natural to assume some relation between the d' -dimensional partition cells and the vertices, i.e. those $x \in C$ with $\{x\} = \bigcap_{j=1}^{d'} H_{i_j}$, for suitable $i_j \in \{1, \dots, M\}$. To establish such a relation we introduce the concept of the weight.

For every point $x \in C$ we define a weight $w(x, M, C) \in \mathbb{N}$ recursively on M , the number of hyperplanes $(H_i)_{i=1}^M$, and d' , $1 \leq d' \leq d$, the dimension of C , in the following way:

1. $w(x, 0, C) = 0$ for all d' -dimensional C , $d' \in \{1, \dots, d\}$, and for all $x \in C$.
2. If $d' = 1$, set

$$w(x, M, C) = \begin{cases} 1 & \text{if } \{x\} = H_i \cap C^\circ \text{ for some} \\ & i \in \{1, 2, \dots, M\}, \\ 0 & \text{otherwise.} \end{cases}$$

Here C° denotes the interior of C w.r.t. the 1-dimensional topology.

3. Assume, $w(x, M', C')$ is defined for every d'' -dimensional C' , $1 \leq d'' < d'$ and every $1 \leq M' < M$. Let C be d' -dimensional. Let $C_M := C \cap H_M$. Then set

$$w(x, M, C) = \begin{cases} w(x, M-1, C) & \text{if } x \in H_M \cap C^\circ, C \not\subseteq H_M \\ +w(x, M-1, C_M) & \text{and } C_M \neq H_i \cap C \\ & \text{for all } 1 \leq i < M, \\ w(x, M-1, C) & \text{otherwise.} \end{cases}$$

Again, C° denotes the interior of C w.r.t. the d' -dimensional topology.

Note that points 2 and 3 yield the following implication.

$$C \subseteq H_M \text{ or } C \cap H_M = \emptyset \implies w(x, M, C) = w(x, M-1, C). \quad (3.3)$$

Moreover, $w(x, M, C) = 0$ for all $x \in \partial C$ and all d' -dimensional C , all $M \in \mathbb{N}$.

Remark 3.3.1 Observe that $w(x, M, C) > 0$ if and only if $x \in C$ is an intersection point of at least d' hyperplanes not containing C and with linearly independent normal vectors. More precisely, let $\{x\} = \bigcap_{j=1}^{d'} H_{i_j}$ for suitable $i_j \in \{1, \dots, M\}$. The inductive definition of the weight guarantees that

$$w(x, M, C) \begin{cases} = 1 & \text{if } x \text{ is contained in exactly } d' \text{ distinct hyperplanes,} \\ > 1 & \text{if } x \text{ is contained in more than } d' \text{ distinct hyperplanes.} \end{cases} \quad (3.4)$$

Moreover, the definition allows to show the following assertion

Lemma 3.3.2 *Let C be d' -dimensional. Let $L \geq d'$ be the number of hyperplanes intersecting C and containing $x \in C$. Then*

$$w(x, M, C) = \begin{cases} 1 & \text{if } d' = 1, \\ \sum_{i_1=1}^{L-d'} \sum_{i_2=1}^{i_1} \cdots \sum_{i_{d'}=1}^{i_{d'-1}} 1 =: C(L, d') & \text{if } d' > 1. \end{cases} \quad (3.5)$$

Proof: Via induction on L and d' :

$d' = 1, L = 1$ and $d' = 1, L - 1 \rightarrow L$: Clear.

$d' - 1 \rightarrow d'$ and $L = d'$: Clear.

$d' - 1 \rightarrow d'$ and $L - 1 \rightarrow L$: By induction hypothesis we can assume for a d'' -dimensional C'

$$\begin{aligned} w(x, M - 1, C') &\leq C(L', d'') \quad \text{for any } L' \in \mathbb{N} \text{ and any } d'' < d', \text{ and} \\ w(x, M - 1, C') &\leq C(L', d'') \quad \text{for } d'' = d' \text{ and any } L' \leq L - 1. \end{aligned}$$

Assume now, to finish the inductive proof, $d'' = d', L' = L - 1$ and $x \in H_M$, i.e. $L - 1 \rightarrow L$. But then, according to the definition of the weight,

$$\begin{aligned} w(x, M, C') &= w(x, M - 1, C') + w(x, M - 1, C'_M) \\ &\leq \underbrace{\sum_{i_1=1}^{L-1-d'} \sum_{i_2=1}^{i_1} \cdots \sum_{i_{d'}=1}^{i_{d'-1}} 1}_{d'\text{-fold summation}} + \underbrace{\sum_{i_1=1}^{L-1-(d'-1)} \sum_{i_2=1}^{i_1} \cdots \sum_{i_{(d'-1)}=1}^{i_{(d-1)-1}} 1}_{(d'-1)\text{-fold summation}} \\ &= C(L, d'). \end{aligned}$$

The last equality holds since the last $(d' - 1)$ -fold summation in the previous line is the missing last summand of the d' -fold summation. \blacksquare

Let $G(C, M) := \{x \in C : w(x, M, C) \geq 1\}$ be the set of all such intersection points in C after M hyperplanes. $G(C, M)$ is a discrete, finite set for all $M \in \mathbb{N}$.

The intersections of C by $H_i, i = 1, \dots, M$, induce a partition of C . Let $\Pi_{d'}(C, M)$ be the set of all d' -dimensional partition cells in C after M intersections. In particular an element $\pi \in \Pi_{d'}(C, M)$ is called an inner partition cell, if $\bar{\pi} \cap \partial C = \emptyset$. Let $\Pi_{d'}(C, M)^\circ$ be the set of all d' -dimensional inner partition cells.

Lemma 3.3.3 *Let $d' \in \{1, \dots, d\}$. Let C be a d' -dimensional bounded convex set. Let $M \in \mathbb{N}$. Then*

$$|\Pi_{d'}(C, M)^{\circ}| \leq \sum_{x \in G(C, M)} w(x, M, C) \leq |\Pi_{d'}(C, M)|.$$

Proof: We prove the statement by induction. Under the assumption $C_M := H_M \cap C \neq \emptyset$, $C_M \neq H_i \cap C$ for all $i = 1, \dots, M-1$ and $C \not\subseteq H_M$ we first verify the equations

$$|\Pi_{d'}(C, M)| = |\Pi_{d'}(C, M-1)| + |\Pi_{d'-1}(C_M, M-1)|, \quad (3.6)$$

$$|\Pi_{d'}(C, M)^{\circ}| \leq |\Pi_{d'}(C, M-1)^{\circ}| + |\Pi_{d'-1}(C_M, M-1)^{\circ}|. \quad (3.7)$$

To see this, note that each partition cell itself is a convex set in C . Let $\pi \in \Pi_{d'}(C, M-1)$. Then $\pi^{\circ} \cap H_M \neq \emptyset$ (π° denotes the interior of π w.r.t. the d' -dimensional topology) is equivalent to the fact that in the M -th intersection π is split into two partition cells $\pi_1 = \pi \cap H_M^-$ and $\pi_2 = \pi \cap H_M^+ \in \Pi_{d'}(C, M)$. $\pi \cap H_M$ is the $(d'-1)$ -dimensional set in C_M separating π_1 and π_2 . This holds for any partition cell π . Hence observe that the number of additional cells induced by H_M equals the number of $(d-1)$ -dimensional cells in C_M proving (3.6). The same argument applies to (3.7). But since each splitting set in $\Pi_{d'-1}(C_M, M-1)^{\circ}$ does not necessarily generate a new inner partition cell we only obtain an inequality.

We prove the assertion by a twofold induction on the dimension d' and the number of intersections M .

$d' = 1$, $M \in \mathbb{N}$ and $d' - 1 \rightarrow d'$, $M = 0$: Clear by definition of $w(x, M, C)$.

$d' - 1 \rightarrow d'$, $M - 1 \rightarrow M$:

Case 1: $C_M := H_M \cap C \neq \emptyset$, $C_M \neq H_i \cap C$ for all $i = 1, \dots, M-1$ and $C \not\subseteq H_M$. Using, (3.6), (3.7), and the induction hypothesis, we obtain

$$\begin{aligned} |\Pi_{d'}(C, M)^{\circ}| &\leq |\Pi_{d'}(C, M-1)^{\circ}| + |\Pi_{d'-1}(C_M, M-1)^{\circ}| \\ &\leq \underbrace{\sum_{x \in G(C, M-1)} w(x, M-1, C) + \sum_{x \in G(C_M, M-1)} w(x, M-1, C_M)}_{= \sum_{x \in G(C, M)} w(x, M, C) \text{ by definition}} \\ &\leq |\Pi_{d'}(C, M-1)| + |\Pi_{d'-1}(C_M, M-1)| = |\Pi_{d'}(C, M)|. \end{aligned}$$

Case 2: $C_M := H_M \cap C = \emptyset$, or $C_M = H_i \cap C$ for a number $i \in \{1, \dots, M-1\}$, or $C \subseteq H_M$. Then $|\Pi_{d'}(C, M)| = |\Pi_{d'}(C, M-1)|$ and $|\Pi_{d'}(C, M)^{\circ}| =$

$|\Pi_{d'}(C, M - 1)^o|$. Hence, by the induction hypothesis on M ,

$$\begin{aligned} |\Pi_{d'}(C, M)^o| &= |\Pi_{d'}(C, M - 1)^o| \\ &\leq \sum_{x \in G(C, M-1)} w(x, M - 1, C) \\ &\leq |\Pi_{d'}(C, M - 1)| = |\Pi_{d'}(C, M)|. \end{aligned}$$

Under the assumptions in Case 2, the definition of the weight guarantees

$$\sum_{x \in G(C, M-1)} w(x, M - 1, C) = \sum_{x \in G(C, M)} w(x, M, C).$$

■

3.3.3 Coverings of the boundary of $P \subseteq \mathbb{T}^d$ and hyperplanes intersecting C

Let P be an arbitrary polytope in $[0, 1]^d$ with facets $F_r \subseteq H_{u_r, \lambda_r}$, $r = 1, \dots, L$, and x.t.-constant $\xi(P)$. Let $\sigma > 0$ such that $\xi(P)\sigma < \sigma'$. Let $B_0 = B_{\xi(P)\sigma}$ and let E be a parallelepiped in $[0, 1]^d$ with center e . Let $E' = E - e$ be the translate of E with center 0. Let, for $r \in \{1, 2, \dots, L\}$,

$$\begin{aligned} \phi_r(\sigma) &= F_r \setminus \left(\bigcup_{j=1, j \neq r}^d (F_j + B_0) \right), \\ \Phi_r(\sigma) &= F_r^{\sigma'} \cap (F_r + B_0), \\ J_r(E) &= \{ \lambda \in \mathbb{R} : H_{u_r, \lambda} \cap E' \neq \emptyset \}, \\ \gamma_r(E) &= \{ z \in [0, 1]^d : z = y + \lambda u_r, y \in \phi_r(\sigma), \lambda \in J_r(E) \}, \\ \Gamma_r(E) &= \{ z \in [0, 1]^d : z = y + \lambda u_r, y \in \Phi_r(\sigma), \lambda \in J_r(E) \}, \\ \gamma(E) &= \bigcup_{r=1}^L \gamma_r(E), \quad \Gamma(E) = \bigcup_{r=1}^L \Gamma_r(E). \end{aligned}$$

Thus, for $r = 1, \dots, L$, ϕ_r and Φ_r are subsets of the enlarged facet $F_r^{\sigma'}$. Translates of ϕ_r are two facets of the rectangular parallelepiped $\gamma_r(E)$ in $[0, 1]^d$, which covers (partly) the facet F_r . The height of both, $\gamma_r(E)$ and $\Gamma_r(E)$, equals the length of the interval $J_r(E)$. The Figures 3.3 and 3.4 illustrate these definitions.

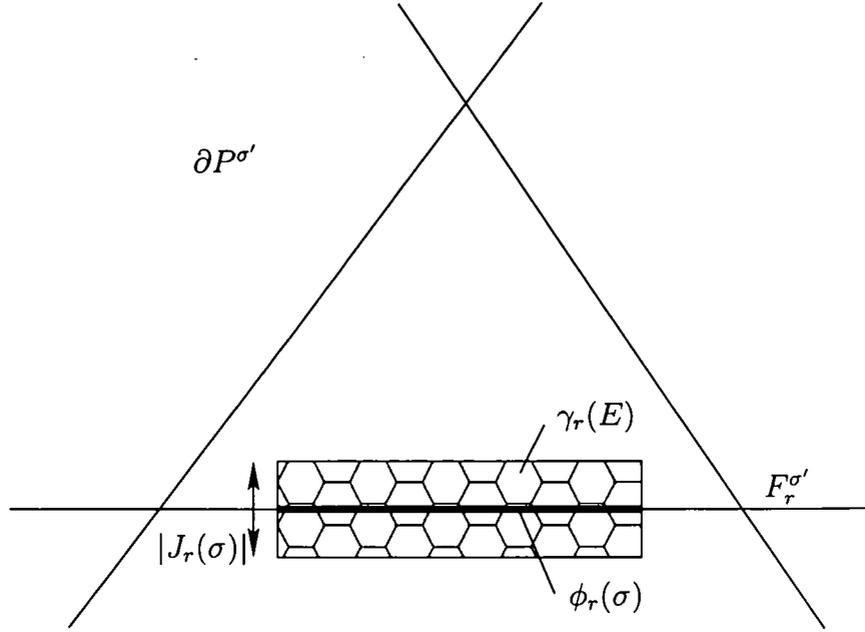

Figure 3.3: Partial covering of F_r by $\gamma_r(E)$

We interpret $\gamma_r(E)$ and $\Gamma_r(E)$ again as subsets of \mathbb{T}^d . Let, for $r \in \{1, 2, \dots, L\}$,

$$N_r^i(E) = \left\{ n \in \mathbb{N} : n\alpha + d \in \begin{array}{ll} \gamma_r(E) & \text{if } i = 1 \\ \Gamma_r(E) & \text{if } i = 2 \end{array} \right\},$$

$$N^i(E) = \bigcup_{r=1}^L N_r^i(E).$$

Each $n \in N^i(E)$ corresponds to some hyperplanes $H_{u,\lambda} = H_{u_r,\lambda}^{(n)} \subseteq \mathbb{R}^d$ for which there exists an $r \in \{1, \dots, L\}$ such that

$$(H_{u,\lambda} \cap E) + n\alpha \subseteq F_r^{\sigma'}. \quad (3.8)$$

Remark 3.3.4 Note that $\frac{n \in N^1(E)}{n \in N^2(E)}$ implies that (3.8) holds for ^{exactly one} _{some} $r \in \{1, \dots, L\}$.

Let \prec be the lexicographical order on $\mathbb{N} \times \{1, 2, \dots, L\}$, i.e. $(n, r) \prec (n', r')$ iff $n \leq n'$ or $n = n'$ and $r \leq r'$.

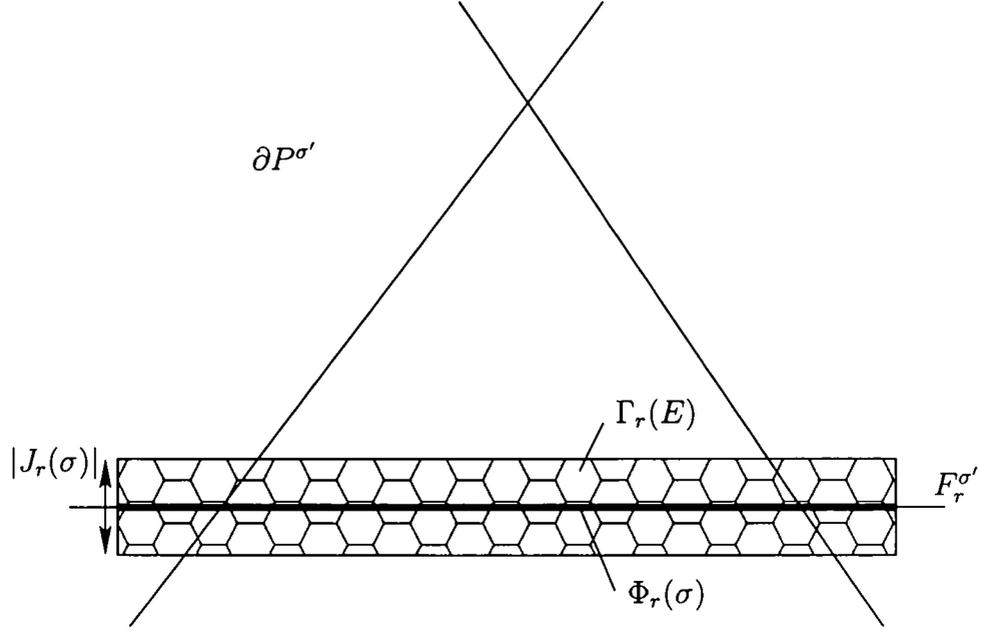

Figure 3.4: Covering of F_r by $\Gamma_r(E)$

Let $\mathcal{H}^i(E)$ denote the set of hyperplanes $H_{u_r, \lambda}^{(n)} \subseteq \mathbb{R}^d$ with $n \in N^i(E)$. We can order its elements according to $<$ by setting $H_{u_r, \lambda}^{(n)} < H_{u_{r'}, \lambda'}^{(n')}$ if $(n, r) < (n', r')$. Let $(H_j^i(E))_{j \geq 0}$, $i = 1, 2$, be the resulting sequence containing all elements of $\mathcal{H}^i(E)$ ordered increasingly.

Further, we define $\mathcal{H}^i(E, N)$, $i = 1, 2$, to be the set containing all $H_{u_r, \lambda}^{(n)} \in \mathcal{H}^i(E)$ with $n < N$. Finally let, for $W \subseteq \{u_1, u_2, \dots, u_L\}$, $\mathcal{H}^i(E, N, W)$, $i = 1, 2$, denote the set containing all $H_{u_r, \lambda}^{(n)} \in \mathcal{H}^i(E)$ with $n < N$ and with $u_r \in W$.

The hyperplanes $H_j \in \mathcal{H}^i(E, N)$, $i = 1, 2$, induce partitions of E . The partition cells are given by

$$|\mathcal{H}^i(E, N)| \bigcap_{j=1} H_j^\pm.$$

Let $\Pi^i(E, N)$, $i = 1, 2$, denote the set of all such partition cells induced by

the elements of $\mathcal{H}^i(E, N)$.

The elements of $\mathcal{H}^i(C, N)$, $i = 1, 2$, are defined in such a way that the partitions $\Pi^i(E, N)$, $i = 1, 2$, can be used for the estimate of the local complexity $P(C, N)$ as we announced in Section 3.3.1.

Lemma 3.3.5 *Let $C = C(\sigma, x)$. Then*

$$|\Pi^1(C, N)| \leq P(C, N) \leq |\Pi^2(C, N)|.$$

Proof: According to the definition of the elements of $\mathcal{H}^i(C, N)$, $i = 1, 2$, the partition $\frac{\Pi^1(C, N)}{\Pi^2(C, N)}$ is induced by intersections of C with $\frac{\phi_r(\sigma)}{\Phi_r(\sigma)}$, for $r = 1, 2, \dots, L$ and $\phi_r(\sigma) \subseteq F_r \subseteq \Phi_r(\sigma)$, for all $r \in \{1, 2, \dots, L\}$. Moreover, $x + n\alpha \in \gamma_r(\sigma)$ implies that $C + n\alpha$ is partitioned by F_r in (exactly) two connected partition cells. These properties guarantee that we can use $|\Pi^1(C, N)|$ ($|\Pi^2(C, N)|$) as a lower (an upper) bound for the local complexity $P(C, N)$ of C . ■

Motivated by Lemma 3.3.5 we focus on the estimate of $|\Pi^i(E, N)|$, $i = 1, 2$. Using Lemma 3.3.3 and σ' -a.i. of P and α , we want to establish a connection between $|\Pi^i(E, N)|$, $i = 1, 2$, and the number of so-called intersecting d -tuples, which are defined in the following way.

Let, for $i = 1, 2$, $H_1^i, H_2^i, \dots, H_M^i$ be the increasingly ordered elements of $\mathcal{H}^i(E, N)$. Let $W \subseteq \{u_1, u_2, \dots, u_L\}$. Define

$$\begin{aligned} V^i(E, N) &= \left\{ (j_1, \dots, j_d) : \begin{array}{l} j_1 < j_2 < \dots < j_d, \\ \exists x \in E \text{ with } \{x\} = \bigcap_{k=1}^d H_{j_k}^i \end{array} \right\}, \\ V^i(E, N, W) &= \left\{ (j_1, \dots, j_d) : \begin{array}{l} j_1 < j_2 < \dots < j_d, \\ \exists x \in E \text{ with } \{x\} = \bigcap_{k=1}^d H_{j_k}^i \\ \text{and } H_{j_k}^i \in \mathcal{H}^i(E, N, W) \end{array} \right\}, \\ V_0^i(E, N) &= \left\{ (j_1, \dots, j_d) \in V^i(E, N) : \begin{array}{l} \bigcap_{k=1}^d H_{j_k} \not\subseteq H_{j'}^i, \text{ for all } \\ H_{j'}^i \in \mathcal{H}^i(E, N) \setminus \\ \{H_{j_k} : 1 \leq k \leq d\} \end{array} \right\}. \end{aligned}$$

$V^i(E, N)$ can be interpreted as the set of all vertices in E induced by elements of $\mathcal{H}^i(E, N)$ (a vertex $x \in E$ is an intersection point of d elements of $\mathcal{H}^i(E, N)$ with linearly independent normal vectors). Thus, we call its elements intersecting d -tuples (i.d.-tuples). Accordingly, $V_0^i(E, N)$ represents the set of all vertices that are elements of exactly d hyperplanes

with linearly independent normal vectors in $\mathcal{H}^i(E, N)$. It is natural to call its elements uniquely intersecting d -tuples (u.i.d-tuples). Obviously $V_0^i(E, N) \subseteq V^i(E, N)$.

We conclude this section with an assertion which describes the distribution of the hyperplanes $\mathcal{H}^i(E)$, $i = 1, 2$, intersecting E . For this reason, let $\mathcal{H}^i(E, w)$, $i = 1, 2$, denote the set of all hyperplanes in $\mathcal{H}^i(E)$, $i = 1, 2$, with normal vector $w \in S_{d-1}$.

Lemma 3.3.6 *Let P be a polytope in $[0, 1]^d$ with facets $F_r \subseteq H_{u_r, \lambda_r}$, $r = 1, \dots, L$. Fix $r \in \{1, 2, \dots, L\}$. Then the sequence $(\mu_j - \lambda_r)_{j \geq 1}$, induced by $H_i = H_{v_j, \mu_j} \in \mathcal{H}^i(E, u_r)$, $i = 1, 2$, ordered increasingly w.r.t. \prec , is uniformly distributed in the interval $J_w(E)$ in the sense that for any subinterval $I \subseteq J_r(E)$,*

$$\lim_{J \rightarrow \infty} \frac{|\{\mu_j \in I : 1 \leq j \leq J\}|}{J} = \begin{cases} |I| \lambda^{d-1}(\phi_r(\sigma)) & \text{if } i = 1, \\ |I| \lambda^{d-1}(\Phi_r(\sigma)) & \text{if } i = 2. \end{cases} \quad (3.9)$$

Proof: This assertion follows from the fact that the sets $\gamma_r(E)$ and $\Gamma_r(E)$ are, by construction, rectangular parallelepipeds as well as from the equidistribution property of the sequence $(n\alpha)_{n=1}^\infty$. ■

3.3.4 Consequences of Lemma 3.3.3 and σ' -asymptotic independence

Let $P \subseteq [0, 1]^d$ be a closed polytope with L facets $F_i \subseteq H_{u_r, \lambda_r}$, $r = 1, \dots, L$, interpreted as a polytope in \mathbb{T}^d . Let $\alpha \in \mathbb{T}^d$ be strongly irrational such that P and α are σ' -asymptotically independent, with suitable $\sigma' > 0$. Let $\sigma > 0$ so that $\xi(P)\sigma \leq \sigma'$. Let $C = C(\sigma, x)$ be a fixed cube.

Following Sections 3.3.1 and 3.3.2, let $\mathcal{H}^i(C, N)$, $i = 1, 2$, be as above, with the elements $(H_j)_{j=1}^{|\mathcal{H}^i(C, N)|}$, $i = 1, 2$.

We will show how σ' -a.i. and Lemma 3.3.3 imply that the number of partition sets in C induced by the elements of $\mathcal{H}^i(C, N)$, $i = 1, 2$, can be estimated by the number of elements of $V^i(C, N)$, $i = 1, 2$.

In the sequel we will omit the superscript i whenever we do not need to distinguish between the cases $i = 1$ and $i = 2$. Assume C is partitioned by the halfspaces induced by the elements of $\mathcal{H}(C, N)$. As before let, for $d' \in \{1, \dots, d\}$, $\Pi_{d'}(C, N)$ denote the set of all d' dimensional partition sets in $\Pi(C, N)$. We write abbreviating $w(x, N, C)$ for $w(x, |\mathcal{H}(C, N)|, C)$, the weight of a point x in C as defined in the previous section and $G(C, N) = \{x \in C : w(x, N, C) \geq 1\}$.

We show that, due to σ' -a.i., $V(C, N) \setminus V_0(C, N)$ is small. To do so, we first count the over-determined vertices in \mathbb{T}^d after N -fold translation of $\partial P^{\sigma'}$ by α if P and α are σ' -a.i.

For this reason, let

$$U(N) := \left\{ x \in \mathbb{T}^d : \begin{array}{l} \exists r_1, r_2, \dots, r_d \in \{1, \dots, L\}, \\ \exists n_1, n_2, \dots, n_d \in \{0, \dots, N-1\} \\ \text{such that } \{x\} = \bigcap_{j=1}^d F_{r_j}^{\sigma'} - n_j \alpha \end{array} \right\}$$

be the set of all vertices $x \in \mathbb{T}^d$ after N -fold translation. Let, for $x \in \mathbb{T}^d$,

$$I(x, N) := \{(n, r) \in \{0, \dots, N-1\} \times \{1, \dots, L\} : x \in F_r^{\sigma'} - n\alpha\}.$$

assign to each x the set of translates of facets which contain x .

Lemma 3.3.7 *Let P and α be σ' -a.i. Then*

$$|\{x \in U(N) : |I(x, N)| > d\}| = o(N^d).$$

Proof: Let $x \in U(N)$ with $|I(x, N)| = e > d$. Let

$$I(x, N) = \{(n_1, r_1), (n_2, r_2), \dots, (n_e, r_e)\}$$

and assume $n_1 \leq n_2 \leq \dots \leq n_e$. Then

$$I(x + n_1, N) = \{(0, r_1), (n_2 - n_1, r_2), \dots, (n_e - n_1, r_e)\}.$$

and $x \in \partial P^{\sigma'}$. For an arbitrary $x \in \mathbb{T}^d$, let

$$\text{lev}(x) = \min \{n \in \mathbb{N} : \exists r \in \{1, \dots, L\} \text{ such that } (n, r) \in I(x, N)\}.$$

For each $x \in U(N)$ with $|I(x, N)| > d$, there is a $x_0 = x + \text{lev}(x)\alpha \in \partial P^{\sigma'}$ with $|I(x_0, N)| > d$. By σ' -a.i., on each enlarged facet $F_i^{\sigma'}$ of $\partial P^{\sigma'}$ there are at most $o(N^{d-1})$ points x_0 with $x_0 \in U(N)$ and $|I(x_0, N)| > d$. Hence, also on $\partial P^{\sigma'}$ there are at most $o(N^{d-1})$ points x_0 with $x_0 \in U(N)$ and $|I(x_0, N)| > d$. Therefore, for every $n \in \mathbb{N}$, there are $o(N^{d-1})$ points x with $\text{lev}(x) = n$, $x \in U(N)$ and $|I(x, N)| > d$. Summing up, there are at most $o(N^{d-1})$ points $x \in U(N)$ and $|I(x, N)| > d$. \blacksquare

Lemma 3.3.8 *Let P and α be σ' -a.i. Then*

$$|V(C, N)| = |V_0(C, N)| + o(N^d).$$

Proof: Note that $V(C, N) \setminus V_0(C, N)$ corresponds to those points $x \in C$ with $x \in U(N)$ and $|I(x, N)| > d$. But by Lemma 3.3.7 there are at most $o(N^d)$ such points in \mathbb{T}^d and hence also in C . Moreover, σ' -a.i. implies that each x is contained in at most L hyperplanes (cf. condition 2. of Definition 3.1.2). Hence, each point $x \in U(N)$ with $|I(x, N)| > d$ implies at most $\binom{L}{d}$ d -tuples which are elements of $V(C, N) \setminus V_0(C, N)$. \blacksquare

The following lemma connects $|V_0(C, N)|$ and the weight function.

Lemma 3.3.9 *Let P and α be a.i. Then*

$$|V_0(C, N)| = \sum_{x \in G(C, N)} w(x, N, C) + o(N^d).$$

Proof: It follows from the inductive definition of the weight function that an $x \in C$ is an element of $G(C, N)$ iff there exists a d tuple $(j_1, \dots, j_d) \in V(C, N)$ such that $\{x\} = \bigcap_{i=1}^d H_{j_i}$, for $H_{j_i} \in \mathcal{H}(C, N)$. Recall that by Remark 3.3.1, equation (3.4), $w(x, N, C) = 1$ iff there exists a d tuple $(j_1, \dots, j_d) \in V_0(C, N)$ such that $\{x\} = \bigcap_{i=1}^d H_{j_i}$, for $H_{j_i} \in \mathcal{H}(C, N)$. Let $G_0(C, N) = \{x \in G(C, N) : w(x, N, C) = 1\}$. For all $N \in \mathbb{N}$, by σ' -a.i. every x in C is also an element of at most L different hyperplanes in $\mathcal{H}(C, N)$. By Lemma 3.3.2, equation (3.5), $w(x, N, C) \leq C(L, d)$. Hence

$$\begin{aligned} \sum_{x \in G(C, N)} w(x, N, C) &= \\ & \underbrace{\sum_{x \in G_0(C, N)} \underbrace{w(x, N, C)}_{=1}}_{=|V_0(C, N)|} + \underbrace{\sum_{x \in G(C, N) \setminus G_0(C, N)} \underbrace{w(x, N, C)}_{\in \{1, \dots, C(L, d)\}}}_{o(N^d) \text{ summands}}. \end{aligned}$$

■

Let $\varepsilon > 0$ with $\xi(P)(\sigma + \varepsilon) < \sigma'$. If we replace $C = C(\sigma, x)$ by $C^\varepsilon = C(\sigma + \varepsilon, x)$, we can define the sets $\mathcal{H}^i(C^\varepsilon, N)$, $i = 1, 2$, the corresponding induced partitions of C^ε and a corresponding weight function.

Remark 3.3.10 For $S \in \Pi(C^\varepsilon, N)$ let $\text{diam}(S)$ denote its diameter and let $\text{diam}(\Pi(C^\varepsilon, N)) = \sup\{\text{diam}(S) : S \in \Pi(C^\varepsilon, N)\}$. Due to equidistribution, $\text{diam}(\Pi(C^\varepsilon, N)) \rightarrow 0$ as $N \rightarrow \infty$. Thus, for any $\varepsilon > 0$, there exists an N_0 such that $\text{diam}(\Pi(C^\varepsilon, N)) < \varepsilon$ for every $N \geq N_0$.

Lemma 3.3.11 *Let $\varepsilon > 0$. Let N be large enough so that $\text{diam}(\Pi(C^\varepsilon, N)) < \varepsilon$ holds. Then*

$$\sum_{x \in G(C, N)} w(x, N, C) \leq |\Pi_d(C, N)| \leq \sum_{x \in G(C^\varepsilon, N^\varepsilon)} w(x, N^\varepsilon, C^\varepsilon).$$

Proof: The asserted inequality is a direct consequence of Lemma 3.3.3 and $|\Pi_d(C, N)| \leq |\Pi_d(C^\varepsilon, N)^\circ|$. ■

As the next assertion shows, σ' -a.i. implies that it suffices, for asymptotical estimates, to count only the d -dimensional partition sets.

Lemma 3.3.12 *Let $\varepsilon > 0$. Let N be large enough so that $\text{diam}(\Pi(C^\varepsilon, N)) < \varepsilon$ holds. Let P and α be a.i. Then*

$$|\Pi(C, N)| = |\Pi_d(C, N)| + o(N^d).$$

Proof: We show that σ' -a.i. implies $|\Pi_{d'}(C, N)| = o(N^d)$, for all $d' \in \{0, 1, 2, \dots, d-1\}$. Let $d'' = d - d'$.

At first we claim that a set S in $\Pi_{d'}(C, N)$ is necessarily contained in $k > d''$ distinct halfspaces $H_{i_j}^-$, $j = 1, 2, \dots, k$ and $H_{i_j} \in \mathcal{H}(C, N)$.

Note that, for each such $S \in \Pi_{d'}(C, N)$, there exists an $S^1 \subseteq C$ and an $N_1 \in \mathbb{N}$ such that $S \subseteq S^1$, $S^1 \in \Pi_{d_1}(C, N_1 - 1)$, $d_1 \in \{d' + 1, \dots, d\}$ and $H_{N_1}^- \cap S^1 = S$. There are two possibilities:

Case 1: $d_1 = d$: Then $H_{N_1}^-$ cuts S^1 such that $H_{N_1}^- \cap S^1$ is d' -dimensional. By easy linear algebra this is only possible if $H_{N_1}^-$ intersects a d' -dimensional region of the boundary of S^1 which, clearly, is already contained in d'' hyperplanes. This proves the claim if $d_1 = d$.

Case 2: $d_1 < d$: As before, in this case there exists an $S^2 \subseteq C$ and an $N_2 \in \mathbb{N}$ such that $S^1 \subseteq S^2$, $S^2 \in \Pi_{d_2}(C, N_1 - 1)$, $d_2 \in \{d_1 + 1, \dots, d\}$ and $H_{N_2}^- \cap S^2 = S_1$. If $d_2 = d$, then the same argument as in Case 1 proves the claim. If $d_2 < d$, repeat the argument of Case 2. After at most d'' steps we arrive at Case 1.

According to the claim all 0-dimensional partition sets are intersection points of at least $d + 1$ hyperplanes. By σ' -a.i. and Lemma 3.3.7 there are $o(N^d)$ such over-determined intersection points in C . Moreover, the claim and condition 2. of the definition of σ' -a.i. (Definition 3.1.2) imply that there are no $(d - 1)$ -dimensional partition sets. Thus, we can assume $d' \in \{1, \dots, d - 2\}$.

We assign to each d' -dimensional set S the set $J(S) = \{j : S \in H_j\}$ and call $\text{lev}(S) = \min(J(S))$ the level of S .

Let $l \in \mathbb{N}$. We estimate the number of d' -dimensional sets S with $\text{lev}(S) = l$ which lie in more than d'' hyperplanes H_{i_j} , $j = 1, \dots, k$. Observe that each such set S induces the d' -dimensional convex set

$$\text{Cut}(S) = \bigcap_{j=1}^k H_{i_j} \cap C$$

which itself is a subset of H_l . By Lemma 3.3.3, we know that, for $N \in \mathbb{N}$ sufficiently large, an upper bound for the number of d' dimensional sets in $\text{Cut}(S)$ is given by

$$\sum_{x \in G(\text{Cut}(S)^\epsilon, N)} w(x, \text{Cut}(S)^\epsilon, N).$$

(Here, $\text{Cut}(S)^\epsilon := \bigcap_{j=1}^k H_{i_j} \cap C^\epsilon$.) In other words, we can define a bijective mapping

$$\nu : T \mapsto (x(T), t), \quad x \in G(\text{Cut}(S)^\epsilon, N), \quad t \in \{1, 2, \dots, C(L, d'')\}.$$

ν assigns to each d' -dimensional $T \subseteq \text{Cut}(S)$ a point $x(T) \in \text{Cut}(S)$. This works for all sets $\text{Cut}(S')$ with S' in $\Pi_{d'}(C, N)$ of level l .

Let l be a fixed level. Observe that:

(a): By the claim discussed above, all the assigned points $x(T)$ are vertices of C^ε which are contained in more than d intersecting hyperplanes. By condition 1. of the definition of the σ' -a.i., there are at most $o(N^{d-1})$ such vertices in each H_l .

(b): By condition 2. of the definition of the σ' -a.i. each such assigned vertex x can be an element of at most $\binom{L-1}{d'}$ sets $\text{Cut}(S')$.

Combining the statements (a) and (b) implies that there are at most $c(L, d'') \binom{L-1}{d''} o(N^{d-1})$ sets S in $\Pi'_d(C, N)$ of level l . Hence, for any $d' < d$, $\Pi'_d(C, N)$ contains at most $o(N^d)$ elements. ■

The (in-)equalities proven in Lemmata 3.3.8 – 3.3.12 imply the next result.

Proposition 3.3.13 *Let P and α be (σ') -a.i.. Let $\sigma > 0$ and $\varepsilon > 0$ such that $\xi(P)(\sigma + \varepsilon) < \sigma'$. Let $C = C(\sigma, x)$ and $C^\varepsilon = C_x(\sigma + \varepsilon)$ two cubes. Use the notation introduced so far. Then*

$$|V(C, N)| + o(N^d) \leq |\Pi(C, N)| \leq |V(C^\varepsilon, N) + o(N^d)|.$$

For Lemmata 3.3.11 and 3.3.11 we need the assumption that $N \in \mathbb{N}$ is sufficiently large. We remark that in Proposition 3.3.13 this condition is hidden in the term $+o(N^d)$.

Combining the last proposition with Lemma 3.3.5 yields that if P and α are σ' -a.i. one can obtain an asymptotic lower (upper) bound for the local complexity of a cube C by computing the number of intersecting d -tuples generated by the elements of $\mathcal{H}^1(C, N)$ in C ($\mathcal{H}^2(C^\varepsilon, N)$ in C^ε). This computation will be the aim of the following section.

3.3.5 Asymptotic growth rate of the number of intersecting d -tuples induced by $\mathcal{H}^i(D, N, W)$

Let $W = \{w_1, w_2, \dots, w_d\} \subseteq \{u_1, u_2, \dots, u_L\}$. Let A_W be defined as above. Take any $\zeta > 0$ sufficiently small so that $\xi(P)(\zeta + \sigma) < \sigma'$. Let $C^\zeta = C(\sigma + \zeta, x)$ and $C^{-\zeta} = C(\sigma - \zeta, x)$.

Lemma 3.3.14 *For every set $W = \{w_1, w_2, \dots, w_d\} \subseteq \{u_1, u_2, \dots, u_L\}$ and every $\zeta > 0$ holds*

$$|V^1(C, N, W)| + o(N^d) \geq |V^1(A_W(C^{-\zeta}), N, W)| \quad \text{and}$$

$$|V^2(C, N, W)| \leq |V^2(A_W(C), N, W)| + o(N^d).$$

Proof: This follows directly from Lemma 3.3.6 and from the fact that C and $A_W(C)$ are Jordan measurable sets of the same volume. ■

The advantage of considering $A_W(C)$ is that the elements of $W = \{w_1, \dots$

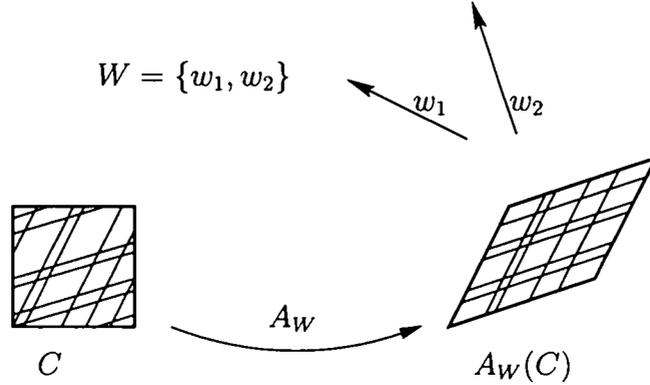

Figure 3.5: The i - d -tuples in C and $A_W(C)$

$\dots, w_d\}$ are exactly the normal vectors of the facets of $A_W(C)$ (cf. Figure 3.5). Due to (σ') -a.i. of P and α , the elements of $\mathcal{H}^i(A_W(C), N, W)$ are always distinct. Thus, by equidistribution of the sequence $(n\alpha)_{n \geq 1}$, the number of intersecting d -tuples equals asymptotically the product of the volumes of the sets $\gamma_w(A_W(C))$ and $\Gamma_w(A_W(C))$, i.e. we have the following lemma.

Lemma 3.3.15

$$|V^i(A_W(C), N, W)| = \begin{cases} \prod_{w \in W} N \lambda^d (\gamma_w(A_W(C))) + o(N^d) \\ = N^d \prod_{j=1}^d \lambda^{d-1} (\phi_{w_j}(\sigma)) |J_{w_j}(A_W(C))| + o(N^d) & \text{if } i = 1, \\ \prod_{w \in W} N \lambda^d (\Gamma_w(A_W(C))) + o(N^d) \\ = N^d \prod_{j=1}^d \lambda^{d-1} (\Phi_{w_j}(\sigma)) |J_{w_j}(A_W(C))| + o(N^d) & \text{if } i = 2. \end{cases}$$

We conclude this subsection with a verification of the following formula.

Lemma 3.3.16

$$\prod_{j=1}^d |J_{w_j}(A_W(C))| = \sigma^d |\text{Det}(w_1, \dots, w_d)|.$$

Proof: Let, as in Section 3.1.4, $C = C_0$ be the cube rooted at 0, i.e.,

$$C = \bigcap_{j=1}^d H_{e_j,0}^+ \cap \bigcap_{j=1}^d H_{e_j,\sigma}^-$$

where, for $1 \leq i \leq d$, $e_i \in S_{d-1}$ denotes the i -th Euclidean unit vector. The edges of C are σe_i .

Recall that, by definition, $A_W = \tau_d \circ \tau_{d-1} \circ \dots \circ \tau_1$. Moreover, all facets of $C_k = \tau_k \circ \dots \circ \tau_1(C)$ lie in the same hyperplanes as the facets of $C_{k+1} = \tau_{k+1}(C_k)$. Only the normal vectors of the facets $F_k \subseteq H_{e_k,0}$ and $F_{k+d} \subseteq H_{e_k,\sigma}$ change under τ_{k+1} . By the definition of τ_{k+1} , the new facets are subsets of $H_{w_{k+1},0}$ and $H_{w_{k+1},|e_{k+1}^k \cdot w_{k+1}|}$. Furthermore, these hyperplanes contain the facets of $A_W(C)$. Thus,

$$|J_{w_{k+1}}(A_W(C))| = |e_{k+1}^k \cdot w_{k+1}|.$$

e_{k+1}^k can be expressed as vector connecting 0 and the vertex

$$\bigcap_{i=1}^k H_{w_i,0} \cap H_{e_{k+1},\sigma} \cap \bigcap_{i=k+2}^d H_{e_i,0},$$

i.e., as the vector

$$e_{k+1}^k = (f_1(k), \dots, f_k(k), \sigma, 0, \dots, 0),$$

which is a solution of the system of linear equations

$$\begin{pmatrix} w_1 = w_1^1 \cdots \cdots w_1^d \\ \vdots \\ w_k = w_k^1 \cdots \cdots w_k^d \end{pmatrix} \begin{pmatrix} f_1(k) \\ \vdots \\ f_k(k) \\ \sigma \\ 0 \\ \vdots \\ 0 \end{pmatrix} = \begin{pmatrix} 0 \\ \vdots \\ 0 \end{pmatrix},$$

or, equivalently, of

$$\begin{pmatrix} w_1 = w_1^1 \cdots \cdots w_1^k \\ \vdots \\ w_k = w_k^1 \cdots \cdots w_k^k \end{pmatrix} \begin{pmatrix} f_1(k) \\ \vdots \\ f_k(k) \end{pmatrix} = \begin{pmatrix} -\sigma w_1^{k+1} \\ \vdots \\ -\sigma w_d^{k+1} \end{pmatrix}. \quad (3.10)$$

Applying Cramer's rule on (3.10), the $f_l(k)$, $1 \leq l \leq k$, can be expressed as

$$f_l(k) = \frac{\text{Det} \begin{pmatrix} w_1^1 \cdots w_1^{l-1} & -\sigma w_1^{l+1} & w_1^{l+1} \cdots w_1^k \\ \vdots & \vdots & \vdots \\ w_k^1 \cdots w_k^{l-1} & -\sigma w_k^{l+1} & w_k^{l+1} \cdots w_k^k \end{pmatrix}}{\text{Det} \begin{pmatrix} w_1^1 \cdots \cdots w_1^k \\ \vdots \\ w_k^1 \cdots \cdots w_k^k \end{pmatrix}} =: D_k.$$

Therefore we arrive at

$$\begin{aligned} |J_{w_{k+1}}(A_W(C))| &= |e_{k+1}^k \cdot w_{k+1}| = \left| \sum_{l=1}^j f_l(k) w_{k+1}^l + \sigma w_{k+1}^{k+1} \right| \\ &= \left| \frac{\sigma}{D_k} \left(\sum_{l=1}^j (-1)^{j-l-1} u_{j+1}^l \text{Det} \begin{pmatrix} w_1^1 \cdots w_1^{l-1} w_1^{l+1} \cdots w_1^{j+1} \\ \vdots \\ w_k^1 \cdots w_k^{l-1} w_k^{l+1} \cdots w_k^{k+1} \end{pmatrix} \right. \right. \\ &\quad \left. \left. + w_{k+1}^{k+1} D_k \right) \right| = \left| \frac{(-1)^d \sigma}{D_k} D_{k+1} \right|. \end{aligned}$$

Observe that this equation holds for any cube $C \subseteq [0, 1]^d$ and its image under the linear mapping A_W . ■

3.3.6 Finalizing the Proof

Let, according to the assumptions of Proposition 3.2.3, P be a polytope in \mathbb{T}^d with facets F_i and normal vectors u_i , $i = 1 \dots, L$. Let $\alpha \in \mathbb{T}^d$ be strongly irrational. Let P and α be σ' -a.i. Let $C = C(\sigma, x)$ be an arbitrary cube with side length $\sigma > 0$ and center x . Let σ be small enough so that $\xi(P)\sigma < \sigma'$.

Let $W = \{w_1, w_2, \dots, w_d\} \subseteq \{u_1, u_2, \dots, u_L\}$ consist of d linearly independent vectors. Combining Lemmas 3.3.15 and 3.3.16 yields for $i = 1, 2$

$$|V^i(A_W(C), N, W)| = \sigma^d N^d |\text{Det}(w_1, \dots, w_d)| \prod_{k=1}^d \begin{cases} \lambda^{d-1}(\phi_W(w_k, \sigma)) & (i = 1) \\ \lambda^{d-1}(\Phi_W(w_k, \sigma)) & (i = 2) \end{cases} + o(N^d). \quad (3.11)$$

By Section 3.3.1 and Proposition 3.3.13, for every $\varepsilon > 0$,

$$\begin{aligned} P(C, N) &\geq |\Pi^1(C, N)| \geq |V^1(C, N)| + o(N^d) \\ &\geq \sum_{\substack{W=\{w_1, \dots, w_d\} \subseteq \\ \{u_1, u_2, \dots, u_L\}}} |V^1(C, N, W)| + o(N^d) \\ &\geq \sum_{\substack{W=\{w_1, \dots, w_d\} \subseteq \\ \{u_1, u_2, \dots, u_L\}}} |V^1(A_W(C^{-\zeta}), N, W)| + o(N^d) \\ &\geq \sum_{\substack{W=\{w_1, \dots, w_d\} \subseteq \\ \{u_1, u_2, \dots, u_L\}}} (\sigma - \zeta)^d N^d |\text{Det}(w_1, \dots, w_d)| \prod_{r=1}^d \lambda^{d-1}(\phi_{w_r}(\sigma - \zeta)) \\ &\quad + o(N^d) \\ &\geq \frac{N^d (\sigma - \zeta)^d}{d!} \left(\sum_{k_1=1}^L \dots \sum_{k_d=1}^L \right. \\ &\quad \left. \left(|\text{Det}(u_{k_1}, \dots, u_{k_d})| \prod_{j=1}^d \lambda^{d-1}(\phi_{u_{k_j}}(\sigma - \zeta)) \right) \right) + o(N^d) \end{aligned}$$

and analogously (for any ζ and ε sufficiently small w.r.t. σ'),

$$\begin{aligned} P(C, N) &\leq \frac{N^d (\sigma + \varepsilon + \zeta)^d}{d!} \left(\sum_{k_1=1}^L \dots \sum_{k_d=1}^L \right. \\ &\quad \left. \left(|\text{Det}(u_{k_1}, \dots, u_{k_d})| \prod_{j=1}^d \lambda^{d-1}(\Phi_{u_{k_j}}(\sigma + \zeta + \varepsilon)) \right) \right) + o(N^d). \end{aligned}$$

Since the last two inequalities hold for any $\varepsilon, \zeta > 0$ if $N \in \mathbb{N}$ is sufficiently large we are done.

3.4 The asymptotic independence of P and α

How natural is our condition of asymptotic independence? Recall from Section 3.1.3 that σ' -a.i. states:

1. For all $s \in \{1, 2, \dots, L\}$, the number $|C_s(N)|$ of over-determined vertices on the facet $F_s^{\sigma'}$ which is induced by the N -fold translation of $\partial P^{\sigma'}$ by α , is of size $o(N^{d-1})$.
2. There are no parallel facets with nonempty intersection.

We can show the following.

Proposition 3.4.1 *Let P be a polytope in \mathbb{T}^d with facets F_r and normal vectors u_r , $r = 1, \dots, L$. Then P and α are σ' -asymptotic independent for all $\alpha \in \mathbb{T}^d \setminus M$, where M is a meager zero set.*

Proof: We first show that condition 1. holds for almost all α . For $j = 1, \dots, d$, let linearly independent normal vectors u_{r_j} , $l_j \in \{1, \dots, L\}$, positive integers $n_j \in \mathbb{N} \setminus \{0\}$ and $m_j \in (\mathbb{N} \setminus \{0\})^d$ be given. Fix the set

$$A = A_s((u_{r_i}, n_i, m_i)_{i=1}^d) := \left\{ \alpha \in [0, 1]^d : \bigcap_{j=0}^d H_{u_{r_j}, (n_j \alpha - m_j) \cdot u_{r_j}} \in H_{u_s, 0} \right\}.$$

Note that A is either empty or contained in a hyperplane in \mathbb{R}^d intersecting $[0, 1]^d$. Hence it is a set of measure 0 (w.r.t. λ^d) that does not have inner points. By the same arguments also the sets

$$A(s) := \bigcup_{\substack{u_{r_1}, \dots, u_{r_d} \\ \text{linearly independent}}} \bigcup_{n_1, \dots, n_d \in \mathbb{N}} \bigcup_{m_1, \dots, m_d \in \mathbb{N}^d} A_s((u_{r_i}, n_i, m_i)_{i=1}^d)$$

are meager zero sets in $[0, 1]^d$ for all $s \in \{1, \dots, L\}$. Let

$$A'(s) = \bigcup_{\substack{u_{r_1}, \dots, u_{r_d} \\ \text{linearly independent}}} \bigcup_{n_1, \dots, n_d \in \mathbb{N}} \left\{ \alpha \in \mathbb{T}^d : \bigcap_{j=0}^d H_{u_{r_j}, \{n_j \alpha\} \cdot u_{r_j}} \in H_{u_s, 0} \right\}.$$

Observe that $A(s) \supseteq A'(s)$.

If α in $[0, 1)^d \setminus A(s)$, then, for all $s \in \{1, \dots, L\}$, and for facets F_{r_1}, \dots, F_{r_d} , $r_j \in \{1, \dots, L\} \setminus \{s\}$, with linearly independent u_{r_j} , there exists at most one d tuple $(n_1, \dots, n_d) \in \mathbb{N}^d$ such that

$$\left(\bigcap_{j=1}^d (F_{r_j}^{\sigma'} - n_j \alpha) \right) \in F_s^{\sigma'}.$$

Hence, for every $s \in \{1, \dots, L\}$, the set $F_s^{\sigma'}$ contains at most one intersection point $\bigcap_{j=1}^d F_{r_j} - n_j \alpha$, for every choice of facets F_{r_j} with linearly independent u_{r_j} , $j = 1, \dots, d$.

Therefore, for almost all α , there are altogether at most $\binom{L-1}{d}$ intersection points in F_s proving condition 1.

In a similar way we show that the set of those α , for which condition 2 fails, is small:

The set $(\partial(P + (\sigma')) - n\alpha) \cap (\partial P + \sigma')$ contains a $(d-1)$ -dimensional set only if there are two facets F_r and F_s of P , $1 \leq r, s \leq L$, such that $(F_r^{\sigma'} - n\alpha) \cap F_s^{\sigma'}$ contains a $(d-1)$ -dimensional set. If $F_r \subseteq H_{u_r, \lambda_r}$ and $F_s \subseteq H_{u_s, \lambda_s}$, this is only possible if $u_r = \pm u_s$ and if for the normal distance δ between these hyperplanes holds

$$|(n\alpha - k) \cdot u_r| = \delta$$

for a suitable vector $k = (k_1, \dots, k_d) \in \mathbb{Z}^d$. Let $k \in \mathbb{Z}^d$, $n \in \mathbb{N}$, $\delta \geq 0$ and $u \in S_{d-1}$. Then

$$B(u, \delta, k, n) = \{\alpha \in \mathbb{R}^d : (n\alpha - k) \cdot u = \delta\}$$

defines a hyperplane. Thus

$$B(u, \delta) = \bigcup_{n \in \mathbb{N}} \bigcup_{k \in \mathbb{Z}^d} B(u, \delta, k, n)$$

is a meager zero set. Since P is a polytope, only finitely many choices for $u \in S_{d-1}$ and $\delta \geq 0$ are possible (for every u_i , $i \in \{1, \dots, L\}$, $\delta = 0$ is possible). ■

3.5 Further remarks

The following natural question arises: Does a similar relation hold for more general convex bodies and their coding sequences? It is known that the volume of the projection body is continuous w.r.t. the Hausdorff metric. It seems that our approach allows to verify a similar continuity-type result in dimension $d = 2$. A detailed investigation of this special case and the general d -dimensional case would be interesting for future research.

Let us remark that one cannot hope for continuity of the asymptotic complexity w.r.t. the Hausdorff metric. One always has to respect dependencies of the coded set and the generating element. In the present chapter these dependencies were controlled via the σ' -asymptotic independence. If P and α are not σ' -a.i. the value of the asymptotic complexity changes. An example for this situation has been discussed in Remark 2.1.2,2.

Bibliography

- [1] P. Alessandri: Codages de rotations et basses complexités. Université Aix Marseille II. PhD thesis, 1996.
- [2] P. Alessandri, V. Berthé: Three distance theorems and combinatorics on words. *Enseig. Math.*, 44, 103–132, 1998.
- [3] P. Arnoux, V. Berthé, S. Ferenczi, S. Ito, C. Mauduit, M. Mori, J. Peyrière, A. Siegel, J.– I. Tamura, Z.– Y. Wen: Substitutions in Dynamics, Arithmetics and Combinatorics. *Lecture Notes in Mathematics 1794*. Springer Verlag, Berlin – Heidelberg – New York, 2002.
- [4] G. Barbieri, D. Dikranjan, C. Milan, H. Weber: t -dense subgroups of topological Abelian groups. Preprint, 2004.
- [5] G. Barbieri, D. Dikranjan, C. Milan, H. Weber: Answer to Raczkowski's question on convergent sequences of integers. *Top. Appl.*, 132, 1 (2003), 89–101.
- [6] M. Beiglböck: Strong characterizing sequences of countable groups. Preprint, 2003.
- [7] M. Beiglböck, C. Steineder: Quasi convex sets. Manuscript.
- [8] M. Beiglböck, C. Steineder, R. Winkler: Sequences and filters of characters characterizing subgroups of compact abelian groups. to appear in *Top. Appl.*
- [9] V. Berthé: Sequences of low complexity: Automatic and Sturmian sequences. *Topics in Symbolic Dynamics and Applications*. Lond. Math. Soc, Lecture Notes 279, 1–28, Cambridge University Press, 2000.

- [10] A. Biró: Characterizing sets for subgroups of compact groups I.: a special case. Preprint, 2004.
- [11] A. Biró: Characterizing sets for subgroups of compact groups II.: general case. Preprint, 2004.
- [12] A. Biró, J–M. Deshouillers, V. T. Sós: Good approximation and characterization of subgroups in \mathbb{R}/\mathbb{Z} . *Studia Sci. Math. Hung.*, 38 (2001), 97–113.
- [13] A. Biró, V. T. Sós: Strong characterizing sequences in simultaneous diophantine approximation. *J. of Number Theory*, 99 (2003), 405–414.
- [14] M. Denker, Ch. Grillenberger, K. Sigmund: *Ergodic Theory on Compact Spaces*. Lecture Notes in Mathematics 527. Springer, Heidelberg, 1976.
- [15] D. Dikranjan: Topologically torsion elements of topological groups. *Topology Proc.*, 26 (2001–2002), 505–532.
- [16] D. Dikranjan, K. Kunen: Characterizing subgroups of compact abelian Groups. Preprint, 2004.
- [17] D. Dikranjan, C. Milan, A. Tonolo: A characterization of the maximally almost periodic Abelian groups. *J. Pure Appl. Algebra*, to appear.
- [18] D. Dikranjan, I. R. Prodanov, L. N. Stoyanov: *Topological Groups. Characters, Dualities and Minimal Group Topologies*. Marcel Dekker, Inc. New York and Basel (1990).
- [19] P. Eliaš: Covering for category and trigonometric thin sets. *Proc. Am. Math. Soc.*, 131, No.10 (2003), 3241–3249.
- [20] H. G. Eggelston: Sets of fractional dimension which occur in some problems of number theory. *Proc. Lond. Math. Soc.* 54 (1952), 42–93.
- [21] P. Erdős, S. J. Taylor: On the set of points of a lacunary trigonometric series and the equidistribution properties of related sequences. *Proc. London Math. Soc.*, 3 (1957), 598–615.
- [22] S. Frisch, M. Pašteka, R. F. Tichy, R. Winkler: Finitely additive measures on groups and rings. *Rend. Circolo Mat. di Palermo*, 48 Series II, 323–340, 1999.

- [23] G. A. Hedlund, M. Morse: Symbolic dynamics I. Amer. J. Math. 60, 815–866, 1938.
- [24] G. A. Hedlund, M. Morse: Symbolic dynamics II. Amer. J. Math. 62, 1–42, 1940.
- [25] A. Heinis: Arithmetics and combinatorics of words of low complexity. PhD thesis, 2001.
- [26] A. Heinis, R. Tijdeman: Characterisation of asymptotically sturmian sequences. Publ. Math. Debrecen 56 (2000), 223–234.
- [27] E. Hewitt, K. Ross: Abstract Harmonic Analysis. Vol. 1, Springer Verlag, Berlin – Heidelberg – New York, 1963.
- [28] J. Justin, L. Vuillon: Return words in Sturmian and episturmian words. Theor. Inform. Appl., 34 (2000), 343–356.
- [29] L. Kuipers, H. Niederreiter: Uniform Distribution of Sequences. A. Wiley – Interscience Publ., New York, 1974.
- [30] G. Larcher: A convergence problem connected with continued fractions. Proc. Am. Math. Soc. 103, No.3 (1988), 718–722.
- [31] M. Ludwig, M. Reitzner, F. Schuster: Convex geometry. Oral communication, 2004.
- [32] G. Maresch: Filters and subgroups associated with Hartman measurable functions. Preprint, 2005.
- [33] G. Maresch, R. Winkler: Hartman measurable functions and related function spaces. Preprint, 2005.
- [34] G. Rote: Sequences with subword complexity $2n$. J. Number Theory, 46 (1994), 196–213.
- [35] J. Schmeling, E. Szabó, R. Winkler: Hartman and Beatty bisequences. Algebraic Number Theory and Diophantine Analysis, 405–421, Walter de Gruyter, Berlin, 2000.
- [36] R. Schneider: Convex Bodies: the Brunn–Minkovski theory. Cambridge Univ. Press, 1993.

- [37] R. Schneider: Random hyperplanes meeting a convex body. *Z. Wahrscheinlichkeitsth. verw. Geb.* 61 (1981), 379–387.
- [38] C. Steineder: Complexity of Hartman sequences and a connection to convex geometry. Manuscript.
- [39] C. Steineder: $n\alpha$ Folgen seit Hermann Weyl. Master theses, Vienna, 2002.
- [40] C. Steineder, R. Winkler: Complexity of Hartman sequences. to appear in *Jour. Th. N. Bord.*
- [41] L. Vuillon: A characterization of Sturmian words by return words. *European J. Combin.*, 22 (2001), 263–275.
- [42] P. Walters: *An Introduction to Ergodic Theory*. Grad. Texts in Math. Springer Verlag New York, 2000.
- [43] H. Weyl: Über die Gleichverteilung von Zahlen mod. Eins. *Math. Ann.*, 77 (1916), 313–352.
- [44] R. Winkler: Ergodic group rotations, Hartman sets and Kronecker sequences. *Monatsh. Math.*, 135 (2002), 333–343.

Curriculum Vitae

Personal Information

Name: Christian Steineder
Date/ place of birth: 09.03.1975/ Vienna, Austria
Marital status: unmarried
Citizenship: Austria
Address: Josef Bühl Gasse 29,
1230 Vienna, Austria
Telephone (home): +43 699 110 38483
Telephone (office): +43 1 58801 10463
E-mail: christian.steineder@tuwien.ac.at

Education / Career

June 1993 Graduation from high school
Kalksburg
1993–1995 Studies of biotechnology at the
University of Natural Resources and
Applied Life Sciences of Vienna
1995 – 2000 Studies of mathematics at the
Vienna University of Technology
2000–2001 Civil service
2001– June 2002 Master thesis
*Uniform distribution of sequences
since Hermann Weyl*
2002–2003 Research position at the
Austrian Academy of Sciences
2003 –2004 Research position within the
FWF project S8302 at the
Vienna University of Technology
Since 2003 Research position within the
FWF project S8312 at the
Vienna University of Technology
Since 2003 Teaching assistant at the
Vienna University of Technology