



TECHNISCHE
UNIVERSITÄT
WIEN

Dissertation

THE HIGHER CICHÓN DIAGRAM

ausgeführt zum Zwecke der Erlangung des akademischen Grades eines
Doktors der technischen Wissenschaften
unter Anleitung von

Ao.Univ.Prof. Dipl.–Ing. Dr.techn. Martin Goldstern

Institut für Diskrete Mathematik und Geometrie
Wiedner Hauptstraße 8–10, 1040 Wien
martin.goldstern@tuwien.ac.at

eingereicht an der Fakultät für Mathematik und Geoinformation der
Technischen Universität Wien von

Dipl.–Ing. Thomas Baumhauer, BSc

thomas.baumhauer@gmail.com

Dezember 2018

Abstract

For a strongly inaccessible cardinal κ , Saharon Shelah generalized the notion of Lebesgue null sets on the Cantor space 2^ω to the “Higher Cantor space” 2^κ (Archive for Mathematical Logic, 2017). In this thesis we investigate, for such κ , the relationships between the following ideals:

1. the ideal of meager sets in the $<\kappa$ -box product topology.
2. the ideal of null sets in the sense of Shelah.
3. the ideal of nowhere stationary subsets of a (naturally defined) stationary set $S_{\text{pr}}^\kappa \subseteq \kappa$.

In particular, we analyse the provable inequalities between the cardinal characteristics for these ideals, and we give consistency results showing that certain inequalities are unprovable.

While some results from the classical case ($\kappa = \omega$) can be easily generalized to our setting, some key results (such as a Fubini property for the ideal of null sets) do not hold; this leads to the surprising inequality $\text{cov}(\text{null}) \leq \text{non}(\text{null})$. Also, concepts that did not exist in the classical case (in particular, the notion of stationary sets) will turn out to be relevant.

We construct several models to distinguish the various cardinal characteristics; the main tools are iterations with $<\kappa$ -support (and a strong “Knaster” version of κ^+ -c.c.) and one iteration with $\leq\kappa$ -support (and a version of κ -properness).

Kurzfassung

Für eine stark unerreichbare Kardinalzahl κ hat Saharon Shelah den Begriff der Lebesgue-Nullmengen auf dem Cantor-Raum 2^ω auf den “höheren Cantor-Raum” 2^κ verallgemeinert (Archive for Mathematical Logic, 2017). In dieser Arbeit untersuchen wir für solches κ die Beziehungen zwischen folgenden Idealen:

1. dem Ideal der mageren Mengen in der $<\kappa$ -box-Produkttopologie.
2. dem Ideal der Nullmengen im Sinne Shelahs.
3. dem Ideal der nirgends stationären Teilmengen einer (natürlich definierten) stationären Menge $S_{\text{pr}}^\kappa \subseteq \kappa$.

Im Besonderen analysieren wir die beweisbaren Ungleichungen zwischen den Kardinalzahlcharakteristiken dieser Ideale und beweisen Konsistenzresultate, die zeigen, dass bestimmte Ungleichungen unbeweisbar sind.

Während manche Ergebnisse aus dem klassischen Fall ($\kappa = \omega$) leicht verallgemeinert werden können, gelten andere Eigenschaften nicht mehr (wie zum Beispiel die Fubini-Eigenschaft des Ideals der Nullmengen). Dies führt zu der überraschenden Ungleichung $\text{cov}(\text{null}) \leq \text{non}(\text{null})$. Weiters beginnen andere Konzepte, die im klassischen Fall nicht existieren (im Besonderen stationäre Mengen), eine Rolle zu spielen.

Wir konstruieren mehrere Modelle, um verschiedene Kardinalzahlcharakteristiken zu trennen; Die Werkzeuge hierzu sind Forcing-Iterationen mit $<\kappa$ -Träger, (und eine starke “Knaster”-Variante der κ^+ -c.c.), sowie eine Iteration mit $\leq\kappa$ -Träger (und eine Variante von κ -properness).

Contents

Abstract	iii
Kurzfassung	v
Acknowledgements	ix
Introduction	xi
1 Preliminaries	1
1.1 The Generalized Random Forcing \mathbb{Q}_κ	1
1.2 The Generalized Null Ideal	7
1.3 Quantifiers and Rational Translates	11
1.4 The Property $\text{Pr}(\cdot)$ and the Nowhere Stationary Ideal	12
1.5 Ideals and Strengthened Galois-Tukey Connections	16
1.6 Miscellaneous	18
2 Tools	19
2.1 Closure	19
2.2 Stationary Knaster, preservation in $<\kappa$ -support iterations	21
2.3 κ -centered $_{<\kappa}$, preservation in $<\kappa$ -support iterations	24
2.4 The Fusion Game, preservation in κ -support iterations	30
2.5 Fusion and Properness	37

3	Smaller Ideals	41
3.1	The ideal $\text{id}(\mathbb{Q}_\kappa)$	41
3.2	The ideal $\text{id}^-(\mathbb{Q}_\kappa)$	42
3.3	Characterizing Additivity and Cofinality	46
3.4	Strong measure zero sets	60
4	$\text{id}(\mathbb{Q}_\kappa)$ in the \mathbb{Q}_κ-Extension	63
4.1	Asymmetry	63
4.2	Upwards absoluteness of $\text{id}(\mathbb{Q}_\kappa)$	67
4.3	Miscellaneous	68
5	ZFC-Results	71
5.1	Cichoń's Diagram	71
5.2	On $\text{add}(\mathbb{Q}_\kappa) \leq \text{add}(\text{Cohen}_\kappa)$	81
6	Models	87
6.1	The Cohen Model	87
6.2	The Hechler Model	89
6.3	The Short Hechler Model	92
6.4	Amoeba forcing, part 1	93
6.5	Amoeba forcing, part 2	97
6.6	Iterated Amoeba Forcing	100
6.7	The Short Amoeba Model	102
6.8	Cohen-Amoeba Forcing	103
6.9	Bounded Perfect Tree Forcing	106
7	Slaloms	111
7.1	Recapitulation	111
7.2	Separating Partial Slaloms from $\text{id}(\mathbb{Q}_\kappa)$	114
7.3	On Total Slaloms and $\text{id}(\mathbb{Q}_\kappa)$	116
	List of Figures	119
	Bibliography	121

Acknowledgements

I am thankful to my advisor Martin Goldstern for his patient supervision during the creation of this thesis. I am thankful to Saharon Shelah for being generous with his ideas.

I gratefully acknowledge the following (partial) support: by the Austrian Science Fund through grant FWF P29575; by the European Research Council under grant ERC-2013-ADG-338821; by the National Science Foundation NSF grant no: 136974;

Introduction

Set theory of the reals deals with topological, measure-theoretic and combinatorial properties of the real line, which set theorists often do not interpret as the linear continuum \mathbb{R} , but (often for technical or notational convenience) as the Cantor space 2^ω or the Baire space ω^ω .

In this thesis we will be interested in a natural generalization of such properties to the spaces 2^κ and κ^κ for uncountable (and in our setup: always inaccessible) cardinals κ . This area of research has progressed quickly in recent years; (Khomskii, Laguzzi, Löwe, and Sharankou 2016) collected many questions inspired by workshops on generalized reals, and several recent results can be found in (Brendle, Brooke-Taylor, Friedman, and Montoya 2018), (Friedman and Laguzzi 2017), (Shelah 2017), (Cohen and Shelah 201x).

We will occasionally refer to results or definitions involving 2^ω or ω^ω ; to emphasize the distinction between this framework and our setup, we will use the adjective “classical” to refer to these concepts: the classical Cichoń diagram, classical random reals, etc.

Concerning terminology, we suggested to use the adjective “higher” instead of the less specific “generalized” or “generalised”. In analogy to *higher Souslin trees* (Souslin trees on cardinals larger than ω_1), *higher recursion theory* (recursion theory on ordinals greater than ω), *higher descriptive set theory* we will speak of higher reals, the higher Cantor space, higher random reals, the higher Cichoń diagram, etc.

Higher random reals

There exists a straightforward generalization the meager ideal on 2^ω (or ω^ω) to an ideal on 2^κ for (regular) $\kappa > \omega$, using the $<\kappa$ -box product topology and defining a set as meager if it can be covered by $\leq\kappa$ -many (closed) nowhere dense sets.

In (Shelah 2017) Saharon Shelah introduced a generalization \mathbb{Q}_κ of the random forcing to 2^κ for inaccessible κ . The forcing \mathbb{Q}_κ is strategically κ -closed, satisfies the κ^+ -chain condition and for weakly compact κ is κ^κ -bounding. These are of course three properties that are satisfied by classical random forcing (i.e., on $\kappa = \omega$). The ideal $\text{id}(\mathbb{Q}_\kappa)$ generated by all κ -Borel which are forced not to contain the \mathbb{Q}_κ -generic κ -real turns out to be orthogonal to the ideal Cohen_κ of all κ -meager sets.

In (Cohen and Shelah 201x) it is shown how to replace the requirement of κ being weakly compact by assuming the existence of a stationary set that reflects only in inaccessibles and has a diamond sequence. A construction of a κ^+ -c.c. κ^κ -bounding forcing notion using a different diamond is given in (Friedman and Laguzzi 2017) but it implies $2^\kappa = \kappa^+$, so that setup does not allow us to investigate cardinal characteristics.

A different approach can be found in (Brendle, Brooke-Taylor, Friedman, and Montoya 2018) where the authors use the well known characterization of the additivity and cofinality of the null ideal by slaloms (in the classical case ($\kappa = \omega$), see for example (Bartoszyński and Judah 1995)) to define their versions of $\text{add}(\text{null})$ and $\text{cof}(\text{null})$ on 2^κ for inaccessible κ .

We continue the work of (Shelah 2017), and we also compare our cardinal characteristics to those derived from slaloms.

Overview of the thesis

The research I did on the higher Cichoń diagram is collected in (Baumhauer, Goldstern, and Shelah 2018) which can be considered a sequel of (Shelah 2017). This thesis is essentially a self-contained version of (Baumhauer, Goldstern, and Shelah 2018), including all necessary definitions and results (and in particular proofs) from its predecessor.

- In section 1 we repeat some key definitions and results from (Shelah 2017), introduce some notations and finally define the notion of a strengthened Galois-Tukey connection.
- In section 2 we prove preservation theorems for iterations of $<\kappa$ and κ -support.
- In section 3 we introduce an ideal $\text{id}^-(\mathbb{Q}_\kappa) \subseteq \text{id}(\mathbb{Q}_\kappa)$ whose definition is slightly simpler than the definition of $\text{id}(\mathbb{Q}_\kappa)$; however, for weakly compact κ the ideals id and id^- coincide. We improve the characterizations of the additivity and cofinality of $\text{id}(\mathbb{Q}_\kappa)$ given in (Shelah 2017) and also give a new characterization of additivity and cofinality, using the additivity of the ideal of nowhere stationary sets on κ .
- In section 4 we generalize a theorem from (Shelah 2017) by introducing the notion of an anti-Fubini set and showing the existence of such set implies the result for arbitrary ideals.
- In section 5 we repeat and elaborate results from (Shelah 2017) and discuss the Bartoszyński-Raisonnier-Stern theorem for $\text{id}(\mathbb{Q}_\kappa)$. We can show it for inaccessible κ only under additional assumptions, and we conjecture that it does not hold in general.
- In section 6 we provide six models separating characteristics of the generalized Cichoń diagram using the tools developed in section 2. Curiously we do exactly all possible vertical separations.
- In section 7 we repeat some definitions and results from (Brendle, Brooke-Taylor, Friedman, and Montoya 2018) and use a model from that paper to show that one of the generalized slalom characterizations of the additivity of null is not provably equal to the additivity of $\text{id}(\mathbb{Q}_\kappa)$.

CHAPTER 1

Preliminaries

In this section we establish some key definitions and results from (Shelah 2017).

1.1 The Generalized Random Forcing \mathbb{Q}_κ

To motivate the main definition of this section, we first give a characterisation of random forcing; the definition of \mathbb{Q}_κ can then be seen as a generalization.

Definition 1.1.1. A “positive tree on ω ” is a set $T \subseteq 2^{<\omega}$ with the following properties:

- T is a tree, i.e.: T is nonempty, and for all $t \in T$ and all initial segments $s \trianglelefteq t$ we also have $s \in T$.
- There is a family $(N_k : k \in \omega)$, with $N_k \subseteq 2^k$ such that:
 - The sets N_k are small, more precisely: $\sum_k \frac{|N_k|}{2^k} < 1$.
 - For all k , all $s \in 2^k$: $s \in T \iff ((\forall n < k) s \upharpoonright n \in T \text{ and } s \notin N_k)$.

It is easy to see that a tree T is positive in this sense if and only if the set $[T]$ of branches of T has positive Lebesgue measure in 2^ω . Thus, the set of positive trees is isomorphic to (a dense subset of) random forcing.

It is well-known and easy to see that the ideal of null sets can be defined from the random forcing in several ways:

Fact 1.1.2. Let $A \subseteq 2^\omega$. Then each of the following properties is equivalent to the statement “ A is Lebesgue measurable with measure 0”:

- For all positive trees p there is a positive tree $q \subseteq p$ such that $[q] \cap A = \emptyset$.
- There is a predense set \mathcal{C} of positive trees such that $A \cap \bigcup_{p \in \mathcal{C}} [p] = \emptyset$.
- There is a single positive tree p such that not only $[p] \cap A = \emptyset$, but for every $s \in 2^{<\omega}$ we also have $(s + [p]) \cap A = \emptyset$.

Here, we write $s + X$ for the set $\{s + x : x \in X\}$, where $s + x \in 2^\omega$ is defined by $(s + x)(i) = s(i) + x(i)$ for $i \in \text{dom}(s)$, and $(s + x)(i) = s(i)$ otherwise. ($s + X$ is also called a “rational translate” of X .)

Definition 1.1.3. Unless stated otherwise, κ denotes an strongly inaccessible cardinal throughout this paper. When we write “inaccessible” we will always mean “strongly inaccessible” and for the set of all inaccessible cardinals below κ we write

$$S_{\text{inc}}^\kappa = \{\lambda < \kappa : \lambda \text{ is inaccessible}\}.$$

Definition 1.1.4. Let $S \subseteq \kappa$. We say that S is *nowhere stationary* if for every $\delta \leq \kappa$ of uncountable cofinality the set $S \cap \delta$ is a nonstationary subset of δ . Typically we will only care about being nonstationary in $\delta \in S_{\text{inc}}^\kappa \cup \{\kappa\}$.

We will now inductively define, for every inaccessible cardinal κ ,

- a forcing notion \mathbb{Q}_κ (this definition uses the ideals $\text{id}(\mathbb{Q}_\delta)$ for $\delta < \kappa$)
- two ideals $\text{wid}(\mathbb{Q}_\kappa) \subseteq \text{id}(\mathbb{Q}_\kappa)$ on 2^κ .

(The ideals coincide for weakly compact κ , see 3.2.3.)

Definition 1.1.5. We recall the inductively defined forcing \mathbb{Q}_κ from (Shelah 2017, 1.3). We have $p \in \mathbb{Q}_\kappa$ if there exists $(\tau, S, \vec{\Lambda}_\delta : \delta \in S)$ (this tuple is called the *witness* for $p \in \mathbb{Q}_\kappa$) where:

1. $p \subseteq 2^{<\kappa}$ is a tree, i.e. closed under initial segments.
2. $\tau \in 2^{<\kappa}$ is the trunk of p , i.e., the least node which has two successors.
3. Above τ the tree p is fully branching, i.e. $\tau \trianglelefteq \eta \in p \Rightarrow \eta \frown 0, \eta \frown 1 \in p$.
4. $S \subseteq S_{\text{inc}}^\kappa$ is nowhere stationary.

5. For $\delta \in S$ the set Λ_δ satisfies:

- (a) $\mathcal{I} \in \Lambda_\delta \Rightarrow \mathcal{I}$ is a predense subset of \mathbb{Q}_δ .
- (b) $|\Lambda_\delta| \leq \delta$.

6. If $\delta \notin S$ is a limit ordinal and $\eta \in 2^\delta$, then: $\eta \in p$ iff $(\forall \sigma < \delta) \eta \upharpoonright \sigma \in p$.

7. If $\delta \in S$ is a limit ordinal and $\eta \in 2^\delta$, then: $\eta \in p$ iff

- (a) $(\forall \sigma < \delta) \eta \upharpoonright \sigma \in p$ and
- (b) $(\forall \mathcal{I} \in \Lambda_\delta)(\exists q \in \mathcal{I}) \eta \in [q]$.

For $p, q \in \mathbb{Q}_\kappa$ we define q stronger than p if $q \subseteq p$. We write $q \leq p$ for “ q stronger than p ” throughout this paper (and we use this convention for any forcing, not just \mathbb{Q}_κ).

If G is a \mathbb{Q}_κ -generic filter then we call $\eta = \bigcup_{p \in G} \text{tr}(p) \in 2^\kappa$ a \mathbb{Q}_κ -generic real or a “random real”, where $\text{tr}(p)$ is the trunk of p . Alternatively, η is the unique element of $\bigcap_{p \in G} [p]$, where $[p]$ is the set of cofinal branches of p .

Remark 1.1.6. Note that the set $S \cap \text{lg}(\tau)$ (where $\text{lg}(\tau)$ is the order type of the predecessors of τ) is really irrelevant; if we require $\min(S) > \text{lg}(\tau)$, then p is uniquely defined by its witness and vice versa.

So given $p \in \mathbb{Q}_\kappa$ we may write $\text{tr}(p)$, S_p and $\vec{\Lambda}_p$ for the unique elements such that $(\text{tr}(p), S_p, \vec{\Lambda}_p)$ is a witness for $p \in \mathbb{Q}_\kappa$.

Fact 1.1.7.

1. Let $\eta \in 2^{<\kappa}$. Then $(2^{<\kappa})^{[\eta]} \in \mathbb{Q}_\kappa$.
2. $2^{<\kappa}$ is the maximal element of \mathbb{Q}_κ .
3. Let $p \in \mathbb{Q}_\kappa$ with witness $(\tau, S, \vec{\Lambda})$ and let $\lambda < \kappa$ be inaccessible with $|\tau| < \lambda$. Then $p \cap 2^{<\lambda} \in \mathbb{Q}_\lambda$.
4. Let $p \in \mathbb{Q}_\kappa$ and let $\eta \in p$ with witness $(\tau, S, \vec{\Lambda})$. Then $p^{[\eta]} \in \mathbb{Q}_\kappa$ and $p \geq p^{[\eta]}$.

Proof.

1. $(\eta, \emptyset, \langle \rangle)$ is a witness.

2. By (1) we have $2^{<\kappa} = (2^{<\kappa})^{[\emptyset]} \in \mathbb{Q}_\kappa$. Maximality is obvious.

3. $(\tau, S \cap \lambda, \vec{\Lambda} \upharpoonright \lambda)$ is a witness.

4. $(\tau \cup \eta, S, \vec{\Lambda})$ is a witness. □

Remark 1.1.8. Let $p, q \in \mathbb{Q}_\kappa$. Then p and q are compatible in \mathbb{Q}_κ iff at least one of the following holds:

1. $\text{tr}(p) \trianglelefteq \text{tr}(q) \in p$

2. $\text{tr}(q) \trianglelefteq \text{tr}(p) \in q$

In particular, two conditions with the same stem are always compatible.

Moreover, if p and q are compatible, then $p \cap q$ is the weakest condition in \mathbb{Q}_κ which is stronger than both.

As a consequence, any set $\mathcal{C} \subseteq \mathbb{Q}_\kappa$ with the property

$$(\forall \eta \in 2^{<\kappa})(\exists p \in \mathcal{C}) \text{tr}(p) = \eta$$

is predense in \mathbb{Q}_κ .

Lemma 1.1.9 ((Shelah 2017, 1.5)). *Let $\vec{p} = \langle p_i : i < \delta < \kappa \rangle$ be a decreasing sequence in \mathbb{Q}_κ such that*

$$\delta \leq \theta = \sup_{i < \delta} \text{lg}(\text{tr}(p_i)) \notin S(p_\alpha)$$

for all $\alpha < \delta$. Then $p_\delta = \bigcap \{p_i : i < \delta\}$ is a lower bound for \vec{p} .

Proof. For $i < \delta$ let $(\tau_i, S_i, \vec{\Lambda}_i)$ be a witness for p_i .

Clearly $\langle \tau_i : i < \delta \rangle$ is a \trianglelefteq -increasing sequence. Let $\tau_\delta = \bigcup_{i < \delta} \tau_i$ and of course $\text{lg}(\tau_\delta) = \theta$. By our assumption $\theta \notin S(p_i)$ we have $\tau_\delta \in p_i$ for $i < \delta$.

Let $S = \bigcup_{i < \delta} S_i \setminus (\theta + 1)$. Let $\vec{\Lambda}_i = \langle \Lambda_{i,\lambda} : \lambda \in S_i \rangle$ and let $\Lambda_\lambda = \{\Lambda_{i,\lambda} : i < \delta, \lambda \in S_i\}$ for $\lambda \in S$. Clearly $|\Lambda_\lambda| \leq \delta \cdot \lambda = \lambda$.

This shows that $(\tau_\delta, S, \langle \Lambda_\lambda : \lambda \in S \rangle)$ is a witness for $p_\delta \in \mathbb{Q}_\delta$. □

Lemma 1.1.10 ((Shelah 2017, 1.5)). *Let $p \in \mathbb{Q}_\kappa$, let $\rho \in p$ and let $\vec{\mathcal{J}} = \langle \mathcal{J}_i : i < \delta \leq \kappa \rangle$ be a sequence of dense subsets for \mathbb{Q}_κ . Then there exists $\eta \in 2^\kappa$ such that $\rho \trianglelefteq \eta \in [p]$ and $(\forall i < \delta)(\exists q \in \mathcal{J}_i) \eta \in [q]$, i.e. $\eta \in \text{set}_1(\vec{\mathcal{J}})$.*

Note that for $\delta = 0$ the Lemma simply states that every $\rho \in p$ is contained in a branch of p of height κ .

Proof. We prove the Lemma by induction on inaccessible κ .

Let $(\tau, S, \vec{\Lambda})$ be a witness for p .

Case 1: $\sup(S_{\text{inc}}^\kappa) = \chi < \kappa$.

- Case 1a: $\chi \in S$. In this case χ is inaccessible. Use the induction hypothesis for $p \cap 2^{<\chi}$ and Λ_χ to find $\nu \in p \cap 2^\chi$.
- Case 1b: $\chi \notin S$. Remember S is not stationary in χ and work similarly to case 2 to find $\nu \in p \cap 2^\chi$.

Now for in both case 1a and 1b find $\eta \in [p] \cap \text{set}_1(\vec{\mathcal{J}})$ such that $\nu \leq \eta$ using the Baire category theorem for 2^κ .

Case 2: $\sup(S_{\text{inc}}^\kappa) = \kappa$. We construct $\langle p_i, \alpha_i, q_i : i < \kappa \rangle$ such that:

1. $\alpha_i < \kappa$, increasing continuous with i .
2. $p_i \in \mathbb{Q}_\kappa$, decreasing with i .
3. $\text{tr}(p_i) \in 2^{\alpha_i}$.
4. $q_i \in \mathcal{J}_i$
5. $i = j + 1 \Rightarrow p_i \leq q_j$.

How can we carry out this construction? For $i = j + 1$ find $q_j \in \mathcal{J}_j$ such that $q_j \not\leq p_j$ so let $r_i \leq q_j, p_j$. Let E be a club disjoint from S and for $k \leq j$ let E_k be a club disjoint from $S(q_k)$. Choose α_i such that $(\alpha_j, \alpha_i) \cap E \cap \bigcap_{k < j} E_k \neq \emptyset$ and use the induction hypothesis to find $\nu_i \in 2^{\alpha_i} \cap r_i$. Let $p_i = r_i^{[\nu_i]}$.

For i limit use 1.1.9.

Now check that $\eta = \bigcup_{i < \kappa} \text{tr}(p_i)$ is as required. □

Corollary 1.1.11. \mathbb{Q}_κ is κ -strategically closed.

Proof. By 1.1.9. □

Corollary 1.1.12. Let $p, q \in \mathbb{Q}_\kappa$. Then p, q are compatible iff

$$[p] \cap [q] \neq \emptyset$$

Proof. By 1.1.10. □

Theorem 1.1.13. \mathbb{Q}_κ is κ -linked. In particular \mathbb{Q}_κ satisfies the κ^+ -chain condition.

Proof. If $p, q \in \mathbb{Q}_\kappa$ have the same trunk they are compatible (see 1.1.8). Because κ is inaccessible we have $|2^{<\kappa}| = \kappa$ and hence

$$\mathbb{Q}_\kappa = \bigcup_{\rho \in 2^{<\kappa}} \{p \in \mathbb{Q}_\kappa : \text{tr}(p) = \rho\}$$

shows that \mathbb{Q}_κ is κ -linked. □

Theorem 1.1.14 (κ^κ -bounding, (Shelah 2017, 1.9)). *Let κ be weakly compact. Then \mathbb{Q}_κ is κ -bounding, i.e. for every $f \in \kappa^\kappa \cap \mathbf{V}^{\mathbb{Q}_\kappa}$ there exists $g \in \kappa^\kappa \cap \mathbf{V}$ such that $f \leq g$, i.e. $(\forall i < \kappa) f(i) \leq g(i)$.*

Proof. Let $p \in \mathbb{Q}_\kappa$ and \dot{f} be a \mathbb{Q}_κ -name such that $p \Vdash \dot{f} \in \kappa^\kappa$. For $i < \kappa$ we construct $p_i, \beta_i, S_i, \vec{\Lambda}_i, E_i$ such that for all $i \leq \kappa$ we have:

- (1) $p_i \in \mathbb{Q}_\kappa$ witnessed by $(\text{tr}(p), S_i, \vec{\Lambda}_i)$, $p_0 = p$, p_i decreasing with i .
- (2) $E_i \subseteq \kappa$ is a club disjoint from S_i , \subseteq -decreasing with i .
- (3) $\beta_i \in E_i$, increasing continuous with i , $\beta_0 = \text{lg}(\text{tr}(p))$.
- (4) For $j < i$ we have $p_j \cap 2^{<\beta_j} = p_i \cap 2^{<\beta_j}$.
- (5) If $i = j + 1$ and $\nu \in p_i \cap 2^{\beta_i}$ then $p_i^{[\nu]}$ forces a value $\dot{f}(j)$.

For $i = j + 1$ let $\{q_{j,\alpha} : \alpha < \kappa\}$ be a maximal antichain of \mathbb{Q}_κ such that for every $\alpha < \kappa$ we have:

1. $q_{j,\alpha}$ forces a value $\gamma(j, \alpha)$ to $\dot{f}(j)$
2. $q_{j,\alpha} \leq p_j \vee [q_{j,\alpha}] \cap [p_j] = \emptyset$.

Let E_j be a club disjoint from S_j . Because κ is weakly compact there exists an inaccessible $\lambda_j > \beta_j$ such that $\{q_{j,\alpha} \cap 2^{<\lambda_j} : \alpha < \lambda_j\}$ is predense in \mathbb{Q}_{λ_j} .

Let

$$H = \{\eta \in p_j \cap 2^{\lambda_j} : (\exists \alpha < \lambda_j) \eta \in [q_{j,\alpha} \cap 2^{<\lambda_j}]\}.$$

For $\eta \in H$ find $\alpha < \lambda_j$ such that $\eta \in [q_{j,\alpha} \cap 2^{<\lambda_j}]$ and define $r_{j,\eta} = q_{j,\alpha}^{[\eta]}$. Clearly $r_{j,\eta} \leq q_{j,\alpha}$ hence $r_{j,\eta}$ forces a value to $\dot{f}(j)$.

Let $r_{j,\eta}$ be witnessed by $(\eta, S_{j,\eta}, \vec{\Lambda}_{j,\eta})$ and let $E_{j,\eta}$ be a club disjoint from $S_{j,\eta}$. We define:

- (a) $p_i = \bigcup_{\eta \in H} r_{j,\eta}$
 (b) $S_i = (S_j \cap \lambda_j) \cup \{\lambda_j\} \cup \bigcup_{\eta \in H} (S_{j,\eta} \setminus (\lambda_j + 1))$.
 (c) $\vec{\Lambda}_i = \langle \Lambda_{i,\lambda} : \lambda \in S_i \rangle$ where

$$\Lambda_{i,\lambda} = \begin{cases} \bigcup \{ \Lambda_{j,\eta,\lambda} : \eta \in H \wedge \lambda \in S_{j,\eta} \} & \lambda > \lambda_j \\ \Lambda_{j,\lambda} & \lambda < \lambda_j \\ \{ \{ q_{j,\alpha} \cap 2^{<\lambda_j} : \alpha < \lambda_j \} \} & \lambda = \lambda_j \end{cases}$$

- (d) Let $E_i = E_j \cap \bigcap_{\eta \in H} (E_{j,\eta} \setminus (\lambda_j + 1))$.
 (e) Let $\beta_j = \min(E_i \setminus \lambda_j + 1)$.

For i limit let $p_i = \bigcap_{j < i} p_j$ and $\beta_i = \sup_{j < i} \beta_j$. Let $S_i = \bigcup_{j < i} S_j$ and for $\delta \in S_i$ let $\Lambda_{i,\delta} = \bigcup_{j < i} \Lambda_{j,\delta}$. By construction $(\text{tr}(p), S_i, \vec{\Lambda}_i)$ is a witness for p_i . In particular note that $S_i \cap \beta_i$ is not stationary in β_i because $\{\beta_j : j < i\}$ is a club disjoint from $S_i \cap \beta_i$.

Finally for $j < \kappa$ we have by construction $p_\kappa \Vdash \dot{f}(j) \leq \sup_{\alpha < \lambda_j} \gamma(j, \alpha) = g(j)$. \square

1.2 The Generalized Null Ideal

Definition 1.2.1. For inaccessible κ we now define ideals on 2^κ as follows:

- For $\mathcal{J} \subseteq \mathbb{Q}_\kappa$ we define

$$\text{set}_1(\mathcal{J}) = \bigcup_{p \in \mathcal{J}} [p], \quad \text{set}_0(\mathcal{J}) = 2^\kappa \setminus \text{set}_1(\mathcal{J}).$$

- For a collection Λ of subsets of \mathbb{Q}_κ we define

$$\text{set}_1(\Lambda) = \bigcap_{\mathcal{J} \in \Lambda} \text{set}_1(\mathcal{J}), \quad \text{set}_0(\Lambda) = 2^\kappa \setminus \text{set}_1(\Lambda).$$

Definition 1.2.2. For $A \subseteq 2^\kappa$:

1. $A \in \text{wid}(\mathbb{Q}_\kappa)$ iff there is a predense set $\mathcal{C} \subseteq \mathbb{Q}_\kappa$ such that $A \subseteq \text{set}_0(\mathcal{C})$.
 Equivalently, $A \in \text{wid}(\mathbb{Q}_\kappa)$ iff

$$(\forall p \in \mathbb{Q}_\kappa)(\exists q \in \mathbb{Q}_\kappa) q \leq p \text{ and } [q] \cap A = \emptyset$$

(We will discuss the ideal $\text{wid}(\mathbb{Q}_\kappa)$ in section 3, for “equivalently” see in particular 3.1.3.)

2. $\text{id}(\mathbb{Q}_\kappa)$ is the \leq_κ -closure of $\text{wid}(\mathbb{Q}_\kappa)$:

$A \in \text{id}(\mathbb{Q}_\kappa)$ iff A can be covered by the union of at most κ many sets in $\text{wid}(\mathbb{Q}_\kappa)$.

Equivalently, $A \in \text{id}(\mathbb{Q}_\kappa)$ iff there is a family Λ of κ many predense sets such that $A \subseteq \text{set}_0(\Lambda)$.

Theorem 1.2.3 ((Shelah 2017, 3.2)). *Let $A \subseteq 2^\kappa$. Then $A \in \text{id}(\mathbb{Q}_\kappa)$ iff there exists a κ -Borel set $\mathbf{B} \subseteq 2^\kappa$ such that $A \subseteq \mathbf{B}$ and*

$$\mathbb{Q}_\kappa \Vdash \dot{\eta} \notin \mathbf{B}$$

where $\dot{\eta}$ is the canonical generic κ -real added by \mathbb{Q}_κ .

[More explicitly, we should say that there is a κ -Borel code c in \mathbf{V} such that the corresponding Borel set \mathcal{B}_c contains A ($A \subseteq \mathcal{B}_c$) and that in the \mathbb{Q}_κ -extension, η will not be in the Borel set \mathcal{B}_c , computed in the extension: $\mathbb{Q}_\kappa \Vdash \dot{\eta} \notin \mathcal{B}_c$.]

Proof. By 1.2.4 and 1.2.5. □

Lemma 1.2.4 ((Shelah 2017, 3.2)). *Let $A \subseteq 2^\kappa$. If there exists a κ -Borel set \mathbf{B} such that $A \subseteq \mathbf{B}$ and $\mathbb{Q}_\kappa \Vdash \dot{\eta} \notin \mathbf{B}$ then $A \in \text{id}(\mathbb{Q}_\kappa)$.*

Proof. Let $\mathbf{B} \subseteq 2^\kappa$ be a κ -Borel set such that $\mathbb{Q}_\kappa \Vdash \dot{\eta} \notin \mathbf{B}$. Let $(T \subseteq \kappa^{<\omega}, \vec{\mathbf{B}})$ be a Borel code for \mathbf{B} (see 1.2.6 but to make the proof less stressful we allow complements and intersections instead of complements of unions). That is:

- (1) T is a subtree of $\kappa^{<\omega}$ with no infinite branch.
- (2) For $\rho \in T$ we have either
 - (i) $\text{suc}_T(\rho) = \emptyset$ or
 - (ii) $\text{suc}_T(\rho) = \{\rho \frown 0\}$ or
 - (iii) $\text{suc}_T(\rho) = \{\rho \frown i : i < \kappa\}$.
- (3) $\vec{\mathbf{B}} = \langle \mathbf{B}_\rho : \rho \in T \rangle$ and for \mathbf{B}_ρ is a Borelset for $\rho \in T$.
- (4) $\mathbf{B}_{\langle \rangle} = \mathbf{B}$.
- (5) If $\text{suc}_T(\rho) = \emptyset$ then

$$\mathbf{B}_\rho = \{\eta \in 2^\kappa : \eta(i_\rho) = c_\rho\}$$

for some $i_\rho < \kappa, c_\rho < 2$.

(6) If $\text{suc}_T(\rho) = \{\rho \frown 0\}$ then $\mathbf{B}_\rho = 2^\kappa \setminus \mathbf{B}_{\rho \frown 0}$.

(7) If $\text{suc}_T(\rho) = \{\rho^i : i < \kappa\}$ then

$$\mathbf{B}_\rho = \bigcap_{i < \kappa} \mathbf{B}_{\rho \frown i}.$$

For $\rho \in T$ we inductively construct \mathcal{I}_ρ, t_ρ such that:

- (a) \mathcal{I}_ρ is a maximal antichain of \mathbb{Q}_κ .
- (b) $t_\rho : \mathcal{I}_\rho \rightarrow 2$.
- (c) $t_\rho(p) = 0 \Rightarrow p \Vdash \text{“}\dot{\eta} \notin \mathbf{B}_\rho\text{”}$ and $t_\rho(p) = 1 \Rightarrow p \Vdash \text{“}\dot{\eta} \in \mathbf{B}_\rho\text{”}$.
- (d) If $|\text{suc}_T(\rho)| = 0$, $p \in \mathcal{I}_\rho$ then $\text{lg}(\text{tr}(p)) > i_\rho$.
- (e) If $|\text{suc}_T(\rho)| = 1$ then $\mathcal{I}_\rho = \mathcal{I}_{\rho \frown 0}$ and for $p \in \mathcal{I}_\rho$ we have $t_{\rho \frown 0}(p) = 1 - t_\rho(p)$.
- (f) If $\text{suc}_T(\rho)$ is infinite, $p \in \mathcal{I}_\rho$, $t_\rho(p) = 0$, then $p \Vdash \text{“}\dot{\eta} \notin \mathbf{B}_{\rho \frown i}\text{”}$ for some $i < \kappa$.
- (g) If $\rho \leq \psi \in T$ and $q \in \mathcal{I}_\psi$ then there exists a unique $p \in \mathcal{I}_\rho$ such that $p \leq q$.

[Note that the construction is not strictly inductive. If ρ has only one successor then we may need to look at a successor of ρ to satisfy (f) and then use (e) to push the work down. But it should be clear that we can easily construct \mathcal{I}_ρ, t_ρ as required.]

Let $Y = \bigcap_{\rho \in T} \text{set}_1(\mathcal{I}_\rho)$ and by definition $2^\kappa \setminus Y \in \text{id}_2(\mathbb{Q}_\kappa)$. We claim that for each $\rho \in T$, $\nu \in Y$ we have

$$\nu \in \mathbf{B}_\rho \Leftrightarrow (\exists p \in \mathcal{I}_\rho) \nu \in [p] \wedge t_\rho(p) = 1.$$

Proof by induction on T , starting from the leaves.

Case 1: $|\text{suc}_T(\rho)| = 0$.

There exists a unique $p \in \mathcal{I}_\rho$ such that $\nu \in [p]$ (remember 1.1.12). By (5) and (d) we have

$$\nu \in \mathbf{B}_\rho \Leftrightarrow \text{tr}(p)(i_\rho) = c_\rho \Leftrightarrow t_\rho(p) = 1.$$

Case 2: $|\text{suc}_T(\rho)| = 1$.

Let $p \in \mathcal{I}_\rho = \mathcal{I}_{\rho \frown 0}$ be the unique condition such that $\nu \in [p]$. Then

$$\nu \in \mathbf{B}_\rho \Leftrightarrow \nu \notin \mathbf{B}_{\rho \frown 0} \Leftrightarrow t_{\rho \frown 0}(p) = 0 \Leftrightarrow t_\rho(p) = 1.$$

Case 3: $\text{suc}_T(\rho)$ is infinite.

Let $p \in \mathcal{I}_\rho$ be the unique condition such that $\nu \in [p]$.

- Case 3a: $t_\rho(p) = 0$.

By (f) there exists $\psi = \rho \hat{\ } i$ such that $p \Vdash \dot{\eta} \notin B_\psi$. Let $q \in \mathcal{I}_\psi$ be the unique condition such that $\nu \in [q]$. By (g) we have $q \leq p$ hence $t_\psi(q) = 0$. By induction hypothesis this implies $\nu \notin B_\psi$ hence $\nu \notin B_\rho$.

- Case 3a: $t_\rho(p) = 1$.

Similarly.

Finally by our assumption $\mathbb{Q}_\kappa \Vdash \dot{\eta} \notin \mathbf{B} = \mathbf{B}_\emptyset$ we have $t_\emptyset(p) = 0$ for all $p \in \mathcal{I}_\emptyset$. Therefore $Y \cap \mathbf{B} = \emptyset$ and $\mathbf{B} \in \text{id}_2(\mathbb{Q}_\kappa)$. \square

Lemma 1.2.5. *Let $A \in \text{id}(\mathbb{Q}_\kappa)$. Then there exists a κ -Borel set \mathbf{B} such that $A \subseteq \mathbf{B}$ and $\mathbb{Q}_\kappa \Vdash \dot{\eta} \notin \mathbf{B}$.*

Proof. Let $\mathcal{I} = \{\mathcal{I}_i : i < \kappa\}$ be a family of maximal antichains of \mathbb{Q}_κ witnessing $A \in \text{id}(\mathbb{Q}_\kappa)$, i.e.

$$2^\kappa \setminus A \supseteq \text{set}_1(\mathcal{I}) = \bigcap_{i < \kappa} \bigcap_{p \in \mathcal{I}_i} [p].$$

It is easy to check that for any $p \in \mathbb{Q}_\kappa$ the set $[p] \subseteq 2^\kappa$ is closed. Remember that \mathbb{Q}_κ satisfies the κ^+ -c.c. (1.1.13) hence $|\mathcal{I}_i| \leq \kappa$ and thus $\text{set}_1(\mathcal{I})$ is the intersection of κ -many closed sets.

It remains to show that $\mathbb{Q}_\kappa \Vdash \dot{\eta} \in \text{set}_1(\mathcal{I})$. Let $p \in \mathbb{Q}_\kappa$ be arbitrary and let $i < \kappa$. Find $p' \in \mathcal{I}_i$ such that p, p' are compatible and let $p'' = p \wedge p'$. Now $p'' \Vdash \dot{\eta} \in \mathcal{I}_i$. Clearly this suffices. \square

Definition 1.2.6. For every $\eta \in 2^{<\kappa}$ we write $[\eta]$ for the set of $x \in 2^\kappa$ extending η ; these are the basic clopen sets of the box product topology (i.e., the $<\kappa$ -box product topology).

Let \mathbf{Borel}_κ be the smallest family containing all clopen sets which is closed under complements and unions/intersections of at most κ -many sets. If $\mathbf{B} \in \mathbf{Borel}_\kappa$ then we call \mathbf{B} a κ -Borel set.

A *Borel code* is a well-founded tree (with a unique root) with κ many nodes whose leaves are labeled with elements of $2^{<\kappa}$; this assigns basic clopen sets to every leaf. This assignment can be naturally extended to the whole tree: if the successors of a node ν are labeled with set $(\mathbf{B}_i : i \in \kappa)$, then ν is labeled with $2^\kappa \setminus \bigcup_{i < \kappa} \mathbf{B}_i$.

(Equivalently, a Borel code is an infinitary formula in the propositional language $L_{<\kappa^+}$, where the propositional variables are identified with the basic clopen sets.)

If c is a Borel code, we write \mathcal{B}_c for the Borel set associated with it (i.e., the value of the assignment described above on the root of the tree c).

Fact 1.2.7. Let \mathbf{V}, \mathbf{W} be two universes. Let $\eta \in 2^\kappa \cap \mathbf{V} \cap \mathbf{W}$ and let c be a Borel code in $\mathbf{V} \cap \mathbf{W}$. Then it follows from an easy inductive argument on the rank of c :

$$\mathbf{V} \models \eta \in \mathcal{B}_c \quad \Leftrightarrow \quad \mathbf{W} \models \eta \in \mathcal{B}_c.$$

This fact will allow us to speak about Borel sets when we should officially speak about Borel codes.

Definition 1.2.8. Let $S \subseteq S_{\text{inc}}^\kappa$ be nowhere stationary. By $\mathbb{Q}_{\kappa, S}$ we mean the forcing that is inductively defined similarly to \mathbb{Q}_κ but additionally for $\delta \in S_{\text{inc}}^{\kappa+1}$ we require $p \in \mathbb{Q}_{\delta, S \cap \delta}$ iff:

1. $p \in \mathbb{Q}_\delta$.
2. p is witnessed by some $(\tau, W, \vec{\Lambda})$ such that $W \subseteq S \cap \delta$.

Note that this definition is different from 3.3.8.

1.3 Quantifiers and Rational Translates

Definition 1.3.1. Let μ be a regular cardinal. We use the following notation:

- Let $A, B \subseteq \mu$. We say $A \subseteq_\mu^* B$ if there exists $\zeta < \mu$ such that $A \setminus \zeta \subseteq B$. If μ is clear from the context we write $A \subseteq^* B$.
- “ $(\exists^\mu \epsilon) \phi(\epsilon)$ ” is an abbreviation for “ $\{\epsilon < \mu : \phi(\epsilon)\}$ is cofinal in μ ”. Similarly “ $(\forall^\mu \epsilon) \phi(\epsilon)$ ” is an abbreviation for “ $\{\epsilon < \mu : \neg\phi(\epsilon)\}$ is bounded in μ ”. If μ is clear from the context we write \exists^∞ and \forall^∞ .

Note that these quantifiers satisfy the usual equivalence

$$(\exists^\mu \epsilon) \phi(\epsilon) \quad \Leftrightarrow \quad \neg(\forall^\mu \epsilon) \neg\phi(\epsilon).$$

- For $\eta, \nu \in 2^\mu$ (or μ^μ) define
 1. $\eta =_\mu^* \nu \quad \Leftrightarrow \quad (\forall^\infty i < \mu) \eta(i) = \nu(i)$.
 2. $\eta \leq_\mu^* \nu \quad \Leftrightarrow \quad (\forall^\infty i < \mu) \eta(i) \leq \nu(i)$.

and again we may just write $\eta =^* \nu$ and $\eta \leq^* \nu$.

Definition 1.3.2. We define:

1. $\mathfrak{b}_\kappa = \min\{|B| : B \subseteq \kappa^\kappa \wedge (\forall \eta \in \kappa^\kappa)(\exists \nu \in B) \neg(\nu \leq^* \eta)\}$.
2. $\mathfrak{d}_\kappa = \min\{|D| : D \subseteq \kappa^\kappa \wedge (\forall \eta \in \kappa^\kappa)(\exists \nu \in D) \eta \leq^* \nu\}$.

Definition 1.3.3. • For $p \in \mathbb{Q}_\kappa$, $\alpha < \kappa$, $\nu \in 2^\alpha$, and $\eta \in p \cap 2^\alpha$ (typically $\text{tr}(p) \leq \eta$) we let $p^{[\eta, \nu]}$ be the condition obtained from p by first removing all nodes not compatible with η , and then replacing η by ν :

$$p^{[\eta, \nu]} = \{\rho : \rho \leq \nu \vee ((\exists \varrho) \eta \frown \varrho \in p \wedge \rho = \nu \frown \varrho)\}$$

- For $\mathcal{J} \subseteq \mathbb{Q}_\kappa$, $\alpha < \kappa$, a permutation π of 2^α let

$$\mathcal{J}^{[\alpha, \pi]} = \{p^{[\eta, \nu]} : p \in \mathcal{J}, \eta \in (p \cap 2^\alpha), \nu = \pi(\eta)\}$$

- For a collection Λ of subsets of \mathbb{Q}_κ and $\alpha < \kappa$.

$$\Lambda^{[\alpha]} = \{\mathcal{J}^{[\alpha, \pi]} : \mathcal{J} \in \Lambda, \pi \text{ is a permutation of } 2^\alpha\}$$

Easily $|\Lambda^{[\alpha]}| \leq \kappa + |\Lambda|$. If $\Lambda^\alpha = \Lambda$ for all $\alpha < \kappa$ we say that Λ is *closed under rational translates*.

1.4 The Property $\text{Pr}(\cdot)$ and the Nowhere Stationary Ideal

Definition 1.4.1. $\text{Pr}(\kappa)$ means there exists $\Lambda = \{\Lambda_i : i < \kappa\}$ where $\Lambda_i \subseteq \mathbb{Q}_\kappa$ is a maximal antichain (or predense) such that for no $p \in \mathbb{Q}_\kappa$ we have

$$[p] \subseteq \text{set}_1(\Lambda) = \bigcap_{i < \kappa} \text{set}_1(\Lambda_i).$$

We define

$$S_{\text{pr}}^\kappa = \{\lambda \in S_{\text{inc}}^\kappa : \text{Pr}(\lambda)\}.$$

Lemma 1.4.2. *Let κ be Mahlo. Then*

$$X = \{\lambda < \kappa : \lambda \text{ is inaccessible but not Mahlo}\}$$

is a stationary subset of κ .

Proof. Towards contradiction assume X is not stationary and let $E \subseteq \kappa$ be a club disjoint from X . Note that $\lambda \in E \cap S_{\text{inc}} \Rightarrow \lambda$ is Mahlo. Let

$$\lambda = \min\{\text{acc}(E) \cap S_{\text{inc}}\}$$

and of course $\text{acc}(E) \subseteq E$ hence λ is Mahlo. Clearly $\lambda \cap E$ is a club of λ and because λ is Mahlo $S = \lambda \cap E \cap S_{\text{inc}}$ is stationary. Consider the function $f : \mu \in S \mapsto \sup(E \cap \mu)$ and note that by definition of λ we have $f(\mu) < \mu$, i.e. f is regressive. Of course λ is regular, uncountable use Fodor's lemma to find $S' \subseteq S$ such that S' is a stationary subset of λ and $f \upharpoonright S' \equiv \gamma$. In particular S' is unbounded hence $(\gamma, \lambda) \cap E = \emptyset$. Contradiction to $\lambda \in \text{acc}(E)$. \square

Lemma 1.4.3 ((Shelah 2017, 4.4)).

1. If κ is inaccessible but not Mahlo then $\text{Pr}(\kappa)$.
2. If κ is weakly compact then $\neg \text{Pr}(\kappa)$.
3. If $\kappa = \sup(S_{\text{inc}}^\kappa)$ then $\kappa = \sup(S_{\text{pr}}^\kappa)$.
4. If κ is Mahlo then S_{pr}^κ is a stationary subset of κ . \square

Proof.

1. Let $E \subseteq \kappa$ be a club disjoint from S_{inc}^κ and let $\langle \alpha_i : i < \kappa \rangle$ be an increasing enumeration of E . For $i < \kappa$ let

$$\mathcal{I}_i = \{[\nu \widehat{\ } 0] : \text{lg}(\nu) = \alpha_j, j > i\} \subseteq \mathbb{Q}_\kappa$$

and clearly each \mathcal{I}_i is open dense. We claim that $\{\mathcal{I}_i : i < \kappa\}$ witnesses $\text{Pr}(\kappa)$.

Let $p \in \mathbb{Q}_\kappa$ and find $i^* < \kappa$ such that $\alpha_{i^*} > \text{lg}(\text{tr}(p))$. By induction on $i \in [i^*, \kappa)$ find $\nu_i \in 2^{\alpha_i} \cap p$ such that

$$i^* \leq j < i \Rightarrow \nu_j \widehat{\ } 1 \trianglelefteq \nu_i.$$

[Why possible? Trivial for successor. For limit remember the choice of E .]

Let $\eta = \bigcup_{i \in [i^*, \kappa)} \nu_i$. Clearly $\eta \in [p]$ but $\eta \notin \text{set}_1(\{\mathcal{I}_i : i < \kappa\})$.

2. Work as in 1.1.14.

3. By (1).

4. By (1) and 1.4.2. □

Discussion 1.4.4. A similar argument as 1.4.3 shows that for κ not Mahlo \mathbb{Q}_κ adds a Cohen real. This gives a lower bound for the consistency strength of “ \mathbb{Q}_κ is κ^κ -bounding”.

Theorem 1.4.5 ((Shelah 2017, 4.7, 4.8)). *Let $p \in \mathbb{Q}_\kappa$, $\lg(\text{tr}(p)) < \alpha < \beta \leq \kappa$. Then there exists $q \leq p$ such that:*

(a) $\text{tr}(p) = \text{tr}(q)$.

(b) $S_p \setminus (\alpha, \beta) = S_q \setminus (\alpha, \beta)$ and $\lambda \in S_q \setminus (\alpha, \beta) \Rightarrow \Lambda_{p,\lambda} = \Lambda_{q,\lambda}$.

(c) $S_q \cap (\alpha, \beta) \subseteq S_{\text{pr}}^\kappa$.

In particular for $\beta = \kappa$ we get

$$\{p \in \mathbb{Q}_\kappa : S_p \in \mathbf{nst}_\kappa^{\text{pr}}\}$$

is a dense subset of \mathbb{Q}_κ .

Proof. By induction on β .

Case 1: $\alpha = \beta \vee \alpha = \beta + 1$.

Trivial because $(\alpha, \beta) = \emptyset$.

Case 2: $\beta = \sup(\beta \cap S_p) + 1$, $\sup(\beta \cap S_p) \notin S_p \setminus S_{\text{pr}}^\kappa$.

Let $\gamma = \sup(\beta \cap S_p)$ and use the induction hypothesis for p and (α, γ) to get q . Now q also satisfies the demands for (α, β) because either $\gamma \notin S_p$ or $\gamma \in S_{\text{pr}}^\kappa$.

Case 3: $\beta > \sup(\beta \cap S_p) + 1$.

Let $\gamma = \sup(\beta \cap S_p) + 1$ and use the induction hypothesis for p and (α, γ) to get q . Again easily q satisfies the demands for (α, β) .

Case 4: $\beta = \sup(\beta \cap S_p)$.

So β is limit and let $\beta^* = \text{cf}(\beta)$ and let $\langle \alpha_i : i \leq \beta^* \rangle$ be an increasing, continuous sequence such that:

1. $\alpha_0 = \alpha$.

2. $\alpha_{\beta^*} = \beta$.

3. For every $i < \beta^*$ we have $\alpha_i \notin S_p$. (Remember S_p is not stationary in β .)

For $i \leq \beta^*$ find $p_i \in \mathbb{Q}_\kappa$ such that:

1. $p_0 = p$.
2. $\text{tr}(p_i) = \text{tr}(p)$
3. $S_{p_i} \setminus (\alpha, \alpha_i) = S_p \setminus (\alpha, \alpha_i)$ and $\lambda \in S_{p_i} \setminus (\alpha, \alpha_i) \Rightarrow \Lambda_{p_i, \lambda} = \Lambda_{p, \lambda}$.
4. If $j < i$ then $p_i \leq p_j$, $S_{p_i} \setminus (\alpha_j, \alpha_i) = S_{p_j} \setminus (\alpha_j, \alpha_i)$ and $\lambda \in S_{p_i} \setminus (\alpha_j, \alpha_i) \Rightarrow \Lambda_{p_i, \lambda} = \Lambda_{p_j, \lambda}$.
5. If $i = j + 1$ then $S_{p_i} \cap (\alpha_j, \alpha_i) \subseteq S_{\text{pr}}^\kappa$.

[How can we carry out this construction? For $i = j + 1$ use the induction hypothesis with $p_j, (\alpha_j, \alpha_i)$. For i limit remember that $\{\alpha_j : j < i\}$ is by construction a club disjoint from S_{p_i} .]

Now $q = p_\kappa$ is as required.

Case 5: $\beta = \delta + 1$, $\delta \in S_p \setminus S_{\text{pr}}^\kappa$, $\delta > \alpha$.

So $\neg \text{Pr}(\delta)$. Find $p^* \in \mathbb{Q}_\delta$ such that:

1. $\text{tr}(p^*) = \langle \rangle$.
2. $S_{p^*} \subseteq (\alpha, \delta)$.
3. $[p] \subseteq \text{set}_1(\Lambda_{p, \delta})$.

[Why possible? Use rational translates.]

Now define $q \in \mathbb{Q}_\kappa$ by:

1. $\text{tr}(q) = \text{tr}(p)$.
2. $S_q = S_p \setminus \{\delta\} \cup S_{p^*}$.
3. For $\lambda \in S_q$ let

$$\Lambda_{q, \lambda} = \begin{cases} \Lambda_{p, \lambda} & \lambda \in S_p \setminus S_{p^*} \\ \Lambda_{p^*, \lambda} & \lambda \in S_{p^*} \setminus S_p \\ \Lambda_{p, \lambda} \cup \Lambda_{p^*, \lambda} & \lambda \in S_p \cap S_{p^*}. \end{cases}$$

Now because $\delta \notin S_q$ we can work as in case 2 or case 3. □

Definition 1.4.6. Define ideals:

$$\begin{aligned}\mathbf{nst}_\kappa &= \{S \subseteq S_{\text{inc}}^\kappa : S \text{ is nowhere stationary}\} \\ \mathbf{nst}_\kappa^{\text{pr}} &= \{S \subseteq S_\kappa^{\text{pr}} : S \text{ is nowhere stationary}\}\end{aligned}$$

The order on these ideals is \subseteq^* , i.e. set-inclusion modulo bounded subsets. Note that by 1.4.3(4), for every Mahlo cardinal κ the set S_{pr}^κ is stationary; so κ Mahlo is sufficient for $\mathbf{nst}_\kappa^{\text{pr}}$ to be proper (i.e., $\kappa \notin \mathbf{nst}_\kappa^{\text{pr}}$).

1.5 Ideals and Strengthened Galois-Tukey Connections

Definition 1.5.1. Let X be a set and let $\mathbf{i} \subseteq \mathfrak{P}(X)$ be an ideal. The equivalence relation $\sim_{\mathbf{i}}$ on $\mathfrak{P}(X)$ is defined by $A \sim_{\mathbf{i}} B \Leftrightarrow A \Delta B \in \mathbf{i}$. We write $X/\sim_{\mathbf{i}}$ for the set of equivalence classes.

If \mathbf{j} is an ideal containing \mathbf{i} , we write \mathbf{j}/\mathbf{i} for the naturally induced ideal on X/\mathbf{i} :

$$\mathbf{j}/\mathbf{i} := \{A/\sim_{\mathbf{i}} \mid A \in \mathbf{j}\}.$$

Definition 1.5.2. Let X be a set and let $\mathbf{i} \subseteq \mathfrak{P}(X)$ be an ideal containing all singletons. Then:

$$\begin{aligned}\text{add}(\mathbf{i}) &:= \min\{|\mathcal{A}| : \mathcal{A} \subseteq \mathbf{i} \wedge \cup \mathcal{A} \notin \mathbf{i}\} \\ \text{cov}(\mathbf{i}) &:= \min\{|\mathcal{A}| : \mathcal{A} \subseteq \mathbf{i} \wedge \cup \mathcal{A} = X\} \\ \text{non}(\mathbf{i}) &:= \min\{|A| : A \in \mathfrak{P}(X) \setminus \mathbf{i}\} \\ \text{cf}(\mathbf{i}) &:= \min\{|\mathcal{A}| : \mathcal{A} \subseteq \mathbf{i} \wedge (\forall B \in \mathbf{i})(\exists A \in \mathcal{A}) B \subseteq A\}.\end{aligned}$$

For two ideals $\mathbf{i}, \mathbf{j} \subseteq \mathfrak{P}(X)$ let

$$\begin{aligned}\text{add}(\mathbf{i}, \mathbf{j}) &:= \min\{|\mathcal{A}| : \mathcal{A} \subseteq \mathbf{i} \wedge \cup \mathcal{A} \notin \mathbf{j}\} \\ \text{cf}(\mathbf{i}, \mathbf{j}) &:= \min\{|\mathcal{A}| : \mathcal{A} \subseteq \mathbf{j} \wedge (\forall B \in \mathbf{i})(\exists A \in \mathcal{A}) B \subseteq A\}.\end{aligned}$$

Fact 1.5.3. Let X be a set and let $\mathbf{i} \subseteq \mathfrak{P}(X)$ be an ideal. Then

- (a) $\text{add}(\mathbf{i}) \leq \text{cov}(\mathbf{i}) \leq \text{cf}(\mathbf{i})$.
- (b) $\text{add}(\mathbf{i}) \leq \text{non}(\mathbf{i}) \leq \text{cf}(\mathbf{i})$.

Fact 1.5.4. Let X be a set and let $\mathbf{i}^- \subseteq \mathbf{i} \subseteq \mathfrak{P}(X)$ be two ideals. Then:

(a) $\text{add}(\mathbf{i}) \leq \text{add}(\mathbf{i}^-, \mathbf{i})$.

(b) $\text{add}(\mathbf{i}^-) \leq \text{add}(\mathbf{i}^-, \mathbf{i})$.

(c) $\text{cf}(\mathbf{i}^-, \mathbf{i}) \leq \text{cf}(\mathbf{i})$.

(d) $\text{cf}(\mathbf{i}^-, \mathbf{i}) \leq \text{cf}(\mathbf{i}^-)$. □

Fact 1.5.5. Let X be a set and let $\mathbf{i}^- \subseteq \mathbf{i} \subseteq \mathfrak{P}(X)$ be two ideals. Then:

(a) $\text{add}(\mathbf{i}) \geq \min\{\text{add}(\mathbf{i}^-), \text{add}(\mathbf{i}/\mathbf{i}^-)\}$.

(b) $\text{cf}(\mathbf{i}) \leq \text{cf}(\mathbf{i}^-) + \text{cf}(\mathbf{i}/\mathbf{i}^-)$.

Definition 1.5.6. Consider ideals $\mathbf{i}^- \subseteq \mathbf{i} \subseteq \mathfrak{P}(X)$, $\mathbf{j} \subseteq \mathfrak{P}(U)$. We call maps

1. $\phi^+ : \mathbf{i} \rightarrow \mathbf{j}$

2. $\phi^- : \mathbf{j} \rightarrow \mathbf{i}^-$

a *strengthened Galois-Tukey connection* if for all $A \in \mathbf{i}, B \in \mathbf{j}$:

$$\phi^-(B) \subseteq A \quad \Rightarrow \quad B \subseteq \phi^+(A).$$

Discussion 1.5.7. Strengthened Galois-Tukey connections are a special case of what is called a *generalized Galois-Tukey connection* in (Vojtáš 1993) and a *morphism* in (Blass 2010).

Lemma 1.5.8. Consider $\mathbf{i}^- \subseteq \mathbf{i} \subseteq \mathfrak{P}(X)$, $\mathbf{j} \subseteq \mathfrak{P}(U)$ and let ϕ^-, ϕ^+ be a strengthened Galois-Tukey connection between them. Then

(a) $\text{add}(\mathbf{i}^-, \mathbf{i}) \leq \text{add}(\mathbf{j})$.

(b) $\text{cf}(\mathbf{i}^-, \mathbf{i}) \leq \text{cf}(\mathbf{j})$.

Proof.

(a) Let $\langle B_\zeta : \zeta < \mu < \text{add}(\mathbf{i}^-, \mathbf{i}) \rangle$ be a family of $B_\zeta \in \mathbf{j}$. Find $A \in \mathbf{i}$ such that $\bigcup_{\zeta < \mu} \phi^-(B_\zeta) \subseteq A$ thus $\bigcup_{\zeta < \mu} B_\zeta \subseteq \phi^+(A)$.

(b) Let $\langle A_\zeta : \zeta < \mu = \text{cf}(\mathbf{i}^-, \mathbf{i}) \rangle$ be a family of $A_\zeta \in \mathbf{i}$ cofinal for \mathbf{i}^- . Then for $B \in \mathbf{j}$ we can find $\zeta < \mu$ such that $\phi^-(B) \subseteq A_\zeta$ thus $B \subseteq \phi^+(A_\zeta)$, i.e. $\langle \phi^+(A_\zeta) : \zeta < \mu \rangle$ is a cofinal family of \mathbf{j} . □

1.6 Miscellaneous

Definition 1.6.1. Let $X \subseteq \kappa$. Then

1. $\text{acc}(X) := \{\alpha < \kappa : (\exists Y \subseteq X) \sup(Y) = \alpha\}$.
2. $\text{nacc}(X) := X \setminus \text{acc}(X)$.

Definition 1.6.2. Let $\text{id}(\text{Cohen}_\kappa)$ be the ideal of meager subsets of 2^κ .

CHAPTER 2

Tools

In this section we introduce/recall several concepts and tools that will be useful later. In particular, we give sufficient conditions for the following properties to be preserved in iterations.

- **2.1:** Closure properties, such as strategic closure.
- **2.2:** Stationary Knaster, a property that is intermediate between the κ^+ -chain condition and κ -centeredness; this property is preserved in $<\kappa$ -support iterations.
- **2.3:** a version of κ -centeredness.
(Also, similarly to the classical case, sufficiently centered forcing notions will not add random reals, and will neither decrease $\text{non}(\mathbb{Q}_\kappa)$ nor increase $\text{cov}(\mathbb{Q}_\kappa)$.)
- **2.4 and 2.5:** A property defined by a game, which allows fusion arguments in iterations with κ -support, and implies properness and κ^κ -bounding.

2.1 Closure

Definition 2.1.1. Let \mathbb{Q} be a forcing notion. We say that \mathbb{Q} is α -closed if for every descending sequence $\langle p_i : i < i^* \rangle$ of length $i^* < \alpha$ (with all $p_i \in \mathbb{Q}$) there is a lower bound in \mathbb{Q} , i.e. there exists $q \in \mathbb{Q}$ such that for every $i < i^*$ the condition q is stronger than p_i .

To avoid confusion we may write $<\alpha$ -closed.

Definition 2.1.2. Let \mathbb{Q} be a forcing notion. We say that \mathbb{Q} is α -directed closed if every directed set $D \subseteq \mathbb{Q}$ of cardinality $< \alpha$ has a lower bound. (A set D is called directed if any two elements of D are compatible and moreover have a lower bound in D .)

To avoid confusion we may write $<\alpha$ -directed closed.

Remark 2.1.3. It is customary to write κ -closed and κ -c.c. for $<\kappa$ -closed and $<\kappa$ -c.c., respectively.

An iteration in which the domains of the conditions have size $\leq \kappa$ should logically be called “iterations with $<\kappa^+$ -supports”, or abbreviated “ κ^+ -supports”. Convention, however, dictates that such iterations are called “iterations with κ -supports”; we will follow this convention.

Most of our forcing iterations will have $<\kappa$ -support and behave similarly to finite support iterations in the classical case; some of our iterations will have κ -support, in analogy to countable support iterations.

Definition 2.1.4. Let \mathbb{Q} be a forcing notion and let $q \in \mathbb{Q}$. Define the game $\mathfrak{C}_\kappa(\mathbb{Q}, q)$ between two players White and Black taking turns playing conditions of \mathbb{Q} stronger than q , i.e. first White plays $p_0 \leq q$, then Black plays a condition $p'_0 \in \mathbb{Q}$, then White plays $p_1 \in \mathbb{Q}$ and so on. The game continues for κ -many turns and note that White plays first in limit steps. The rules of the game are:

1. For $i < \kappa$ we require $p'_i \leq p_i$.
2. For $i < j < \kappa$ we require $p_j \leq p'_i$.

White wins if he can follow the rules until the end.

We say that \mathbb{Q} is κ -strategically closed if White has a winning strategy for $\mathfrak{C}_\kappa(\mathbb{Q}, q)$ for every $q \in \mathbb{Q}$.

Fact 2.1.5. Let \mathbb{Q} be a forcing notion. Consider the following statements:

- (a) \mathbb{Q} is $<\kappa$ -directed closed.
- (b) \mathbb{Q} is $<\kappa$ -closed.
- (c) \mathbb{Q} is κ -strategically closed.

Then: (a) \Rightarrow (b) \Rightarrow (c). \square

Fact 2.1.6. Let $\mathbb{P} = \langle \mathbb{P}_\alpha, \dot{\mathbb{Q}}_\alpha : \alpha < \delta \rangle$ be a forcing iteration with $<\lambda$ -support. If for every $\alpha < \delta$ we have $\mathbb{P}_\alpha \Vdash \text{“}\dot{\mathbb{Q}}_\alpha \Vdash \phi\text{”}$ then also $\mathbb{P} \Vdash \phi$ where $\phi \in \{ \text{“}<\kappa\text{-directed closed”}, \text{“}<\kappa\text{-closed”}, \text{“}\kappa\text{-strategically closed”} \}$ whenever $\lambda \geq \kappa$. In particular, these properties are preserved in $<\kappa$ -support iterations and in κ -support iterations. \square

2.2 Stationary Knaster, preservation in $<\kappa$ -support iterations

Discussion 2.2.1. To obtain independence results for the classical case ($\kappa = \omega$) we often use finite support iterations of c.c.c. forcing notions. Such iterations are useful due to the well known fact that their finite support limits will again satisfy the c.c.c.

In this section we will quote a parallel for the case of uncountable κ , first appearing in (Shelah 1978).

Definition 2.2.2. Let κ be a cardinal. Let \mathbb{Q} be a forcing notion. We say that \mathbb{Q} satisfies the stationary κ^+ -Knaster condition if for every $\{p_i : i < \kappa^+\} \subseteq \mathbb{Q}$ there exists a club $E \subseteq \kappa^+$ and a regressive function f on $E \cap S_\kappa^{\kappa^+}$ such that any $i, j \in E \cap S_\kappa^{\kappa^+}$ we have that

$$f(i) = f(j) \quad \Rightarrow \quad p_i \not\perp p_j.$$

Fact 2.2.3. The stationary κ^+ -Knaster condition implies the κ^+ -chain condition.

Proof. By Fodor’s pressing down lemma the stationary κ^+ -Knaster condition implies that for every $\{p_i : i < \kappa^+\} \subseteq \mathbb{Q}$ there exists a stationary set $S \subseteq \kappa^+$ such for that any $i, j \in S$ the conditions p_i, p_j are compatible. \square

Definition 2.2.4. Let κ be a cardinal. Let \mathbb{Q} be a forcing notion. We say that \mathbb{Q} satisfies $(*_\kappa)$ if the following holds:

- (a) \mathbb{Q} satisfies the stationary κ^+ -Knaster condition.
- (b) Any decreasing sequence $\langle p_i : i < \omega \rangle$ of conditions of \mathbb{Q} has a greatest lower bound.
- (c) Any compatible $p, q \in \mathbb{Q}$ have a greatest lower bound.

(d) \mathbb{Q} does not add elements of $(\kappa^+)^{<\kappa}$ (e.g. \mathbb{Q} is strategically κ -closed.)

Lemma 2.2.5. *Let κ be a cardinal. Let \mathbb{Q} be a forcing notion such that:*

1. \mathbb{Q} satisfies the stationary κ^+ -Knaster condition.
2. \mathbb{Q}_κ is κ -strategically closed.

Then \mathbb{Q} does not collapse cardinals. □

Lemma 2.2.6. *Let \mathbb{Q} be a forcing notion that satisfies the κ^+ -c.c. and let \dot{C} be a \mathbb{Q} -name for a club of κ^+ in $\mathbf{V}^{\mathbb{Q}}$. Then there exists a club $D \in \mathbf{V}$ of κ^+ such that $\mathbb{Q} \Vdash \check{D} \subseteq \dot{C}$.*

Proof. For every $\alpha < \kappa$ let \dot{c}_α be a name for the α -th element of \dot{C} and let $\langle p_{\alpha,\zeta} : \zeta < \kappa \rangle$ be a maximal antichain such that each $\zeta < \kappa$ we have $p_{\alpha,\zeta} \Vdash \dot{c}_\alpha = c_{\alpha,\zeta}$ for some $c_{\alpha,\zeta} < \kappa^+$. Let $c_\alpha = \sup_{\zeta < \kappa} (c_{\alpha,\zeta})$ and define $f(\alpha) = c_\alpha$.

By induction we construct an enumeration $\langle d_\alpha : \alpha < \kappa^+ \rangle$ of the elements of D . For α limit simply let $d_\alpha = \sup_{\beta < \alpha} (d_\beta)$.

Given d_α we find $d_{\alpha+1} > d_\alpha$ as follows. Let $\langle \alpha_i : i < \omega \rangle$ be a sequence such that $\alpha_0 = d_\alpha$ and for each $j = i + 1$ we have $\alpha_j = f(i) + 1$.

Note that

$$\mathbb{Q} \Vdash \alpha \leq \dot{c}_\alpha \leq c_\alpha = f(\alpha) < f(\alpha) + 1$$

and let $d_{\alpha+1} = \sup_{i < \omega} \alpha_i$. Clearly $d_{\alpha+1} > d_\alpha$ and $\mathbb{Q} \Vdash \dot{d}_{\alpha+1} \in \dot{C}$. □

Lemma 2.2.7. *Let \mathbb{Q} be a forcing notion satisfying:*

- (b) *Any decreasing sequence $\langle p_i : i < \omega \rangle$ of conditions of \mathbb{Q} has a greatest lower bound.*
- (c) *Any compatible $p, q \in \mathbb{Q}$ have a greatest lower bound.*

Let $\vec{r} = \langle r_i : i < \omega \rangle$, $\vec{s} = \langle s_i : i < \omega \rangle$ be two decreasing sequences of conditions of \mathbb{Q} such that for all $i < \omega$ we have $r_i \not\leq s_i$. Let r, s be a greatest lower bounds for \vec{r}, \vec{s} respectively. Then $r \not\leq s$.

Proof. For $i < \omega$ use (c) and let $t_i = r_i \wedge s_i$. It is easy to see that $\vec{t} = \langle t_i : i < \omega \rangle$ is decreasing. If $i = j + 1$ then $t_i \leq r_j \wedge s_j = t_j$. Thus use (b) and let t be a lower bound for \vec{t} . Now check that t is a lower bound for both \vec{r} and \vec{s} . Hence $t \leq r, t \leq s$. □

Theorem 2.2.8. *Let κ be a cardinal. Let $\langle \mathbb{P}_\xi, \dot{\mathbb{Q}}_\xi : \xi < \delta \rangle$ be a $<\kappa$ -support iteration such that for every $\xi < \delta$*

$$\mathbb{P}_\xi \Vdash \dot{\mathbb{Q}}_\xi \text{ satisfies } (*_\kappa) \text{ from Definition 2.2.4.}$$

Then \mathbb{P}_δ satisfies the stationary κ^+ -Knaster condition.

Proof. We follow (Shelah 1978). Let $\{p_i : i < \kappa^+\} \subseteq \mathbb{P}_\delta$ and we are going to find E, f satisfying 2.2.2.

We inductively define $\langle p_i^n : i < \kappa^+, n < \omega \rangle$ and $\langle \dot{E}_\xi^n, f_\xi^n, a_\xi^n : \xi < \delta, n < \omega \rangle$ such that:

1. For $i < \kappa^+$ we have $p_i^0 = p_i$.
2. For $\zeta < \delta, n < \omega$ we have $\mathbb{P}_\zeta \Vdash \langle \dot{E}_\zeta^n, f_\zeta^n \rangle$ witness the stationary κ^+ -Knaster condition for $\langle p_i^n(\zeta) : i < \kappa^+ \rangle$. By 2.2.6 and an inductive argument we have without loss of generality $\dot{E}_\zeta^n = E_\zeta^n \in \mathbf{V}$.
3. For $i < \kappa^+, n < \omega$ we have $p_i^{n+1} \leq p_i^n$.
4. For $i < \kappa^+, n < \omega, \xi \in \text{supp}(p_i^n)$ we have $p_i^{n+1} \restriction \xi \Vdash \langle f_\xi^n(i) = a_\xi^n(i) \rangle$ for some $a_\xi^n(i) < i$. (Remember 2.2.4 (d)).

Now let $E_\xi = \bigcup_{n < \omega} E_\xi^n$ and remembering 2.2.4 (b) let p_i^ω be the greatest lower bound of $\langle p_i^n : n < \omega \rangle$. Let $\langle \xi_\alpha : \alpha < \kappa^+ \rangle$ be an enumeration of $X = \bigcup_{i < \kappa^+} \text{supp}(p_i^\omega)$. Let

$$E = \{i < \kappa^+ : (\forall \alpha < i) i \in E_{\xi_\alpha}\}$$

be the diagonal intersection “along X ”. For $i < \kappa^+$ let:

1. $\alpha_i = \min\{\gamma \leq i : (\forall \alpha < i) \xi_\alpha \in \text{supp}(p_i^\omega) \Rightarrow \alpha \leq \gamma\}$.
2. $\beta_i = \sup(\text{supp}(p_i^\omega))$.

Note that:

1. For $i \in S_\kappa^+$ we always have $\alpha_i < i$.
2. There exists a club $E' \subseteq \kappa^+$ such that for $j \in E'$ and $i < j$ we have $\beta_i < j$.

Define

$$f(i) = \ulcorner (\alpha_i, \langle a_{\xi_\alpha}^n(i) : \alpha < i, n < \omega \rangle) \urcorner$$

where $\ulcorner \cdot \urcorner : \kappa^+ \times (\kappa^+)^{<\kappa \times \omega} \rightarrow \kappa^+$ is a coding function. Let $E'' \subseteq E \cap E'$ be a club such that f is regressive on $E'' \cap S_\kappa^{\kappa^+}$ and we claim that f, E'' witness the stationary κ^+ -Knaster condition for $\langle p_i : i < \kappa^+ \rangle$.

Let $i, j \in E'' \cap S_\kappa^{\kappa^+}$, let $f(i) = f(j)$ and $i < j$ and we are going to show $p_i^\omega \not\leq p_j^\omega$. We claim exists r stronger than p_i^ω and p_j^ω with $r(\xi) = p_i^\omega(\xi) \wedge p_j^\omega(\xi)$ for $\xi < \delta$.

We show inductively for $\xi \leq \delta$ that $r \restriction \xi$ is stronger than $p_i^\omega \restriction \xi$ and $p_j^\omega \restriction \xi$ (and that $r \restriction \xi$ is well defined). For ξ limit ordinal or $\xi \notin \text{supp}(p_i^\omega) \cap \text{supp}(p_j^\omega)$ this is immediate.

For $\xi \in \text{supp}(p_i^\omega) \cap \text{supp}(p_j^\omega)$ there is some $\gamma < \kappa^+$ such that $\xi = \xi_\gamma$. Remember $\beta_i < j$ hence $\gamma \leq \alpha_i = \alpha_j < i$. Thus $a_{\xi_\gamma}(i) = a_{\xi_\gamma}(j)$ and by definition of E we also have $i, j \in E_{\xi_\alpha}$. So by construction for each $n < \omega$ we have $r \restriction \xi \Vdash "p_i^n(\xi) \not\leq p_j^n(\xi)"$. Thus by 2.2.7 also $r \restriction \xi \Vdash "p_i^\omega(\xi) \not\leq p_j^\omega(\xi)"$ and let $r(\xi)$ witness it. \square

Fact 2.2.9. Let κ be a cardinal. Let \mathbb{Q} be a κ -linked forcing notion. Then \mathbb{Q} satisfies the stationary κ^+ -Knaster condition. \square

2.3 κ -centered $_{<\kappa}$, preservation in $<\kappa$ -support iterations

Definition 2.3.1. Let κ be a cardinal, let \mathbb{P} be a forcing notion and let $X \subseteq \mathbb{P}$.

1. We say that X is linked if for every $p_0, p_1 \in X$ we have $p_0 \not\leq p_1$.

We say that \mathbb{P} is κ -linked if there exist $\langle X_i : i < \kappa \rangle$ such that $X_i \subseteq \mathbb{P}$ is linked and

$$\mathbb{P} = \bigcup_{i < \kappa} X_i.$$

2. We say that X is centered $_{<\kappa}$ if for every $Y \in [X]^{<\kappa}$ there exists q such that $q \leq p$ for every $p \in Y$.

We say that \mathbb{P} is κ -centered $_{<\kappa}$ if there exist $\langle X_i : i < \kappa \rangle$ such that each $X_i \subseteq \mathbb{P}$ is centered $_{<\kappa}$ and

$$\mathbb{P} = \bigcup_{i < \kappa} X_i.$$

Fact 2.3.2. Let κ be a cardinal and let \mathbb{P} be a forcing notion. Consider the following statements:

- (a) \mathbb{P} is κ -centered $_{<\kappa}$.
- (b) \mathbb{P} is κ -linked.
- (c) \mathbb{P} satisfies the κ^+ -c.c.

Then: (a) \Rightarrow (b) \Rightarrow (c). □

Definition 2.3.3. Let κ be a cardinal. We say that an iteration $\langle \mathbb{P}_\alpha, \dot{\mathbb{Q}}_\alpha : \alpha < \zeta \rangle$ is κ -centered if it has $<\kappa$ -support and

$$\mathbb{P}_\alpha \Vdash \dot{\mathbb{Q}}_\alpha \text{ is } \kappa\text{-centered}_{<\kappa}.$$

Fact 2.3.4. Let $\langle \mathbb{P}_\alpha, \dot{\mathbb{Q}}_\alpha : \alpha < \zeta \rangle$ be a κ -centered iteration. Then there exists a sequences $\langle \dot{C}_\alpha : \alpha < \zeta \rangle$, $\langle \dot{c}_\alpha : \alpha < \zeta \rangle$ such that for all \dot{C}_α and \dot{c}_α are \mathbb{P}_α -names such that \mathbb{P}_α forces:

- (a) \dot{C}_α is a function $\kappa \rightarrow \mathfrak{P}(\dot{\mathbb{Q}}_\alpha)$
- (b) $\text{ran}(\dot{C}_\alpha) = \dot{\mathbb{Q}}_\alpha$
- (c) $i < \kappa \Rightarrow \dot{C}_\alpha(i)$ is centered $_{<\kappa}$
- (d) \dot{c}_α is a function $\dot{\mathbb{Q}}_\alpha \rightarrow \kappa$
- (e) $\dot{q} \in \dot{\mathbb{Q}}_\alpha \Rightarrow \dot{q} \in \dot{C}_\alpha(\dot{c}_\alpha(\dot{q}))$

Without loss of generality we may also assume that each $\dot{C}_\alpha(n)$ is nonempty and closed under weakening of conditions, in particular $1_{\dot{\mathbb{Q}}_\alpha} \in \dot{C}_\alpha(n)$ for each n .

We shall use this notation throughout this section.

Definition 2.3.5. Let $\mathbb{P} = \langle \mathbb{P}_\alpha, \dot{\mathbb{Q}}_\alpha : \alpha < \zeta \rangle$ be a κ -centered iteration. We call a condition $p \in \mathbb{P}$ *fine* if for each $\alpha \in \text{supp}(p)$ the restriction $p \upharpoonright \alpha$ decides some $n < \kappa$ such that $p \upharpoonright \alpha \Vdash "p(\alpha) \in \dot{C}_\alpha(n)"$. Note that for $\alpha \notin \text{supp}(p)$ this is trivially true because $1_{\dot{\mathbb{Q}}_\alpha}$ is in every $\dot{C}_\alpha(n)$.

Definition 2.3.6. Let $\mathbb{P} = \langle \mathbb{P}_\alpha, \dot{\mathbb{Q}}_\alpha : \alpha < \zeta \rangle$ be a κ -centered iteration. We say that \mathbb{P} is *finely $<\kappa$ -closed* if for every $\alpha < \zeta$ with $\text{cf}(\alpha) < \kappa$ there exist $L_\alpha^1 \in \mathbf{V}$ and a \mathbb{P}_α -name \dot{L}_α^2 such that:

- (a) L_α^1 is a function $\kappa^{<\kappa} \rightarrow \kappa$

- (b) $\mathbb{P}_\alpha \Vdash \dot{L}_\alpha^2$ is a function $\dot{Q}_\alpha^{<\kappa} \rightarrow \dot{Q}_\alpha$."
- (c) If $\vec{q} = \langle \dot{q}_i : i < i^* \rangle$ is a descending sequence of length $i^* < \kappa$ in \dot{Q}_α then \mathbb{P}_α forces:
 - (1) $\dot{L}_\alpha^2(\vec{q})$ is a lower bound for \vec{q} .
 - (2) $\dot{c}_\alpha(\dot{L}_\alpha^2(\vec{q})) = L_\alpha^1(\langle \dot{c}_\alpha(\dot{q}_i) : i < i^* \rangle)$.

The typical situation here is that the coloring of the forcing is essentially some trunk function so if we find a lower bound q for some descending sequence $\langle \dot{q}_i : i < \alpha \rangle$ the union of the trunks of the p_i will tell us the color of q .

Lemma 2.3.7. *Let $\mathbb{P} = \langle \mathbb{P}_\alpha, \dot{Q}_\alpha : \alpha < \zeta \rangle$ be a κ -centered finely $<\kappa$ -closed iteration of length $\zeta < (2^\kappa)^+$ then:*

- (a) $\mathbb{P}' = \{p \in \mathbb{P} : p \text{ is fine}\}$ is dense in \mathbb{P} .
- (b) \mathbb{P} is κ -centered $_{<\kappa}$.

Discussion 2.3.8. The following proof closely follows (Blass 2011) where the result is explained for the ω -case. The only adjustment we have to make is the demand for fine closure (as defined in 2.3.6) to deal with the limit case that does not appear in the ω -version of the proof.

This theorem also appears in (Brendle, Brooke-Taylor, Friedman, and Montoya 2018).

Proof.

- (a) Let $p \in \mathbb{P}$ be arbitrary. We are going to find a condition p' stronger than p such that p' is fine. We prove this by induction on $\delta \leq \zeta$ for \mathbb{P}_δ , constructing a decreasing sequence of conditions $\langle p_i : i \leq \delta \rangle$ with $p_i \in \mathbb{P}_\delta$ such that for each $i \leq \delta$ the condition $p_i \upharpoonright (i+1)$ is fine:
 - (i) $p_0 = p$
 - (ii) $i = j + 1$: First find q stronger than $p_i \upharpoonright i$ such that q decides the color of $p_j(i)$. Then use the induction hypothesis to find $q' \leq q$ such that q' is fine and let $p_i = q' \wedge p$.

(iii) i a limit ordinal, $\text{cf}(i) < \kappa$: Consider the condition

$$q' = (\dot{L}_j^2(\langle q_k(j) : k < i \rangle) : j < i) \in \mathbb{P}_i$$

and let $p_i = q' \wedge p$.

(iv) i a limit ordinal, $\text{cf}(i) \geq \kappa$: Remember that \mathbb{P} has $<\kappa$ -support so this case is trivial.

(b) By the Engelking-Karłowicz theorem (Engelking and Karłowicz 1965) there exists a family of functions $\langle f_i : \zeta \rightarrow \kappa \mid i < \kappa \rangle$ such that for any $A \in [\zeta]^{<\kappa}$ and every $f : A \rightarrow \kappa$ there exists $i < \kappa$ such that $f \subseteq f_i$.

For each $k < \kappa$ let

$$D(i) = \{p \in \mathbb{P}_\zeta : \forall \alpha < \kappa : p \upharpoonright \alpha \Vdash p(\alpha) \in \dot{C}_\alpha(f_i(\alpha))\}.$$

It is easy to see that each $D(k)$ is centered $_{<\kappa}$ and that every fine $p \in \mathbb{P}$ is contained in some $D(i)$. So by (a) we are done. \square

Lemma 2.3.9. *Let κ be an inaccessible cardinal with $\sup(\kappa \cap S_\kappa^{\text{inc}}) = \kappa$. Let \mathbb{P} be a forcing notion that does not add new subsets of δ for $\delta < \kappa$ (e.g. \mathbb{P} is κ -strategically closed). Then \mathbb{P} does not add a \mathbb{Q}_κ -generic real if either:*

(a) \mathbb{P} is κ -centered $_{<\kappa}$ or just

(b) \mathbb{P} is $(2^\kappa, \kappa)$ -centered $_{<\kappa}$ meaning that any set $Y \subseteq \mathbb{P}$ of cardinality at most 2^κ is included in the union of at most κ -many centered $_{<\kappa}$ subsets of \mathbb{P} or just

(c) if $p_\rho \in \mathbb{P}, \rho \in 2^\kappa$ is a family of conditions, then for some non-meager $A \subseteq 2^\kappa$ we have

$$u \in [A]^{<\kappa} \Rightarrow \{p_\rho : \rho \in u\} \text{ has a lower bound.}$$

Proof. Clearly (a) \Rightarrow (b) \Rightarrow (c). The first implication is trivial. The second implication follows from the κ^+ -completeness of the meager ideal. So we shall assume (c).

Let $p^* \Vdash \text{“}\dot{\nu} \text{ is a counterexample and thus } \dot{\nu} \upharpoonright \epsilon \in \mathbf{V} \text{ for all } \epsilon < \kappa\text{”}$. (Recall that \mathbb{Q}_κ is strategically κ -closed.) Let $\langle \lambda_\epsilon : \epsilon < \kappa \rangle$ be an increasing enumeration of $\{\lambda \in S_{\text{inc}}^\kappa : \lambda > \sup(\lambda \cap S_{\text{inc}}^\kappa)\}$. Now for $\eta \in 2^\kappa$ let

$$A_\eta = \{\rho \in 2^\kappa : (\forall^\infty \epsilon < \kappa) (\exists^\infty \alpha < \lambda_\epsilon) \eta(\alpha) \neq \rho(\alpha)\}.$$

Clearly $2^\kappa \setminus A_\eta \in \text{id}^-(\mathbb{Q}_\kappa) \subseteq \text{id}(\mathbb{Q}_\kappa)$ as defined in 3.2.1 but we may argue $2^\kappa \setminus A_\eta \in \text{id}(\mathbb{Q}_\kappa)$ as follows: For $\eta \in 2^\kappa$ and $\epsilon < \kappa$ let $B_{\eta,\epsilon} = \{\rho \in 2^{\lambda_\epsilon} : \rho =^* \eta\}$ and note that $|B_{\eta,\epsilon}| = \lambda_\epsilon$, hence $B_{\eta,\epsilon} \in \text{id}(\mathbb{Q}_{\lambda_\epsilon})$. Let $S = \{\lambda_\epsilon : \epsilon < \kappa\}$ and clearly S is nowhere stationary. So for every $\eta \in 2^\kappa$ the set

$$\mathcal{J}_\eta = \{p \in \mathbb{Q}_\kappa : S \subseteq S_p \wedge (\forall \epsilon < \kappa) [\lambda_\epsilon > \text{lg}(\text{tr}(p)) \Rightarrow B_{\eta,\epsilon} \in \text{set}_0(\Lambda_{p,\lambda_\epsilon})]\}$$

is dense in \mathbb{Q}_κ and $p \in \mathcal{J}_\eta \Rightarrow p \Vdash \nu \in A_\eta$.

Now because $2^\kappa \setminus A_\zeta \in \text{id}(\mathbb{Q}_\kappa)$ we have $p^* \Vdash \dot{\nu} \in A_\zeta$ hence for $\eta \in 2^\kappa$ there are (p_η, ζ_η) such that $p_\eta \leq p^*$, $\zeta_\eta < \kappa$, and

$$p_\eta \Vdash_{\mathbb{P}} \text{“if } \epsilon \in [\zeta_\eta, \kappa) \text{ then } (\exists^\infty \alpha < \lambda_\epsilon) \eta(\alpha) \neq \dot{\nu}(\alpha)\text{”}.$$

Hence there exists a non-meager set $Y \subseteq 2^\kappa$ such that any set $\{p_\rho : \rho \in Y\}$ of cardinality $< \kappa$ has a lower bound. Because the meager ideal is κ^+ -complete there exists $\zeta^* < \kappa$ such that without loss of generality $\eta \in Y \Rightarrow \zeta_\eta = \zeta^*$. As Y is non-meager it is somewhere dense. So there exists $\varrho^* \in 2^{<\kappa}$ such that

$$(\forall \varrho \in 2^{<\kappa}) \varrho^* \triangleleft \varrho \in 2^{<\kappa} \Rightarrow (\exists \rho \in Y) \varrho \triangleleft \rho.$$

Without loss of generality $\text{lg}(\varrho^*) = \zeta^*$ (we may increase either value to match the greater one). Choose $\epsilon < \kappa$ such $\lambda_\epsilon > \zeta^*$. Let $\Gamma = \{\varrho \in 2^{\lambda_\epsilon} : \varrho^* \triangleleft \varrho\}$ and for each $\varrho \in \Gamma$ let $\eta_\varrho \in Y$ be such that $\varrho \triangleleft \eta_\varrho$. Now $\{\eta_\varrho : \varrho \in \Gamma\} \in [Y]^{<\kappa}$ hence by the choice of Y there exists a lower bound q of $\{p_{\eta_\varrho} : \varrho \in \Gamma\}$.

As $p^* \Vdash \nu \upharpoonright \epsilon \in V$ without loss of generality let q force a value to $\dot{\nu} \upharpoonright \epsilon$, so call this value ν . Now q is stronger than $p_{\eta_{\varrho^* \upharpoonright [\epsilon, \lambda_\epsilon]}}$ and forces $\lambda_\epsilon = \sup\{\alpha < \lambda_\epsilon : \varrho^* \upharpoonright \nu \upharpoonright [\epsilon, \lambda_\epsilon](\alpha) \neq \dot{\nu}(\alpha)\}$, which means $\lambda_\epsilon = \sup\{\alpha < \kappa : \nu(\alpha) \neq \dot{\nu}(\alpha)\}$. Contradiction to the choice of ν . \square

Remark 2.3.10. Lemma 2.3.9 implies that \mathbb{Q}_κ is not κ -centered $_{<\kappa}$. However, \mathbb{Q}_κ has, for every $\lambda < \kappa$, a dense subset which is κ -centered $_{<\lambda}$, namely the set of conditions with trunk of length $> \lambda$. This parallels the classical case of random forcing, which is not σ -centered, but σ - n -linked for all $n \in \omega$.

Discussion 2.3.11. The following theorem 2.3.12 is a straightforward generalization of (Bartoszyński and Judah 1995, 6.5.30). We formulate it in terms of the ideal $\text{id}^-(\mathbb{Q}_\kappa) \subseteq \text{id}(\mathbb{Q}_\kappa)$. For the definition see 3.2.1.

Lemma 2.3.12. *Let κ be weakly compact. Let \mathbb{P} be a forcing notion such that*

(a) \mathbb{P} is κ -centered $_{<\kappa}$.

(b) \mathbb{P} does not add new subsets of δ for $\delta < \kappa$ (e.g. \mathbb{P} is κ -strategically closed).

Let $(\mathbf{N}, \in) \prec (H(\chi), \in)$ for some χ large enough with $\mathbf{N}^\kappa \subseteq \mathbf{N}$ and $\mathbb{P} \in \mathbf{N}$. Then for $A \in \text{id}^-(\mathbb{Q}_\kappa)$ we have

$$\mathbf{N} \cap 2^\kappa \subseteq A \quad \Rightarrow \quad \mathbb{P} \Vdash \text{“}\mathbf{N}[G] \cap 2^\kappa \subseteq A\text{”}$$

where G is the generic filter of \mathbb{P} . (As usual, A is to be read as a definition of a null set, to be interpreted in \mathbf{V} and $\mathbf{V}^{\mathbb{P}}$.)

Proof. Let $A \in \text{id}^-(\mathbb{Q}_\kappa)$ be witnessed by $\vec{A} = \langle A_\delta : \delta \in S \rangle$, i.e. $A = \text{set}_0^-(\vec{A})$, and let $\mathbb{P} = \bigcup_{\alpha < \kappa} \mathbb{P}_\alpha$ and each \mathbb{P}_α is centered $_{<\kappa}$.

Assume there exists \mathbb{P} name of a κ real $\dot{\eta} \in \mathbf{N}$ and $p^* \in \mathbb{P}$ such that

$$p^* \Vdash \text{“}\dot{\eta} \notin A\text{”}$$

and without loss of generality even

$$p^* \Vdash \text{“}(\forall \delta \geq \delta_0) \dot{\eta} \upharpoonright \delta \notin A_\delta\text{”} \tag{2.1}$$

for some $\delta_0 < \kappa$. For $\alpha < \kappa, \delta \in S$ we define

$$T_{\alpha, \delta} = \{ \nu \in 2^\delta : (\forall p \in \mathbb{P}_\alpha) (\exists q \in \mathbb{P}) q \leq p \text{ and } q \Vdash \text{“}\dot{\eta} \upharpoonright \delta = \nu\text{”} \}.$$

Note that in general we will have $p^* \notin \mathbf{N}$. However, we will have $p^* \in \mathbb{P}_\alpha$ for some α , and the partition $(P_\alpha : \alpha < \kappa)$ is in \mathbf{N} , as is the family $(T_{\alpha, \delta} : \alpha < \kappa, \delta \in S)$.

None of the sets $T_{\alpha, \delta}$ (for all $\alpha < \kappa, \delta \in S$) is empty. We prove this indirectly: Assume $T_{\alpha, \delta} = \emptyset$. Then for every $\nu \in 2^\delta$ there exists $p_\nu \in \mathbb{P}_\alpha$ such that $p_\nu \Vdash \nu \neq \dot{\eta} \upharpoonright \delta$. Now because \mathbb{P}_α is centered $_{<\kappa}$ there exists a lower bound q for $\{p_\nu : \nu \in 2^\delta\}$. Thus for all $\nu \in 2^\delta$ we have $q \Vdash \nu \neq \dot{\eta} \upharpoonright \delta$, contradicting our assumption that \mathbb{P} does not add short sequences.

For $\alpha < \kappa$ consider the tree that is the downward closure of $\bigcup_{\delta \in S} T_{\alpha, \delta}$. Because κ is weakly compact, κ has the tree property thus there exists a branch $\eta_\alpha \in 2^\kappa$ through this tree, i.e. for every $\delta \in S$ we have $\eta_\alpha \upharpoonright \delta \in T_{\alpha, \delta}$. Note that f_α can be calculated from $\dot{\eta}$ hence $f_\alpha \in \mathbf{N}$ so by our assumption $\eta_\alpha \in A$, i.e. $(\exists^\infty \delta \in S) \eta_\alpha \in A_\delta$. Find $\alpha^* < \kappa$ such that $p^* \in \mathbb{P}_{\alpha^*}$ and find $\delta^* \geq \delta_0$ such that $\eta_{\alpha^*} \upharpoonright \delta^* \in A_{\delta^*}$.

Let $\nu = \eta_{\alpha^*} \upharpoonright \delta^* \in T_{\alpha^*, \delta^*}$ so there exists $q \leq p^*$ such that

$$q \Vdash \dot{\eta} \upharpoonright \delta^* = \nu = \eta_{\alpha^*} \upharpoonright \delta^* \in A_{\delta^*}^*.$$

Contradiction to (2.1). □

Corollary 2.3.13. *Let κ be weakly compact. Let \mathbb{P} be a forcing notion such that*

- (a) \mathbb{P} is κ -centered $_{<\kappa}$.
- (b) \mathbb{P} does not add new subsets of δ for $\delta < \kappa$ (e.g. \mathbb{P} is κ -strategically closed).

Then:

- (1) \mathbb{P} does not decrease $\text{non}(\mathbb{Q}_\kappa)$, i.e. if $\text{non}(\mathbb{Q}_\kappa) = \lambda$ then $\mathbb{P} \Vdash \text{“non}(\mathbb{Q}_\kappa) \geq \lambda\text{”}$.
- (2) \mathbb{P} does not increase $\text{cov}(\mathbb{Q}_\kappa)$, i.e. if $\text{cov}(\mathbb{Q}_\kappa) = \lambda$ then $\mathbb{P} \Vdash \text{“cov}(\mathbb{Q}_\kappa) \leq \lambda\text{”}$.

Proof.

1. Let $\mu < \lambda$ and assume $\mathbb{P} \Vdash \text{“}X = \{\dot{\eta}_i : i < \mu\}$ is a set of size $\mu\text{”}$. Find \mathbf{N} as in 2.3.12 with $\dot{\eta}_i \in \mathbf{N}$ for each $i < \mu$ and $|\mathbf{N}| = \mu$. Now because κ is weakly compact by 3.2.5 we have $\mu < \text{non}(\text{id}^-(\mathbb{Q}_\kappa))$ so find $A \in \text{id}^-(\mathbb{Q}_\kappa)$ such that $\mathbf{N} \cap 2^\kappa \subseteq A$. By 2.3.12 we have $\mathbb{P} \Vdash \text{“}X \subseteq \mathbf{N}[G] \subseteq A\text{”}$. I.e.: For any set $X \in \mathbf{V}^{\mathbb{P}}$ of size $\mu < \lambda$ we have $X \in \text{id}^-(\mathbb{Q}_\kappa)$.
 2. We show: \mathbb{P} does not add a \mathbb{Q}_κ -generic real. Assume $\mathbb{P} \Vdash \text{“}\dot{\eta}$ is \mathbb{Q}_κ -generic”.
- Find \mathbf{N} as in 2.3.12 with $\dot{\eta} \in \mathbf{N}$ and $|\mathbf{N}| = \kappa$. Find $A \in \text{id}^-(\mathbb{Q}_\kappa)$ be such that $\mathbf{N} \cap 2^\kappa \subseteq A$. Now by 2.3.12 we have $\mathbb{P} \Vdash \text{“}\dot{\eta} \in \mathbf{N}[G] \subseteq A \in \text{id}^-(\mathbb{Q}_\kappa) \subseteq \text{id}(\mathbb{Q}_\kappa)\text{”}$, a contradiction to $\dot{\eta}$ being \mathbb{Q}_κ generic. □

Remark 2.3.14. So 2.3.13(2) duplicates 2.3.9 but there we do not require κ weakly compact.

2.4 The Fusion Game, preservation in κ -support iterations

The work in this subsection can be considered a generalization of (Kanamori 1980, Section 6), where it is shown how to iterate κ -Sacks forcing for inaccessible κ . The games defined in this subsection and the iteration theorem 2.4.8 first appeared in

(Rosłanowski and Shelah 2006) where \mathfrak{F}_κ^* , \mathfrak{F}_κ (defined below) are called $\mathfrak{D}_\mu^{\text{rcA}}$ and $\mathfrak{D}_\mu^{\text{rca}}$ respectively. However \mathfrak{F}_κ^* , \mathfrak{F}_κ are slightly more general in the sense that White may freely decide the length μ_ζ of the ζ -th round during the game (i.e. our games do not require an additional parameter $\vec{\mu}$).

Definition 2.4.1. Let \mathbb{Q} be a forcing notion and let $q \in \mathbb{Q}$. We define two (very similar) games $\mathfrak{F}_\kappa(\mathbb{Q}, q)$, $\mathfrak{F}_\kappa^*(\mathbb{Q}, q)$ between two players White and Black. A play in either of the games consists of κ -many rounds and for each $\zeta < \kappa$ the ζ -th round lasts μ_ζ -many moves. The rules of the ζ -th round of the game $\mathfrak{F}_\kappa(\mathbb{Q}, q)$ are:

1. First White plays $0 < \mu_\zeta < \kappa$. So White decides the length of the new round.
2. On move $i < \mu_\zeta$:
 - (a) White plays $q_{\zeta,i} \leq q$.
 - (b) Black responds with $q'_{\zeta,i} \leq q_{\zeta,i}$

The rules of the ζ -th round of the game $\mathfrak{F}_\kappa^*(\mathbb{Q}, q)$ are:

1. First White plays $0 < \mu_\zeta < \kappa$. For ζ a limit ordinal we additionally require $\mu_\zeta \leq \sup_{\epsilon < \zeta} \mu_\epsilon$.
2. On move $i < \mu_\zeta$:
 - (a) White plays $q_{\zeta,i} \leq q$ but without looking at any $q'_{\zeta,j}$ for $j < i$. (Equivalently: White plays all moves of the current round at once at the start of the round.)
 - (b) Black responds with $q'_{\zeta,i} \leq q_{\zeta,i}$

The winning condition of both games is the same:

$$\text{White wins} \iff (\exists q^* \leq q) q^* \Vdash “(\forall \zeta < \kappa) \{q'_{\zeta,i} : i < \mu_\zeta\} \cap \dot{G}_\mathbb{Q} \neq \emptyset”.$$

where $\dot{G}_\mathbb{Q}$ is a name for the generic filter of \mathbb{Q} .

Discussion 2.4.2. In point (1.) of the definition of $\mathfrak{F}_\kappa^*(\mathbb{Q}, q)$ we could be slightly more general: Instead of sup any function $f : \kappa^{<\kappa} \rightarrow \kappa$ that gives us an upper bound for μ_ζ based on upper bounds for the μ_ϵ will do. (This is simply a technical requirement for the proof of 2.4.8.) So we could define $\mathfrak{F}_{\kappa,f}^*(\mathbb{Q}, q)$ and let $\mathfrak{F}_\kappa^*(\mathbb{Q}, q) = \mathfrak{F}_{\kappa,\text{id}}^*(\mathbb{Q}, q)$.

Discussion 2.4.3. The typical forcing for which White has a winning strategy for the games defined in 2.4.1 is a tree forcing permitting fusion sequences. See 6.9.6 for an example.

Fact 2.4.4. The game \mathfrak{F}_κ^* is slightly harder for White than the game \mathfrak{F}_κ hence: If White has a winning strategy for $\mathfrak{F}_\kappa^*(\mathbb{Q}, q)$ then White has a winning strategy for $\mathfrak{F}_\kappa(\mathbb{Q}, q)$.

Definition 2.4.5. For technical reasons we define the game $\mathfrak{F}_\kappa^*(\mathbb{Q}, q, \lambda)$ for $\lambda < \kappa$. The rules are the same as for $\mathfrak{F}_\kappa^*(\mathbb{Q}, q)$ except the first λ rounds are skipped and the game starts with the λ -th round. So this is really just an index shift. Of course $\mathfrak{F}_\kappa^*(\mathbb{Q}, q) = \mathfrak{F}_\kappa^*(\mathbb{Q}, q, 0)$ and easily for every $\lambda < \kappa$ White has a winning strategy for $\mathfrak{F}_\kappa^*(\mathbb{Q}, q)$ iff he has a winning strategy for $\mathfrak{F}_\kappa^*(\mathbb{Q}, q, \lambda)$.

Fact 2.4.6. Assume White has a winning strategy for $\mathfrak{G} \in \{\mathfrak{F}_\kappa(\mathbb{Q}, q), \mathfrak{F}_{\kappa^*}(\mathbb{Q}, q)\}$. Then without loss of generality during a run of \mathfrak{G} White only plays moves $q_{\zeta, i}$ such that there exists $\theta_{\zeta, i} \in \prod_{\epsilon < \zeta} \mu_\epsilon$ with

1. $\epsilon < \delta < \zeta \Rightarrow q'_{\epsilon, \theta_{\zeta, i}(\epsilon)} \leq q_{\delta, \theta(\delta)}$.
2. $\epsilon < \zeta \Rightarrow q'_{\epsilon, \theta_{\zeta, i}(\epsilon)} \leq q_{\zeta, i}$.

Consider the tree

$$T = \bigcup_{\zeta < \kappa} \bigcup_{i < \mu_\zeta} \theta_{\zeta, i}.$$

Then a condition q^* witnesses a win for White iff $q^* \Vdash$ “for every $\zeta < \kappa$ there exists a branch $\dot{\theta}$ of T of length ζ such that for every $\epsilon < \zeta$ we have $q'_{\epsilon, \dot{\theta}(\epsilon)} \in \dot{G}_\mathbb{Q}$ ”.

Theorem 2.4.7. *Let \mathbb{Q} be a forcing notion. If for every $q \in \mathbb{Q}$ Black does not have a winning strategy for the game $\mathfrak{F}_\kappa(\mathbb{Q}, q)$ then:*

- (a) *If \dot{A} is a \mathbb{Q} -name such that $q \Vdash |\dot{A}| \leq \kappa$ then there exists $B \in \mathbf{V}$, $|B| \leq \kappa$ and $q^* \leq q$ such that $q^* \Vdash \dot{A} \subseteq B$.*

In particular \mathbb{Q} does not collapse κ^+ .

- (b) *\mathbb{Q} does not increase $\text{cf}(\text{Cohen}_\kappa)$, and in fact: if $\langle A_i : i < \mu \rangle$ are a cofinal family of meager sets in \mathbf{V} then this family remains cofinal in $\mathbf{V}^\mathbb{Q}$.*

- (c) *\mathbb{Q} is κ^κ -bounding.*

Proof.

- (a) Like (b), just easier. But let us do it for warmup.

Let $\langle \dot{a}_\zeta : \zeta < \kappa \rangle$ be such that $q \Vdash \{a_\zeta : \zeta < \kappa\} = \dot{A}$. Now consider a run of $\mathfrak{F}_\kappa(\mathbb{Q}, q)$ where Black's strategy is to play in such way that for each $\zeta < \kappa, i < \mu_\zeta$ there is $b_{\zeta,i}$ such that $q'_{\zeta,i} \Vdash \dot{a}_\zeta = b_{\zeta,i}$. I.e., every move Black makes during the ζ -th round decides \dot{a}_ζ .

By our assumption White can beat this strategy thus there exists $q^* \leq q$ such that $q^* \Vdash \dot{A} \subseteq \{b_{\zeta,i} : \zeta < \kappa, i < \mu_\zeta < \kappa\}$.

- (b) Let us show: if \dot{M} is a \mathbb{Q} -name and $q \Vdash \dot{M}$ is nowhere dense" then there exists a nowhere dense set $N \in \mathbf{V}$ and $q^* \leq q$ such that $q^* \Vdash \dot{M} \subseteq N$. Since meager sets are the union of κ -many nowhere dense sets, we can then use (a) to conclude the proof.

We are going to find $q^* \leq q$ such that for each $s \in 2^{<\kappa}$ there exists $t_s \supseteq s$ such that $q^* \Vdash \dot{M} \cap [t] = \emptyset$ " so

$$N = 2^\kappa \setminus \bigcup_{s \in 2^{<\kappa}} [t_s]$$

is as desired.

Let $\langle s_\zeta : \zeta < \kappa \rangle$ be an enumeration of $2^{<\kappa}$. We will define a strategy for player Black. In addition to his moves $(q'_{\zeta,i}$, he will construct elements $t_{\zeta,i} \in 2^{<\kappa}$ satisfying the following properties:

- (a) $s_\zeta \leq t_{\zeta,j}$.
- (b) $(\bigcup_{j < i} t_{\zeta,j}) \leq t_{\zeta,i}$.
- (c) $q'_{\zeta,i} \Vdash \dot{M} \cap [t_{\zeta,i}] = \emptyset$. (and of course $q'_{\zeta,i} \leq q_{\zeta,i}$, as required by the rules of the game).

Why can Black play like that?

- (a) Obvious.
- (b) Obvious for i successor. For i a limit ordinal just remember $i < \mu_\zeta < \kappa$.
- (c) Remember $q'_{\zeta,i} \leq q \Vdash \dot{M}$ is nowhere dense".

Let $t_\zeta = \bigcup_{i < \mu_\zeta} t_{\zeta,i}$. Again White can beat this strategy so there exists $q^* \leq q$ as required.

(c) Like (b). □

Theorem 2.4.8. *Let $\mathbb{P} = \langle \mathbb{P}_\alpha, \dot{\mathbb{Q}}_\alpha : \alpha < \alpha^* \rangle$ be a κ -support iteration and let $p \in \mathbb{P}$ such that for all $\alpha < \alpha^*$:*

(a) $p \restriction \alpha \Vdash \text{“}\dot{\mathbb{Q}}_\alpha \text{ is } \kappa\text{-strategically closed”}$.

(b) $p \restriction \alpha \Vdash \text{“White has a winning strategy for } \mathfrak{F}_\kappa^*(\dot{\mathbb{Q}}_\alpha, q) \text{ for every } q \leq p(\alpha)\text{”}$.

Then:

(1) *White has a winning strategy for $\mathfrak{F}_\kappa(\mathbb{P}, p)$.*

(2) *If White plays according to his strategy from (1) in a run $\langle p_{\zeta,i}, p'_{\zeta,i} : \zeta < \kappa, i < \mu_\zeta \rangle$ of $\mathfrak{F}_\kappa(\mathbb{P}, p)$ then there exists p^* witnessing White's win such that for all $\alpha < \alpha^*$ we have $p^* \restriction \alpha \Vdash \text{“}\langle p_{\zeta,i}(\alpha), p'_{\zeta,i}(\alpha) : \zeta < \kappa, i < \mu_\zeta \rangle \text{ is a run of } \mathfrak{F}_\kappa^*(\dot{\mathbb{Q}}_\alpha, p(\alpha)) \text{ won by White and White's win is witnessed by } p^*(\alpha)\text{”}$.*

Discussion 2.4.9. Note that the proof of 2.4.8 also works for $\kappa = \omega$.

Proof. Let $p \in \mathbb{P}$ and we are going to show how White can win $\mathfrak{F}_\kappa(\mathbb{P}, p)$ by finding $p^* \leq p$ witnessing White's victory while also being as required by (2). We are going to construct a sequence $\langle p_\zeta : \zeta \leq \kappa \rangle$ such that

1. $\zeta < \kappa \Rightarrow p_\zeta \in \mathbb{P}$.
2. $p_0 = p$.
3. $\epsilon < \zeta \Rightarrow p_\epsilon \geq p_\zeta$.

of which p^* is going to be a lower bound (but remember that under our assumptions the lower bound of a κ -sequence does not exist in general so we will have to construct p^*). We are also going to construct a sequence $\langle F_\zeta : \zeta < \kappa \rangle$ such that

1. $F_0 = \emptyset$
2. $\zeta < \kappa \Rightarrow F_\zeta \subseteq \text{supp}(p_\zeta)$.
3. $\zeta < \kappa \Rightarrow |F_\zeta| < \kappa$.

4. $\epsilon < \zeta \Rightarrow F_\epsilon \subseteq F_\zeta$.

and we are going to use bookkeeping to ensure $F = \bigcup_{\zeta < \kappa} F_\zeta = \bigcup_{\zeta < \kappa} \text{supp}(p_\zeta)$ which is also going to be the support of p^* .

Furthermore we are implicitly going to construct strategies for Black in the games $\mathfrak{F}_\kappa^*(\dot{\mathbb{Q}}_\alpha, p(\alpha))$ for $\alpha \in F$. Then we will choose $p^* = \langle \dot{q}_\alpha^* : \alpha \in F \rangle$ where \dot{q}_α^* witnesses that White can beat Black's strategy.

What does White play in the ζ -th round?

Let $\langle \alpha_{\zeta, \xi} : \xi < \xi_\zeta^* \rangle$ enumerate F_ζ . For $\xi < \xi_\zeta^*$ we want to play the ζ -th round of the game $\mathfrak{F}_\kappa^*(\dot{\mathbb{Q}}_{\alpha_{\zeta, \xi}}, p(\alpha_{\zeta, \xi}))$ where White plays according to the name of a winning strategy (White sticks to same strategy throughout the proof of course). To make notation easier we do not want to keep track of when $\alpha_{\zeta, \xi}$ first appeared F_ϵ for some $\epsilon \leq \zeta$. Instead let $\epsilon_{\zeta, \xi} = \min\{\epsilon \leq \zeta : \alpha_{\zeta, \xi} \in F_\epsilon\}$ and assume we are playing $\mathfrak{F}_\kappa^*(\dot{\mathbb{Q}}_{\alpha_{\zeta, \xi}}, p_{\epsilon_{\zeta, \xi}}(\alpha_{\zeta, \xi}), \epsilon_{\zeta, \xi})$. I.e., we are playing in the ζ -th round for each $\alpha_{\zeta, \xi}$. See 2.4.5.

By induction (we are going to address this further down) we assume for each $\xi < \xi_\zeta^*$ that $p_\zeta \upharpoonright \alpha_{\zeta, \xi} \Vdash \dot{\mu}_{\alpha_{\zeta, \xi}, \zeta} \leq \mu_{\alpha_{\zeta, \xi}, \zeta}$ for some $\mu_{\alpha_{\zeta, \xi}, \zeta} < \kappa$ where $\dot{\mu}_{\alpha_{\zeta, \xi}, \zeta}$ is the length of ζ -th round of $\mathfrak{F}_\kappa^*(\dot{\mathbb{Q}}_{\alpha_{\zeta, \xi}}, p_{\epsilon_{\zeta, \xi}}(\alpha_{\zeta, \xi}), \epsilon_{\zeta, \xi})$ as decided by the name of White's winning strategy. Then there exist (in \mathbf{V} where we are trying to construct a winning strategy) not necessarily injective enumerations $\langle \dot{q}_{\alpha_{\zeta, \xi}, \zeta, i} : i < \mu_{\alpha_{\zeta, \xi}, \zeta} \rangle$ of the moves that White plays according to the name of his winning strategy in the ζ -th round of $\mathfrak{F}_\kappa^*(\dot{\mathbb{Q}}_{\alpha_{\zeta, \xi}}, p_{\epsilon_{\zeta, \xi}}(\alpha_{\zeta, \xi}), \epsilon_{\zeta, \xi})$. To make notation easier we only do the proof for the special case where White always plays an antichain (but the proof works even if White doesn't).

Let $\mu_\zeta = |\prod_{\xi < \xi_\zeta^*} \mu_{\alpha_{\zeta, \xi}, \zeta}|$ and this is what White decides to be the length of the ζ -th round of $\mathfrak{F}_\kappa(\mathbb{P}, p)$. Remember that κ is inaccessible so indeed $\mu_\zeta < \kappa$. Let $\langle \lambda_{\zeta, i} : i < \mu_\zeta \rangle$ enumerate $\prod_{\xi < \xi_\zeta^*} \mu_{\alpha_{\zeta, \xi}, \zeta}$. Now we construct a sequence $\langle p_{\zeta, i} : i < \mu_\zeta \rangle$ (of course anything that is not explicitly stated to be done by Black is part of White's strategy that we are currently constructing):

1. First we find $p_{\zeta, 0} \leq p_\epsilon$ for every $\epsilon < \zeta$ as follows:

- If there is no $\xi < \xi_\zeta^*$ such that $\alpha = \alpha_{\zeta, \xi}$ then let $p_{\zeta, 0}(\alpha)$ be such that $p_{\zeta, 0} \upharpoonright \alpha \Vdash p_{\zeta, 0}(\alpha) \leq p_\epsilon(\alpha)$ according to a winning strategy for White in $\mathfrak{C}(\mathbb{Q}_\alpha)$.

- If there is $\xi < \xi_\zeta^*$ such that $\alpha = \alpha_{\zeta,\xi}$ then let $p_{\zeta,0}(\alpha)$ be such that $p_{\zeta,0} \upharpoonright \alpha \Vdash "p_{\zeta_0}(\alpha) = \bigvee_{\gamma < \mu_{\alpha,\zeta}} \dot{q}_{\alpha,\zeta,\gamma}"$.

Remember 2.4.6 so without loss of generality this implies

$$p_{\zeta,0} \upharpoonright \alpha \Vdash "p_{\zeta_0}(\alpha) \leq p_\epsilon(\alpha)".$$

2. For the i -th move of the ζ -th round White plays $p'_{\zeta,i}$ where

$$p'_{\zeta,i}(\alpha) = \begin{cases} p_{\zeta,i}(\alpha_{\zeta,\xi}) \wedge \dot{q}_{\alpha_{\zeta,\xi},\zeta,\lambda_i(\xi)} & \text{if } \alpha = \alpha_{\zeta,\xi} \text{ for some } \xi < \xi_\zeta^* \\ p_{\zeta,i}(\alpha) & \text{otherwise.} \end{cases}$$

3. Black responds with $p''_{\zeta,i} \leq p'_{\zeta,i}$.

4. Let $p'''_{\zeta,i}$ be such that for $\alpha < \alpha^*$ we have

$$p'''_{\zeta,i} \upharpoonright \alpha \Vdash "p'''_{\zeta,i}(\alpha) \leq p''_{\zeta,i}(\alpha) \text{ and } p'''_{\zeta,i}(\alpha) \text{ is according to a winning strategy for White in } \mathfrak{C}(\dot{\mathbb{Q}}_\alpha)".$$

5. Let $p''''_{\zeta,i}$ be defined by

$$p''''_{\zeta,i}(\alpha) = \begin{cases} (p_{\zeta,i}(\alpha_{\zeta,\xi}) \setminus \dot{q}_{\alpha_{\zeta,\xi},\zeta,\lambda_i(\xi)}) \vee p'''_{\zeta,i}(\alpha_{\zeta,\xi}) & \text{if } \alpha = \alpha_{\zeta,\xi} \text{ for some } \xi < \xi_\zeta^* \\ p'''_{\zeta,i}(\alpha) & \text{otherwise.} \end{cases}$$

and easily check $p''''_{\zeta,i} \leq p$.

6. If $i = j + 1$ then let $p_{\zeta,i} = p'''_{\zeta,j}$. If i is a limit ordinal, then we find $p_{\zeta,i} \leq p_{\zeta,j}$ for every $j < i$ as follows:

- If there is no $\xi < \xi_\zeta^*$ such that $\alpha = \alpha_{\zeta,\xi}$ then let $p_{\zeta,i}(\alpha)$ be such that $p_{\zeta,i} \upharpoonright \alpha \Vdash "p_{\zeta,i}(\alpha) \text{ is according to a winning strategy for White in } \mathfrak{C}(\dot{\mathbb{Q}}_\alpha) \text{ for the sequence } \langle p_{\zeta,j}(\alpha) : j < i \rangle"$.
- If there is $\xi < \xi_\zeta^*$ such that $\alpha = \alpha_{\zeta,\xi}$ then let $p_{\zeta,i}(\alpha)$ be such that

$$p_{\zeta,i} \upharpoonright \alpha \Vdash "p_{\zeta,i}(\alpha) = \bigvee_{\gamma < \mu_{\alpha,\zeta}} \dot{r}_{\zeta,i,\alpha,\gamma}"$$

where $p_{\zeta,i} \upharpoonright \alpha \Vdash "\dot{r}_{\zeta,i,\alpha,\gamma} \text{ is according to a winning strategy for White in } \mathfrak{C}(\dot{\mathbb{Q}}_\alpha) \text{ for the sequence } \langle p_{\zeta,j}(\alpha) \wedge \dot{q}_{\alpha,\zeta,\gamma} : j < i \rangle"$.

Finally let p_ζ be a lowerbound for $\langle p_{\zeta,i} : i < \mu_\zeta \rangle$ as in 6. (but not really, we have to do some preparation work for the next step first, see below). Now the strategy for Black in $\mathfrak{F}_\kappa^*(\dot{\mathbb{Q}}_{\alpha_\zeta, \xi}, p(\alpha_\zeta, \xi))$ is to play $p_\zeta(\alpha_\zeta, \xi) \wedge \dot{q}_{\alpha_\zeta, \xi, \zeta, i}$.

Preparation for the $\zeta + 1$ -th round.

We still have to address why the $\mu_{\alpha_\zeta, \xi, \zeta}$ exist but having understood the proof to this point this is now easy. Let $F_{\zeta+1} = F_\zeta \cup \{\alpha\}$ for some $\alpha \in \text{supp}(p_\zeta) \setminus F_\zeta$, if such α exists (and remember to use bookkeeping). Now for every $\alpha \in F_{\zeta+1}$ work as above on $p_\zeta \upharpoonright \alpha$ and $F_\zeta \cap \alpha$ but instead of taking a response from Black in (3.) White responds to himself deciding $\mu_{\alpha, \zeta+1}$.

So we have prepared for $\zeta + 1$. But what about limit steps? Remember that the rules of \mathfrak{F}_κ^* state that $\dot{\mu}_{\alpha, \zeta} \leq \sup_{\epsilon < \zeta} \dot{\mu}_{\alpha, \epsilon}$. So if we let $F_\zeta = \bigcup_{\epsilon < \zeta} F_\epsilon$ all is good because having an estimate for successor steps gives us an estimate for limit steps.

Why does White win?

Because for $\alpha \in F = \bigcup_{\zeta < \kappa} F_\zeta$ there exists a \mathbb{Q}_α -name \dot{q}_α^* such that $p \upharpoonright \alpha \Vdash \text{“}\dot{q}_\alpha^* \text{ witnesses that White wins if Black plays as described above in } \mathfrak{F}_\kappa^*(\dot{\mathbb{Q}}_\alpha, p(\alpha))\text{”}$.

By construction $p^* = \langle \dot{q}_\alpha^* : \alpha \in F \rangle$ is as required. \square

2.5 Fusion and Properness

In this subsection we give a sufficient condition for a limit of a $\leq \kappa$ -support iteration to be κ -proper, namely, the existence of winning strategies for the games $\mathfrak{F}_\kappa^*(\dot{\mathbb{Q}}_\alpha)$ for all iterands \mathbb{Q}_α encountered in the iteration.

We also show that if all iterands have cardinality $\leq \kappa^+$, and the length δ of the iteration is $< \kappa^{++}$, then the resulting forcing \mathbb{P}_δ has a dense set of size κ^+ and in particular will still satisfy the κ^{++} -c.c.

Definition 2.5.1. In this section we consider an iteration $\mathbb{P} = \langle \mathbb{P}_\alpha, \mathbb{Q}_\alpha : \alpha < \delta \rangle$ with limit \mathbb{P}_δ such that:

1. $\delta < \kappa^{++}$
2. \mathbb{P} has κ -support.
3. White has a winning strategy for $\mathfrak{F}_\kappa^*(\dot{\mathbb{Q}}_\alpha, \dot{q})$ for every $\alpha < \delta$ and $\dot{q} \in \dot{\mathbb{Q}}_\alpha$.
4. In $\mathbf{V}^{\mathbb{P}_\alpha}$ the forcing \mathbb{Q}_α has size at most κ^+ .

For $\alpha < \delta$ let \dot{b}_α be a \mathbb{P}_α -name of a one-to-one map from κ^+ onto \dot{Q}_α .

Lemma 2.5.2. *Let (\mathbf{N}, \in) a model of size κ , closed under $<\kappa$ -sequences, let \mathbb{R} be an arbitrary forcing notion such that $\mathbb{R} \in \mathbf{N}$ and $(\mathbf{N}, \in) \prec (H(\chi), \in)$ for some χ large enough. If White has a winning strategy for $\mathfrak{F}_\kappa(\mathbb{R}, p)$ then for every $p \in \mathbb{R} \cap \mathbf{N}$ there exists $q^* \in \mathbb{R}$, $q^* \leq p$ such that q^* is \mathbf{N} - \mathbb{R} -generic. This means:*

1. For every maximal antichain A of \mathbb{R} with $A \in \mathbf{N}$ we have

$$q^* \Vdash A \cap \mathbf{N} \cap \dot{G}_\mathbb{R} \neq \emptyset.$$

2. Or equivalently: for every name $\dot{\tau}$ of an ordinal with $\dot{\tau} \in \mathbf{N}$ we have

$$q^* \Vdash \dot{\tau} \in \mathbf{N}.$$

Proof. Note that because $|\mathbf{N}| = \kappa$ there are at most κ -many names of ordinals in \mathbf{N} . By our assumption White has a winning strategy for $\mathfrak{F}_\kappa(\mathbb{R}, p)$ and because \mathbf{N} is an elementary submodel White has a winning strategy that lies in \mathbf{N} . Now consider a run of the game where:

1. White plays according to his winning strategy in \mathbf{N} . By induction all these moves are in \mathbf{N} by our assumption $\mathbf{N}^{<\kappa} \subseteq \mathbf{N}$.
2. Black decides all ordinals of \mathbf{N} such that they lie in \mathbf{N} by playing $p'_{\zeta, i} \in \mathbf{N}$ for $\zeta < \kappa, i < \mu_\zeta$.

Now q^* witnessing White's win is \mathbf{N} -generic. □

Definition 2.5.3. Let \mathbb{R} be a forcing notion. Consider a run of the game $\mathfrak{G} \in \{\mathfrak{F}_\kappa, \mathfrak{F}_\kappa^*\}$ where:

1. White wins.
2. Black plays $\vec{p}' = \langle p'_{\zeta, i} : \zeta < \kappa, i < \mu_\zeta \rangle$.

Then we call q^* witnessing White's win a \mathfrak{G} -fusion limit of \vec{p}' .

Corollary 2.5.4. *Let \mathbb{P} be as in 2.5.1. Then:*

- (a) For every $p \in \mathbb{P} \cap \mathbf{N}$ there exists a generic condition $q^* \leq p$ that is a $\mathfrak{F}_\kappa(\mathbb{P})$ -fusion limit of \vec{p}' with $p'_{\zeta, i} \in \mathbf{N}$ for all $\zeta < \kappa, i < \mu_\zeta$. (However, in general we will have $q^* \notin \mathbf{N}$.)

(b) Furthermore for $\alpha < \delta$ we have $q^* \upharpoonright \alpha \Vdash "q^*(\alpha) \text{ is a } \mathfrak{F}_\kappa^*(\dot{\mathbb{Q}}_\alpha)\text{-fusion limit}"$.

Proof.

- (a) By 2.5.1(3) and 2.4.8(1) White has a winning strategy for $\mathfrak{F}_\kappa(\mathbb{R}, p)$ so use 2.5.1.
- (b) By 2.4.8(2).

□

Definition 2.5.5. For $\alpha < \kappa$ a condition $p \in \mathbb{P}_\alpha$ is called a H_κ -condition if for every $\beta < \alpha$ the \mathbb{P}_β -name $p(\beta)$ is a H_κ - \mathbb{P}_β -name.

For $\alpha < \delta$ we inductively define the notion of a H_κ - \mathbb{P}_α -name. On the one hand we consider H_κ -names for elements of κ^+ , on the other hand for elements of $\dot{\mathbb{Q}}_\alpha$.

1. $\dot{\tau}$ is a H_κ -name for an element of κ^+ iff $\dot{b}_\alpha(\dot{\tau})$ is a H_κ -name of an element of $\dot{\mathbb{Q}}_\alpha$. (b_α was defined in 2.5.1.)
2. For every $\gamma \in \kappa^+$, the standard name $\check{\gamma}$ is a H_κ -name.
3. For every sequence $\langle (p_i, \dot{\tau}_i) : i < \kappa \rangle$ where p_i are H_κ - \mathbb{P}_α -conditions and $\dot{\tau}_i$ are H_κ - \mathbb{P}_α -names there exists a H_κ -name $\dot{\tau}$ forced to be equal to $\dot{\tau}_i$ where i is the least index such that $p_i \in \dot{G}_\mathbb{P}$ if such i exists, $\check{0}$ otherwise.
4. For every $\mathfrak{F}_\kappa^*(\dot{\mathbb{Q}}_\alpha)$ -fusion sequence \vec{p}' where $p'_{\zeta,i}$ are H_κ - \mathbb{P}_α -names for elements of $\dot{\mathbb{Q}}_\alpha$ there exists a H_κ -name $\dot{\tau}$ that is forced to be equal to the condition witnessing White's win. (If it exists; $\check{0}$ otherwise.)

Remark 2.5.6. The “ H_κ ”-names are an easy generalization of the “hereditarily countable” names appearing in (Shelah 1998, 4.1), see also (Goldstern and Kellner 2016).

Lemma 2.5.7. For every condition $p \in \mathbb{P}$ there exists a H_κ -condition $q^* \leq p$.

Proof. First let \mathbf{N} be a model of size κ with $p, \mathbb{P} \in \mathbf{N}$ and let q^* be a $\mathfrak{F}_\kappa(\mathbb{P})$ -fusion limit with $p'_{\zeta,i} \in \mathbf{N}$ as in 2.5.4.

Now we will try to find a H_κ -name for $p'_{\zeta,i}(\alpha)$, for all $\zeta, \alpha < \kappa, i < \mu_\zeta$.

For $\alpha \in \text{supp}(q^*)$ we define $p''_{\zeta,i}(\alpha)$ as follows. We find (in \mathbf{N}) a maximal antichain $A = A_{\zeta,i,\alpha}$ that decides $\dot{b}_\alpha^{-1}(p'_{\zeta,i}(\alpha))$, i.e. there exists a function $f = f_{\zeta,i,\alpha}: A \rightarrow \kappa^+$, such that for all $r \in A$

$$r \Vdash p'_{\zeta,i}(\alpha) = \dot{b}_\alpha(f(r)).$$

Let $A' = A \cap \mathbf{N}$. Consider the sequence $\langle (r, b_\alpha(f(r))) : r \in A' \rangle$. This family defines a H_κ -name $p''_{\zeta,i}(\alpha)$.

Now because $q^* \upharpoonright \alpha$ is \mathbf{N} -generic

$$q^* \upharpoonright \alpha \Vdash p'_{\zeta,i}(\alpha) = p''_{\zeta,i}(\alpha)$$

Hence $q^* \upharpoonright \alpha$ forces that $q^*(\alpha)$ is equal to a witness of White's win against $p''_{\zeta,i}(\alpha)$, i.e. $q^*(\alpha)$ is a $\mathfrak{F}_\kappa^*(\mathbb{Q}_\alpha)$ -fusion limit. Hence $q^*(\alpha)$ is a H_κ -name so q^* is a H_κ -condition. \square

Corollary 2.5.8. *Let \mathbb{P}_δ be as in 2.5.1 (so in particular $\delta < \kappa^{++}$). Then there exists $D \subseteq \mathbb{P}_\delta$ such that*

1. D is dense.
2. $|D| = \kappa^+$.
3. \mathbb{P}_δ has the κ^{++} -c.c.

Proof. Follows immediately from 2.5.7. \square

Corollary 2.5.9. *Assume $2^\kappa = \kappa^+$, and let $\mathbb{P} = (\mathbb{P}_\alpha, \mathbb{Q}_\alpha : \alpha < \kappa^{++})$ be an iteration with limit $\mathbb{P}_{\kappa^{++}}$ satisfying the following:*

1. \mathbb{P} has κ -support.
2. For each $\alpha < \kappa^{++}$ we have $\mathbb{P}_\alpha \Vdash |\mathbb{Q}_\alpha| = 2^\kappa$.
3. For each $\alpha < \kappa^{++}$ and each name $\dot{q} \in \dot{\mathbb{Q}}_\alpha$, \mathbb{P}_α forces that White has a winning strategy for the fusion game $\mathfrak{F}_\kappa^*(\dot{\mathbb{Q}}_\alpha, \dot{q})$. (Defined in 2.4.1, see 2.4.3 for which forcings this may be the case.)

Then we have:

- (a) For each $\alpha < \kappa^{++}$ the forcing notion \mathbb{P}_α has a dense subset of cardinality κ^+ .
- (b) For each $\alpha < \kappa^{++}$, \mathbb{P}_α forces $2^\kappa = \kappa^{++}$.
- (c) For each $\delta \leq \kappa^{++}$, \mathbb{P}_δ has the κ^{++} -c.c.

Proof. The κ^{++} -c.c. of $\mathbb{P}_{\kappa^{++}}$ follows by the Solovay-Tennenbaum theorem from the fact that \mathbb{P} uses direct limits on a stationary set, namely, the set of ordinals of cofinality κ^+ . (See (Solovay and Tennenbaum 1971).)

The rest just summarizes previous theorems. \square

CHAPTER 3

Smaller Ideals

In this section we first describe two ideals $\text{wid}(\mathbb{Q}_\kappa)$ and $\text{id}^-(\mathbb{Q}_\kappa)$, both of which are closely related (and often equal) to $\text{id}(\mathbb{Q}_\kappa)$. We then give a more “combinatorial” characterization of $\text{add}(\mathbb{Q}_\kappa)$ and $\text{cof}(\mathbb{Q}_\kappa)$, involving the additivity and cofinality of the ideal $\mathbf{nst}_\kappa^{\text{Pr}}$ of nowhere stationary subsets of $S_{\text{Pr}}^\kappa \subseteq \kappa$.

3.1 The ideal $\text{wid}(\mathbb{Q}_\kappa)$

Definition 3.1.1. For $\text{id}(\mathbb{Q}_\kappa)$ we allow κ many antichains to define $A \in \text{id}(\mathbb{Q}_\kappa)$. But we may also consider the weak ideal $\text{wid}(\mathbb{Q}_\kappa)$ of all sets $A \subseteq 2^\kappa$ such that for some maximal antichain \mathcal{A} (or equivalently: every predense set \mathcal{A}) we have $A \subseteq \text{set}_0(\mathcal{A})$, where $\text{set}_0(\mathcal{A}) := 2^\kappa \setminus \bigcup_{p \in \mathcal{A}} [p]$.

Lemma 3.1.2.

- (a) $\text{wid}(\mathbb{Q}_\kappa) \subseteq \text{id}(\mathbb{Q}_\kappa)$.
- (b) $\text{wid}(\mathbb{Q}_\kappa) = \text{id}(\mathbb{Q}_\kappa)$ iff $\neg \text{Pr}(\kappa)$.
- (c) $\text{wid}(\mathbb{Q}_\kappa)$ is κ -complete.

Proof.

- (a) Trivial: If \mathcal{A} witnesses $A \in \text{wid}(\mathbb{Q}_\kappa)$ then $\Lambda = \{\mathcal{A}\}$ witnesses $A \in \text{id}(\mathbb{Q}_\kappa)$.

- (b) Assume $\neg \text{Pr}(\kappa)$. Let Λ be a set of at most κ -many maximal antichains of \mathbb{Q}_κ and without loss of generality assume that Λ is closed under rational shifts, i.e. for all $\eta_1, \eta_2 \in 2^\kappa$ we have

$$\eta_1 =^* \eta_2 \quad \Rightarrow \quad [\eta_1 \in \text{set}_0(\Lambda) \Leftrightarrow \eta_2 \in \text{set}_0(\Lambda)].$$

Let $A \subseteq \text{set}_0(\Lambda)$. By our assumption about κ there exists $p \in \mathbb{Q}_\kappa$ such that $[p] \subseteq \text{set}_1(\Lambda)$ and let p be witnessed by $(\tau, S, \vec{\Gamma})$. Let

$$\mathcal{A} = \{q \in \mathbb{Q}_\kappa : q \text{ is witnessed by } (\rho, S, \vec{\Gamma}) \text{ for some } \rho \in 2^{<\kappa}\}$$

and check that \mathcal{A} is predense. Now easily $q \in \mathcal{A} \Rightarrow [q] \subseteq \text{set}_0(\Lambda)$ hence $\text{set}_1(\mathcal{A}) \subseteq \text{set}_1(\Lambda)$ hence $A \subseteq \text{set}_0(\mathcal{A})$, i.e. $A \in \text{wid}(\mathbb{Q}_\kappa)$.

Conversely assume $\text{wid}(\mathbb{Q}_\kappa) = \text{id}(\mathbb{Q}_\kappa)$ and let Λ be a set of no more than κ -many maximal antichains of \mathbb{Q}_κ . By our assumption there exists a maximal antichain \mathcal{A} of \mathbb{Q}_κ such that

$$\bigcup_{p \in \mathcal{A}} [p] = \text{set}_1(\mathcal{A}) \subseteq \text{set}_1(\Lambda).$$

Hence for any $p \in \mathcal{A}$ we have $[p] \subseteq \text{set}_1(\Lambda)$; as Λ was arbitrary, we get $\neg \text{Pr}(\kappa)$.

- (c) Because \mathbb{Q}_κ is strategically κ -closed. □

Lemma 3.1.3. *Consider the usual forcing ideal*

$$\text{fid}(\mathbb{Q}_\kappa) = \{A \subseteq 2^\kappa : (\forall p \in \mathbb{Q}_\kappa)(\exists q \leq p) [q] \cap A = \emptyset\}.$$

Then we have $\text{fid}(\mathbb{Q}_\kappa) = \text{wid}(\mathbb{Q}_\kappa)$.

Proof. Let $A \in \text{wid}(\mathbb{Q}_\kappa)$ be witnessed by \mathcal{A} . Now for any $p \in \mathbb{Q}_\kappa$ there exists $p' \in \mathcal{A}$ such that p and p' are compatible. Let $q = p \cap p'$ and clearly $A \cap [q] = \emptyset$, hence $A \in \text{fid}(\mathbb{Q}_\kappa)$

Conversely if $A \in \text{fid}(\mathbb{Q}_\kappa)$ then the set $\mathcal{D} = \{q : [q] \cap A = \emptyset\}$ is dense. Choose any maximal antichain $\mathcal{A} \subseteq \mathcal{D}$, then \mathcal{A} will witness $A \in \text{wid}(\mathbb{Q}_\kappa)$. □

3.2 The ideal $\text{id}^-(\mathbb{Q}_\kappa)$

Definition 3.2.1. The ideal $\text{id}^-(\mathbb{Q}_\kappa)$ consists of all sets $A \subseteq 2^\kappa$ for which there exists a nowhere stationary set $S \subseteq S_{\text{inc}}^\kappa$ and a sequence $\vec{\Lambda} = \langle \Lambda_\delta : \delta \in S \rangle$ such that

each Λ_δ is a set of at most δ -many maximal antichains of \mathbb{Q}_δ such that

$$A \subseteq \text{set}_0(\vec{\Lambda}) = \{\eta \in 2^\kappa : (\exists^\infty \delta \in S) \eta \upharpoonright \delta \in \text{set}_0(\Lambda_\delta)\}.$$

For a nowhere stationary set $S \subseteq S_{\text{inc}}^\kappa$ we define $\text{id}^-(\mathbb{Q}_{\kappa,S})$ to be the ideal of all sets A such that:

1. $A \in \text{id}^-(\mathbb{Q}_\kappa)$.
2. A is witnessed by a sequence $\langle A_\delta : \delta \in W \rangle$ such that $W \subseteq S$.

Note that we are often lazy and use the notation $\text{add}(\mathbb{Q}_\kappa)$. This always means $\text{add}(\text{id}(\mathbb{Q}_\kappa))$, never $\text{add}(\text{id}^-(\mathbb{Q}_\kappa))$. The same applies for cov , non and cf .

Lemma 3.2.2. $\text{id}^-(\mathbb{Q}_\kappa) \subseteq \text{wid}(\mathbb{Q}_\kappa)$.

Proof. Given $S \subseteq S_{\text{inc}}^\kappa$ and $\vec{\Lambda} = \langle \Lambda_\delta : \delta \in S \rangle$ let $p_\rho \in \mathbb{Q}_\kappa$ be the condition witnessed by $(\rho, S, \vec{\Lambda})$ and let $\mathcal{D} = \{p_\rho : \rho \in 2^{<\kappa}\}$. It is easy to check that $\text{set}_0^-(\vec{\Lambda}) \subseteq \text{set}_0(\mathcal{D})$. \square

Theorem 3.2.3. *Let κ be a weakly compact cardinal. Then $\text{id}^-(\mathbb{Q}_\kappa) = \text{wid}(\mathbb{Q}_\kappa)$.*

Lemma 3.2.4. $\text{id}^-(\mathbb{Q}_\kappa)$ is $<\kappa^+$ -complete.

Proof of Lemma 3.2.4. For $i < \kappa$ let $(S_i, \vec{\Lambda}^i)$ represent $A_i = \text{set}_0^-(\vec{\Lambda}_i) \in \text{id}^-(\mathbb{Q}_\kappa)$. Let

$$S^* = \{\delta < \kappa : (\exists i < \delta) \delta \in S_i\}$$

be the diagonal union of S_i and for $\delta \in S^*$ let $\Lambda_\delta^* = \cup\{\Lambda_{i,\delta} : i < \delta\}$ and easily

$$\bigcup_{i < \kappa} A_i \subseteq \text{set}_0^-(\vec{\Lambda}^*).$$

\square

Proof of Theorem 3.2.3. Let $D = \{p_\epsilon : \epsilon < \kappa\} \subseteq \mathbb{Q}_\kappa$ be a maximal antichain witnessing $A \subseteq \text{set}_0(D) \in \text{wid}(\mathbb{Q}_\kappa)$. For $\epsilon < \kappa$ let p_ϵ be witnessed by $(\tau_\epsilon, S_\epsilon, \vec{\Lambda}_\epsilon)$. Using weak compactness we find a sequence $\langle \delta_\alpha : \alpha < \kappa \rangle$ such that

1. $\delta_\alpha \in S_{\text{inc}}^\kappa$.
2. $\delta_\alpha > \sup_{\beta < \alpha} \delta_\beta$.

3. $D_\alpha = \{p_\epsilon \cap 2^{<\delta_\alpha} : \epsilon < \delta_\alpha\}$ is a maximal antichain in $\mathbb{Q}_{\delta_\alpha}$.

Let

$$S_\alpha^* = \left(\bigcup_{\epsilon < \delta_\alpha} S_\epsilon \right) \setminus \delta_\alpha$$

and let

$$S^* = \bigcup_{\alpha < \kappa} S_\alpha^* \cup \{\delta_\alpha : \alpha < \kappa\}.$$

It is easy to check that S^* is nowhere stationary. For $\delta \in S^*$ we define

$$\Lambda_\delta^* = \bigcup_{\epsilon < \delta} \Lambda_{\epsilon, \delta} \cup \begin{cases} \{D_\alpha\} & \text{if } \delta = \delta_\alpha \text{ for some } \alpha < \kappa \\ \emptyset & \text{otherwise.} \end{cases}$$

We claim that $\text{set}_0(D) \subseteq \text{set}_0^-(\bar{\Lambda}^*)$, witnessing $A \in \text{id}^-(\mathbb{Q}_\kappa)$. Let $\eta \in \text{set}_0(D)$.

Case 1: $(\exists^\infty \alpha < \kappa) \eta \upharpoonright \delta_\alpha \in \text{set}_0(D_\alpha)$. Thus clearly $\eta \in \text{set}_0^-(\bar{\Lambda}^*)$.

Case 2: $(\forall^\infty \alpha < \kappa) \eta \upharpoonright \delta_\alpha \in \text{set}_1(D_\alpha)$. So $\eta \upharpoonright \delta_\alpha \in [p_{\epsilon_\alpha} \cap 2^{<\delta_\alpha}]$ for some $\epsilon_\alpha < \delta_\alpha$ for almost all (or just infinitely many) $\alpha < \kappa$. However $\eta \in \text{set}_0(D_\alpha)$ implies that $\eta \notin [p_{\epsilon_\alpha}]$. Hence there exists $\delta \in S_{\epsilon_\alpha} \setminus \delta_\alpha$ such that $\eta \upharpoonright \delta \in \text{set}_0^-(\Lambda_{\epsilon_\alpha, \delta})$. Recall that $\Lambda_{\epsilon_\alpha, \delta} \subseteq \Lambda_\delta^*$ and thus $\eta \in \text{set}_0^-(\bar{\Lambda}^*)$. \square

Corollary 3.2.5. *Let κ be a weakly compact cardinal. Then $\text{id}^-(\mathbb{Q}_\kappa) = \text{id}(\mathbb{Q}_\kappa)$.*

Proof. By (Shelah 2017, Observation 4.4) κ weakly compact implies $\neg \text{Pr}(\kappa)$ which by 3.1.2(b) implies $\text{wid}(\mathbb{Q}_\kappa) = \text{id}(\mathbb{Q}_\kappa)$. So by 3.2.3 the result follows. \square

Lemma 3.2.6. *Let $S \subseteq \kappa$ be nowhere stationary. Then we can find:*

1. *A regressive function f on S .*
2. *A family $\{E_\alpha : \alpha \leq \kappa, \text{cf}(\alpha) > \omega\}$ where $E_\alpha \subseteq \alpha$ is a club disjoint from $S \cap \alpha$.*

such that:

- (a) $(\forall \delta \in \kappa \setminus \omega) |\{\lambda \in S \setminus \delta : f(\lambda) \leq \delta\}| < \delta$.
- (b) $(\forall \alpha)(\forall \lambda \in E_\alpha) \delta > \lambda \Rightarrow f(\delta) > \lambda$.

Proof. We prove by induction on $\beta \leq \kappa$ that we can find a regressive function f_β on $S \cap \beta$ and a family $\{E_\alpha : \alpha < \beta\}$ with the required properties. For $\beta = \kappa$ the result follows.

Case 1: $\beta > \sup(S \cap \beta)$. Obvious.

Case 2: $\beta = \sup(S \cap \beta)$, $\text{cf}(\beta) > \omega$. Let $E_\beta = \langle \alpha_\zeta : \zeta < \text{cf}(\beta) \rangle$ be an increasing continuous cofinal sequence in β , disjoint from S .

Let

$$S_\zeta = S \cap [\alpha_\zeta, \alpha_{\zeta+1})$$

and let f_ζ be a function on S_ζ from the induction hypothesis. Without loss of generality $\lambda \in S_\zeta \Rightarrow f_\zeta(\lambda) \geq \alpha_\zeta$. [Why? Just round up, i.e., replace $f_\zeta(\lambda)$ by $\max(\alpha_\zeta, f_\zeta(\lambda))$]. The new function is still regressive, because $\alpha_\zeta \notin S$.) So

$$f = \bigcup_{\zeta < \text{cf}(\beta)} f_\zeta$$

is as required.

Case 3: $\beta = \sup(S \cap \beta)$, $\text{cf}(\beta) = \omega$. This is similar to Case 2: Fix an increasing sequence $(\alpha_n : n \in \omega)$ cofinal in β . Define $f(\alpha_{n+1}) := \alpha_n$, and use the induction hypothesis to get $f \upharpoonright (\alpha_n, \alpha_{n+1})$. This does not violate (a) because we require $\delta > \omega$ there.

By construction, the sets E_β have the property (b). \square

Theorem 3.2.7. *Let $A \in \text{id}^-(\mathbb{Q}_\kappa)$ be represented by $\vec{\Lambda} = \langle \Lambda_\delta : \delta \in S \rangle$. Then there exists $A' \in \text{id}^-(\mathbb{Q}_\kappa)$ represented by $\vec{\Lambda}' = \langle \Lambda'_\delta : \delta \in S' \rangle$ such that:*

1. $A \subseteq A'$
2. $S' \in \mathbf{nst}_\kappa^{\text{pr}}$
3. $S \cap S_{\text{pr}}^\kappa \subseteq S'$
4. $\delta \in S \cap S' \Rightarrow \Lambda_\delta \subseteq \Lambda'_\delta$.

Proof. First without loss of generality we assume A is closed under rational translates (see 1.3.3) and in particular Λ_δ are closed under rational translates. For $\delta \in S \setminus S_{\text{pr}}^\kappa$ find $p_\delta \in \mathbb{Q}_\delta$ witnessed by $(\langle \cdot \rangle, \vec{\Gamma}_\delta, S_\delta)$ such that $[p_\delta] \subseteq \Lambda_\delta$. By 1.4.5 we may assume $S_\delta \subseteq S_{\text{pr}}^\delta$.

Now let f be a regressive function on S as in 3.2.6 and let

$$S' = (S \cap S_{\text{pr}}^\kappa) \cup \bigcup_{\delta \in S \setminus S_{\text{pr}}^\kappa} S_\delta \setminus (f(\delta) + 1)$$

and for $\delta \in S'$ let

$$\Lambda'_\delta = \cup\{\Gamma_{\delta^*,\delta} : \delta^* > \delta > f(\delta)\} \cup \begin{cases} \Lambda_\delta & \delta \in S \cap S_{\text{pr}}^\kappa \\ \emptyset & \text{otherwise.} \end{cases}$$

Why is S' nowhere stationary? Let $\alpha < \kappa$, $\text{cf}(\alpha) > \omega$. Why is $S' \cap \alpha$ not stationary in α .

- $\alpha > \sup(S \cap \alpha)$. Use 3.2.6(a).
- $\alpha = \sup(S \cap \alpha)$. For the part of $S' \cap \alpha$ that comes from S_δ with $\delta < \alpha$ use 3.2.6(b) to show that the club set E_α is disjoint to $S_\delta \setminus (f(\delta) + 1)$, for all $\delta < \alpha$. For the part that comes from S_δ with $\delta > \alpha$ use (a) as above.

See 3.3.16 for the same argument carried out in more detail. Similarly argue $|\Lambda'_\delta| \leq \delta$ that.

Now check that $S', \vec{\Lambda}'$ define a set $A' \in \text{id}^-$ covering A . □

3.3 Characterizing Additivity and Cofinality

Lemma 3.3.1 (Null set normal form theorem). *Let $\kappa = \sup(S_{\text{inc}} \cap \kappa)$ and let $A \in \text{id}(\mathbb{Q}_\kappa)$. For $\epsilon < \kappa$ let $W_\epsilon \subseteq \kappa = \sup(W_\epsilon)$ and otherwise arbitrary (e.g. disjoint). Then there exist $S, \vec{\Lambda} = \langle \Lambda_\delta : \delta \in S \rangle, \vec{p}, \vec{\mathcal{J}} = \langle \mathcal{J}_\epsilon : \epsilon < \kappa \rangle$ such that*

1. $S \subseteq \kappa$ is nowhere stationary.
2. $S \subseteq S_{\text{pr}}^\kappa$.
3. $\vec{p} = \{p_\rho : \rho \in 2^{<\kappa}\}$ where $p_\rho \in \mathbb{Q}_\kappa$ is witnessed by $(\rho, S, \vec{\Lambda})$.
4. $\mathcal{J}_\epsilon \subseteq \{p_\rho : \rho \in 2^{<\kappa} \wedge \text{lg}(\rho) \in W_\epsilon\}$ is predense in \mathbb{Q}_κ (or even a maximal antichain).
5. $A \subseteq \text{set}_0(\mathcal{J})$.

Discussion 3.3.2. So the idea is as follows: a general null set A is represented by κ -many antichains each consisting of κ -many conditions that are all witnessed by different nowhere stationary sets S and sequences $\vec{\Lambda}$. But using a diagonalization argument we find a representation of the null set using only a single S and $\vec{\Lambda}$.

Lemma 3.3.1 first appears in (Shelah 2017, 3.16) but we repeat a sketch of the proof here for the convenience of the reader.

Proof. Let $A \in \text{id}(\mathbb{Q}_\kappa)$ be witnessed by $\langle \mathcal{I}_\epsilon : \epsilon < \kappa \rangle$ maximal antichains of \mathbb{Q}_κ . Let $\mathcal{I}_\epsilon = \{p_{\epsilon,i} : i < \kappa\}$ and let $p_{\epsilon,i}$ be witnessed by $(\tau_{\epsilon,i}, S_{\epsilon,i}, \vec{\Lambda}_{\epsilon,i})$. By 1.4.5 we may assume without loss of generality $S_{\epsilon,i} \subseteq S_{\text{pr}}^\kappa$.

Let

$$S = \{\delta \in \kappa : (\exists \epsilon, i < \delta) \delta \in S_{\epsilon,i}\}$$

and it is easy to see that S is nowhere stationary. For $\delta \in S$ let

$$\Lambda_\delta = \cup\{\Lambda_{\epsilon,i,\delta} : \epsilon < \delta, i < \delta, \delta \in S_{\epsilon,i}\}$$

and it is easy to see that $|\Lambda_\delta| \leq \delta$. Finally let

$$\mathcal{J}_\epsilon = \{p_\rho : (\exists i, \epsilon < \kappa) i, \epsilon < \text{lg}(\rho) \in W_\epsilon \wedge \eta_{\epsilon,i} \supseteq \rho\}.$$

Now check. □

Corollary 3.3.3 (Baire's theorem for $\text{id}(\mathbb{Q}_\kappa)$). *The ideal $\text{id}(\mathbb{Q}_\kappa)$ is not trivial.*

Proof. If $\kappa > \sup(S_{\text{inc}} \cap \kappa)$ then $\text{id}(\mathbb{Q}_\kappa) = \text{id}(\text{Cohen}_\kappa)$ so the corollary follows from Baire's theorem for the meager ideal on 2^κ .

If $\kappa = \sup(S_{\text{inc}} \cap \kappa)$ let $S, \vec{p}, \langle \mathcal{J}_\epsilon : \epsilon < \kappa \rangle$ be as in 3.3.1. Let $E \subseteq \kappa$ be a club disjoint from S . We construct an sequence $\langle \rho_\epsilon : \epsilon < \kappa \rangle$ of $\rho_\epsilon \in 2^{<\kappa}$ such that:

1. $p_{\rho_\epsilon} \in \mathcal{J}_\epsilon$.
2. $\zeta < \epsilon \Rightarrow \rho_\zeta \trianglelefteq \rho_\epsilon$.
3. (As a consequence:) $\zeta < \epsilon \Rightarrow p_{\rho_\epsilon} \leq p_{\rho_\zeta}$, and in particular $\rho_\epsilon \in p_{\rho_\zeta}$.

We work inductively: If $\epsilon = \zeta + 1$ find $\rho_\epsilon \in \mathcal{J}_\epsilon$ such that:

- (a) $p_{\rho_\epsilon} \not\leq p_{\rho_\zeta}$
- (b) $(\text{lg}(\rho_\epsilon), \text{lg}(\rho_\zeta)) \cap E \neq \emptyset$

If ϵ is a limit then let $\rho'_\epsilon = \bigcup_{\zeta < \epsilon} \rho_\zeta$ and find $\rho_\epsilon \supseteq \rho'_\epsilon$ as above. (Letting $\delta := \text{lg}(\rho'_\epsilon)$ we have $\delta \in E$, so no branches die out in level δ , so $\rho'_\epsilon \in p_{\rho_\zeta}$ for all $\zeta < \epsilon$.)

Finally let $\eta = \bigcup_{\epsilon < \kappa} \rho_\epsilon$ and clearly $\eta \in \text{set}_1(\mathcal{J})$, i.e. $\text{set}_0(\mathcal{J}) \neq 2^\kappa$. □

Lemma 3.3.4. *Let κ be Mahlo (or at least S_{pr}^κ stationary). Then there exist maps*

1. $\phi^+ : \text{id}(\mathbb{Q}_\kappa) \rightarrow \mathbf{nst}_\kappa^{\text{pr}}$

2. $\phi^- : \mathbf{nst}_\kappa^{\text{pr}} \rightarrow \text{id}^-(\mathbb{Q}_\kappa)$

such that for all $S \in \mathbf{nst}_\kappa^{\text{pr}}$, $A \in \text{id}(\mathbb{Q}_\kappa)$:

$$\phi^-(S) \subseteq A \quad \Rightarrow \quad S \subseteq^* \phi^+(A).$$

Discussion 3.3.5. Lemma 3.3.4 first appears implicitly in (Shelah 2017) but proving it in terms of the $\text{id}^-(\mathbb{Q}_\kappa)$ ideal and strengthened Galois-Tukey connections may be more transparent.

Proof. For $\lambda \in S_\kappa^{\text{pr}}$ let Λ_λ^* witness $\lambda \in S_\kappa^{\text{pr}}$. For $S \in \mathbf{nst}_\kappa^{\text{pr}}$ define

$$\phi^-(S) = \{\eta \in 2^{<\kappa} : (\exists^\infty \delta \in S) \eta \upharpoonright \delta \in \text{set}(\Lambda_\delta^*)\}$$

and for $A \in \text{id}(\mathbb{Q}_\kappa)$ define $\phi^+(A) = S$ where S is as in 3.3.1.

Now let $A \in \text{id}(\mathbb{Q}_\kappa)$, $S^* \in \mathbf{nst}_\kappa^{\text{pr}}$ be such that $S^* \not\subseteq^* \phi^+(A)$ and we are going to show $\phi^-(S^*) \not\subseteq A$. So let $(S, \vec{\Lambda}, \vec{p}, \vec{\mathcal{J}})$ be as in 3.3.1 for A (so $\phi^+(A) = S$). By our assumption $S' = S^* \setminus S$ is unbounded. Easily we can find an unbounded set $S'' \subseteq S'$ with its closure E disjoint from S . (Simply take a club C disjoint from S and working inductively for $\epsilon \in C$ take $\lambda \in S'$ such that $\epsilon \leq \lambda$.)

We are going to inductively construct a \triangleleft -increasing sequence $\langle \eta_i : i < \kappa \rangle$ in $\eta_i \in 2^{<\kappa}$ and an increasing sequence $\langle \delta_i : i < \kappa \rangle$ of $\delta_i \in \kappa$ such that for $i < \kappa$:

- (a) $|\eta_i| = \delta_i$
- (b) $\delta_i \in E$ (thus in particular $\delta_i \notin S$)
- (c) $i = j + 1 \Rightarrow \delta_i \in S''$ (thus in particular $\delta_i \in S^*$)
- (d) $[p_{\eta_i}] \subseteq \bigcap_{j < i} \text{set}_1(\mathcal{J}_j)$
- (e) $i = j + 1 \Rightarrow \eta_i \in \text{set}_0(\Lambda_{\delta_i}^*)$

Now let $\eta = \bigcup_{i < \kappa} \eta_i$ and note that

- $\eta \in \phi^-(S^*)$ by clause (e).
- $\eta \notin A$ by clause (d).

It remains to prove that we can indeed carry out this induction. The case $i = 0$ is trivial. For i limit let $\eta_i = \bigcup_{j < i} \eta_j$. (remember (b)).

For $i = j + 1$ consider p_{η_j} . Because \mathcal{J}_j is predense we find $\rho \in 2^{<\kappa}$ such that $p_\rho \in \mathcal{J}_j$ and p_{η_j}, p_ρ are compatible with lower bound p_ν , $\nu = \rho \cup \eta_j$. Choose $\delta_i \in S''$ such that $\delta_i > |\nu|$. Now we have that $[p_\nu \cap 2^{<\delta_i}] \not\subseteq \text{set}_1(\Lambda_{\delta_i}^*)$ so choose $\eta_i \in [p_\nu \cap 2^{<\delta_i}] \setminus \text{set}_1(\Lambda_{\delta_i}^*)$ and note that because $\delta_i \notin S$ we have $\eta_i \in p_{\eta_j}$ hence $p_{\eta_i} \subseteq p_{\eta_j}$. \square

Theorem 3.3.6. *Let κ be Mahlo (or at least S_{pr}^κ stationary). Then:*

1. $\text{add}(\text{id}^-(\mathbb{Q}_\kappa), \text{id}(\mathbb{Q}_\kappa)) \leq \text{add}(\mathbf{nst}_\kappa^{\text{pr}})$.
2. $\text{cf}(\text{id}^-(\mathbb{Q}_\kappa), \text{id}(\mathbb{Q}_\kappa)) \geq \text{cf}(\mathbf{nst}_\kappa^{\text{pr}})$.

Proof. By 3.3.4 and 1.5.8. \square

Corollary 3.3.7. *Let κ be Mahlo (or at least S_{pr}^κ stationary). Then:*

1. $\text{add}(\text{id}(\mathbb{Q}_\kappa)) \leq \text{add}(\mathbf{nst}_\kappa^{\text{pr}})$.
2. $\text{add}(\text{id}^-(\mathbb{Q}_\kappa)) \leq \text{add}(\mathbf{nst}_\kappa^{\text{pr}})$.
3. $\text{cf}(\text{id}(\mathbb{Q}_\kappa)) \geq \text{cf}(\mathbf{nst}_\kappa^{\text{pr}})$.
4. $\text{cf}(\text{id}^-(\mathbb{Q}_\kappa)) \geq \text{cf}(\mathbf{nst}_\kappa^{\text{pr}})$. \square

Definition 3.3.8. We define

$$\mathbb{Q}_{\kappa, S}^* = \{p \in \mathbb{Q}_\kappa : S_p \subseteq S\}.$$

Note that we have $\mathbb{Q}_{\kappa, S} \subseteq \mathbb{Q}_{\kappa, S}^*$ but in general equality does not hold.

Theorem 3.3.9. *Let κ be Mahlo (or let at least S_{pr}^κ be stationary). Then*

$$\text{add}(\text{id}(\mathbb{Q}_\kappa)) = \min\{\mu_1, \mu_2\}$$

where

- $\mu_1 = \text{add}(\mathbf{nst}_\kappa^{\text{pr}})$.
- $\mu_2 = \min\{\text{add}(\text{id}(\mathbb{Q}_{\kappa, S}^*), \text{id}(\mathbb{Q}_\kappa)) : S \in \mathbf{nst}_\kappa^{\text{pr}}\}$.

Proof. Let $\mu = \text{add}(\mathbb{Q}_\kappa)$. $\mu \leq \mu_1$ follows from Theorem 3.3.6 (remember 1.5.4) and $\mu \leq \mu_2$ is trivial. So it remains to show that $\mu \geq \min\{\mu_1, \mu_2\}$.

Let $A_i \in \text{id}(\mathbb{Q}_\kappa)$ for $i < i^* < \min\{\mu_1, \mu_2\}$ and let $(S_i, \vec{\Lambda}_i, \vec{\mathcal{J}}_i, \vec{p}_i)$ be as in 3.3.1. By 1.4.5 we may assume that $S_i \in \mathbf{nst}_\kappa^{\text{pr}}$ and because $i^* < \mu_1$ there is $S \in \mathbf{nst}_\kappa^{\text{pr}}$ such that $i < i^* \Rightarrow S_i \subseteq^* S$. Thus easily $A_i \in \text{id}(\mathbb{Q}_{\kappa, S}^*)$ and because $i^* < \mu_2$ we have $\bigcup_{i < i^*} A_i \in \text{id}(\mathbb{Q}_\kappa)$. □

Theorem 3.3.10. *Let κ be Mahlo (or let at least S_{pr}^κ be stationary). Then*

$$\text{cf}(\text{id}(\mathbb{Q}_\kappa)) = \mu_1 + \mu_2$$

where

- $\mu_1 = \text{cf}(\mathbf{nst}_\kappa^{\text{pr}})$.
- $\mu_2 = \sup\{\text{cf}(\text{id}(\mathbb{Q}_{\kappa, S}^*)), \text{id}(\mathbb{Q}_\kappa) : S \in \mathbf{nst}_\kappa^{\text{pr}}\}$.

Proof. Let $\mu = \text{cf}(\mathbb{Q}_\kappa)$. $\mu \geq \mu_1$ follows from Theorem 3.3.6 (remember 1.5.4) and $\mu \geq \mu_2$ is trivial. So it remains to show that $\mu \leq \mu_1 + \mu_2$.

Let $\langle S_\zeta : \zeta < \mu_1 \rangle$ witness μ_1 and for $\zeta < \mu$ let $\langle A_{\zeta, \epsilon} : \epsilon < \mu_2 \rangle$ witness $\text{cf}(\text{id}(\mathbb{Q}_{\kappa, S_\zeta}^*)), \text{id}(\mathbb{Q}_\kappa) \leq \mu_2$. We claim that

$$\{A_{\zeta, \epsilon} : \zeta < \mu_1, \epsilon < \mu_2\}$$

is a cofinal family of $\text{id}(\mathbb{Q}_\kappa)$. Thus let $A \in \text{id}(\mathbb{Q}_\kappa)$ be arbitrary and let $(S, \vec{\Lambda}, \vec{\mathcal{J}}, \vec{p})$ be as in 3.3.1. By 1.4.5 we may assume that $S \in \mathbf{nst}_\kappa^{\text{pr}}$ and find $\zeta < \mu_1, \alpha^* < \kappa$ such that $S \setminus \alpha^* \subseteq S_\zeta \setminus \alpha^*$. For $\delta \in S_\zeta$ define

$$\Lambda'_\delta = \begin{cases} \Lambda_\delta & \text{if } \delta \in S \setminus \alpha^* \\ \emptyset & \text{if } \delta \notin S \text{ or } \delta < \alpha^* \end{cases}$$

Now for each $i < \kappa$ correct \mathcal{J}_i to \mathcal{J}'_i such that it uses only trunks of length greater than α^* . Thus we have found $A' \subseteq A$ and $A' \in \text{id}(\mathbb{Q}_{\kappa, S_\zeta}^*)$. Hence there exists $\epsilon < \mu_2$ such that $A' \subseteq A_{\zeta, \epsilon}$. □

Definition 3.3.11. Let $S \subseteq \kappa$ and we define

$$\Pi_S = \left(\prod_{\delta \in S} (\text{id}(\mathbb{Q}_\delta) / \text{id}^-(\mathbb{Q}_\delta)), \leq^* \right)$$

where the intended meaning of \leq^* is pointwise set-inclusion for almost all places of the product. Writing $[\Lambda_\delta]$ for the id^- -equivalence class of Λ_δ , for $\vec{\Lambda} = \langle [\Lambda_\delta] : \delta \in S \rangle$, $\vec{\Gamma} = \langle [\Gamma_\delta] : \delta \in S \rangle \in \Pi_S$ we define

$$\vec{\Lambda} \leq^* \vec{\Gamma} \Leftrightarrow (\forall^\infty \delta \in S) \Lambda_\delta \setminus \Gamma_\delta \in \text{id}^-(\mathbb{Q}_\delta).$$

Lemma 3.3.12. *Let $S \in \mathbf{nst}_\kappa$, $\text{sup}(S) = \kappa$. Then there exist maps:*

1. $\phi^+ : \text{id}(\mathbb{Q}_\kappa) \rightarrow \Pi_S$
2. $\phi^- : \Pi_S \rightarrow \text{id}^-(\mathbb{Q}_\kappa)$

such that for all $\vec{\Lambda} \in \Pi_S$, $A \in \text{id}(\mathbb{Q}_\kappa)$:

$$\phi^-(\vec{\Lambda}) \subseteq A \quad \Rightarrow \quad \vec{\Lambda} \leq^* \phi^+(A).$$

Proof. Then for $\vec{\Lambda} = \langle [\Lambda_\delta] : \delta \in S \rangle \in \Pi_S$ define $\phi^-(\vec{\Lambda}) = \text{set}_0^-(\langle \Lambda_\delta : \delta \in S \rangle)$. Given $A \in \text{id}(\mathbb{Q}_\kappa)$, find any Λ as in 3.3.1 and define $\phi^+(A) = \Lambda \upharpoonright S$.

Now assume $A \in \text{id}(\mathbb{Q}_\kappa)$, $\Lambda^* \in \Pi_S$ such that $\Lambda^* \not\leq^* \phi^+(A)$ and we are going to show $\phi^-(\Lambda^*) \not\subseteq A$. Let $\vec{\Lambda}^* = \langle [\Lambda_\delta^*] : \delta \in S \rangle$ and for A there are (as in 3.3.1) $S_A, \vec{\mathcal{J}}$, $\vec{\Lambda} = \langle \Lambda_\delta : \delta \in S_A \rangle = \phi^+(A)$ (without loss of generality ($S_A \supseteq S$)) such that we have

$$(\exists^\infty \delta \in S) \neg(\text{set}_0(\Lambda_\delta) \supseteq \text{set}_0(\Lambda_\delta^*)) \pmod{\text{id}^-(\mathbb{Q}_\delta)}.$$

Let $B_\delta = \text{set}_1(\Lambda_\delta) \cap \text{set}_0(\Lambda_\delta^*)$. Hence by the above we have

$$(\exists^\infty \delta \in S) B_\delta \notin \text{id}^-(\mathbb{Q}_\delta).$$

We are going to show

- (*) there exists $\eta \in (2^\kappa \setminus A) \cap \text{set}_0^-(\vec{\Lambda}^*)$, witnessing $\text{set}_0^-(\vec{\Lambda}^*) \not\subseteq A$.

Without loss of generality assume closure under rational translates, i.e. $\text{set}_0(\Lambda_\delta)^{[\beta]} = \text{set}_0(\Lambda_\delta)$ for $\beta < \delta \in S$, and clearly we may assume the same for $\vec{\Lambda}^*$.

Claim: Let $p_\rho \in \mathbb{Q}_\kappa$ be the condition witnessed by $(\rho, S_A, \vec{\Lambda})$. Then for all $\rho \in 2^{<\kappa}$, there exists $\delta \in S \setminus (\text{lg}(\rho) + 1)$ such that

$$(p_\rho \cap 2^\delta) \cap \text{set}_0(\Lambda_\delta^*) \neq \emptyset.$$

To see this choose $\delta > \text{lg}(\rho)$ such that $B_\delta \in \text{id}^-(\mathbb{Q}_\delta)$ and let

$$C_\delta = \{\eta \in 2^\delta : (\forall^\infty \sigma \in S_A \cap \delta) \eta \upharpoonright \sigma \in \text{set}_1(\Lambda_\sigma)\}.$$

The idea is that C_δ is a set of candidates for elements of $p_\rho \cap 2^\delta$. Towards contradiction assume that

$$C_\delta \subseteq \text{set}_0(\Lambda_\delta) \cup \text{set}_1(\Lambda_\delta^*) = \neg B_\delta$$

i.e. every candidate either dies out at level δ by definition of p_ρ or is not in $\text{set}_0(\Lambda_\delta^*)$. But clearly $C_\delta = \text{set}_1(\vec{\Lambda} \upharpoonright \delta)$ i.e. is a $\text{co-id}^-(\mathbb{Q}_\delta)$ set, contradicting $B_\delta \notin \text{id}^-(\mathbb{Q}_\delta)$. Hence there exists $\eta \in C_\delta \cap B_\delta$. Now use the closure under rational translates and choose $\beta \in (\text{lg}(\text{tr}(p_\rho)), \delta)$ large enough such that for $\nu \in 2^\beta \cap p_\rho$ we have

$$\nu \upharpoonright \beta \frown \eta \upharpoonright (\beta, \delta) \in (p_\rho \cap 2^\delta) \cap \text{set}_0(\Lambda_\delta^*).$$

This concludes to proof of the claim.

Now fix a club E disjoint from S and work as in 3.3.4 constructing a \triangleleft -increasing sequence $\langle \eta_i : i < \kappa \rangle$ of $\eta_i \in 2^{<\kappa}$ and an increasing sequence $\langle \delta_i : i < \kappa \rangle$ of $\delta_i \in \kappa$ such that for $i < \kappa$:

- (a) $|\eta_i| = \delta_i$.
- (b) $i = j + 1 \Rightarrow \delta_i \in S$.
- (c) $i \text{ limes} \Rightarrow \delta_i \in E$.
- (d) $[p_{\eta_i}] \subseteq \bigcap_{j < i} \text{set}_1(\mathcal{J}_j)$.
- (e) $i = j + 1 \Rightarrow \eta_i \in \text{set}_0(\Lambda_{\delta_i}^*)$.

Finally let $\eta = \bigcup_{i < \kappa} \eta_i$ and note that

- $\eta \in \text{set}_0(\Lambda^*) = \phi^-(\vec{\Lambda}^*)$ by clause (e).
- $\eta \notin A$ by clause (d).

So we have shown (*).

It remains to check that we can carry out the induction. For $i = j + 1$ we find $p_\rho \in \mathcal{J}_i$ such that p_ρ and p_{η_j} are compatible. Now let $\nu = \rho \cup \eta_j$ and we find $\delta_i > |\nu|$ such that $\delta_i \in B_\delta$ and $(\delta_j, \delta_i) \cap E \neq \emptyset$. Now using the claim we find $\eta_i \in p_\nu \cap 2^{\delta_i} \cap \text{set}_0(\Lambda_{\delta_i}^*)$. \square

Theorem 3.3.13. *Let $S \in \mathbf{nst}_\kappa$, $\text{sup}(S) = \kappa$. Then:*

1. $\text{add}(\text{id}^-(\mathbb{Q}_\kappa), \text{id}(\mathbb{Q}_\kappa)) \leq \text{add}(\Pi_S)$.

2. $\text{cf}(\text{id}^-(\mathbb{Q}_\kappa), \text{id}(\mathbb{Q}_\kappa)) \geq \text{cf}(\Pi_S)$.

Proof. By 3.3.12 and 1.5.8. □

We will use the following definition and the revised GCH theorem from (Shelah 2000).

Definition 3.3.14. Let μ, θ be cardinals such that $\theta < \mu$ and θ regular. We define

$$\mu^{[\theta]} = \min\{|U| : U \subseteq \mathfrak{P}(\mu) \wedge \varphi(U)\}$$

where $\varphi(U)$ iff:

1. All $u \in U$ have size θ .
2. Every $v \subseteq \mu$ of size θ is contained in the union of fewer than θ members of U .

Theorem 3.3.15 (The revised GCH theorem). *Let α be an uncountable strong limit cardinal, i.e. $\beta < \alpha \Rightarrow 2^\beta < \alpha$. E.g. $\alpha = |\mathbf{V}_{\omega+\omega}| = \beth_\omega$, the first strong limit cardinal. Then for every $\mu \geq \alpha$ for some $\epsilon < \alpha$ we have:*

$$\theta \in [\epsilon, \alpha] \wedge \theta \text{ is regular} \Rightarrow \mu^{[\theta]} = \mu.$$

□

Theorem 3.3.16. *Let κ be Mahlo (or at least S_{pr}^κ stationary). Then:*

- (a) $\text{cf}(\text{id}^-(\mathbb{Q}_\kappa)) = \mu_1 + \mu_2$.
- (b) $\text{cf}(\text{id}(\mathbb{Q}_\kappa)) = \mu_1 + \mu_2 + \mu_3$.

where

- $\mu_1 = \text{cf}(\mathbf{nst}_{\text{pr}}^\kappa)$.
- $\mu_2 = \sup(\text{cf}(\Pi_S) : S \in \mathbf{nst}_{\text{pr}}^\kappa)$
- $\mu_3 = \text{cf}(\text{id}(\mathbb{Q}_\kappa)/\text{id}^-(\mathbb{Q}_\kappa))$.

Proof. The inequality \geq :

- (a) Let $\mu^* = \text{cf}(\text{id}^-(\mathbb{Q}_\kappa), \text{id}(\mathbb{Q}_\kappa))$. Then remembering 1.5.4:

- (1) $\mu^* \geq \mu_1$ by 3.3.6.
- (2) $\mu^* \geq \mu_2$ by 3.3.13.

(b) Use the same theorems. Finally $\text{cf}(\text{id}(\mathbb{Q}_\kappa)) \geq \mu_3$ is trivial.

The inequality \leq : We only show (a) which using 1.5.5 easily implies (b).

1. Let $\langle S_\zeta : \zeta < \mu_1 \rangle$ witness $\mu_1 = \text{cf}(\mathbf{nst}_{\text{pr}}^\kappa)$, i.e.

- (a) $\zeta < \mu_1 \Rightarrow S_\zeta \in \mathbf{nst}_{\text{pr}}^\kappa$.
- (b) $(\forall S \in \mathbf{nst}_{\text{pr}}^\kappa)(\exists \zeta < \mu_1) S \subseteq^* S_\zeta$.

2. For every $\zeta < \mu_1$ let $\langle \vec{A}_{\zeta,i} : i < \mu_2 \rangle$ witness $\mu_{2,S_\zeta} \leq \mu_2$, i.e.

- (a) $\vec{A}_{\zeta,i} = \langle A_{\zeta,i,\delta} : \delta \in S_\zeta \rangle$.
- (b) $A_{\zeta,i,\delta} \in \text{id}(\mathbb{Q}_\delta)$, representing the equivalence class $[A_{\zeta,i,\delta}] \in \text{id}(\mathbb{Q}_\delta) / \text{id}^-(\mathbb{Q}_\delta)$.
- (c) for all $\vec{A} \in \prod_{\delta \in S_\zeta} \text{id}(\mathbb{Q}_\delta)$, there is some $i < \mu_2$ such that for every δ large enough we have $A_\delta \subseteq A_{\zeta,i,\delta} \pmod{\text{id}^-(\mathbb{Q}_\delta)}$.
- (d) Changing the representative of $[A_{\zeta,i,\delta}]$ if necessary we may assume

$$\{\eta \in 2^\delta : (\exists^\infty \sigma \in S_\zeta \cap \delta) \eta \upharpoonright \sigma \in A_{\zeta,i,\sigma}\} \subseteq A_{\zeta,i,\delta}.$$

3. Let

$$\theta = \min\{\theta : \theta = \text{cf}(\theta) < |\mathbf{V}_{\omega+\omega}| \wedge (\mu_1 + \mu_2)^{[\theta]} = \mu_1 + \mu_2\},$$

see 3.3.14 and 3.3.15 for definition of notation and existence of θ .

For $u \in [\mu_1 \times \mu_2]^\theta$

- (a) $S_u = \cup\{S_\zeta : \{\zeta\} \times \mu_2 \cap u \neq \emptyset\}$.
- (b) For $\delta \in S_u$ we inductively define $A_{u,\delta} = \cup\{A_{\zeta,i,\delta} : (\zeta, i) \in u\} \cup \{\eta \in 2^\delta : (\exists^\infty \sigma \in S_u \cap \delta) \eta \upharpoonright \sigma \in A_{u,\sigma}\}$.
- (c) $A_u = \{\eta \in 2^\kappa : (\exists^\infty \delta \in S) \eta \upharpoonright \delta \in A_{u,\delta}\}$.

4. Note that in (3) (because for any $\delta \in S_{\text{inc}}$ we have $\delta > |\mathbf{V}_{\omega+\omega}| > \theta$).

- (a) $S_u \in \mathbf{nst}_{\text{pr}}^\kappa$.

(b) $A_{u,\delta} \in \text{id}(\mathbb{Q}_\delta)$.

(c) $A_u \in \text{id}^-(\mathbb{Q}_\kappa)$.

5. Remembering 3.3.14, 3.3.15 we find \vec{u} such that

(a) $\vec{u} = \langle u_\alpha : \alpha < \mu_1 + \mu_2 \rangle$.

(b) $u_\alpha \in [\mu_1 \times \mu_2]^\theta$.

(c) If $u \in [\mu_1 \times \mu_2]^\theta$ then it is the union of fewer than θ members of $\{u_\alpha : \alpha < \mu_1 + \mu_2\}$.

We claim that $\langle A_{u_\alpha} : \alpha < \mu_1 + \mu_2 \rangle$ is a cofinal family in $\text{id}^-(\mathbb{Q}_\kappa)$. So let $A \in \text{id}^-(\mathbb{Q}_\kappa)$ be arbitrary and for $\epsilon < \theta$ we inductively define $A_\epsilon, \zeta_\epsilon, i_\epsilon$, etc. such that:

(a) $A \subseteq A_0$.

(b) $\epsilon' < \epsilon \Rightarrow A_{\epsilon'} \subseteq A_\epsilon$.

(c) $A_\epsilon = \text{set}_0^-(\vec{\Lambda}_\epsilon^1) \in \text{id}^-(\mathbb{Q}_\kappa)$ where:

(a) $\vec{\Lambda}_\epsilon^1 = \langle \Lambda_{\epsilon,\delta}^1 : \delta \in S_\epsilon^1 \rangle$.

(b) $S_\epsilon^1 \in \mathbf{nst}_{\text{pr}}^\kappa$ (remember 3.2.7)

(c) $\Lambda_{\epsilon,\delta}^1$ is a set of at most δ -many maximal antichains of \mathbb{Q}_δ .

(d) $\zeta_\epsilon < \mu_1$ is minimal such that $S_\epsilon^1 \subseteq^* S_{\zeta_\epsilon}^1$.

(e) $\vec{\Lambda}_\epsilon^2 = \langle \Lambda_{\epsilon,\delta}^2 : \delta \in S_{\zeta_\epsilon}^1 \rangle$ is such that $\delta \in S_\epsilon^1 \cap S_{\zeta_\epsilon}^1 \Rightarrow \Lambda_{\epsilon,\delta}^1 = \Lambda_{\epsilon,\delta}^2$. (E.g. choose $\Lambda_{\epsilon,\delta}^2 = \emptyset$ for $\delta \in S_{\zeta_\epsilon}^1 \setminus S_\epsilon^1$.)

(f) $i_\epsilon < \mu_2$ is minimal such that for some $S_\epsilon^3 \subseteq S_{\zeta_\epsilon}^2, S_\epsilon^3 =^* S_{\zeta_\epsilon}^2$:

$$(\forall \delta \in S_\epsilon^3) (\text{set}_0(\Lambda_{\epsilon,\delta}^2) \subseteq A_{\zeta_\epsilon, i_\epsilon, \delta}) \quad \text{mod } \text{id}^-(\mathbb{Q}_\delta).$$

(g) $\vec{\Lambda}_\epsilon^4 = \langle \Lambda_{\epsilon,\delta}^4 : \delta \in S_\epsilon^3 \rangle$ is such that:

(1) $S_\epsilon^3 \subseteq S_\epsilon^4 \in \mathbf{nst}_{\text{pr}}^\kappa$.

(2) If $\delta \in S_\epsilon^3$ then $A_{\zeta_\epsilon, i_\epsilon, \delta} \subseteq \text{set}_0(\Lambda_{\epsilon,\delta}^4)$.

(3) If $\delta \in S_\epsilon^3$ then $\text{set}_0(\Lambda_{\epsilon,\delta}^2) \subseteq \text{set}_0(\Lambda_{\epsilon,\delta}^4) \cup \text{set}_0^-(\vec{\Lambda}_\epsilon^4 \upharpoonright \delta)$. This point is the only non-explicit step, see below for why we can do this.

(h) If $\epsilon = \epsilon' + 1$ then $S_\epsilon^1 = S_{\epsilon'}^4$, $\vec{\Lambda}_\epsilon^1 = \vec{\Lambda}_{\epsilon'}^4$.

(i) If ϵ is a limit then $S_\epsilon^1 = \bigcup_{\epsilon' < \epsilon} S_{\epsilon'}^1$, $\Lambda_{\epsilon, \delta}^4 = \bigcup_{\epsilon' < \epsilon} \Lambda_{\epsilon', \delta}^4$.

Why is carrying out the induction enough?

Note $\{(\zeta_\epsilon, i_\epsilon) : \epsilon < \theta\} \in [\mu_1 \times \mu_2]^\theta$ so we use (5)(c) to find $\alpha < \mu_1 + \mu_2$ such that

$$(\exists^\infty \epsilon < \theta) (\zeta_\epsilon, i_\epsilon) \in u_\alpha. \quad (3.1)$$

Remember $\theta < |\mathbf{V}_{\omega+\omega}| < \text{cf}(\kappa)$ and find $\psi^* < \kappa$ such that

$$(\forall \epsilon < \theta) S_\epsilon^1 \setminus \psi^* \subseteq S_\epsilon^2 \setminus \psi^* \subseteq S_\epsilon^3 \setminus \psi^* \subseteq S_\epsilon^4 \setminus \psi^* \subseteq S_{\epsilon+1}^1 \setminus \psi^*$$

We plan to show $A \subseteq A_{u_\alpha}$. So let $\eta \in A_0$ be arbitrary; we will show $\eta \in A_{u_\alpha}$.

Let $W \subseteq S_0^1 \setminus \psi^*$, $\text{sup}(W) = \kappa$ be such that

$$(\forall \delta \in W) \eta \upharpoonright \delta \in \text{set}_0(\Lambda_{0, \delta}^1).$$

Now we claim

$$(\forall \delta \in W) (\forall^\infty \epsilon < \theta) \eta \upharpoonright \delta \in A_{\zeta_\epsilon, i_\epsilon, \delta}. \quad (3.2)$$

We prove this by induction on $\delta \in S_\theta^1 \setminus \psi^*$.

- $\delta > \text{sup}(\delta \cap S_{\text{inc}})$. Then $\text{id}^-(\mathbb{Q}_\delta)$ trivial so in (f) we always really (i.e. not just modulo $\text{id}^-(\mathbb{Q}_\delta)$) cover $\text{set}_0(\Lambda_{\epsilon, \delta}^2)$.
- $\delta = \text{sup}(\delta \cap S_{\text{inc}})$ and $\delta = \text{sup}(\delta \cap S_\theta^1)$. By induction hypothesis we have

$$(\forall \sigma \in S_\theta^1 \cap \delta) (\exists \epsilon_\sigma < \theta) (\forall \epsilon \geq \epsilon_\sigma) \eta \upharpoonright \sigma \in A_{\zeta_\epsilon, i_\epsilon, \sigma}$$

δ is inaccessible so in particular regular, hence there exists ϵ' such that

$$(\exists^\infty \sigma \in S_\theta^1 \cap \delta) \epsilon_\sigma = \epsilon'$$

and for such σ we have

$$\epsilon \geq \epsilon' \Rightarrow \eta \upharpoonright \sigma \in A_{\zeta_\epsilon, i_\epsilon, \sigma}$$

and by (2)(d) this implies $\eta \upharpoonright \delta \in A_{\zeta_\epsilon, i_\epsilon, \delta}$.

- $\delta = \text{sup}(\delta \cap S_{\text{inc}})$ but $\delta > \text{sup}(\delta \cap S_\theta^1)$. In this case always really $A_{\zeta_\epsilon, i_\epsilon, \delta} \supseteq \text{set}_0(\Lambda_{\epsilon, \delta}^2)$ because otherwise δ would become a limit in S_ϵ^4 by (g)(3), see below.

Now combine (3.1) and (3.2) to see

$$(\forall \delta \in W)(\exists^\infty \epsilon < \theta) \eta \upharpoonright \delta \in A_{\zeta_\epsilon, i_\epsilon, \delta} \wedge (\zeta_\epsilon, i_\epsilon) \in u_\alpha.$$

Thus $\eta \in A_{u_\alpha}$ and we are done.

How can we carry out the induction?

The only non-explicit part is how to get (g). The idea here is that in (f) we make some mistake because we only cover $\text{set}_0(\Lambda_{\epsilon, \delta}^2)$ modulo $\text{id}^-(\mathbb{Q}_\delta)$, i.e.

$$\text{set}_0(\Lambda_{\epsilon, \delta}^2) \setminus A_{\zeta_\epsilon, i_\epsilon, \delta} = X_{\epsilon, \delta} \in \text{id}^-(\mathbb{Q}_\delta).$$

Let $X_{\epsilon, \delta} = \text{set}_0(\vec{\Gamma}_{\epsilon, \delta})$ where $\vec{\Gamma}_{\epsilon, \delta} = \langle \Gamma_{\epsilon, \delta, \sigma} : \sigma \in S_{\epsilon, \delta} \subseteq \delta \rangle$. So in (g)(3) we want to fix this mistake by choosing some S_ϵ^4 containing both $S_{\epsilon, \delta}$ and S_{ζ_ϵ} and then choosing $\vec{\Lambda}_\epsilon^4$ with all $\Gamma_{\epsilon, \delta, \sigma}$ added. The problem here of course is that we have to do this for all $\delta \in S_\epsilon^3$ but $|S_\epsilon^3| = \kappa$ so fixing the mistake in such a naive way will in general yield a somewhere-stationary set and more than δ -many antichains at level δ . Hence we work as follows: Choose a regressive function f on S_ϵ^3 as in 3.2.6, i.e. such that

$$(\forall \delta < \kappa) |\{\lambda \in S_\epsilon^3 \setminus \delta : f(\lambda) \leq \delta\}| < \delta$$

i.e. f is a regressive but in a very “lazy” way. The problem with fixing our mistakes earlier was that we tried to do it all at once so let us instead do it lazily as dictated by f . Thus let let

$$S_\epsilon^4 = S_\epsilon^3 \cup \bigcup_{\delta \in S_\epsilon^3} S_{\epsilon, \delta} \setminus (f(\delta) + 1)$$

and for $\delta \in S_\epsilon^4$ let

$$\Lambda_{\epsilon, \delta}^4 = \Lambda_{\epsilon, \delta}^3 \cup \{\Gamma_{\epsilon, \delta^*, \delta} : \delta^* > \delta > f(\delta^*)\}$$

Now check that S_ϵ^4 is nowhere stationary.

- $\delta < \sup(S_\epsilon^3 \cap \delta)$. Then $S_\epsilon^3 \cap \delta$ is disjoint from $S_{\epsilon, \delta'} \setminus (f(\delta') + 1)$ for every $\delta' \in S_\epsilon^3$ with $f(\delta') > \delta$ so by 3.2.6(a) the set $S_\epsilon^4 \cap \delta$ is the union of fewer than δ -many non-stationary sets.
- $\delta = \sup(S_\epsilon^3 \cap \delta)$. Let

$$S_{\epsilon, \delta}^{4*} = \bigcup_{\delta' \in S_\epsilon^3 \cap \delta} S_{\epsilon, \delta'} \setminus (f(\delta') + 1)$$

$$S_{\epsilon, \delta}^{4**} = \bigcup_{\delta' \in S_\epsilon^3 \cap (\kappa \setminus \delta)} S_{\epsilon, \delta'} \setminus (f(\delta') + 1) \cap \delta$$

and clearly

$$S_\epsilon^4 \cap \delta = (S_\epsilon^3 \cap \delta) \cup S_{\epsilon, \delta}^{4*} \cup S_{\epsilon, \delta}^{4**}.$$

Let E_δ be as in 3.2.6 and it is easy to check using 3.2.6(b) that $S_{\epsilon, \delta}^{4*}$ is disjoint from E_δ , i.e. non-stationary.

$S_{\epsilon, \delta}^{4**}$ is non-stationary by the argument from the previous point.

Similarly check $|\Lambda_{\epsilon, \delta}^4| \leq \delta$. □

Theorem 3.3.17. *Let κ be Mahlo (or at least S_{pr}^κ stationary).*

- (a) $\text{add}(\text{id}^-(\mathbb{Q}_\kappa)) = \min\{\mu_1, \mu_2\}$.
- (b) $\text{add}(\text{id}(\mathbb{Q}_\kappa)) = \min\{\mu_1, \mu_2, \mu_3\}$.

where

- $\mu_1 = \text{add}(\mathbf{nst}_{\text{pr}}^\kappa)$.
- $\mu_2 = \min(\text{add}(\Pi_S) : S \in \mathbf{nst}_{\text{pr}}^\kappa)$
- $\mu_3 = \text{add}(\text{id}(\mathbb{Q}_\kappa) / \text{id}^-(\mathbb{Q}_\kappa))$.

Proof. The inequality \leq : Same as “ \geq ” in 3.3.16.

The inequality \geq : We only show (a) which using 1.5.5 easily implies (b).

Let $\mu < \mu_1 + \mu_2$ and we are going to show $\mu < \text{add}(\text{id}(\mathbb{Q}_\kappa))$. So let $\langle A_\zeta : \zeta < \mu \rangle$ be a family of $A_\zeta \in \text{id}^-(\mathbb{Q}_\kappa)$ and we are going to find $A \in \text{id}^-(\mathbb{Q}_\kappa)$ such that $\bigcup_{\zeta < \mu} A_\zeta \subseteq A$. Let A_ζ be represented by $\langle A_{\zeta, \delta}^0 : \delta \in S_\zeta^0 \rangle$ and by 3.2.7 we may assume $S_\zeta \in \mathbf{nst}_\kappa^{\text{pr}}$. Now work inductively for $i < \omega$:

1. Let $S^i \in \mathbf{nst}_\kappa^{\text{pr}}$ be such that $\zeta < \mu \Rightarrow S_\zeta^i \subseteq^* S^i$. (Remember $\mu < \mu_1$.)
2. Let $\vec{A}^i \in \Pi_{S^i}$ be such that

$$(\forall \zeta < \mu)(\forall^\infty \delta \in S^i) (A_{\zeta, \delta}^i \subseteq A_\delta^i) \quad \text{mod } \text{id}^-(\mathbb{Q}_\delta).$$

(Remember $\mu < \mu_2$.)

3. For each $\zeta < \mu$ work as in 3.3.16 using a regressive function to fix the error

$$X_{\zeta, \delta}^i = (A_{\zeta, \delta}^i \setminus A_{\delta}^i) \in \text{id}^-(\mathbb{Q}_{\delta}).$$

for $\delta \in S_{\zeta}^i$. I.e., we find $S_{\zeta}^{i+1}, \langle A_{\zeta, \delta}^{i+1} : \delta \in S_{\zeta}^{i+1} \rangle$ such that:

- (a) $S^i \subseteq S_{\zeta}^{i+1} \in \mathbf{nst}_{\kappa}^{\text{pr}}$.
- (b) $\delta \in S_{\zeta}^{i+1} \Rightarrow A_{\zeta, \delta}^{i+1} \in \text{id}(\mathbb{Q}_{\delta})$.
- (c) $\delta \in S_{\zeta}^i \Rightarrow A_{\zeta, \delta}^i \subseteq A_{\delta}^i \cup \text{set}_0^-(\langle A_{\zeta, \epsilon}^{i+1} : \epsilon \in S_{\zeta}^{i+1} \cap \delta \rangle)$.

Let

$$S^{\omega} = \bigcup_{i < \omega} S^i.$$

For $\delta \in S^{\omega}$, $\zeta < \mu$ let

- $A_{\zeta, \delta}^{\omega} = \bigcup_{i < \omega} A_{\zeta, \delta}^i$.
- $A_{\delta}^{\omega} = \bigcup_{i < \omega} A_{\delta}^i$.

Finally let

- $A_{\zeta}^{\omega} = \text{set}_0^-(\langle A_{\zeta, \delta}^{\omega} : \delta \in S^{\omega} \rangle)$.
- $A^{\omega} = \text{set}_0^-(\langle A_{\delta}^{\omega} : \delta \in S^{\omega} \rangle)$.

For $\zeta < \mu$ we claim $A^{\zeta} \subseteq A^{\omega}$. Let $W = S^{\omega} \setminus \alpha^*$ with $\alpha^* < \kappa$ large enough that in all ω -many steps of the construction in (1.) and (2.) the ‘‘almost all’’ quantifiers become ‘‘for all’’.

We now claim that

$$(\forall \delta \in W)(\forall i < \omega) \left(\eta \in A_{\zeta, \delta}^i \Rightarrow \left(\eta \in A_{\delta}^{\omega} \vee (\exists^{\infty} \epsilon \in W \cap \delta) \eta \upharpoonright \epsilon \in A_{\epsilon}^{\omega} \right) \right) \quad (3.3)$$

and clearly this suffices to show $A_{\zeta} \subseteq A^{\omega}$. So towards contradiction assume there exists $\delta^* \in W$ such that there exists $i < \omega$, $\eta^* \in 2^{\delta^*}$ with

$$\eta^* \in A_{\zeta, \delta^*}^i \wedge \eta^* \notin A_{\delta^*}^{\omega} \wedge (\forall^{\infty} \epsilon \in W \cap \delta^*) \eta^* \upharpoonright \epsilon \notin A_{\epsilon}^{\omega} \quad (3.4)$$

and let δ^* be minimal with this property and without loss of generality

$$i = \min\{i : \delta^* \in S_{\zeta}^i\}.$$

Now because $\eta^* \in A_{\zeta, \delta^*}^i$ and $\eta^* \notin A_{\delta^*}^{\omega}$ (thus in particular $\eta^* \notin A_{\delta^*}^i$) so we have

(i) $\eta^* \in X_{\zeta, \delta^*}^i$.

(ii) $\sup(W \cap \delta^*) = \delta^*$.

By (3.)(c) there exists $W^* \subseteq W \cap \delta^*$ unbounded such that

$$(\forall \epsilon \in W^*) \eta^* \upharpoonright \epsilon \in A_{\zeta, \epsilon}^{i+1}$$

and because $W^* \subseteq \delta^*$ and we assumed δ^* to be minimal contradicting formula (3.3) we have

$$(\forall \epsilon \in W^*) \left(\eta \in A_\epsilon^\omega \vee (\exists^\infty \sigma \in W \cap \epsilon) \eta^* \upharpoonright \sigma \in A_\sigma^\omega \right)$$

contradicting the last conjunct of formula (3.4) so we are done.

Intuitively the proof showed: Because κ is well ordered we cannot keep pushing our mistakes in (2.) down for ω -many steps. \square

Corollary 3.3.18. *Let κ be Mahlo (or at least S_{pr}^κ stationary). We get a strengthening of the general fact about ideals from 1.5.5.*

(a) $\text{cf}(\text{id}(\mathbb{Q}_\kappa)) = \text{cf}(\text{id}^-(\mathbb{Q}_\kappa)) + \text{cf}(\text{id}(\mathbb{Q}_\kappa)/\text{id}^-(\mathbb{Q}_\kappa))$

(b) $\text{add}(\text{id}(\mathbb{Q}_\kappa)) = \min\{\text{add}(\text{id}^-(\mathbb{Q}_\kappa)), \text{add}(\text{id}(\mathbb{Q}_\kappa)/\text{id}^-(\mathbb{Q}_\kappa))\}$

Proof.

(a) By 3.3.16.

(b) By 3.3.17 \square

3.4 Strong measure zero sets

Definition 3.4.1. We say $X \subseteq 2^\kappa$ is a *strong measure zero set* if for every $f \in \kappa^\kappa$ there exists a sequence $\langle \eta_\alpha : \alpha < \kappa \rangle$ such that:

1. $\eta_\alpha \in 2^{f(\alpha)}$
2. $X \subseteq \bigcup_{\alpha < \kappa} [\eta_\alpha]$.

Equivalently we may demand

2.' $X \subseteq \bigcap_{\beta < \kappa} \bigcup_{\alpha > \beta} [\eta_\alpha]$.

Lemma 3.4.2. *Let $X \subseteq 2^\kappa$ be strong measure zero. Then $X \in \text{id}^-(\mathbb{Q}_\kappa)$.*

Proof. Let $S \subseteq \kappa$ be nowhere stationary and let $f \in \kappa^\kappa$ be such that $\langle f(\alpha) : \alpha < \kappa \rangle$ enumerates S . Let $\langle \eta_\alpha : \alpha < \kappa \rangle$ be as in 3.4.1 2.' and keep mind that $\{\eta_\alpha\} \in \text{id}(\mathbb{Q}_\alpha)$. Now easily

$$X \subseteq \text{set}_0(\langle \{\eta_\alpha\} : \alpha \in S \rangle) \in \text{id}^-(\mathbb{Q}_\kappa).$$

□

CHAPTER 4

$\text{id}(\mathbb{Q}_\kappa)$ in the \mathbb{Q}_κ -Extension

In this section we consider the relation between \mathbf{V} and $\mathbf{V}^{\mathbb{Q}_\kappa}$, and also more generally between \mathbf{V} and any extension via a strategically closed forcing.

In 4.1 we show that (in contrast to the classical case), the ideal $\text{id}(\mathbb{Q}_\kappa)$ does not satisfy the Fubini theorem, and in fact violates it in a strong sense. This allows us to show $\text{cov}(\mathbb{Q}_\kappa) \leq \text{non}(\mathbb{Q}_\kappa)$, in analogy to the classical inequality $\text{cov}(\text{null}) \leq \text{non}(\text{meager})$. Also, the old reals become a measure zero set in the \mathbb{Q}_κ -extension.

In 4.2, we show that $\mathbb{Q}_\kappa^{\mathbf{V}}$ is \mathbf{V} -completely embedded into $\mathbb{Q}_\kappa^{\mathbf{V}^{\mathbb{Q}_\kappa}}$. This parallels the classical case, but the proof is necessarily different, as we do not have a measure.

4.1 Asymmetry

In this section we elaborate on the asymmetry of $\text{id}(\mathbb{Q}_\kappa)$ as promised in (Shelah 2017). Anti-Fubini sets (defined below) are called 0-1-counterexamples to the Fubini property in (Reclaw and Zakrzewski 1999)

Definition 4.1.1. Let \mathcal{X}, \mathcal{Y} be sets and let $\mathbf{i} \subseteq \mathfrak{P}(\mathcal{X}), \mathbf{j} \subseteq \mathfrak{P}(\mathcal{Y})$ be ideals. We call a set $\mathbf{F} \subseteq \mathcal{X} \times \mathcal{Y}$ an *anti-Fubini set* for (\mathbf{i}, \mathbf{j}) if:

- (a) For all $\eta \in 2^\kappa$ we have $2^\kappa \setminus \mathbf{F}_\eta \in \mathbf{i}$.
- (b) For all $\nu \in 2^\kappa$ we have $\mathbf{F}^\nu \in \mathbf{j}$.

where:

1. $\mathbf{F}_\eta = \{\nu \in 2^\kappa : (\nu, \eta) \in \mathbf{F}\}$.
2. $\mathbf{F}^\nu = \{\eta \in 2^\kappa : (\nu, \eta) \in \mathbf{F}\}$.

If $\mathbf{i} = \mathbf{j}$ then we simply call \mathbf{F} an anti-Fubini set for \mathbf{i} .

Lemma 4.1.2. *Let \mathcal{X}, \mathcal{Y} be sets and let $\mathbf{i} \subseteq \mathfrak{P}(\mathcal{X}), \mathbf{j} \subseteq \mathfrak{P}(\mathcal{Y})$ be ideals. Let $\mathbf{F} \subseteq \mathcal{X} \times \mathcal{Y}$ be such that:*

- (a) *There exists $\mathbf{E}_1 \in \mathbf{j}$ such that for all $\eta \in 2^\kappa \setminus \mathbf{E}_1$ we have $2^\kappa \setminus \mathbf{F}_\eta \in \mathbf{i}$.*
- (b) *There exists $\mathbf{E}_0 \in \mathbf{i}$ such that for all $\nu \in 2^\kappa \setminus \mathbf{E}_0$ we have $\mathbf{F}^\nu \in \mathbf{i}$.*

Then there exists an anti-Fubini set \mathbf{F}' for (\mathbf{i}, \mathbf{j}) .

Proof. Let

$$\mathbf{F}' = \left(\mathbf{F} \cup \left(\mathbf{E}_0 \times (2^\kappa \setminus \mathbf{E}_1) \right) \right) \setminus \left((2^\kappa \setminus \mathbf{E}_0) \times \mathbf{E}_1 \right)$$

and check that \mathbf{F}' is as required. □

Lemma 4.1.3 (Folklore). *Let $\mathbf{i}, \mathbf{j} \subseteq \mathfrak{P}(\mathcal{X})$ be ideals. If there exists an anti-Fubini set \mathbf{F} for (\mathbf{i}, \mathbf{j}) then $\text{cov}(\mathbf{i}) \leq \text{non}(\mathbf{j})$.*

Proof. Suppose $Y \subseteq \mathcal{Y}, Y \notin \mathbf{j}$. We claim that

$$\cup \{2^\kappa \setminus \mathbf{F}_\eta : \eta \in Y\} = \mathcal{X}.$$

Let $\nu \in \mathcal{X}$ be arbitrary. Now because $\mathbf{F}^\nu \in \mathbf{j}$ and $Y \notin \mathbf{j}$ we have $Y \setminus \mathbf{F}^\nu \neq \emptyset$, so choose $\eta_0 \in Y \setminus \mathbf{F}^\nu$. We conclude $\eta_0 \notin \mathbf{F}^\nu \Rightarrow (\nu, \eta_0) \notin \mathbf{F} \Rightarrow \nu \notin \mathbf{F}_{\eta_0}$, so $\nu \in \cup \{2^\kappa \setminus \mathbf{F}_\eta : \eta \in Y\}$. □

Lemma 4.1.4 (Folklore). *Let \mathcal{X} be a set, let $\mathbf{i}, \mathbf{j} \subseteq \mathfrak{P}(\mathcal{X})$ be ideals and let $\otimes : \mathcal{X} \times \mathcal{X} \rightarrow \mathcal{X}$ be a group operation satisfying for all $\mathbf{k} \in \{\mathbf{i}, \mathbf{j}\}$ and for all $X \in \mathbf{k}$:*

- $\eta \otimes X = \{\eta \otimes x : x \in X\} \in \mathbf{k}$.
- $X^{-1} = \{x^{-1} : x \in X\} \in \mathbf{k}$

where x^{-1} denotes the group inverse for \otimes . If there exists sets $A_0, A_1 \subseteq 2^\kappa$ such that:

- (a) $A_0 \in \mathbf{i}$.
- (b) $A_1 \in \mathbf{j}$.
- (c) $A_0 \cap A_1 = \emptyset$.
- (d) $A_0 \cup A_1 = 2^\kappa$.

Then:

- (1) *There exists an anti-Fubini set for (\mathbf{i}, \mathbf{j}) .*
- (2) *There exists an anti-Fubini set for (\mathbf{j}, \mathbf{i}) .*

Proof.

- (1) Let

$$\mathbf{F} = \{(\nu, \eta) : \nu \in \eta \otimes A_1\}.$$

Clearly for any $\eta \in 2^\kappa$ we have $\mathbf{F}_\eta = \eta \otimes A_1$ hence $2^\kappa \setminus \mathbf{F}_\eta = \eta \otimes A_0 \in \mathbf{i}$. For $\nu \in 2^\kappa$ we have $B^\nu = \{\eta : \nu \in \eta \otimes A_1\} = \{\eta : \eta \in \nu \otimes A_1^{-1}\} = \nu \otimes A_1^{-1} \in \mathbf{j}$. So \mathbf{F} is an anti-Fubini set for (\mathbf{i}, \mathbf{j}) .

- (2) Same proof, interchanging A_0 and A_1 . □

Theorem 4.1.5. *Let:*

- (a) $\mathbf{i} = (\mathbb{Q}, \dot{\eta})$ is an ideal case, i.e.
 - (1) \mathbb{Q} is a κ -strategically closed forcing notion (or at least does not add bounded subsets of κ).
 - (2) $\dot{\eta}$ is a \mathbb{Q} -name for a κ -real.
 - (3) The name $\dot{\eta}$ determines \mathbf{i} in the following sense: $A \in \mathbf{i}$ iff there exists a (definition of) a κ -Borel set $\mathbf{B} \supseteq A$ such that $\mathbb{Q} \Vdash \dot{\eta} \notin \mathbf{B}$.
- (b) *There exists an Borel $\mathbf{F} \subseteq 2^\kappa \times 2^\kappa$ that is anti-Fubini for \mathbf{i} both in \mathbf{V} and $\mathbf{V}^{\mathbb{Q}_\kappa}$.*

Then:

- (1) $\mathbb{Q} \Vdash "(2^\kappa)^{\mathbf{V}} \in \mathbf{i}"$.

(2) \mathbb{Q} is asymmetric, i.e. if η_1 is \mathbb{Q} -generic over \mathbf{V} and η_2 is $\mathbb{Q}^{\mathbf{V}[\eta_1]}$ -generic over $\mathbf{V}[\eta_1]$ then η_1 is not \mathbb{Q} -generic over $\mathbf{V}[\eta_2]$.

(3) $\text{cov}(\mathbf{i}) \leq \text{non}(\mathbf{i})$.

Proof.

(1) We want to show:

$$\mathbb{Q} \Vdash \mathbf{V} \cap \mathbf{F}_{\dot{\eta}} = \emptyset.$$

So let $\nu \in 2^\kappa \cap \mathbf{V}$. Consider $\mathbf{F}^\nu = \{\eta : \nu \in \mathbf{F}_\eta\}$. Now because $\mathbf{F}^\nu \in \mathbf{i}$ we have $\dot{\eta} \notin \mathbf{F}^\nu$ thus $\nu \notin \mathbf{F}_{\dot{\eta}}$.

(2) By (1):

$$\mathbf{V}[\eta_1, \eta_2] \Vdash \eta_1 \in 2^\kappa \setminus \mathbf{F}_{\eta_2}.$$

(3) By 4.1.3.

□

Lemma 4.1.6. Assume $\kappa = \text{sup}(S_{\text{inc}}^\kappa)$. Then there exists an anti-Fubini set for $(\text{id}(\mathbb{Q}_\kappa), \text{id}(\mathbb{Q}_\kappa))$.

Discussion 4.1.7. This is implicitly shown in (Shelah 2017) but we repeat it here for the convenience of the reader.

Proof. Let $\langle \delta_\epsilon : \epsilon < \kappa \rangle$ enumerate S_{inc}^κ and let $S = \{\delta_{\epsilon+1} : \epsilon < \kappa\}$. For $\eta \in 2^\kappa, \delta \in S$ define

$$\mathbf{F}_{\eta, \delta} = \{\rho \in 2^\delta : (\forall^\infty \zeta < \delta) \rho(\zeta) = \eta(\delta + \zeta)\}$$

Then clearly $\mathbf{F}_{\eta, \delta} \in \text{id}(\mathbb{Q}_\delta)$. Let

$$\mathbf{F}_\eta = \text{set}_1^- (\langle \mathbf{F}_{\zeta, \delta} : \delta \in S \rangle)$$

so $2^\kappa \setminus \mathbf{F}_\eta \in \text{id}^-(\mathbb{Q}_\kappa)$ by definition. Let

$$\mathbf{F} = \{(\nu, \eta) \in 2^\kappa \times 2^\kappa : \nu \in \mathbf{F}_\eta\}$$

and it remains to check $\mathbf{F}^\nu \in \text{id}(\mathbb{Q}_\kappa)$. Thus let $\nu \in 2^\kappa$ and consider $\mathbf{F}^\nu = \{\eta \in 2^\kappa : \nu \in \mathbf{F}_\eta\}$ and we want to show $\mathbb{Q}_\kappa \Vdash \nu \notin \mathbf{F}_{\dot{\eta}}$. Clearly for every $\zeta < \kappa$ the set

$$\{p \in \mathbb{Q}_\kappa : (\exists \delta \in S \setminus \zeta) (\forall \eta \in [p]) \nu \upharpoonright \delta \in \mathbf{F}_{\eta, \delta}\}$$

is a dense subset of \mathbb{Q}_κ so we are done.

□

4.2 Upwards absoluteness of $\text{id}(\mathbb{Q}_\kappa)$

Lemma 4.2.1 (Mostowski absoluteness). *Let \mathbb{P} be a strategically κ -closed forcing notion and let $T \subseteq \kappa^{<\kappa}$ be a tree, $T \in \mathbf{V}$. If T has a branch of height κ in $\mathbf{V}^{\mathbb{P}}$ then T already has a branch of height κ in \mathbf{V} .*

Proof. Assume there exists $q \in \mathbb{P}$ such that

$$q \Vdash T \text{ has a branch } \dot{\nu} \text{ of height } \kappa.$$

Consider a run of the game $\mathfrak{C}_\kappa(\mathbb{P}, q)$ (as defined in 2.1.4) where for $i < \kappa$ the condition p'_i decides $\dot{\nu} \upharpoonright i = \rho_i$ and White plays according to a winning strategy.

Easily check:

1. $i < \kappa \Rightarrow \rho_i \in T$.
2. $\text{lg}(\rho_i) = i$.
3. $j < i < \kappa \Rightarrow \rho_j \trianglelefteq \rho_i$. [Why? Because $p'_j \geq p'_i$.]

So $\rho = \bigcup_{i < \kappa} \rho_i$ is a branch of height κ of T and $\rho \in \mathbf{V}$. □

Lemma 4.2.2. *Let $\mathcal{J} = \{q_i : i < \kappa\} \subseteq \mathbb{Q}_\kappa$ be a maximal antichain and let \mathbb{P} be a strategically κ -closed forcing notion satisfying the κ^+ -c.c. Then*

$$\mathbb{P} \Vdash \check{\mathcal{J}} \text{ is a maximal antichain of } \mathbb{Q}_\kappa.$$

Proof. Towards contradiction assume there is some $p^* \in \mathbb{P}$ such that

$$p^* \Vdash \check{q} \in \mathbb{Q}_\kappa, \text{ and } (\forall i < \kappa) \check{q} \perp q_i.$$

Without loss of generality even

$$p^* \Vdash \check{q} \text{ is witnessed by } (\dot{\eta}, \dot{S}, \dot{\Lambda}).$$

and even p^* decides $\dot{\eta} = \eta^*$.

Consider a run of the game $\mathfrak{C}(\mathbb{Q}_\kappa, p^*)$ where White plays according to a winning strategy and for $j < \kappa$ we have

$$p'_j \Vdash \dot{S} \cap j = S_j \quad \wedge \quad \dot{\Lambda} \upharpoonright j = \Lambda^j.$$

Let $q^* \in \mathbb{Q}_\kappa$ be the condition witnessed by $(\eta^*, \bigcup_{j < \kappa} S_j, \bigcup_{j < \kappa} \Lambda^j)$. Now $q^* \in \mathbf{V}$ so there is $i < \kappa$ such that $q^* \not\perp q_i$, so one of the following holds:

1. $\text{tr}(q_i) \leq \eta^* \in q_i$
2. $\eta^* \leq \text{tr}(q_i) \in q^*$.

If the first case holds, then “ $\text{tr}(q_i) \leq \eta^* = \text{tr}(\dot{q}) \in q_i$ ” is forced already by p^* ; if the second case holds, then for j large enough $p'_j \Vdash \text{“tr}(q_i) \in q^* \Rightarrow \text{tr}(q_i) \in \dot{q}”$ hence $p'_j \Vdash \text{“}\eta^* = \text{tr}(\dot{q}) \leq \text{tr}(q_i) \in \dot{q}”$, so in either case we have $p'_j \Vdash \dot{q} \not\leq q_i$ for some $j < \kappa$. Contradiction.

Note it easily follows from 2.2.6 that $\bigcup S_j$ is not stationary in κ so q^* is indeed a condition. \square

Corollary 4.2.3. *Let \mathbb{P} be a strategically κ -closed forcing notion satisfying the κ^+ -c.c. Then for every null set of the form $\text{set}_0^-(\langle A_\delta : \delta \in S \rangle)$ in V we also have $\mathbb{P} \Vdash \text{“set}_0^-(\langle A_\delta : \delta \in S \rangle) \in \text{id}(\mathbb{Q}_\kappa)”$, or briefly: “null sets remain null in the generic extension.” \square*

4.3 Miscellaneous

Theorem 4.3.1. *Let $\kappa = \text{sup}(S_{\text{inc}}^\kappa)$. Then $(2^\kappa)^\mathbf{V}$ is a κ -meagre set in $\mathbf{V}^{\mathbb{Q}_\kappa}$.*

Proof. Let $\langle \lambda_i : i < \kappa \rangle$ be an increasing enumeration of S_{inc}^κ . We are going to show that

$$\mathbb{Q}_\kappa \Vdash \text{“For every } \nu \in (2^\kappa)^\mathbf{V} \text{ there exists } i^* < \kappa \text{ such that} \\ i > i^* \Rightarrow \dot{\eta} \upharpoonright (\lambda_i + 1, \lambda_{i+1}) \not\subseteq \nu \text{”}.$$

This suffices by 5.1.2.

Fix $p \in \mathbb{Q}_\kappa$ witnessed by $(\tau, S_1, \vec{\lambda})$ and $\nu \in (2^\kappa)^\mathbf{V}$. We are going to find $q \leq p$ and $i^* < \kappa$ such that

$$q \Vdash i > i^* \Rightarrow \dot{\eta} \upharpoonright (\lambda_i + 1, \lambda_{i+1}) \not\subseteq \nu,$$

Choose i^* such that $\lambda_{i^*} > \text{lg}(\tau)$. Let $S_2 = \{\lambda_{i+1} : i > i^*\}$ and for $\lambda = \lambda_{i+1} \in S_2$ and $\alpha \in (\lambda_i, \lambda_{i+1})$ let

$$\mathcal{J}_{\lambda, \alpha} = \{r \in \mathbb{Q}_\lambda : |\text{tr}(r)| > \alpha, \text{tr}(r) \upharpoonright [\alpha, |\text{tr}(r)|) \not\subseteq \eta\}.$$

Clearly $\mathcal{J}_{\lambda, \alpha}$ is open dense subset of \mathbb{Q}_λ .

Let $S' = S_1 \cup S_2$, let

$$\Lambda'_\lambda = \begin{cases} \Lambda_\lambda & \lambda \in S_1 \setminus S_2 \\ \Lambda_\lambda \cup \{\mathcal{J}_{\lambda,\alpha} : \alpha \in (\lambda_i, \lambda_{i+1})\} & \lambda = \lambda_{i+1} \in S_1 \cap S_2 \\ \{\mathcal{J}_{\lambda,\alpha} : \alpha \in (\lambda_i, \lambda_{i+1})\} & \lambda = \lambda_{i+1} \in S_2 \setminus S_1 \end{cases}$$

and let $\vec{\Lambda}' = \langle \Lambda'_\lambda : \lambda \in S' \rangle$.

Finally let $q \in \mathbb{Q}_\kappa$ be the condition witnessed by $(\tau, S', \vec{\Lambda}')$ and easily check that q is as required. \square

CHAPTER 5

ZFC-Results

5.1 Cichoń's Diagram

Discussion 5.1.1. In this subsection we establish some results about the relation between $\text{id}(\mathbb{Q}_\kappa)$ and the ideal of meager sets $\text{id}(\text{Cohen}_\kappa)$. These theorems are either quotes of or promised elaborations on results first appearing in (Shelah 2017).

Lemma 5.1.2 (Meager set normal form, (Shelah 2017, 5.1)).

(1) Let $X \subseteq 2^\kappa$ be κ -meager and let $S \subseteq \kappa$ be unbounded. Then there exists an increasing sequence $\vec{\alpha} = \langle \alpha_i : i < \kappa \rangle$ of elements of S and $\eta \in 2^\kappa$ such that

$$X \subseteq X_{\eta, \vec{\alpha}} = \{ \nu \in 2^\kappa : (\forall^\infty i < \kappa) \eta \upharpoonright [\alpha_i, \alpha_{i+1}) \neq \nu \upharpoonright [\alpha_i, \alpha_{i+1}) \}.$$

Additionally we may require $\vec{\alpha}$ continuous.

(2) If $\eta \in 2^\kappa$ and $\vec{\alpha}$ is an increasing sequence of ordinals $< \kappa$ then the set $X_{\eta, \vec{\alpha}}$ defined as above is κ -meager.

Proof.

(1) For $i < \kappa$ let $T_i \subseteq 2^{<\kappa}$ be a nowhere dense tree such that $X \subseteq \bigcup_{i < \kappa} [T_i]$. For $\alpha \in S \setminus \omega$ let $\epsilon^* = |2^\alpha|$ and let $\langle (\eta_{\alpha, \epsilon}, i_{\alpha, \epsilon}) : \epsilon < \epsilon^* \rangle$ enumerate $2^\alpha \times \alpha$. Now inductively construct a $\nu_{\alpha, \epsilon}, \beta_{\alpha, \epsilon}$ for $\epsilon \leq \epsilon^*$ such that:

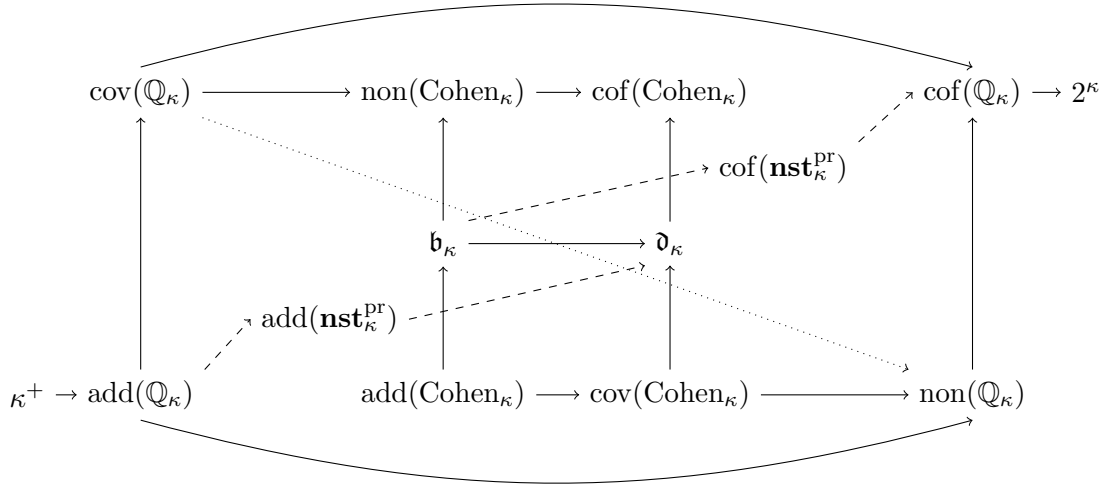

Figure 5.1: The general diagram including $\mathbf{nst}_\kappa^{\text{pr}}$, showing results established in this section. Dashed or dotted arrows have the same meaning as the solid ones but are intended to make the crossing arrows visually less confusing. To prove the implications represented by the dashed arrows (those involving $\text{add}(\mathbf{nst}_\kappa^{\text{pr}})$ and $\text{cf}(\mathbf{nst}_\kappa^{\text{pr}})$) we need to assume that κ is Mahlo (or at least S_{pr}^κ stationary).

- (a) $\beta_{\alpha,\epsilon} \in \kappa$.
- (b) $\langle \beta_{\alpha,\epsilon} : \epsilon < \epsilon^* \rangle$ is increasing continuous.
- (c) $\nu_{\alpha,\epsilon} \in 2^{\beta_{\alpha,\epsilon}}$.
- (d) $\zeta < \epsilon \Rightarrow \nu_{\alpha,\zeta} \trianglelefteq \nu_{\alpha,\epsilon}$.
- (e) $\eta_{\alpha,\epsilon} \hat{\wedge} \nu_{\alpha,\epsilon+1} \notin T_{i_{\alpha,\epsilon}}$.

This can easily be done by starting with $\beta_{\alpha,0} = 0$, $\nu_{\alpha,0} = \langle \rangle$ and for ϵ limit letting $\nu_{\alpha,\epsilon} = \bigcup_{\zeta < \epsilon} \nu_{\alpha,\zeta}$. For ϵ successor use that $T_{i_{\alpha,\epsilon}}$ is nowhere dense.

Construct α_i, ν_i for $i < \kappa$ such that:

- (a) $\alpha_i \in S \setminus \omega$
- (b) $\nu_i \in 2^{\alpha_i}$
- (c) $j < i \Rightarrow \nu_j \trianglelefteq \nu_i$.
- (d) For $i = j + 1$ let $\epsilon^* = |2^{\alpha_j}|$ and let $\alpha_i = \min(S \setminus (\alpha_j + \beta_{\alpha_j, \epsilon^*} + 1))$. Choose $\nu_i \in 2^{\alpha_i}$ such that $\nu_j \hat{\wedge} \nu_{\alpha_j, \epsilon^*} \trianglelefteq \nu_i$.

Check that $\eta = \bigcup_{i < \kappa} \nu_i$ and $\vec{\alpha} = \langle \alpha_i : i < \kappa \rangle$ are as required.

(2) Note that

$$X_{\eta, \vec{\alpha}} = \bigcup_{i^* < \kappa} \{ \nu \in 2^\kappa : (\forall i \in [i^*, \kappa)) \eta \upharpoonright [\alpha_i, \alpha_{i+1}) \neq \nu \upharpoonright [\alpha_i, \alpha_{i+1}) \}.$$

so easily $X_{\eta, \vec{\alpha}}$ is the union of κ -many nowhere dense sets. \square

Lemma 5.1.3. *Let $\vec{\beta}, \vec{\gamma}$ be increasing sequences in κ of length κ such that for every sufficiently large $i < \kappa$ there exists $j < \kappa$ such that $[\beta_j, \beta_{j+1}) \subseteq [\gamma_i, \gamma_{i+1})$. Then $X_{\eta, \vec{\beta}} \subseteq X_{\eta, \vec{\gamma}}$, for any $\eta \in 2^\kappa$.*

Proof. Should be clear. \square

Lemma 5.1.4. *For $\eta \in \kappa^\kappa$ the set*

$$Y_\eta = \{ \nu \in \kappa^\kappa : \nu \leq^* \eta \}$$

is a meager subset of κ^κ .

Proof. Similar to 5.1.2 (2). Again easily Y_η is the union of κ -many nowhere dense sets. \square

Lemma 5.1.5 (Folklore?, (Shelah 2017, 5.3)).

1. $\text{cov}(\text{Cohen}_\kappa) \leq \mathfrak{d}_\kappa$.
2. $\mathfrak{b}_\kappa \leq \text{non}(\text{Cohen}_\kappa)$.
3. $\text{add}(\text{Cohen}_\kappa) \leq \mathfrak{b}_\kappa$.
4. $\mathfrak{d}_\kappa \leq \text{cf}(\text{Cohen}_\kappa)$.

Proof.

1. Let $\langle \eta_i : i < \mathfrak{d}_\kappa \rangle$ be a dominating family. Remember 5.1.4 and easily $\langle Y_{\eta_i} : i < \mathfrak{d}_\kappa \rangle$ is a covering of κ^κ .
2. Let $A = \{ \eta_i : i < \mu < \mathfrak{b}_\kappa \} \subseteq \kappa^\kappa$. Find $\eta \in \kappa^\kappa$ such that for every $i < \mu$ we have $\eta_i \leq^* \eta$. Easily $A \subseteq Y_\eta \in \text{id}(\text{Cohen}_\kappa)$.

3. Let $\langle f_\alpha : \alpha < \mu \rangle$ witness $\mathfrak{b}_\kappa = \mu$. For $\alpha < \mu$ let

$$E_\alpha = \{\delta < \kappa : f[\delta] \subseteq \delta\}$$

and let $\vec{\beta}_\alpha = \langle \beta_{\alpha,i} : i < \kappa \rangle$ enumerate E_α . Let η_0 be constantly 0. Towards contradiction assume that

$$A = \bigcup_{\alpha < \mu} X_{\eta_0, \vec{\beta}_\alpha}$$

is meager. So by 5.1.2 there exist $\eta \in 2^\kappa$, $\vec{\beta} \in \kappa^\kappa$ increasing continuous such that $A \subseteq X_{\eta, \vec{\beta}}$. Let $f \in \kappa^\kappa$ be defined by $f(j) = \beta_{j+1}$. Find $\alpha < \mu$ such that $f_\alpha \not\leq^* f$. Let

$$S = \{j : (\beta_j, \beta_{j+1}] \cap E_\alpha\} = \emptyset.$$

and we claim S is unbounded. Indeed if $\beta_j \leq \beta_{\alpha,i} \leq \beta_{j+1}$ then $j \leq \beta_j < \beta_{\alpha,i} \in E_\alpha$. Hence $f_\alpha(j) < \beta_{\alpha,i} \leq \beta_{j+1} = f(j)$ so by our choice of α the claim follows.

Let $S' \subseteq S$ such that $j \in S' \Rightarrow j+1 \notin S'$ and let $\nu \in 2^\kappa$ be such that $\nu \upharpoonright (\beta_j, \beta_{j+1}] = \eta \upharpoonright (\beta_j, \beta_{j+1}]$ for $j \in S'$ and constantly 1 otherwise. Easily $\nu \in X_{\eta_0, \vec{\beta}_\alpha} \setminus X_{\eta, \vec{\beta}}$. Contradiction to $A \subseteq X_{\eta, \vec{\beta}}$.

4. Let $\langle A_\alpha : \alpha < \mu \rangle$ be cofinal in $\text{id}(\text{Cohen}_\kappa)$. For $\alpha < \mu$ use 5.1.2 to find $\eta_\alpha, \beta_\alpha$ such that $A_\alpha \subseteq X_{\eta_\alpha, \vec{\beta}_\alpha}$. Let

$$E_\alpha = \{\delta : i < \delta \Rightarrow \beta_{\alpha,i} < \delta\}$$

Towards contradiction assume that $\mathfrak{d}_\kappa > \mu$. Then by 5.2.4 there exists a club E such that for every α we have $E_\alpha \not\subseteq^* E$. Let $\eta_0 \in 2^\kappa$ and let $\vec{\beta}$ enumerate E . Consider $X_{\eta_0, \vec{\beta}}$ and find α such that $X_{\eta_0, \vec{\beta}} \subseteq X_{\eta_\alpha, \vec{\beta}_\alpha}$.

If $\delta \in E_\alpha \setminus E$ we have $\epsilon = \sup(E \cap \delta) < \delta$ because E is club. Let $i = \epsilon + 1$ and note that $\beta_{\alpha,i} < \delta$. Hence $(\beta_{\alpha,i}, \delta] \cap E = \emptyset$ so argue as in (3.) to get a contradiction. \square

Fact 5.1.6 (Folklore?, (Shelah 2017, 5.3)).

1. $\text{add}(\text{Cohen}_\kappa) = \min(\mathfrak{b}_\kappa, \text{cov}(\text{Cohen}_\kappa))$.
2. $\text{cf}(\text{Cohen}_\kappa) = \max(\mathfrak{d}_\kappa, \text{non}(\text{Cohen}_\kappa))$.

Proof.

1. By 5.1.5 2. and 3. it suffices to show

$$\text{add}(\text{Cohen}_\kappa) \geq \min\{\mathfrak{b}_\kappa, \text{cov}(\text{Cohen}_\kappa)\}.$$

Let $\mu = \text{add}(\text{Cohen}_\kappa)$ and towards contradiction assume $\mu < \mathfrak{b}_\kappa, \mu < \text{cov}(\text{Cohen}_\kappa)$.

Let $\mathcal{A} = \{A_\gamma : \gamma, \mu\}$ be a family of meager sets such that $\bigcup \mathcal{A} \not\subseteq \text{id}(\text{Cohen}_\kappa)$.

For $\gamma < \mu$ let $\eta_\gamma, \vec{\beta}_\gamma$ be such that $A_\gamma \subseteq X_{\eta_\gamma, \vec{\beta}_\gamma}$ (as in 5.1.2). Let let

$$E_\gamma = \{\alpha < \kappa : (\forall i < \alpha) \beta_{\gamma, i} < \alpha\}.$$

Use $\mu < \mathfrak{b}_\kappa$ to find a club $E \subseteq \kappa$ such that $E \subseteq^* E_\gamma$ for all $\gamma < \mu$ (remember 5.2.3) and let $\vec{\beta} = \langle \beta_i : i < \kappa \rangle$ enumerate E . By 5.1.3 we have $A_\gamma \subseteq X_{\eta_\gamma, \vec{\beta}_\gamma} \subseteq X_{\eta_\gamma, \vec{\beta}}$.

Using $\mu < \text{cov}(\text{Cohen})$ we find $\nu \in 2^\kappa$ such that:

$$(\forall \gamma < \mu) Z_\gamma = \{j < \kappa : \eta_\gamma \upharpoonright [\beta_j, \beta_{j+1}) = \nu \upharpoonright [\beta_j, \beta_{j+1})\} \text{ is cofinal in } \kappa.$$

Use $\mu < \mathfrak{b}_\kappa$ to find $\vec{\alpha}$ such that

$$(\forall \gamma < \mu) (\forall^* i < \kappa) Z_\gamma \cap [\alpha_i, \alpha_{i+1}) \neq \emptyset.$$

Let for $i < \kappa$, $\delta_i = \beta_{\alpha_i}$ easily for each $\gamma < \mu$ we have $X_{\eta_\gamma, \vec{\beta}} \subseteq X_\nu, \vec{\delta}$. Contradiction.

2. By 5.1.5 1. and 4. is suffices to show

$$\text{cf}(\text{Cohen}_\kappa) \leq \mathfrak{d}_\kappa + \text{non}(\text{Cohen}_\kappa).$$

Let $\mu = \text{non}(\text{Cohen}_\kappa)$.

Let $\{\varrho_\beta : \beta < \mu\} \subseteq \kappa^\kappa$ be such that

$$(\forall \nu \in \kappa^\kappa) (\exists \beta < \mu) (\exists^\infty i < \kappa) \varrho_\beta(i) = \nu(i).$$

[Why possible? For $\rho \in 2^\kappa$ let $\nu_\rho \in \kappa^\kappa$ such that for $i < \kappa$, $\nu_\rho(i)$ is the minimal $\gamma < \kappa$ such that $\rho(i + \gamma) = 1$ if such γ exists, otherwise $\nu_\rho(i) = 0$. Let $\nu_0 \in \kappa^\kappa$ be constantly 0. Let $M \subseteq 2^\kappa$ be a non-meager set of cardinality μ . Recalling 5.1.2 the set $\{\nu_\rho : \rho \in M\} \cup \{\nu_0\}$ is as required.]

Let $\langle E_\gamma : \gamma < \mathfrak{d}_\kappa \rangle$ be a sequence of clubs witnessing \mathfrak{d}_κ in the sense of 5.2.4.

Let $\vec{\alpha}_\gamma = \langle \alpha_{\gamma,i} : i < \kappa \rangle$ enumerate E_γ .

Let $\langle \rho_i : i < \kappa \rangle$ enumerate $\bigcup \{2^{[j,k]} : j < k < \kappa\}$. For $(\beta, \gamma, \xi) \in \mu \times \mathfrak{d}_\kappa \times \mathfrak{d}_\kappa$ let $A_{\beta,\gamma,\xi} = X_{\varrho_{\beta,\gamma,\xi}}$ as in 5.1.2 where for $\beta < \mu, \gamma < \mathfrak{d}_\kappa$ we let $\varrho_{\beta,\gamma}$ be such that $\varrho_{\beta,\gamma} \upharpoonright [\alpha_{\gamma,i}, \alpha_{\gamma,i+1})$ is equal to $\rho_{\varrho_\beta(i)}$ if $\rho_{\varrho_\beta(i)} \in 2^{[\alpha_{\gamma,i}, \alpha_{\gamma,i+1})}$, otherwise $\varrho_{\beta,\gamma}$ is constantly 0.

Let $\mathcal{A} = \{A_{\beta,\gamma,\xi} : (\beta, \gamma, \xi) \in \mu \times \mathfrak{d}_\kappa \times \mathfrak{d}_\kappa\}$ and we claim \mathcal{A} is cofinal in $\text{id}(\text{Cohen}_\kappa)$. Clearly $|\mathcal{A}| = \mu + \mathfrak{d}_\kappa$ so this suffices. To prove the claim let $A \in \text{id}(\text{Cohen}_\kappa)$ and let $\eta \in 2^\kappa, \vec{\alpha} \in \kappa^\kappa$ be such that $A \subseteq X_{\eta, \vec{\alpha}}$.

Find $\gamma(1) < \mathfrak{d}_\kappa$ such that

$$E_{\gamma(1)} \subseteq \{\alpha < \kappa : (\forall i < \alpha) \alpha_i < \alpha\}$$

and clearly $A \subseteq X_{\eta, \vec{\alpha}} \subseteq X_{\eta, \vec{\alpha}_{\gamma(1)}}$ (by 5.1.3). Let $\varrho \in \kappa^\kappa$ be such that for $i < \kappa$, $\rho(\varrho(i)) = \eta \upharpoonright [\alpha_{\gamma(1),i}, \alpha_{\gamma(1),i+1})$. Find $\beta < \mu$ such that $B = \{i < \kappa : \varrho(i) = \varrho_\beta(i)\}$ is cofinal in κ . Find $\gamma(2) < \mathfrak{d}_\kappa$ such that

$$E_{\gamma(2)} \subseteq \{\alpha \in E_{\gamma(1)} : (\forall i < \kappa) \alpha_{\gamma(1),i} < \alpha\}$$

and $[\alpha_{\gamma(2),i}, \alpha_{\gamma(2),i+1}) \cap B \neq \emptyset$. Now check that indeed $A \subseteq A_{\beta,\gamma(1),\gamma(2)}$. \square

Theorem 5.1.7 ((Shelah 2017, 3.8)). *Let $\kappa = \text{sup}(S_{\text{inc}}^\kappa)$. Then there exist sets $N, M \subseteq 2^\kappa$ such that $N \in \text{id}(\mathbb{Q}_\kappa)$, $M \in \text{id}(\text{Cohen}_\kappa)$, $N \cap M = \emptyset$ and $N \cup M = 2^\kappa$.*

Proof. Let $\langle \lambda_i : i < \kappa \rangle$ be an increasing enumeration of S_{inc}^κ . For $i < \kappa$ let

$$\mathcal{J}_{\lambda_{i+1}} = \{p \in \mathbb{Q}_{\lambda_{i+1}} : \text{lg}(\text{tr}(p)) > \lambda_i \wedge \text{tr}(p) \upharpoonright [\lambda_i, \text{lg}(\text{tr}(p))) \text{ is not constantly } 0\}.$$

For $\eta \in 2^{<\kappa}$ let $p_\eta \in \mathbb{Q}_\kappa$ be the condition witnessed by

$$(\eta, \{\lambda_{i+1} : i < \kappa, \lambda_{i+1} > \text{lg}(\eta)\}, \langle \{D_{\lambda_{i+1}}\} : i < \kappa, \lambda_{i+1} > \text{lg}(\eta) \rangle).$$

It is easy to see that $[p_\eta]$ is a nowhere dense subset of 2^κ . Hence for

$$M = \bigcup_{\eta \in 2^{<\kappa}} [p_\eta]$$

we have $M \in \text{id}(\text{Cohen}_\kappa)$.

Let $N = 2^\kappa \setminus M$. It remains to check that $N \in \text{id}(\mathbb{Q}_\kappa)$. Indeed for any $p \in \mathbb{Q}_\kappa$ let $\eta = \text{tr}(p)$ and let q be a lower bound for p, p_η . Now $q \Vdash \dot{\eta} \in [q] \subseteq [p_\eta] \subseteq M$, i.e. $q \Vdash \dot{\eta} \notin N$. \square

Corollary 5.1.8. *Let $\kappa = \sup(S_{\text{inc}}^\kappa)$. Then:*

- (1) $\text{cov}(\text{Cohen}_\kappa) \leq \text{non}(\mathbb{Q}_\kappa)$.
- (2) $\text{cov}(\mathbb{Q}_\kappa) \leq \text{non}(\text{Cohen}_\kappa)$.

Proof. Let \oplus be pointwise addition modulo 2. In by 5.1.7 for $\kappa = \sup(S_{\text{inc}}^\kappa)$ there exist sets $N \in \text{id}(\mathbb{Q}_\kappa)$, $M \in \text{id}(\text{Cohen}_\kappa)$ satisfying 4.1.4(a)–(d) so the conclusion follows by 4.1.3. \square

Corollary 5.1.9. *Let $\kappa = \sup(S_{\text{inc}}^\kappa)$. Then:*

- (1) $\text{cov}(\text{id}^-(\mathbb{Q}_\kappa)) \leq \text{non}(\text{id}(\mathbb{Q}_\kappa))$
- (2) and in particular $\text{cov}(\mathbb{Q}_\kappa) \leq \text{non}(\mathbb{Q}_\kappa)$.

Proof. By 4.1.5 and 4.1.6. \square

Lemma 5.1.10. *Let κ be inaccessible (or $\kappa = \omega$). Then there exists a partition $\langle A_i : i < |2^\kappa| \rangle$ such that each A_i is non-meager and for every $\eta \in 2^{<\kappa}$ also $A_i \cap [\eta]$ is non-meager.*

Proof. First note that because κ is inaccessible we have $|2^{<\kappa}| = \kappa$. Thus let $\langle \eta_k : k < \kappa \rangle$ be an enumeration of $2^{<\kappa}$. Let $\mathfrak{c}_\kappa = |2^\kappa|$. Let $\langle X_j : j < \mathfrak{c}_\kappa \rangle$ be an enumeration of all closed nowhere dense subsets of 2^κ . Let $\langle (i_\epsilon, j_\epsilon, k_\epsilon) : \epsilon < \mathfrak{c}_\kappa \rangle$ be an enumeration of $\mathfrak{c}_\kappa \times \mathfrak{c}_\kappa \times \kappa$. Now for $\epsilon < \mathfrak{c}_\kappa$ inductively choose $\nu_\epsilon \in 2^\kappa$ such that

1. $\nu_\epsilon \notin \bigcup_{\zeta < \epsilon} \{\nu_\zeta\}$.
2. $\nu_\epsilon \notin X_{j_\epsilon}$
3. $\nu_\epsilon \in [\eta_{k_\epsilon}]$

[Why can we carry out this construction? Because for every nowhere dense set X and every $\eta \in 2^\kappa$ there exists $\eta' \supseteq \eta$ such that $[\eta']$ and X are disjoint and of course $|[\eta']| = \mathfrak{c}_\kappa$.]

Let $A_0 = \{\nu_\epsilon : i_\epsilon = 0\} \cup (2^\kappa \setminus \{\nu_\epsilon : \epsilon < \kappa\})$. For $i > 0$ let $A_i = \{\nu_\epsilon : i_\epsilon = i\}$. Now check that by construction $\langle A_i : i < \mathfrak{c}_\kappa \rangle$ is as required. \square

Theorem 5.1.11 ((Shelah 2017, 5.5)). *If $\mathfrak{b}_\kappa > \text{add}(\text{Cohen}_\kappa)$ then $\text{cov}(\mathbb{Q}_\kappa) \leq \text{add}(\text{Cohen}_\kappa)$.*

Proof. If $\kappa > \text{sup}(S_{\text{inc}}^\kappa)$ then $\text{cov}(\mathbb{Q}_\kappa) = \text{cov}(\text{Cohen}_\kappa)$.

So assume $\kappa = \text{sup}(S_{\text{inc}}^\kappa)$. Let $\mu = \text{cov}(\text{Cohen}_\kappa)$ and assume towards contradiction that $\mu < \text{cov}(\mathbb{Q}_\kappa)$.

Let $\langle X_{\eta_\epsilon, \vec{\alpha}_\epsilon} : \epsilon < \mu \rangle$ be a covering of 2^κ (remember 5.1.2).

Our first goal is to find a single $\vec{\alpha}$ such that $X_{\eta_\epsilon, \vec{\alpha}_\epsilon} \subseteq X_{\eta_\epsilon, \vec{\alpha}}$ for every $\epsilon < \mu$. We define f_ϵ such that $f_\epsilon(i) = \alpha_\epsilon(j_i + 1)$ where $j_i = \min\{j < \kappa : \alpha_\epsilon(j) > i\}$, hence $[\alpha_\epsilon(j_i), \alpha_\epsilon(j_i + 1)] \subseteq [i, f_\epsilon(i)]$. By our assumption $\mu < \mathfrak{b}_\kappa$ we find $f \geq^* f_\epsilon$ for every $\epsilon < \mu$. So for every $\epsilon < \mu$ and i sufficiently large we $[\alpha_\epsilon(j_i), \alpha_\epsilon(j_i + 1)] \subseteq [i, f_\epsilon(i)] \subseteq [i, f(i)]$. Thus define $\vec{\alpha}$ inductively by

1. $\alpha_0 = 0$
2. $\alpha_{i+1} = f(\alpha_i)$
3. $\alpha_i = \sup_{j < i} \alpha_j$ for i limit.

Now $\vec{\alpha}$ is indeed as required by 5.1.3.

Our second goal is to find an increasing sequence $\vec{\theta} = \langle \theta_\epsilon : \epsilon < \kappa \rangle$ such that there is $\Upsilon \subseteq \prod_{\epsilon < \kappa} \theta_\epsilon = \Pi\theta$, $|\Upsilon| = \mu$ such that

$$(\forall \nu \in \Pi\theta) (\exists \rho \in \Upsilon) (\forall^\infty \epsilon < \kappa) \nu(\epsilon) \neq \rho(\epsilon).$$

Without loss of generality $\vec{\alpha}$ satisfies

$$i < j \rightarrow |2^{[\alpha_\epsilon, \alpha_{\epsilon+1}]}| < |2^{[\alpha_\zeta, \alpha_{\zeta+1}]}|,$$

otherwise inductively join sufficiently many intervals (and use 5.1.3). Let $\theta_\epsilon = |2^{[\alpha_\epsilon, \alpha_{\epsilon+1}]}|$ and let $\pi_\epsilon : 2^{[\alpha_\epsilon, \alpha_{\epsilon+1}]} \rightarrow \theta_\epsilon$ be one-to-one. Now it is easy to see that

$$\Upsilon = \{\langle \pi_\epsilon(\eta_i \upharpoonright [\alpha_\epsilon, \alpha_{\epsilon+1}]) : \epsilon < \kappa \rangle : i < \mu\}$$

is as required.

By induction on $\epsilon < \kappa$ we choose an increasing sequence of inaccessible λ_ϵ such that $\lambda_\epsilon \geq \theta_\epsilon$ and $\text{sup}(S_{\text{inc}}^{\lambda_\epsilon}) < \lambda_\epsilon$.

Next for $\epsilon < \kappa$ let $\langle A_{\epsilon, i} : i < \theta_\epsilon \rangle$ be a partition of 2^{λ_ϵ} as in 5.1.10.

Let $\dot{\nu} \in \kappa^\kappa$ be a name for the such $\nu(\epsilon)$ is the unique $i < \theta_\epsilon$ such that $\dot{\eta} \upharpoonright \lambda_i \in A_{\epsilon, i}$. (As always $\dot{\eta}$ is the name for the generic real added by \mathbb{Q}_κ). Note $\dot{\nu}$ is well defined because \mathbb{Q}_κ is κ -strategically closed, hence $(2^{\lambda_i})^\mathbf{V} = (2^{\lambda_i})^{\mathbf{V}[\mathbb{Q}_\kappa]}$.

We claim that for $\rho \in \Pi\theta$ we have

$$\mathbb{Q}_\kappa \Vdash (\exists^\infty \epsilon < \kappa) \dot{\nu}(\epsilon) = \rho(\epsilon).$$

Let $\alpha < \kappa$, $p \in \mathbb{Q}_\kappa$, $\tau = \text{tr}(p)$. We find $\epsilon < \kappa$ such that $\epsilon > \alpha$, $\lambda_\epsilon > \text{lg}(\tau)$. $\tau' \in 2^{\text{sup}(S_{\text{inc}}^{\lambda_\epsilon})} \cap p$. Choose $\tau'' \in [\tau'] \cap A_{\epsilon, \rho(\epsilon)} \cap p$. [Why does τ'' exist? Trivial if $\lambda_\epsilon \notin S_p$. If $\lambda_\epsilon \in S_p$ then $Z = \text{set}_0(\Lambda_{p, \lambda_\epsilon})$ is λ_ϵ -meager hence $Z \cap [\tau']$ is λ_ϵ -meager hence $Z \cap [\tau'] \neq [\tau'] \cap A_{\epsilon, \rho(\epsilon)}$.] Clearly $p^{[\tau'']} \Vdash \dot{\nu}(\epsilon) = \rho(\epsilon)$. The claim easily follows.

Thus for $\rho \in \Upsilon$, $\alpha < \kappa$ the set

$$\mathcal{I}_{\rho, \alpha} = \{p \in \mathbb{Q}_\kappa : (\exists \epsilon < \kappa) \alpha < \lambda_\epsilon \leq \text{lg}(\text{tr}(p)) \wedge \text{tr}(p) \upharpoonright \lambda_\epsilon \in A_{\epsilon, \rho(\epsilon)}\}$$

is open dense.

By our assumption $|\Upsilon| = \mu < \text{cov}(\mathbb{Q}_\kappa)$ there exists

$$\eta \in \bigcap_{\rho \in \Upsilon} \text{set}_1(\{\mathcal{I}_{\rho, \alpha} : \alpha < \kappa\}).$$

Let $\nu \in \Pi\theta$ be such that for $\epsilon < \kappa$ we have $\eta \upharpoonright \lambda_\epsilon \in A_{\epsilon, \nu(\epsilon)}$. Note by our choice of ν and $\rho \in \Upsilon$ we have

$$(\exists^\infty \epsilon < \kappa) \eta \upharpoonright \lambda_\epsilon = A_{\epsilon, \rho(\epsilon)}.$$

Thus

$$(\exists \nu \in \Pi\theta)(\forall \rho \in \Upsilon)(\exists^\infty \epsilon < \kappa) \nu(\epsilon) = \rho(\epsilon).$$

Contradiction. □

$$\begin{array}{ccccc}
 \text{non}(\text{Cohen}_\kappa) & \longrightarrow & \text{cof}(\text{Cohen}_\kappa) & & \text{cof}(\mathbb{Q}_\kappa) \longrightarrow 2^\kappa \\
 \uparrow & & \uparrow & & \uparrow \\
 \mathfrak{b}_\kappa & \longrightarrow & \mathfrak{d}_\kappa & & \\
 \uparrow \neq & & \uparrow & & \\
 \kappa^+ \rightarrow \text{add}(\mathbb{Q}_\kappa) \rightarrow \text{cov}(\mathbb{Q}_\kappa) \rightarrow \text{add}(\text{Cohen}_\kappa) = \text{cov}(\text{Cohen}_\kappa) \rightarrow \text{non}(\mathbb{Q}_\kappa)
 \end{array}$$

Figure 5.2: The diagram for $\text{add}(\text{Cohen}_\kappa) < \mathfrak{b}_\kappa$, by 5.1.11.

Theorem 5.1.12 ((Shelah 2017, 5.7)). *If $\mathfrak{d}_\kappa < \text{cf}(\text{Cohen}_\kappa)$ then $\text{cf}(\text{Cohen}_\kappa) \leq \text{non}(\mathbb{Q}_\kappa)$.*

Proof. If $\kappa > \text{sup}(S_{\text{inc}}^\kappa)$ then $\text{non}(\mathbb{Q}_\kappa) = \text{non}(\text{Cohen}_\kappa)$.

So assume $\kappa = \text{sup}(S_{\text{inc}}^\kappa)$. For $\vec{\theta} = \langle \theta_\epsilon : \epsilon < \kappa \rangle$, $\theta_\epsilon < \kappa$ increasing with ϵ , find $\langle \lambda_{\theta,\epsilon} : \epsilon < \kappa \rangle$ and $\langle A_{\theta,\epsilon,i} : i < \theta_\epsilon \rangle$ as in 5.1.11.

For $\vec{\theta}$ as above, $\eta \in 2^\kappa$ let $\nu_{\theta,\eta} \in \Pi\theta$ be such that for every $\epsilon < \kappa$ we have $\eta \upharpoonright \lambda_{\theta,\epsilon} \in A_{\theta,\epsilon,\nu_{\theta,\eta}(\epsilon)}$.

Let $\Upsilon \subseteq 2^\kappa$, $|\Upsilon| = \text{non}(\mathbb{Q}_\kappa)$. For any $\vec{\theta}$ as above let $\Upsilon_\theta = \{\nu_{\theta,\eta} : \eta \in \Upsilon\} \subseteq \Pi\theta$. Clearly $|\Upsilon_\theta| \leq \text{non}(\mathbb{Q}_\kappa)$.

We claim that for every

$$(\forall \rho \in \Pi\theta)(\exists \nu \in \Upsilon_\theta)(\exists^\infty \epsilon < \kappa) \rho(\epsilon) = \nu(\epsilon).$$

So fix $\rho \in \Pi\theta$ and let

$$\mathcal{I}_\alpha = \{p \in \mathbb{Q}_\kappa : (\exists \epsilon < \kappa) \alpha < \lambda_{\theta,\epsilon} \leq \text{lg}(\text{tr}(p)) \wedge \text{tr}(p) \upharpoonright \lambda_{\theta,\epsilon} \in A_{\theta,\epsilon,\rho(\epsilon)}\}.$$

Because $\Upsilon \notin \text{id}(\mathbb{Q}_\kappa)$ we can find $\eta \in \Upsilon \cap \text{set}_1(\{\mathcal{I}_\alpha : \alpha < \kappa\})$. Now

$$(\exists^\infty \epsilon < \kappa) \nu_{\theta,\eta}(\epsilon) = \rho(\epsilon)$$

which proves the claim.

Find $\{\vec{\alpha}_\xi : \xi < \mathfrak{d}_\kappa\}$ such that:

- (a) For $\xi < \mathfrak{d}_\kappa$ the sequence $\vec{\alpha}_\xi = \langle \alpha_{\xi,\epsilon} : \epsilon < \kappa \rangle$ is continuous increasing.
- (b) If $\langle \alpha_i : i < \kappa \rangle$ is an increasing sequence then there is $\xi < \mathfrak{d}_\kappa$ such that

$$(\forall^\infty \epsilon < \kappa)(\exists i < \kappa) \alpha_{\xi,\epsilon} < \alpha_i < \alpha_{i+1} < \alpha_{\xi,\epsilon+1}.$$

For $\xi < \mathfrak{d}_\kappa$ let $\vec{\theta}_\xi = \langle \theta_{\xi,\epsilon} : \epsilon < \kappa \rangle$ be such that $\theta_{\xi,\epsilon} = |2^{[\alpha_{\xi,\epsilon}, \alpha_{\xi,\epsilon}]}|$. As in 5.1.11 let $\pi_{\xi,\epsilon} : \theta_{\xi,\epsilon} \rightarrow 2^{[\alpha_{\xi,\epsilon}, \alpha_{\xi,\epsilon}]}$ be one-to-one. For $\nu \in \Pi\theta_\xi$ let

$$x_{\xi,\nu} = \bigcup_{\epsilon < \kappa} \pi_{\xi,\epsilon}(\nu(\epsilon)) \in 2^\kappa.$$

Let

$$H = \{x_{\xi,\nu} : \xi < \mathfrak{d}_\kappa \wedge \nu \in \Upsilon_{\theta_\xi}\}$$

and we claim $H \notin \text{id}(\text{Cohen}_\kappa)$. Towards contradiction assume that there exists $\eta \in 2^\kappa$, $\vec{\alpha} = \langle \alpha_i : i < \kappa \rangle$ increasing continuous such that $H \subseteq X_{\eta,\vec{\alpha}}$ (remember 5.1.7). Let $\xi < \mathfrak{d}_\kappa$ be given by (b) for $\vec{\alpha}$. Let $\rho \in \Pi\theta_\xi$ be such that $\pi_{\xi,\epsilon}(\rho(\epsilon)) =$

$\eta \upharpoonright [\alpha_{\xi,\epsilon}, \alpha_{\xi,\epsilon+1})$. So there exists $\nu \in \Upsilon_{\theta_\xi}$ such that $(\exists^\infty \epsilon < \kappa) \rho(\epsilon) = \nu(\epsilon)$. Thus $(\exists^\infty \epsilon < \kappa) x_{\xi,\nu} \upharpoonright [\alpha_{\xi,\epsilon}, \alpha_{\xi,\epsilon+1}) = \eta \upharpoonright [\alpha_{\xi,\epsilon}, \alpha_{\xi,\epsilon+1})$ and finally (by our choice of ξ) $(\exists^\infty \epsilon < \kappa) x_{\xi,\nu} \upharpoonright [\alpha_{\xi,o}, \alpha_{\xi,o+1}) = \eta \upharpoonright [\alpha_{\xi,i}, \alpha_{\xi,i+1})$. Contradiction to $x_{\xi,\nu} \in X_{\eta,\vec{\alpha}}$.

Thus by

$$\mathfrak{d}_\kappa < \text{non}(\text{Cohen}_\kappa) \leq |H| \leq \text{non}(\mathbb{Q}_\kappa) + \mathfrak{d}_\kappa$$

we conclude $\text{non}(\text{Cohen}_\kappa) \leq \text{non}(\mathbb{Q}_\kappa)$. \square

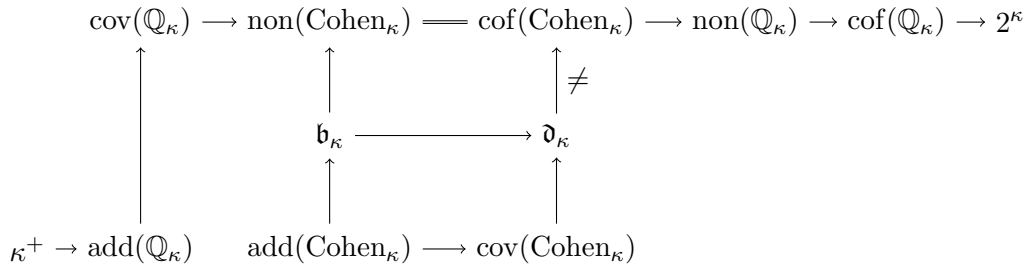

Figure 5.3: The diagram for $\mathfrak{d}_\kappa < \text{cof}(\text{Cohen})_\kappa$, by 5.1.12.

5.2 On $\text{add}(\mathbb{Q}_\kappa) \leq \text{add}(\text{Cohen}_\kappa)$

Discussion 5.2.1. For the classical case ($\kappa = \omega$) the Bartoszyński-Raisonnier-Stern theorem states that $\text{add}(\text{null}) \leq \text{add}(\text{meager})$. By 5.1.11 we know that $\text{add}(\mathbb{Q}_\kappa) \leq \text{add}(\text{Cohen}_\kappa)$ for large \mathfrak{b}_κ and dually $\text{cf}(\text{Cohen}_\kappa) \leq \text{add}(\mathbb{Q}_\kappa)$ for small \mathfrak{d}_κ . But what about small \mathfrak{b}_κ , i.e. $\text{add}(\text{Cohen}_\kappa) = \mathfrak{b}_\kappa$ and large \mathfrak{d}_κ , i.e. $\mathfrak{d}_\kappa = \text{cf}(\text{Cohen}_\kappa)$?

The original plan for this case was to first prove $\text{add}(\mathbb{Q}_\kappa) \leq \text{add}(\mathbf{nst}_\kappa^{\text{pr}})$ (see 3.3.6) and show that $\text{add}(\mathbf{nst}_\kappa^{\text{pr}}) \leq \mathfrak{b}_\kappa$. We conjecture that this second inequality does not hold (see 5.2.13). In (Shelah 2017) it was shown that we have it at least for sufficiently weak κ (there exists a stationary non-reflecting subset of κ) and here we elaborate on this result as promised.

Furthermore we offer a consolation prize: we show that at least $\text{add}(\mathbb{Q}_\kappa) \leq \mathfrak{d}_\kappa$ for κ Mahlo and dually $\mathfrak{b}_\kappa \leq \text{cf}(\mathbb{Q}_\kappa)$.

We begin by establishing a characterization of \mathfrak{b}_κ and \mathfrak{d}_κ via characteristics of the club filter of κ .

Lemma 5.2.2. *Consider $\mathbf{A} = (\kappa^\kappa, \leq^*)$ and $\mathbf{B} = (\text{club}_\kappa, \supseteq^*)$. Then there exist maps $\phi^+ : \kappa^\kappa \rightarrow \text{club}_\kappa$ and $\phi^- : \text{club}_\kappa \rightarrow \kappa^\kappa$ such that*

1. (ϕ^-, ϕ^+) is a morphism from \mathbf{A} to \mathbf{B} , i.e. if $f \in \kappa^\kappa$ and $E \in \text{club}_\kappa$ then:

$$\phi^-(E) \leq^* f \quad \Rightarrow \quad E \supseteq^* \phi^+(f).$$

2. (ϕ^+, ϕ^-) is a morphism from \mathbf{B} to \mathbf{A} , i.e. if $f \in \kappa^\kappa$ and $E \in \text{club}_\kappa$ then:

$$\phi^+(f) \supseteq^* E \quad \Rightarrow \quad f \leq^* \phi^-(E).$$

Proof. For $f \in \kappa^\kappa$ let

$$\phi^+(f) = \{\delta < \kappa : f[\delta] \subseteq \delta\}.$$

For $E \in \text{club}_\kappa$ let

$$\phi^-(E) = i \mapsto \lceil i + 1 \rceil^E = \min(E \setminus (i + 2)).$$

1. Let $f \in \kappa^\kappa$, $E' \in \text{club}_\kappa$. Let $E = \phi^+(f)$, $f' = \phi^-(E')$. Assume $E' \not\supseteq^* E$. So there exist κ -many $\delta \in E \setminus E'$. Now for any such δ : Because E' is club $\epsilon = \sup(E' \cap \delta) < \delta$. Consider $i \in (\epsilon, \delta)$. By definition of E we have $f(i) < \delta$ but because $(\delta, \epsilon] \cap E' = \emptyset$ by definition of f' we have $f'(i) > \delta$. Thus $f'(i) > f(i)$ and because there are unboundedly many such δ we have $f' \not\leq^* f$.
2. Let $E \in \kappa^\kappa$, $f' \in \text{club}_\kappa$. Let $E' = \phi^+(f')$, $f = \phi^-(E)$. Assume $E' \not\supseteq^* E$. Consider $i < \kappa$ large enough. Then $f(i) \in E$ implies $f(i) \in E'$. By definition of E' we have $f'(i) < f(i)$. Hence $f' \not\leq^* f$.

□

Lemma 5.2.3.

- (1) Let $\langle E_\alpha : \alpha < \mu < \mathfrak{b}_\kappa \rangle$ be a sequence of clubs of κ . Then there exists a club E of κ such that $\alpha < \mu \Rightarrow E \subseteq^* E_\alpha$.
- (2) There exists a sequence $\langle E_\alpha : \alpha < \mathfrak{b}_\kappa \rangle$ of clubs of κ such that for no club E of κ we have $\alpha < \mathfrak{b}_\kappa \Rightarrow E \subseteq^* E_\alpha$.
- (3) $\mathfrak{b}_\kappa = \text{add}(\mathbf{NS}_\kappa)$, where \mathbf{NS}_κ is the ideal of non-stationary subsets of κ , ordered by eventual containment \subseteq^* .

Proof. By 5.2.2.

□

Lemma 5.2.4.

- (1) Let $\langle E_\alpha : \alpha < \mu < \mathfrak{d}_\kappa \rangle$ be a sequence of clubs of κ . Then there exists a club E of κ such that for no $\alpha < \mathfrak{d}_\kappa$ we have $E_\alpha \subseteq^* E$.
- (2) There exists a sequence $\langle E_\alpha : \alpha < \mathfrak{d}_\kappa \rangle$ of clubs of κ such that for all clubs E of κ there exists $\alpha < \mathfrak{d}_\kappa$ such that $E_\alpha \subseteq^* E$.
- (3) $\mathfrak{d}_\kappa = \text{cf}(\mathbf{NS}_\kappa)$.

Proof. By 5.2.2. □

Theorem 5.2.5. Let κ be Mahlo (or just S_{pr}^κ stationary, see 1.4.3). Then

$$\mathfrak{b}_\kappa \leq \text{cf}(\mathbf{nst}_\kappa^{\text{pr}}).$$

Proof. Towards contradiction assume $\mu = \text{cf}(\mathbf{nst}_\kappa^{\text{pr}}) < \mathfrak{b}_\kappa$ and let $\langle W_\alpha : \alpha < \mu \rangle$ be a sequence of nowhere stationary subsets of S_{pr}^κ witnessing $\mu = \text{cf}(\mathbf{nst}_\kappa^{\text{pr}})$. For $\alpha < \mu$ let $E_\alpha \subseteq \kappa$ be a club disjoint from W_α . Now we use 5.2.3 to find a club E such that $E \subseteq^* E_\alpha$ for every α . Now because S_{pr}^κ is stationary the closure of $E \cap S_{\text{pr}}^\kappa$ is a club too so without loss of generality $W = \text{nacc}(E) \subseteq S_{\text{pr}}^\kappa$. Clearly W is nowhere stationary so there exists $\alpha < \mu$ such that $W \subseteq^* W_\alpha$.

Now because $E \subseteq^* E_\alpha$ and $W_\alpha \cap E_\alpha = \emptyset$ we have $W_\alpha \cap E$ is bounded. On the other hand because W is an unbounded subset of E and $W \subseteq W_\alpha$ we have $W_\alpha \cap E$ is unbounded. Contradiction. □

Corollary 5.2.6. $\mathfrak{b}_\kappa \leq \text{cf}(\mathbb{Q}_\kappa)$.

Proof. Combine 5.2.5 and 3.3.7 □

Theorem 5.2.7. Let κ be Mahlo (or just S_{pr}^κ stationary). Then

$$\text{add}(\mathbf{nst}_\kappa^{\text{pr}}) \leq \mathfrak{d}_\kappa.$$

Proof. Let $\langle E_\alpha : \alpha < \mu \rangle$ witness $\mathfrak{d}_\kappa = \mu$ in the sense of 5.2.4, i.e. for every club E of κ there is $\alpha < \mu$ such that $E_\alpha \subseteq^* E$. If we restrict ourself to clubs E such that $\text{nacc}(E) \subseteq S_{\text{pr}}^\kappa$ then we may also assume that $W_\alpha = \text{nacc}(E_\alpha) \subseteq S_{\text{pr}}^\kappa$. Towards contradiction assume $\text{add}(\mathbf{nst}_\kappa^{\text{pr}}) > \mu$ and let $W \in \mathbf{nst}_\kappa^{\text{pr}}$ such that $\alpha < \mu \Rightarrow W_\alpha \subseteq^*$

W . Choose a club E disjoint from W such that $\text{nacc}(E) \subseteq S_{\text{pr}}^\kappa$. Now there exists $\alpha < \mu$ such that $E_\alpha \subseteq^* E$ hence

$$\text{sup}(E_\alpha \setminus E) < \delta \in W_\alpha \subseteq E_\alpha \Rightarrow \delta \in E \Rightarrow \delta \notin W_\alpha.$$

Contradiction. □

Corollary 5.2.8. $\text{add}(\mathbb{Q}_\kappa) \leq \mathfrak{d}_\kappa$.

Proof. Combine 5.2.7 and 3.3.7 □

Theorem 5.2.9. *Let κ be inaccessible and let $S \subseteq S_{\text{pr}}^\kappa$ be stationary non-reflecting. Then*

$$(1) \text{add}(\mathbf{nst}_\kappa^{\text{pr}}) \leq \mathfrak{b}_\kappa.$$

$$(2) \text{add}(\mathbf{nst}_{\kappa, S}^{\text{pr}}) = \mathfrak{b}_\kappa.$$

Remark 5.2.10. Note that under these assumptions, by (Shelah 2017, Claim 6.9) the forcing \mathbb{Q}_κ adds a κ -Cohen real.

Proof. First note that because S is not reflecting we have $W \subseteq S$ is nowhere stationary iff W is not stationary.

Recall 5.2.3 and let $\langle E_\alpha : \alpha < \mathfrak{b}_\kappa \rangle$ be set of clubs of κ such that for no club for every club E of κ there exist $\alpha < \mathfrak{b}_\kappa$ such that $\neg(E \subseteq^* E_\alpha)$. So the family $\langle S \setminus E_\alpha : \alpha < \mathfrak{b}_\kappa \rangle$ is a set of nowhere stationary subsets of S_{pr}^κ with no upper bound in $\mathbf{nst}_{\kappa, S}^{\text{pr}}$ (and in particular not in $\mathbf{nst}_\kappa^{\text{pr}}$).

Conversely let $\langle W_\alpha : \alpha < \mu \rangle$ witness $\text{add}(\mathbf{nst}_{\kappa, S}^{\text{pr}}) = \mu$ and let E_α be club disjoint from W_α . Then $\langle E_\alpha : \alpha < \mu \rangle$ is an unbounded family in the sense of 5.2.3. □

Theorem 5.2.11. *Let κ be inaccessible and let $S \subseteq S_{\text{pr}}^\kappa$ be stationary non-reflecting. Then*

$$(1) \mathfrak{d}_\kappa \leq \text{cf}(\mathbf{nst}_\kappa^{\text{pr}}).$$

$$(2) \mathfrak{d}_\kappa = \text{cf}(\mathbf{nst}_{\kappa, S}^{\text{pr}}).$$

Proof. Dual of 5.2.10. □

We summarize the results of this section in the following corollary.

Corollary 5.2.12. *If at least one of the following conditions is satisfied:*

- (1) $\kappa > \text{sup}(S_{\text{inc}}^\kappa)$ or
- (2) *There exists a stationary non-reflecting $S \subseteq S_{\text{pr}}^\kappa$ or*
- (3) $\mathfrak{b}_\kappa > \text{add}(\text{Cohen}_\kappa)$.

Then Bartoszyński-Raisonnier-Stern theorem holds, i.e. we have

$$\text{add}(\mathbb{Q}_\kappa) \leq \text{add}(\text{Cohen}_\kappa).$$

Likewise if we let

$$(3') \ \mathfrak{d}_\kappa < \text{cf}(\text{Cohen}_\kappa).$$

then $(1) \vee (2) \vee (3')$ implies

$$\text{cf}(\text{Cohen}_\kappa) \leq \text{cf}(\mathbb{Q}_\kappa)$$

Finally: if $(1) \vee (2) \vee ((3) \wedge (3'))$, then the Cichoń diagram for $\text{id}(\mathbb{Q}_\kappa)$ and $\text{id}(\text{Cohen}_\kappa)$ looks like the classical diagram. \square

Conjecture 5.2.13. *There exists a model \mathbf{V} such that*

$$\mathbf{V} \models \text{add}(\mathbb{Q}_\kappa) > \text{add}(\text{Cohen}_\kappa)$$

for some sufficiently strong cardinal κ . Note that by 5.1.11 we necessarily have

$$\mathbf{V} \models \mathfrak{b}_\kappa = \text{add}(\text{Cohen}_\kappa)$$

so we really conjecture

$$\text{CON}(\text{add}(\mathbb{Q}_\kappa) > \mathfrak{b}_\kappa).$$

CHAPTER 6

Models

We follow the notation of (Bartoszyński and Judah 1995): Let $\square = \kappa^+$, $\blacksquare = \kappa^{++}$. This will allow us to graphically represent the values of the cardinal characteristics in Figure 5.1. E.g. \square in the top left corner means $\text{cov}(\mathbb{Q}_\kappa) = \square$. Note that in all diagrams of this section we have $2^\kappa = \blacksquare = \kappa^{++}$.

For visual clarity we omit the diagonal arrow from $\text{cov}(\mathbb{Q}_\kappa)$ to $\text{non}(\mathbb{Q}_\kappa)$, see 5.1.8. Note again that the dashed arrows representing $\text{add}(\mathbb{Q}_\kappa) \leq \mathfrak{d}_\kappa$ and $\mathfrak{b}_\kappa \leq \text{cf}(\mathbb{Q}_\kappa)$ need κ is Mahlo (or at least S_{pr}^κ stationary).

If we would like \mathbb{Q}_κ to be κ^κ -bounding, i.e. want κ weakly compact, we may use Laver preparation to preserve supercompactness (so in particular weak compactness) in the forcing extension, see (Laver 1978). Note that all forcing notions in this section, with the exception of Amoeba forcing, are $<\kappa$ -directed closed and Amoeba forcing may be included in the preparation as well by 6.6.4.

6.1 The Cohen Model

Definition 6.1.1. Let

$$\mathbb{C}_\kappa = 2^{<\kappa}$$

and for $p, q \in \mathbb{C}_\kappa$ define q to be stronger than p if $p \leq q$. We call \mathbb{C}_κ the κ -Cohen forcing. If G is a \mathbb{C}_κ -generic filter then we call $\eta = \bigcup_{s \in G} s$ the generic κ -Cohen real (of $\mathbf{V}[G]$). Conversely we say $\nu \in 2^\kappa$ is a κ -Cohen real (over \mathbf{V}) if $G = \{s \in 2^{<\kappa} : s \triangleleft \nu\}$

is a \mathbb{C}_κ -generic filter.

Fact 6.1.2. Let $\nu \in 2^\kappa$. Then ν is a κ -Cohen real over \mathbf{V} iff it is not contained in any meager set of \mathbf{V} . \square

Lemma 6.1.3.

1. \mathbb{C}_κ is $<\kappa$ -directed closed.
2. \mathbb{C}_κ is κ -centered $_{<\kappa}$.
3. \mathbb{C}_κ satisfies $(*)_\kappa$.

Proof. (1.) and (2.) are trivial. Then (3.) easily follows from 2.1.5, 2.3.2, 2.2.9. \square

Definition 6.1.4. Let μ be an ordinal. Let $\mathbb{C}_{\kappa,\mu}$ be the limit of the $<\kappa$ -support iteration $\langle \mathbb{C}_{\kappa,\alpha}, \dot{\mathbb{R}}_\alpha : \alpha < \mu \rangle$ where $\mathbb{C}_{\kappa,\alpha} \Vdash \dot{\mathbb{R}}_\alpha = \dot{\mathbb{C}}_\kappa$ for every $\alpha < \mu$.

It is easy to check that $\prod_{i < \mu} \mathbb{C}_\kappa$ can be canonically embedded as a dense subset into $\mathbb{C}_{\kappa,\mu}$.

Lemma 6.1.5. Let μ be an ordinal. Then $\mathbb{C}_{\kappa,\mu}$ satisfies the stationary κ^+ -Knaster condition and in particular $\mathbb{C}_{\kappa,\mu}$ satisfies the κ^+ -c.c.

Proof. By 6.1.3, 2.2.8, 2.2.3. \square

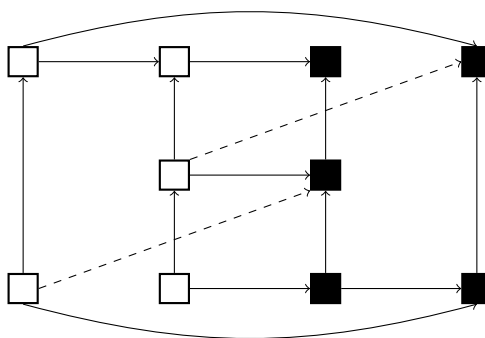

Figure 6.1: Cohen model

Theorem 6.1.6. Let $\mathbf{V} \models 2^\kappa = \kappa^+$. Then $\mathbf{V}^{\mathbb{C}_{\kappa,\kappa^{++}}}$ satisfies:

1. $\text{non}(\text{Cohen}_\kappa) = \kappa^+$.

2. $\text{cov}(\text{Cohen}_\kappa) = \kappa^{++}$.

3. $2^\kappa = \kappa^{++}$.

We call $\mathbf{V}^{\mathbb{C}_{\kappa, \kappa^{++}}}$ the κ -Cohen model.

Proof.

1. This is a standard argument from the classical case but we give details.

Let $\dot{M} = \{\dot{\eta}_\alpha : \alpha < \kappa^+\}$ where $\dot{\eta}_\alpha$ is a name for the κ -Cohen real added by $\dot{\mathbb{R}}_\alpha$. We claim $\mathbb{C}_{\kappa, \kappa^{++}} \Vdash \dot{M}$ is a nonmeager set". Towards contradiction assume that there are $\langle \dot{A}_i : i < \kappa \rangle$ where \dot{A}_i is a $\mathbb{C}_{\kappa, \kappa^{++}}$ -name for a closed, nowhere dense set and there exists $p \in \mathbb{C}_{\kappa, \kappa^{++}}$ such that $p \Vdash \dot{M} \subseteq \bigcup_{i < \kappa} \dot{A}_i$ ". It is easy to see that any closed nowhere dense set $A_i \in \mathbf{V}^{\mathbb{C}_{\kappa, \kappa^{++}}}$ is decided by $|2^{<\kappa}| = \kappa$ -many antichains $\langle \mathcal{J}_{i,s} : s \in 2^{<\kappa} \rangle$ where $\mathcal{J}_{i,s}$ decides the hole of A_i above s , i.e. decides $\dot{t}_{i,s} \supseteq s$ such that $[t_{i,s}] \cap A_i = \emptyset$. Remember 6.1.5 and let

$$\alpha \in \kappa^+ \setminus \left(\bigcup_{i < \kappa} \bigcup_{s \in 2^{<\kappa}} \text{supp}(p_{s,i}) \right).$$

Remember 6.1.4 and let Π be the range of the dense embedding of $\prod_{i < \kappa^{++}} \mathbb{C}_\kappa$ into $\mathbb{C}_{\kappa, \kappa^{++}}$. Without loss of generality $\mathcal{J}_{i,s} \subseteq \Pi$ for all $i < \kappa$ and all $s \in 2^{<\kappa}$ and also $p \in \Pi$. Find $p' \leq p$ such that $p' \in \Pi$ and let $s = p(\alpha)$. Now for arbitrary $i < \kappa$ we can find $r \in \mathcal{J}_{i,s}$, $r \not\leq p'$ and let $p'' = r \wedge p'$. Now because $p', r \in \Pi$ we have $p''(\alpha) = s$ and p'' decides $t_s \supseteq s$ to be missing from A_i . Thus define $p''' \leq p''$ such that $p'''(\alpha) = t_s$ and $p'''(\beta) = p''(\beta)$ for $\beta \in \kappa^{++} \setminus \{\alpha\}$. Clearly $\dot{\eta}_\alpha \supseteq t_s$ thus $p''' \Vdash \dot{\eta}_\alpha \notin \dot{A}_i$ ". Clearly $p''' \leq p$ hence contradicting $p \Vdash \dot{M} \subseteq \bigcup_{i < \kappa} \dot{A}_i$ ".

2. Same argument as in 6.2.7.

3. Should be clear using nice names. □

6.2 The Hechler Model

Definition 6.2.1. Let

$$\mathbb{H}_\kappa = \kappa^{<\kappa} \times [\kappa^\kappa]^{<\kappa}$$

and for $p_1 = (\rho_1, X_1), p_2 = (\rho_2, X_2) \in \mathbb{H}_\kappa$ define p_2 to be stronger than p_1 if:

1. $\rho_2 \supseteq \rho_1$.
2. $X_2 \supseteq X_1$.
3. For all $i \in \text{dom}(\rho_2) \setminus \text{dom}(\rho_1)$ and for all $f \in X_1$ we have $\rho_2(i) > f(i)$.

We call \mathbb{H}_κ the κ -Hechler forcing. If G is a \mathbb{H}_κ -generic filter then we call $\eta = \bigcup_{(\rho, X) \in G} \rho$ the generic κ -Hechler real.

The intended meaning of a condition (ρ, X) is the promise that the κ -Hechler real will start with ρ and from now on (i.e. past the length of ρ) dominate all functions in X .

Fact 6.2.2. Let η a κ -Hechler real over \mathbf{V} . Then for every $\nu \in \kappa^\kappa \cap \mathbf{V}$ we have $\nu \leq^* \eta$. □

Fact 6.2.3. Let η a κ -Hechler real over \mathbf{V} . Let $\nu \in 2^\kappa$ be such that for all $i < \kappa$

$$\nu(i) \equiv \eta(i) \pmod{2}.$$

Then ν is a κ -Cohen real over \mathbf{V} . □

Lemma 6.2.4.

1. \mathbb{H}_κ is $<\kappa$ -directed closed.
2. \mathbb{H}_κ is κ -centered $_{<\kappa}$.
3. \mathbb{H}_κ satisfies $(*)_\kappa$. □

Proof.

1. Let $D \subseteq \mathbb{H}_\kappa$, $|D| < \kappa$, $p, q \in D \Rightarrow p \not\perp q$. If $p = (\rho_1, X_1), q = (\rho_2, X_2) \in D$ then because p, q are compatible we have $\rho_1 \leq \rho_2 \vee \rho_2 \leq \rho_1$. Hence (ρ^*, X^*) is a lower bound for D where $\rho^* = \bigcup_{(\rho, X) \in D} \rho$, $X^* = \bigcup_{(\rho, X) \in D} X$.
2. $\mathbb{H}_\kappa = \bigcup_{\rho \in \kappa^{<\kappa}} (\{\rho\} \times [\kappa^\kappa]^{<\kappa})$.
3. By (1.), (2.), 2.1.5, 2.3.2, 2.2.9. □

Definition 6.2.5. Let μ be an ordinal. Let $\mathbb{H}_{\kappa, \mu}$ be the limit of the $<\kappa$ -support iteration $\langle \mathbb{H}_{\kappa, \alpha}, \dot{\mathbb{R}}_\alpha : \alpha < \mu \rangle$ where $\mathbb{H}_{\kappa, \alpha} \Vdash \dot{\mathbb{R}}_\alpha = \mathbb{H}_\kappa$ for every $\alpha < \mu$.

Lemma 6.2.6. . Let μ be an ordinal. Then:

1. $\mathbb{H}_{\kappa,\mu}$ satisfies the stationary κ^+ -Knaster condition and in particular $\mathbb{H}_{\kappa,\mu}$ satisfies the κ^+ -c.c.
2. If $\mu < (2^\kappa)^+$ then $\mathbb{H}_{\kappa,\mu}$ is κ -centered $_{<\kappa}$.

Proof.

1. By 6.2.4, 2.2.8, 2.2.3.
2. Remember 6.2.4(2.). Easily check that $\mathbb{H}_{\kappa,\mu}$ is finely $<\kappa$ -closed so use 2.3.7. \square

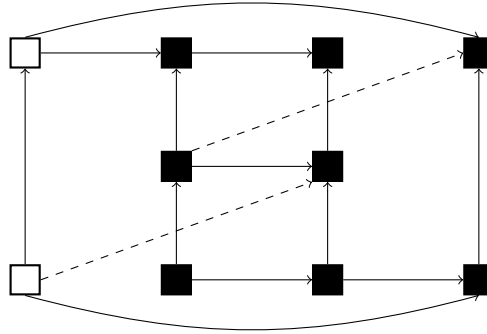

Figure 6.2: Hechler model

Theorem 6.2.7. Let $\mathbf{V} \models 2^\kappa = \kappa^+$. Then $\mathbf{V}^{\mathbb{H}_{\kappa,\kappa^{++}}}$ satisfies:

1. $\text{cov}(\mathbb{Q}_\kappa) = \kappa^+$.
2. $\mathfrak{b}_\kappa = \kappa^{++}$.
3. $\text{cov}(\text{Cohen}_\kappa) = \kappa^{++}$.
4. $\text{add}(\text{Cohen}_\kappa) = \kappa^{++}$.
5. $2^\kappa = \kappa^{++}$.

We call $\mathbf{V}^{\mathbb{H}_{\kappa,\kappa^{++}}}$ the κ -Hechler model.

Proof. We use the iteration theorems from section 2 so the following proofs become standard arguments from the classical case.

1. We claim that $\mathbb{H}_{\kappa, \kappa^{++}}$ does not add \mathbb{Q}_κ -generic reals. Remember 6.2.6(1.) so if we have a nice $\mathbb{H}_{\kappa, \kappa^{++}}$ -name $\dot{\eta}$ for a κ -real the antichains deciding $\dot{\eta}$ are already antichains of $\mathbb{H}_{\kappa, \alpha}$ for some $\alpha < \kappa$. Note that if we show that $\mathbb{H}_{\kappa, \alpha}$ does not add \mathbb{Q}_κ -generic reals for any $\alpha < \kappa^{++}$ we are done:

If $\eta \in \mathbf{V}^{\mathbb{H}_{\kappa, \alpha}}$ is not \mathbb{Q}_κ -generic over \mathbf{V} then there is a Borel code $c \in \mathbf{V}$ of an $\text{id}(\mathbb{Q}_\kappa)$ -set \mathcal{B}_c such that $\eta \in \mathcal{B}_c$. The same is still true in $\mathbf{V}^{\mathbb{H}_{\kappa, \kappa^{++}}}$, see 1.2.7.

By 6.2.6 (2.) $\mathbb{H}_{\kappa, \alpha}$ is a κ -centered $_{<\kappa}$ forcing notion for each $\alpha < \kappa^{++}$ and thus by 2.3.9 does not add a \mathbb{Q}_κ -generic real. In \mathbf{V} there exists a covering of $\text{id}(\mathbb{Q}_\kappa)$ of size κ^+ and because $\mathbb{H}_{\kappa, \kappa^{++}}$ does not add \mathbb{Q}_κ -generic reals this covering remains a covering in $\mathbf{V}^{\mathbb{H}_{\kappa, \kappa^{++}}}$.

2. Assume there exists an unbounded family of size κ^+ in $\mathbf{V}^{\mathbb{H}_{\kappa, \kappa^{++}}}$. Argue as above to see that this family already appears in some $\mathbf{V}^{\mathbb{H}_{\kappa, \alpha}}$. But by 6.2.2 \mathbb{R}_α adds a bound. Contradiction.
3. Assume there exists an covering of $\text{id}(\text{Cohen}_\kappa)$ of size κ^+ in $\mathbf{V}^{\mathbb{H}_{\kappa, \kappa^{++}}}$. Again this family already appears in some $\mathbf{V}^{\mathbb{H}_{\kappa, \alpha}}$. But by 6.2.3 $\dot{\mathbb{R}}_\alpha$ adds a κ -Cohen real hence the covering is destroyed. Contradiction.
4. Remember 5.1.6 so this follows from (2.) and (3.).
5. Should be clear. □

6.3 The Short Hechler Model

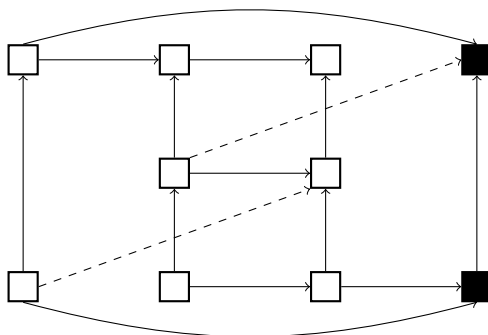

Figure 6.3: Short Hechler model

Theorem 6.3.1. *Let $\mathbf{V} \models \kappa$ is weakly compact. Let $\mathbf{V} \models \text{non}(\mathbb{Q}_\kappa) = \kappa^{++}$ (e.g. $\mathbf{V} = \mathbf{V}_0^{\mathbb{H}_{\kappa, \kappa^{++}}}$).*

Let $\mathbb{H}_{\kappa, \kappa^+}$ be the $<\kappa$ -support iteration of length κ^+ of Hechler reals (see 6.2.5). Then $\mathbf{V}^{\mathbb{H}_{\kappa, \kappa^+}}$ satisfies:

1. $\text{non}(\mathbb{Q}_\kappa) = \kappa^{++}$.
2. $\mathfrak{d}_\kappa = \kappa^+$.
3. $\text{non}(\text{Cohen}_\kappa) = \kappa^+$.
4. $\text{cf}(\text{Cohen}_\kappa) = \kappa^+$.
5. $2^\kappa = \kappa^{++}$.

Proof.

1. Follows by 2.3.7 and 2.3.13.
2. Remember 6.2.2 so $\{\eta_\epsilon : \epsilon < \kappa^+\}$ is a dominating family where η_ϵ is the κ -Hechler real added by \mathbb{R}_ϵ .
3. We claim $\{\nu_\epsilon : \epsilon < \kappa^+\} \not\subseteq \text{id}(\text{Cohen}_\kappa)$ were $\nu_\epsilon \in 2^\kappa$ is the canonical κ -Cohen real added by \mathbb{R}_ϵ (see 6.2.3). Argue as in 6.1.6 but instead of using the product we find α greater than the support of all antichains.
4. Remember 5.1.6 so this follows from (2.) and (3.).
5. Should be clear. □

6.4 Amoeba forcing, part 1

Definition 6.4.1. Let $\mathbb{Q}_\kappa^{\text{am},1}$ be the forcing consisting of tuples (ϵ, S, E) where:

1. $\epsilon \in S_{\text{inc}}^\kappa$.
2. $S \subseteq S_{\text{inc}}^\kappa$ is nowhere stationary.
3. $E \subseteq \kappa$ is a club disjoint from S .

For $p \in \mathbb{Q}_\kappa^{\text{am},1}$ we will write ϵ^p, S^p, E^p for the respective components of p .

For $p = (\epsilon_p, S_p, E_p), q = (\epsilon_q, S_q, E_q)$ we define $q \leq p$ (q stronger than p) iff either $q = p$, or:

1. $\epsilon_p < \epsilon_q$, and moreover the set E_q meets the interval (ϵ_p, ϵ_q) .
2. $S_p \cap \epsilon_p = S_q \cap \epsilon_p$
3. $S_p \setminus \epsilon_p \subseteq S_q \setminus \epsilon_p$.
4. $E_p \cap \epsilon_p = E_q \cap \epsilon_p$.
5. $E_p \supseteq E_q$.

The intended meaning of a condition (ϵ, S, E) is the promise to cover S from now on above ϵ but not tamper with it below ϵ (to preserve the fact that $S \cap \epsilon$ is nowhere stationary in ϵ). The purpose of E is to ensure that the generic set will not be stationary in κ .

Lemma 6.4.2. *Let G be a $\mathbb{Q}_\kappa^{\text{am1}}$ -generic filter and let*

$$S^* = \cup\{S : (\exists p \in G) S = S^p\},$$

$$E^* = \cap\{E : (\exists p \in G) E = E^p\}.$$

Then:

1. E^* is a club of κ disjoint from S^* .
2. S^* is a nowhere stationary subset of κ .
3. For any nowhere stationary set $S \subseteq \kappa$, $S \in \mathbf{V}$ we have $\mathbf{V}^{\mathbb{Q}_\kappa^{\text{am1}}} \models S \subseteq^* S^*$ (i.e., the set $S \setminus S^*$ is bounded).

We call S^ the generic nowhere stationary set.*

Proof.

1. Assume that $(\epsilon, S, E) \Vdash "E^* \subseteq \alpha < \kappa"$. Find $\beta \in E$, $\gamma \in S_{\text{inc}}^\kappa$ with $\alpha < \beta < \gamma$. Then $(\gamma, S, E) \leq (\alpha, S, E)$ and $(\gamma, S, E) \Vdash \beta \in E^*$, contradicting what (ϵ, S, S) forced. So E^* is unbounded.

As an intersection of closed sets, E^* must be closed. E^* is disjoint from S^* by definition.

2. To see $S^* \cap \alpha$ is non-stationary for $\alpha \in S_{\text{inc}}^\kappa$ argue as in (1.). To see S^* is non-stationary in κ , remember that E^* is a club disjoint from S^* by (1.).

3. Let $p = (\epsilon, S, E) \in \mathbb{Q}_\kappa^{\text{am1}}$ and let $S' \in \mathbf{V}$ be nowhere stationary and let E' be a club disjoint from S' . Then $(\epsilon, S \cup (S' \setminus \epsilon), E \cap (E' \cup \epsilon)) \leq p$ forces $S \subseteq S^* \cup \epsilon$, hence also $S \subseteq^* S^*$. As p was arbitrary we are done. \square

Lemma 6.4.3.

1. $\mathbb{Q}_\kappa^{\text{am1}}$ is $<\kappa$ -closed.
2. $\mathbb{Q}_\kappa^{\text{am1}}$ is κ -linked.
3. $\mathbb{Q}_\kappa^{\text{am1}}$ satisfies $(*)_\kappa$.

Proof.

1. Let $\langle p_i : i < \delta \rangle$ be a strictly decreasing sequence, $\delta < \kappa$ a limit ordinal, and let $p_i = (\epsilon_i, S_i, E_i)$. Hence the sequence $\langle \epsilon_i : i < \delta \rangle$ is strictly increasing, so in particular $\epsilon_i \geq i$:

We define a condition $p^* = (\epsilon^*, S^*, E^*)$ as follows:

- (a) $\epsilon^* = \sup_{j < \delta} \epsilon_j$. (So $\epsilon^* \geq \delta$)
- (b) $S^* = \bigcup_{j < \delta} S_j$.
- (c) $E^* = \bigcap_{j < \delta} E_j$.

Clearly E^* is club in κ and disjoint to S^* , so S^* is nonstationary.

For $\delta' < \delta$ the sequence $\langle S_i \cap \delta' : i < \delta \rangle$ is eventually constant with value $S_{\delta'} \cap \delta'$, so $S^* \cap \delta'$ is nonstationary in δ' .

For $\delta' > \delta$ the set $S^* \cap \delta'$ is the union of a small number of nonstationary sets, hence is nonstationary.

We have to check that $S^* \cap \delta$ is nonstationary in δ (if δ is inaccessible).

Case 1 $\epsilon^* = \delta$. Then $E^* \cap (\epsilon_i, \epsilon_{i+1}) = E_{i+1} \cap (\epsilon_i, \epsilon_{i+1})$ is nonempty for all $i < \delta$, so E is unbounded (hence club) in ϵ^* . Hence S is nonstationary in ϵ^* .

Case 2 $\epsilon^* > \delta$. Then we can find $i < \delta$ with $\epsilon_i > \delta$, and we see that $S^* \cap \epsilon_i = S_i \cap \epsilon_i$, so also $S^* \cap \delta = S_i \cap \delta$ is nonstationary.

Finally we show that $p^* \leq p$: The main point is that $(\forall j \geq i) S_j \cap \delta_i = S_i \cap \delta_i$, so also $S^* \cap \delta_i = S_i \cap \delta_i$.

2. Consider $f : \mathbb{Q}_\kappa^{\text{am}1} \rightarrow \kappa \times 2^{<\kappa} \times 2^{<\kappa}$ where $f(\epsilon, S, E) = (\epsilon, S \cap \epsilon, E \cap \epsilon)$. Now check that for $p, q \in \mathbb{Q}_\kappa^{\text{am}1}$ we have $f(p) = f(q) \Rightarrow p \not\leq q$.
3. By (1.), (2.) and 2.2.9.

□

We want to iterate Amoeba forcing (together with the forcing in the next subsection, and possibly other forcings) and not lose the weak compactness of κ . So we will start in a model where κ is supercompact, and this supercompactness is not destroyed by $<\kappa$ -directed closed forcing, and also not by our Amoeba forcings.

As Amoeba forcing is not $<\kappa$ -directed closed, we cannot use Laver's theorem directly. However, it is well known that a slightly weaker property is also sufficient.

The following definition is copied from (König 2006).

Definition 6.4.4. If P is a partial ordering then we always let $\theta = \theta_P$ be the least regular cardinal such that $P \in H_\theta$. Say that a set $X \in \mathfrak{P}_\kappa(H_\theta)$ is P -complete if every (X, P) -generic filter has a lower bound in P .

Define $\mathcal{H}(P) := \{X \in \mathfrak{P}_\kappa(H_\theta) \mid X \text{ is } P\text{-complete}\}$.

Then a partial ordering P is called almost κ -directed-closed if P is strategically κ -closed and $\mathcal{H}(P)$ is in every supercompact ultrafilter on $\mathfrak{P}_\kappa(H_\theta)$.

We will show that for the forcings P we consider, the set $\mathcal{H}(P)$ contains all small elementary submodels of H_θ , is therefore closed unbounded, hence an element of every (fine) normal ultrafilter on $\mathfrak{P}_\kappa(H_\theta)$. (See (Kanamori 1994, chap. 22 and 25.4).)

Definition 6.4.5. Let $G_1 \subseteq \mathbb{Q}_\kappa^{\text{am},1}$. We call a triple (δ_1, S_1, E_1) a *pivot* for G_1 if the following hold (where we write δ_2 for the first inaccessible above δ_1):

- $\delta_1 < \kappa$ (usually a limit ordinal).
- S_1, E_1 are disjoint subsets of δ_1 , E_1 is club in δ_1 , S_1 is nowhere stationary in δ_1 .
- $G_1 \subseteq \mathbb{Q}_\kappa^{\text{am},1}$, $|G_1| < \delta_2$, G_1 is a filter.
- For all $p = (\epsilon, S, E) \in G_1$, (S_1, E_1) is “stronger” than p in the following sense:
 - $\epsilon < \delta_1$.

- $S \cap \epsilon = S_1 \cap \epsilon$, $E \cap \epsilon = E_1 \cap \epsilon$.
- $S \cap \delta_1 \subseteq S_1$.
- $E \cap \delta_1 \supseteq E_1$.

Note: When we say that G_1 has a pivot, it is implied that G_1 is a filter of small cardinality.

Lemma 6.4.6 (Master conditions in $\mathbb{Q}_\kappa^{\text{am},1}$). *Assume that $G_1 \subseteq \mathbb{Q}_\kappa^{\text{am},1}$ has a pivot. Then G_1 has a lower bound in $\mathbb{Q}_\kappa^{\text{am},1}$, i.e., $(\exists p^* \in \mathbb{Q}_\kappa^{\text{am},1}) (\forall p \in G_1) p^* \leq p$.*

Proof. Let (δ_1, S_1, E_1) be a pivot for G_1 .

We let $p^* := (\delta_1, S^*, E^*)$, where

- $S^* \cap \delta_1 := S_1 \cap \delta_1$.
- $E^* \cap \delta_1 := E_1 \cap \delta_1$.
- $S^* \setminus \delta_1 := \bigcup_{(\epsilon, S, E) \in G_1} S \setminus \delta_1$.
- $E^* \setminus \delta_1 := \bigcap_{(\epsilon, S, E) \in G_1} E \setminus \delta_1$.

Note that the ideal of nowhere stationary subsets of $[\delta_1, \kappa)$ is δ_2 -closed, so S^* is indeed nowhere stationary above δ_1 . (Also nowhere stationary below and up to δ_1 , because S_1 had this property.)

Hence p^* is indeed a condition. It is clear that p^* is stronger than all $p \in G_1$. \square

Corollary 6.4.7. *Let $N \prec H_\theta$, $N \in \mathfrak{P}_\kappa(H_\theta)$, $\mathbb{Q}_\kappa^{\text{am},1} \in N$, $N \cap \kappa \in \kappa$.*

Then $N \in \mathcal{H}(\mathbb{Q}_\kappa^{\text{am},1})$ (see Definition 6.4.4).

Proof. Let $G \subseteq \mathbb{Q}_\kappa^{\text{am},1} \cap N$ be $(N, \mathbb{Q}_\kappa^{\text{am},1})$ -generic. Let $\delta_1 := N \cap \kappa$, and let (S_1, E_1) be the generic object determined by G as in 6.4.2. Then (δ_1, S_1, E_1) is a pivot for G , so by 6.4.6 we can find a lower bound for G in $\mathbb{Q}_\kappa^{\text{am},1}$. \square

6.5 Amoeba forcing, part 2

Definition 6.5.1. Let $S \subseteq S_{\text{inc}}^\kappa$. Let $\mathbb{Q}_{\kappa, S}^{\text{am}2}$ to be the forcing consisting of pairs (ϵ, \vec{A}) where:

1. $\epsilon < \kappa$

$$2. \vec{A} = (A_\delta : \delta \in S) \in \prod_{\delta \in S} \text{id}(\mathbb{Q}_\delta).$$

For $p = (\epsilon_p, \vec{A}_p)$, $q = (\epsilon_q, \vec{A}_q)$ we define $q \leq p$ iff either $q = p$ or:

1. $\epsilon_p < \epsilon_q$.
2. $\vec{A}_p \upharpoonright (S \cap \epsilon_p) = \vec{A}_q \upharpoonright (S \cap \epsilon_p)$
3. For all $\delta \in S$ $A_p(\delta) \subseteq A_q(\delta)$.

Lemma 6.5.2. *Let G be a $\mathbb{Q}_{\kappa, S}^{\text{am}2}$ -generic filter, let*

$$\vec{A}^* = (A_\delta^* : \delta \in S) = \bigcup_{(\epsilon, \vec{A}) \in G} \vec{A} \upharpoonright \epsilon \in \prod_{\delta \in S} \text{id}(\mathbb{Q}_\delta)$$

Then:

1. *For all $(B_\delta : \delta \in S)$, where each $B_\delta \subseteq 2^\delta$ is in $\text{id}(\mathbb{Q}_\delta)$, we have $\Vdash (\forall^\infty \delta) B_\delta \subseteq A_\delta^*$.*
2. *For all $B \in \text{id}_0^-(\mathbb{Q}_{\kappa, S})$ we have $B \subseteq \text{set}_0^-(\vec{A}^*)$.*

Proof. 1. Let $p = (\epsilon, \vec{A}) \in \mathbb{Q}_{\kappa, S}^{\text{am}2}$. Find $(\epsilon, \vec{A}') \in \mathbb{Q}_{\kappa, S}^{\text{am}2}$ be such that:

- (a) $\vec{A} \upharpoonright (S \cap \epsilon) = \vec{A}' \upharpoonright (S \cap \epsilon)$.
- (b) For all $\delta \in S$ with $\delta \geq \epsilon$ let $A'_\delta = A_\delta \cup B_\delta$.

Now check that $A \subseteq \text{set}_0^-(\vec{A}') \subseteq \text{set}_0^-(\vec{A}^*)$

Because p was arbitrary we are done.

2. Follows from 1. □

Lemma 6.5.3. *Let $S \subseteq S_{\text{inc}}^\kappa$. Then:*

1. $\mathbb{Q}_\kappa^{\text{am}2}$ is κ -strategically closed.
2. $\mathbb{Q}_\kappa^{\text{am}2}$ is κ -linked.
3. $\mathbb{Q}_\kappa^{\text{am}2}$ satisfies $(*)_\kappa$.

Proof. Similar to 6.4.3. □

Definition 6.5.4. Let $\mathbb{Q}_\kappa^{\text{am}} := \mathbb{Q}_\kappa^{\text{am}1} * \mathbb{Q}_{\kappa, S^*}^{\text{am}2}$ where S^* is the generic object from $\mathbb{Q}_\kappa^{\text{am},1}$ as in 6.4.2.

Discussion 6.5.5. Note that $\mathbb{Q}_\kappa^{\text{am}}$ here is not the same as the amoeba forcing $\mathbb{Q}_\kappa^{\text{am}}$ defined in (Shelah 2017). But as we see in 6.5.6 it is a modularized variant.

Lemma 6.5.6. *There exists $A^* \in \text{id}^-(\mathbb{Q}) \cap \mathbf{V}^{\mathbb{Q}_\kappa^{\text{am}}}$ such that:*

1. For every $A \in \mathbf{V} \cap \text{id}^-(\mathbb{Q}_\kappa)$ we have $A \subseteq A^*$.
2. If κ is weakly compact then for every $A \in \mathbf{V} \cap \text{id}(\mathbb{Q}_\kappa)$ we have $A \subseteq A^*$.

Proof.

1. Combine 6.4.2 and 6.5.2 and check that $A^* = \text{set}_0^-(\langle A_\delta^* : \delta \in S^* \rangle)$ is as required.
2. By (1.) and 3.2.5. □

The generic null set added by Amoeba forcing will cover all ground model sets in id^- . If κ is weakly compact, then we also cover all id sets. So we are interested in keeping κ weakly compact after our Amoeba iteration.

Definition 6.5.7. Let $S \subseteq S_{\text{inc}}^\kappa$ be nowhere stationary, and let $G_1 \subseteq \mathbb{Q}_{\kappa, S}^{\text{am},2}$.

We call a pair (δ_1, \vec{A}_1) a *pivot* for G_1 if the following hold

- $\delta_1 \in S_{\text{inc}}^\kappa \setminus S$.
- $\vec{A}_1 = (A_{1,\delta} : \delta \in S \cap \delta_1) \in \prod_{\delta \in S \cap \delta_1} \text{id}(\mathbb{Q}_\delta)$
- $G_1 \subseteq \mathbb{Q}_{\kappa, S}^{\text{am},2}$, $|G_1| < \delta_2$, G_1 is a filter (where again δ_2 is the smallest inaccessible $> \delta_1$).
- For all $p := (\epsilon, \vec{B}) \in G_1$:
 - $\epsilon < \delta_1$, and (δ_1, \vec{A}_1) is “stronger” than p in the sense that:
 - $(\forall \delta < \delta_1) B_\delta \subseteq A_{1,\delta}$.
 - $(\forall \delta < \epsilon) B_\delta = A_{1,\delta}$.

Lemma 6.5.8 (Master conditions in $\mathbb{Q}_{\kappa, S}^{\text{am},2}$). *Assume that S is nowhere stationary, and $G_1 \subseteq \mathbb{Q}_{\kappa, S}^{\text{am},2}$ has a pivot. Then the set G_1 has a lower bound in $\mathbb{Q}_{\kappa, S}^{\text{am},2}$, i.e., $(\exists p^* \in \mathbb{Q}_{\kappa, S}^{\text{am},2}) (\forall p \in G_1) p^* \leq p$.*

Proof. Similar to the proof of Lemma 6.4.6.

Let (δ_1, \vec{A}_1) be a pivot. We define a condition $p^* = (\delta_1, \vec{A}^*)$ as follows:

- $(\forall \delta \in S \cap \delta_1) A_\delta^* := A_{1,\delta}$.
- $(\forall \delta \in S \setminus \delta_1) A_\delta^* := \bigcup_{(\epsilon, \vec{A}) \in G_1} A_\delta$.

Why is p condition? Because for all $\delta \in \kappa \setminus \delta_1$, the ideal $\text{id}(\mathbb{Q}_\delta)$ is δ_1 -complete, so the set $\bigcup_{(\epsilon, \nu) \in G_1} \nu(\delta)$ is in the ideal.

It is clear that $p^* \leq p$ for all $p \in G_1$. □

Corollary 6.5.9. *Let $N \prec H_\theta$, $N \in \mathfrak{P}_\kappa(H_\theta)$, $\mathbb{Q} \in N$, $N \cap \kappa \in \kappa$.*

Then $N \in \mathcal{H}(\mathbb{Q})$ (see Definition 6.4.4). □

6.6 Iterated Amoeba Forcing

Notation 6.6.1. For every forcing notion \mathbb{P} we write $\Gamma_{\mathbb{P}}$ for the canonical name of the generic filter on \mathbb{P} .

Definition 6.6.2.

1. Let μ be an ordinal and let \mathbb{P} be the limit of a $<\kappa$ -support iteration $\vec{\mathbb{P}} = \langle \mathbb{P}_\alpha, \dot{\mathbb{R}}_\alpha : \alpha < \mu \rangle$.

We call the iteration $\vec{\mathbb{P}}$ and its limit \mathbb{P} *relevant*, if the following hold: For every $\alpha < \mu$ we have either

- (a) $\mathbb{P}_\alpha \Vdash \dot{\mathbb{R}}_\alpha = \mathbb{Q}_\kappa^{\text{am},1}$ or
- (b) $\mathbb{P}_\alpha \Vdash \dot{\mathbb{R}}_\alpha = \mathbb{Q}_{\kappa,S}^{\text{am},2}$ for some nowhere stationary $S \subseteq S_{\text{inc}}^\kappa$ or
- (c) $\mathbb{P}_\alpha \Vdash \dot{\mathbb{R}}_\alpha$ is $<\kappa$ -directed closed.

(In particular, any $<\kappa$ -directed closed forcing is an example of a relevant iteration.)

2. Let $G_0 \subseteq \mathbb{P}$ be a filter. For $\alpha < \mu$ we will write $G_0 \upharpoonright \alpha$ for the set $\{p \upharpoonright \alpha : p \in G_0\}$, and $G_0(\alpha)$ will be a \mathbb{P}_α -name for the set $\{p(\alpha) : p \in G_0\}$.

We remark that $G_0 \upharpoonright (\alpha + 1)$ is a subset of $\mathbb{P}_\alpha * \mathbb{R}_\alpha$, so the empty condition of \mathbb{P}_α forces “If $G_0 \upharpoonright \alpha \subseteq \Gamma_{\mathbb{P}_\alpha}$, then $G_0(\alpha) \subseteq \mathbb{R}_\alpha$.”

3. Let $G_0 \subseteq \mathbb{P}$ be a filter. A sequence $\langle \eta_\alpha : \alpha < \mu \rangle$ (where each η_α is a \mathbb{P}_α -name) is called a *pivot* for G_0 if for all $\alpha < \mu$ the following statement is forced:

If $G_0 \upharpoonright \mathbb{P}_\alpha \subseteq \Gamma_{\mathbb{P}_\alpha}$, then:

- \mathbb{R}_α is $<\kappa$ -directed closed, $\eta(\alpha) = 0$.
- or: $\eta(\alpha)$ is a pivot (in the sense of Definitions 6.4.5 or 6.5.7, respectively) for $G_0(\alpha) \subseteq \mathbb{R}_\alpha$.

Lemma 6.6.3 (Existence of master conditions in iterations). *Assume that \mathbb{P} is the limit of a relevant iteration. Let $G_0 \subseteq \mathbb{P}$ be a filter, and assume that there is a pivot for G_0 .*

Then there exist $p^ \in \mathbb{P}$ such that*

$$(\forall p \in G_0) p^* \leq p.$$

Proof. We will define p^* by induction, in each coordinate appealing to Lemma 6.4.6 or 6.5.8, as appropriate. (Note that fewer than κ coordinates appear in the conditions in G_0 , so the resulting condition will have support of size $< \kappa$.) \square

Corollary 6.6.4. *Let $N \prec H_\theta$, $N \in \mathfrak{P}_\kappa(H_\theta)$, $N \cap \kappa \in \kappa$. Let $P \in N$ be a relevant iteration.*

Then $N \in \mathcal{H}(P)$ (see Definition 6.4.4).

Hence by (König 2006, Theorem 9): If κ is supercompact, then after forcing with a modified Laver preparation we obtain a model in which κ is not only supercompact, but moreover this supercompactness cannot be destroyed by almost κ -directed closed forcing, so in particular not by relevant iterations. \square

Definition 6.6.5. Let μ be an ordinal. Let $\mathbb{A}_{\kappa,\mu}$ be the limit of the $<\kappa$ -support iteration $\langle \mathbb{A}_{\kappa,\alpha}, \dot{\mathbb{R}}_\alpha : \alpha < \mu \rangle$ where for every $\alpha < \mu$ we have:

$$\mathbb{A}_{\kappa,\alpha} \Vdash \dot{\mathbb{R}}_\alpha = \begin{cases} \mathbb{Q}_\kappa^{\text{am}} & \alpha \text{ even} \\ \mathbb{H}_\kappa & \alpha \text{ odd.} \end{cases}$$

Fact 6.6.6. $\mathbb{A}_{\kappa,\mu}$ is an iteration satisfying the requirements of 6.6.3. \square

Lemma 6.6.7. *Let μ be an ordinal. Then $\mathbb{A}_{\kappa,\mu}$ satisfies the stationary κ^+ -Knaster condition and in particular $\mathbb{A}_{\kappa,\mu}$ satisfies the κ^+ -c.c.*

Proof. By 6.4.3, 6.5.3, 2.2.8, 2.2.3. \square

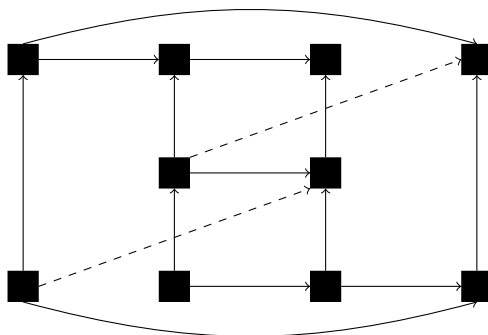

Figure 6.4: Amoeba model

Theorem 6.6.8. *Let $\mathbf{V} \models 2^\kappa = \kappa^+$ and let κ be supercompact, indestructible in the sense of 6.4.4. Then $\mathbf{V}^{\mathbb{A}_{\kappa, \kappa^{++}}}$ satisfies:*

1. $2^\kappa = \kappa^{++}$
2. $\text{add}(\mathbb{Q}_\kappa) = \kappa^{++}$
3. $\text{add}(\text{Cohen}_\kappa) = \kappa^{++}$.

Proof.

1. Should be clear.
2. By (1.) it suffices to show $\text{add}(\mathbb{Q}_\kappa) \geq \kappa^{++}$. So towards contradiction assume $\text{add}(\mathbb{Q}_\kappa) = \kappa^+$ and let $\langle B_i : i < \kappa^+ \rangle$ witness it. Remember $\mathbb{A}_{\kappa, \kappa^{++}}$ satisfies the κ^+ -c.c. by 6.6.7. So there exists $\alpha < \kappa^{++}$ such that $B_i \in \mathbf{V}^{\mathbb{P}^\alpha}$ for every $i < \kappa^+$. But by 6.5.6 there exists $A \in V^{\mathbb{P}^{\alpha+2}} \cap \text{id}(\mathbb{Q}_\kappa)$ such that $B_i \subseteq A$ for every $i < \kappa^+$. By 4.2.2 also $\mathbf{V}^{\mathbb{A}_{\kappa, \kappa^{++}}} \models A \in \text{id}(\mathbb{Q}_\kappa)$. Contradiction.
3. Argue as in 6.2.7. □

6.7 The Short Amoeba Model

Theorem 6.7.1. *Let $\mathbf{V} \models 2^\kappa = \kappa^+$ and let κ be supercompact, indestructible in the sense of 6.4.4. Let $\mu = \kappa^{++} \cdot \kappa^+$. Then $\mathbf{V}^{\mathbb{A}_{\kappa, \mu}}$ satisfies:*

1. $2^\kappa = \kappa^{++}$

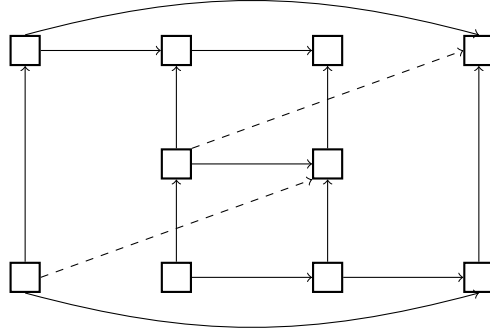

Figure 6.5: Short Amoeba model

2. $\text{cf}(\mathbb{Q}_\kappa) = \kappa^+$.
3. $\mathfrak{d}_\kappa = \kappa^+$.
4. $\text{cf}(\text{Cohen}_\kappa) = \kappa^+$.

Proof.

1. Should be clear.
2. Let $\langle \mu_i : i < \kappa^+ \rangle$ be a cofinal sequence in μ such that for each $i < \kappa^+$ we have μ_i is even. Let A_i be the null set added by $\dot{\mathbb{R}}_{\mu_i}$. Easily by 6.5.6 the sequence $\langle A_i : i < \kappa^+ \rangle$ is cofinal in $\text{id}(\mathbb{Q}_\kappa)$.
3. Let η_i be the Hechler real added by $\dot{\mathbb{R}}_{\mu_{i+1}}$. Easily by 6.2.2 the sequence $\langle \eta_i : i < \kappa^+ \rangle$ is dominating.
4. Assume $\text{cf}(\text{Cohen}_\kappa) > \kappa^+$. Then by (3.) and 5.1.12 and (2.) $\text{cf}(\text{Cohen}_\kappa) \leq \text{non}(\mathbb{Q}_\kappa) \leq \text{cf}(\mathbb{Q}_\kappa) = \kappa^+$. Contradiction. \square

6.8 Cohen-Amoeba Forcing

Definition 6.8.1. Let $\mathbb{C}_\kappa^{\text{am}}$ be the set of all pairs (α, A) such that:

1. $\alpha < \kappa$.
2. $A \subseteq 2^{<\kappa}$ is a tree.
3. $[A] \subseteq 2^\kappa$ is non-empty nowhere dense.

For $p = (\alpha_p, A_p)$, $q = (\alpha_q, A_q)$, $p, q \in \mathbb{C}_\kappa^{\text{am}}$ we define q stronger than p if:

1. $\alpha_q \geq \alpha_p$.
2. $A_q \supseteq A_p$.
3. $A_q \upharpoonright \alpha_p = A_p \upharpoonright \alpha_p$.

We call $\mathbb{C}_\kappa^{\text{am}}$ the Cohen-Amoeba forcing.

Note that $\mathbb{C}_\kappa^{\text{am}}$ is a straightforward generalization of the universal meager forcing defined in (Bartoszyński and Judah 1995, 3.1.9).

Lemma 6.8.2. *Let $\langle A_i : i < i^* < \kappa \rangle$ be a family of nowhere dense subsets of 2^κ . Then $A = \bigcup_{i < i^*} A_i$ is nowhere dense.*

Proof. For $i < i^*$, $s \in 2^{<\kappa}$ let $t(i, s) \in 2^{<\kappa}$ be such that

1. $s \leq t(i, s)$.
2. $A_i \cap [t(i, s)] = \emptyset$.

Let $s \in A$ and we define an increasing sequence $\langle \eta_i : i < i^* \rangle$ as such that:

1. $\eta_0 = s$.
2. $i = j + 1 \Rightarrow \eta_i = t(j, \eta_j)$.
3. If i is a limit ordinal then $\eta_i = \bigcup_{j < i} \eta_j$.

Let $\eta = \bigcup_{i < i^*} \eta_i$ and check:

1. $s \leq \eta$.
2. $A \cap [\eta] = \emptyset$.

Because s was arbitrary we are done. □

Lemma 6.8.3.

1. $\mathbb{C}_\kappa^{\text{am}}$ is $<\kappa$ -directed closed.
2. $\mathbb{C}_\kappa^{\text{am}}$ is κ -linked.
3. $\mathbb{C}_\kappa^{\text{am}}$ satisfies $(*)_\kappa$.

Proof.

1. Easy using 6.8.2.
2. Should be clear.
3. By (1), (2), and 2.2.9. □

Lemma 6.8.4. *Let G be generic for $\mathbb{C}_\kappa^{\text{am}}$ and let $N = \bigcup_{(\alpha, A) \in G} A$. Then for the set*

$$M = \{\eta \in 2^\kappa : (\exists \nu \in N) \nu =^* \eta\}$$

we have:

1. M is meager.
2. M covers every meager set $X \in \mathbf{V}$.
More precisely: for every family $(X_i : i < \kappa) \in \mathbf{V}$ of nowhere dense trees it is forced that $(\forall i < \kappa) [X_i] \subseteq M$ holds.

Proof.

1. It suffices to show that M is nowhere dense. We check that for each $s \in 2^{<\kappa}$ the set

$$D_s = \{q \in \mathbb{C}_\kappa^{\text{am}} : (\exists t \supseteq s) q \Vdash "N \cap [t] = \emptyset"\}$$

is dense in $\mathbb{C}_\kappa^{\text{am}}$. Indeed for any $(\alpha, A) \in \mathbb{C}_\kappa^{\text{am}}$ there exists $t \supseteq s$ such that $A \cap [t] = \emptyset$. Now easily $(\max(\alpha, |t|), A) \in D_s$.

2. Let $X \subseteq 2^{<\kappa}$ such that $[X]$ is nowhere dense and let $(\alpha, A) \in \mathbb{C}_\kappa^{\text{am}}$. Without loss of generality we may assume $|X \cap 2^\alpha| = 1$ (otherwise we just split up X). Now find $\rho \in A \cap 2^\alpha$ and let

$$X' = \{\eta \in 2^\kappa : (\exists \nu \in X) \eta =^* \nu, \eta \upharpoonright \alpha = \rho\}.$$

Easily $q = (\alpha, A \cup X') \in \mathbb{C}_\kappa^{\text{am}}$ and q forces X to be covered by M . □

Theorem 6.8.5. *Let $\mathbf{V} \models 2^\kappa = \kappa^+$. Let $\mathbb{P} = \{\mathbb{P}_i, \dot{\mathbb{R}}_i : i < \mu\}$ be the limit of a $<\kappa$ -support iteration such that that $\mathbb{P}_i \Vdash "\dot{\mathbb{R}}_i = \mathbb{C}_\kappa^{\text{am}}"$ for each $i < \mu$. Then $\mathbf{V}^{\mathbb{P}}$ satisfies:*

1. If $\mu = \kappa^{++}$ then $\text{add}(\text{Cohen}_\kappa) = \kappa^{++}$.

2. If $\text{cf}(\mu) = \kappa^+$ then $\text{cf}(\text{Cohen}_\kappa) = \kappa^+$.

Proof.

1. Use 6.8.4 and argue as in 6.6.8(2.).

2. Use 6.8.4 and argue as in 6.7.1(2.). □

Corollary 6.8.6. *We could use $\mathbb{C}_\kappa^{\text{am}}$ instead of \mathbb{H}_κ for odd iterants in the definition of $\mathbb{A}_{\kappa,\mu}$ in 6.6.5 to achieve the same results in 6.6.8 and 6.7.1 in regard to the characteristics of the diagram.*

6.9 Bounded Perfect Tree Forcing

We give a κ -support alternative to the short Hechler model.

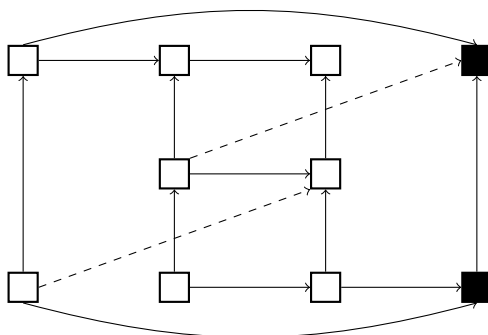

Figure 6.6: Bounded perfect tree model

Definition 6.9.1. Let:

1. $S \subseteq \kappa \cap S_{\text{inc}}$, $\text{sup}(S) = \kappa$, $\partial \in S \Rightarrow \partial > \text{sup}(\partial \cap S_{\text{inc}})$
2. $\langle \partial_\epsilon : \epsilon < \kappa \rangle$ enumerates S in increasing order.
3. $\theta_\epsilon = 2^{\partial_\epsilon}$ for $\epsilon < \kappa$.
4. $T = \bigcup_{\zeta < \kappa} T_\zeta$ where $T_\zeta = \prod_{\epsilon < \zeta} \theta_\epsilon$.

We define \mathbb{T}_κ^S to be the set of all $p \subseteq T$ such that:

- (a) For all $\eta \in p$ we have $\nu \trianglelefteq \eta \Rightarrow \nu \in p$.

(b) There exists a club $E \subseteq \kappa$ such that for all $\eta \in p$:

$$\text{suc}_p(\eta) = \{i < \theta_{\text{lg}(\eta)} : \eta \hat{\ } i \in p\} = \begin{cases} \theta_{\text{lg}(\eta)} & \text{if } \text{lg}(\eta) \in E \\ \{p \hat{\ } i^*\} & \text{if } \text{lg}(\eta) \notin E, \text{ for some } i^* < \theta_{\text{lg}(\eta)} \end{cases}$$

(c) No branches die out in p . I.e. If ζ is a limit ordinal and $\eta \in T_\zeta$ then:

$$\eta \in p \Leftrightarrow (\forall \epsilon < \zeta) \eta \upharpoonright \epsilon \in p.$$

So \mathbb{T}_κ^S is the forcing of all subtrees of T that split fully on a club $E \subseteq \kappa$ of levels and otherwise do not split. The order is defined the usual way, i.e. for $p, q \in \mathbb{T}_\kappa^S$ we have q stronger than p iff $q \subseteq p$. Because for our purposes every S works we will simply write \mathbb{T}_κ instead of \mathbb{T}_κ^S .

Definition 6.9.2. Let $\mathbb{T}_{\kappa, \mu}$ be the limit of the κ -support iteration $\langle \mathbb{T}_{\kappa, \alpha}, \dot{\mathbb{R}}_\alpha : \alpha < \mu \rangle$ where $\mathbb{T}_{\kappa, \alpha} \Vdash \dot{\mathbb{R}}_\alpha = \mathbb{T}_\kappa$ for every $\alpha < \mu$.

Lemma 6.9.3.

1. \mathbb{T}_κ is $<\kappa$ -directed closed.
2. $\mathbb{T}_{\kappa, \kappa^{++}}$ is $<\kappa$ -directed closed.

Proof.

1. Let D be a directed subset of \mathbb{T}_κ of size $< \kappa$. Intersecting the club sets associated with each $p \in D$ will give us a club set E . Letting q be the intersection of all $p \in D$, we claim that q is a condition. It is then clear that q is a lower bound for D .

Clearly q is nonempty and satisfies condition 6.9.1 (a), (c). It remains to verify (b). Let $\eta \in q$.

Case 1: $\text{lg}(\eta) \in E$. So $\text{lg}(\eta) \in E_p$ for all $p \in D$, hence $\text{suc}_q(\eta) = \bigcap_{p \in D} \text{suc}_p(\eta) = \theta_{\text{lg}(\eta)}$.

Case 2: $\text{lg}(\eta) \notin E$. So there is some $p^* \in D$ and some i^* such that $\text{suc}_{p^*}(\eta) = \{i^*\}$. As D is directed, and $\eta \in p$ for all $p \in D$, we also have $\eta \hat{\ } i^* \in p$ for all $p \in D$. Hence $\text{suc}_q(\eta) = \bigcap_{p \in D} \text{suc}_p(\eta) = \{i^*\}$, as required.

2. By 2.1.6. □

Definition 6.9.4. Let $\alpha < \kappa$, $p, q \in \mathbb{T}_\kappa$ and let $\langle e_i : i < \kappa \rangle$ be an enumeration of the club of splitting levels of p . We define

$$q \leq_\alpha p \quad \text{iff} \quad q \leq p \wedge q \cap 2^{\leq e_\alpha} = p \cap 2^{\leq e_\alpha}.$$

Lemma 6.9.5. Let $\vec{p} = \langle p_i : i < \kappa \rangle$ be a sequence of conditions in \mathbb{T}_κ such that $i < j < \kappa \Rightarrow p_j \leq_i p_i$. Then \vec{p} has a lower bound $q \in \mathbb{T}_\kappa$.

Proof. It is easy to check that $q = \bigcap_{i < \kappa} p_i$ is a condition in \mathbb{T}_κ and a lower bound for \vec{p} . □

Definition 6.9.6. We refer to sequences as in 6.9.5 as *fusion sequences*.

Lemma 6.9.7.

- (a) White has a winning strategy for $\mathfrak{F}_\kappa^*(\mathbb{T}_\kappa, p)$ for every $p \in \mathbb{T}_\kappa$.
- (b) White has winning strategy for $\mathfrak{F}_\kappa(\mathbb{T}_{\kappa, \kappa^{++}}, p)$ for every $p \in \mathbb{T}_{\kappa, \kappa^{++}}$.

Proof.

- (a) We are going to construct a fusion sequence $\langle p_\zeta : \zeta < \kappa \rangle$ and a winning strategy for White such that
 - (1) $p_0 = p$.
 - (2) In the ζ -round White plays $\mu_\zeta = |p_\zeta \cap T_\beta|$ and $p_{\zeta, i} = p^{[\eta_{\zeta, i}]}$ where $\langle \eta_{\zeta, i} : i < \mu_\zeta \rangle$ enumerates $p_\zeta \cap T_\beta$ and β is the ζ -th splitting level of p_ζ .
 - (3) $p_{\zeta+1} = \bigcup_{i < \mu_\zeta} p'_{\zeta, i}$ where $p'_{\zeta, i}$ are the moves played by Black.
 - (4) For δ a limit ordinal $p_\delta = \bigcap_{\zeta < \delta} p_\zeta$.

Now use 6.9.5 and check that $q = \bigcap_{\zeta < \kappa} p_\zeta$ witnesses that White wins.

- (b) By 2.4.8. □

Lemma 6.9.8.

- (a) $\mathbb{T}_{\kappa, \kappa^{++}}$ does not collapse κ^+
- (b) Let N be a κ -meager set in $\mathbf{V}^{\mathbb{T}_{\kappa, \kappa^{++}}}$. Then there exists a κ -meager set $M \in \mathbf{V}$ such that $N \subseteq M$.

(c) In particular: If $\mathbf{V} \models 2^\kappa = \kappa^+$ then $\mathbf{V}^{\mathbb{T}_{\kappa, \kappa^{++}}} \models \text{cov}(\text{Cohen}_\kappa) = \kappa^+$.

Proof. By 6.9.7, 2.4.7. □

Lemma 6.9.9. *If $\mathbf{V} \models 2^\kappa = \kappa^+$ then:*

(a) \mathbb{T}_κ satisfies the κ^{++} -c.c.

(b) $\mathbb{T}_{\kappa, \kappa^{++}}$ satisfies the κ^{++} -c.c.

Proof.

(a) By our assumption: $|\mathbb{T}_\kappa| = \kappa^+$.

(b) By 6.9.7, 2.5.9. □

Lemma 6.9.10.

(a) $\mathbb{T}_\kappa \Vdash (2^\kappa)^V \in \text{id}^-(\mathbb{Q}_\kappa)$.

(b) $\mathbf{V}^{\mathbb{T}_{\kappa, \kappa^{++}}} \models \text{non}(\text{id}^-(\mathbb{Q}_\kappa)) \geq \kappa^{++}$.

(c) $\mathbf{V}^{\mathbb{T}_{\kappa, \kappa^{++}}} \models \text{non}(\text{id}(\mathbb{Q}_\kappa)) \geq \kappa^{++}$.

Proof.

(a) Let $\langle A_{\epsilon, i} : i < \theta_\epsilon \rangle$ be a covering sequence in $\text{id}(\mathbb{Q}_{\partial_\epsilon})$. Let $\dot{\nu}$ be a name for the generic κ -real added by \mathbb{T}_κ and define $\vec{\Lambda} = \langle \Lambda_\partial : \partial \in S \rangle$ such that $\text{set}_0(\Lambda_{\partial_\epsilon}) = A_{\epsilon, \dot{\nu}(\epsilon)}$. Now Λ witnesses $(2^\kappa)^V \in \text{id}^-(\mathbb{Q}_\kappa)$ in $\mathbf{V}^{\mathbb{T}_\kappa}$.

(b) Remember that by 6.9.9 all Borel sets appear in $\mathbf{V}^{\mathbb{T}_{\kappa, \alpha}}$ for some $\alpha < \kappa^{++}$. So (b) follows from (a), remembering 6.9.3, 2.1.5, 4.2.2.

(c) Remember $\text{id}^-(\mathbb{Q}_\kappa) \subseteq \text{id}(\mathbb{Q}_\kappa)$ hence $\text{non}(\text{id}^-(\mathbb{Q}_\kappa)) \leq \text{non}(\text{id}(\mathbb{Q}_\kappa))$. So this follows from (b). □

Discussion 6.9.11. The coverings in 6.9.10 could be just be sequences of singletons. So we could say that the lemma speaks on some ideal id^{--} that is defined similar to id^- just with singletons (or maybe sets of size at most κ) instead of $\text{id}(\mathbb{Q}_\delta)$ -sets on each level. So we really show $\text{non}(\text{id}^{--}(\mathbb{Q}_\kappa)) \geq \kappa^{++}$.

Theorem 6.9.12. *If $\mathbf{V} \models 2^\kappa = \kappa^+$ then $\mathbf{V}^{\mathbb{T}_{\kappa, \kappa^{++}}} \models 2^\kappa = \kappa^{++}$.* □

CHAPTER 7

Slaloms

It is well known that slaloms can be used to characterize the additivity and cofinality of measure in the classical case, see for example (Bartoszyński and Judah 1995). In (Brendle, Brooke-Taylor, Friedman, and Montoya 2018) this result motivates a definition: The cardinals $\text{add}(\text{null})$ and $\text{cof}(\text{null})$ are replaced by the appropriate additivity and covering numbers for slaloms.

This raises the question how the characteristics introduced there related to the characteristics of $\text{id}(\mathbb{Q}_\kappa)$ discussed here. In particular one might wonder if the generalized characterization of the additivity of null by slaloms is equal to the additivity of $\text{id}(\mathbb{Q}_\kappa)$. It turns out that for partial slaloms the answer is negative. We conjecture that for total slaloms the answer is negative too, see 7.2.4 and 7.3.1 respectively.

7.1 Recapitulation

Let us start with some results and definitions from (Brendle, Brooke-Taylor, Friedman, and Montoya 2018) (for more details and proofs see there). Since there also successor cardinals κ are considered, let us remind the reader of that in this paper the cardinal κ is always (at least) inaccessible.

Definition 7.1.1. Let $h \in \kappa^\kappa$ be an unbounded function. We define

$$\mathcal{C}_h = \{\phi \in ([\kappa]^{<\kappa})^\kappa : (\forall i < \kappa) \phi(i) \in [\kappa]^{|h(i)|}\}.$$

For $\phi \in \mathcal{C}_h$, $f \in \kappa^\kappa$ we define

$$f \in^* \phi \iff (\forall^\infty i < \kappa) f(i) \in \phi(i).$$

Finally let:

1. $\text{add}(h\text{-slalom}) = \min\{|\mathcal{F}| : \mathcal{F} \subseteq \kappa^\kappa, (\forall \phi \in \mathcal{C}_h)(\exists f \in \mathcal{F}) f \notin^* \phi\}$.
2. $\text{cf}(h\text{-slalom}) = \min\{|\Phi| : \Phi \subseteq \mathcal{C}_h, (\forall f \in \kappa^\kappa)(\exists \phi \in \Phi) f \in^* \phi\}$.

Definition 7.1.2. We may also consider partial slaloms. Let $h \in \kappa^\kappa$ be unbounded and define

$$\text{p}\mathcal{C}_h = \{\phi : (\exists \psi \in \mathcal{C}_h) \phi \subseteq \psi, |\text{dom}(\phi)| = \kappa\}.$$

Again for $\phi \in \text{p}\mathcal{C}_h$, $f \in \kappa^\kappa$ we define

$$f \text{p}\in^* \phi \iff (\forall^\infty i \in \text{dom}(\phi)) f(i) \in \phi(i).$$

Finally let:

1. $\text{add}^{\text{partial}}(h\text{-slalom}) = \min\{|\mathcal{F}| : \mathcal{F} \subseteq \kappa^\kappa, (\forall \phi \in \text{p}\mathcal{C}_h)(\exists f \in \mathcal{F}) f \text{p}\notin^* \phi\}$.
2. $\text{cf}^{\text{partial}}(h\text{-slalom}) = \min\{|\Phi| : \Phi \subseteq \text{p}\mathcal{C}_h, (\forall f \in \kappa^\kappa)(\exists \phi \in \Phi) f \text{p}\in^* \phi\}$.

Discussion 7.1.3. Note that in (Brendle, Brooke-Taylor, Friedman, and Montoya 2018) the notation $\text{add}(h\text{-slalom}) = \mathfrak{b}_h(\in^*)$, $\text{cf}(h\text{-slalom}) = \mathfrak{d}_h(\in^*)$ and similarly $\text{add}^{\text{partial}}(h\text{-slalom}) = \mathfrak{b}_h(\text{p}\in^*)$, $\text{cf}^{\text{partial}}(h\text{-slalom}) = \mathfrak{d}_h(\text{p}\in^*)$ is used.

Lemma 7.1.4. *Let $h \in \kappa^\kappa$ be unbounded. Then:*

- $\text{add}(h\text{-slalom}) \leq \text{add}^{\text{partial}}(h\text{-slalom}) \leq \text{add}(\text{Cohen}_\kappa)$.
- $\text{cf}(h\text{-slalom}) \geq \text{cf}^{\text{partial}}(h\text{-slalom}) \geq \text{cf}(\text{Cohen}_\kappa)$. □

Lemma 7.1.5. *Let $h, g \in \kappa^\kappa$ be unbounded. Then:*

- $\text{add}^{\text{partial}}(h\text{-slalom}) = \text{add}^{\text{partial}}(g\text{-slalom})$.
- $\text{cf}^{\text{partial}}(-\text{slalom}) = \text{cf}^{\text{partial}}(g\text{-slalom})$. □

Discussion 7.1.6. So for partial slaloms we may ignore h and write $\text{add}^{\text{partial}}(\kappa)$ instead of $\text{add}^{\text{partial}}(h\text{-slalom})$ and similarly $\text{cf}^{\text{partial}}(\kappa)$ instead of $\text{cf}^{\text{partial}}(h\text{-slalom})$.

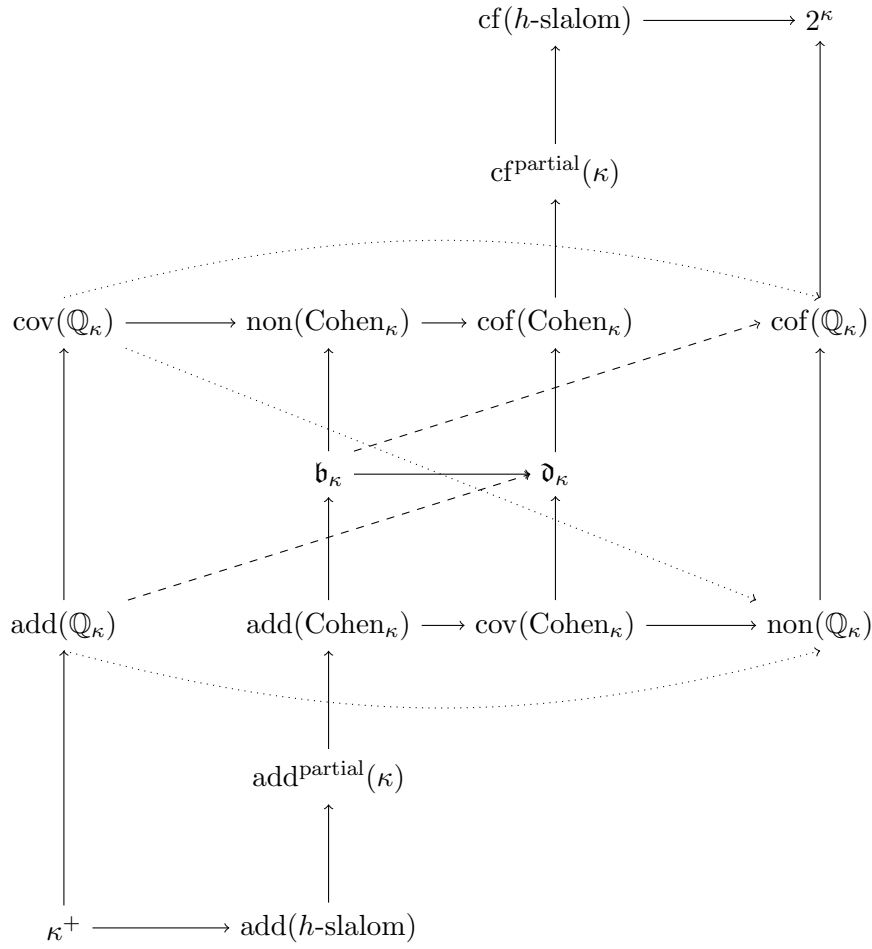

Figure 7.1: The combined diagram: characteristics related to slaloms and $\text{id}(\mathbb{Q}_\kappa)$. Remember that the dashed lines connected to $\mathfrak{b}_\kappa, \mathfrak{d}_\kappa$ require κ Mahlo (or at least S_{pr}^κ stationary).

7.2 Separating Partial Slaloms from $\text{id}(\mathbb{Q}_\kappa)$

The following forcing is used in (Brendle, Brooke-Taylor, Friedman, and Montoya 2018) to show $\text{CON}(\text{add}(h\text{-slalom}) < \text{add}^{\text{partial}}(\kappa))$. We are going to investigate its effect on $\text{id}(\mathbb{Q}_\kappa)$.

Definition 7.2.1. Consider the forcing $\mathfrak{p}\mathbb{L}_\kappa$ consisting of all pairs (ϕ, A) such that

1. $\phi \in \mathfrak{p}\mathcal{C}_{\text{id}}^\kappa$.
2. $A \subseteq \kappa^\kappa$, $|A| < \kappa$.

For $p = (\phi_p, A_p), q = (\phi_q, A_q)$, $p, q \in \mathfrak{p}\mathbb{L}_\kappa$ we define q stronger than p if:

1. $\phi_q \supseteq \phi_p$.
2. $(\text{supp}(\phi_q) \setminus \text{supp}(\phi_p)) \cap \text{sup}(\text{supp}(\phi_p)) = \emptyset$.
3. $A_q \supseteq A_p$.
4. $i \in (\text{supp}(\phi_q) \setminus \text{supp}(\phi_p)), f \in A_p \Rightarrow f(i) \in \phi_q(i)$.

If G is a $\mathfrak{p}\mathbb{L}_\kappa$ generic filter then

$$\phi^* = \bigcup_{(\phi, A) \in G} \phi$$

is a partial slalom and we call ϕ a generic partial slalom. So the intended meaning of $(\phi, A) \in \mathfrak{p}\mathbb{L}_\kappa$ is the promise that the generic partial slalom ϕ^* will satisfy:

1. $\phi \leq \phi^*$.
2. $f \mathfrak{p} \in^* \phi^*$ for every $f \in A$.

Lemma 7.2.2. Let \mathbb{P} be the limit of the $< \kappa$ -support iteration $\langle \mathbb{P}_i, \dot{\mathbb{R}}_i : i < \kappa^{++} \rangle$ where for each $i < \kappa$ we have:

$$\mathbb{P}_i \Vdash \dot{\mathbb{R}}_i = \mathfrak{p}\mathbb{L}_\kappa.$$

Then:

1. \mathbb{P} satisfies $(*)_\kappa$.

2. For each $i < \kappa^{++}$ the forcing \mathbb{P}_i is κ -centered $_{<\kappa}$

Proof.

1. Check that $\text{p}\mathbb{L}_\kappa$ satisfies $(*)_\kappa$ and use 2.2.8.

2. Check that

$$\text{p}\mathbb{L}_\kappa = \bigcup_{\phi \in \text{p}\mathcal{C}^\kappa} \{(\phi, A) : A \in [\kappa]^{<\kappa}\}$$

and use 2.3.7. □

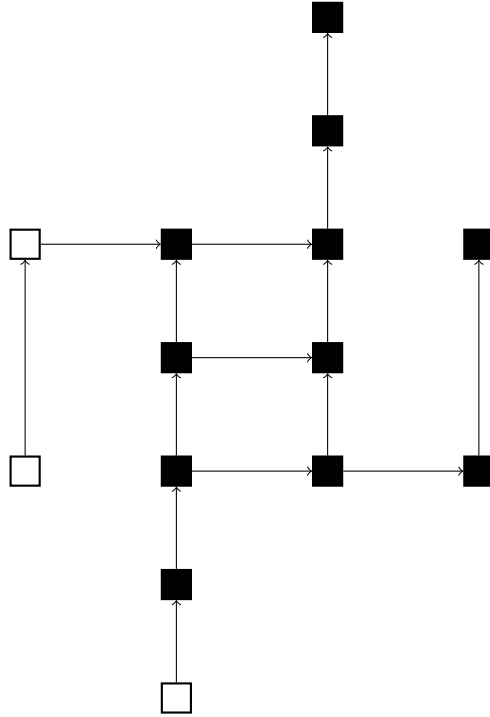

Figure 7.2: Partial slalom model

Theorem 7.2.3. *Let $\mathbf{V} \models 2^\kappa = \kappa^+$. Then $\mathbf{V}^{\mathbb{P}}$ satisfies:*

1. $\text{cov}(\mathbb{Q}_\kappa) = \kappa^+$
2. $\text{add}^{\text{partial}}(\kappa) = \kappa^{++}$
3. $\text{add}(h\text{-slalom}) = \kappa^+$

4. $\text{add}(\text{Cohen}_\kappa) = \kappa^{++}$

5. $2^\kappa = \kappa^{++}$.

Proof.

1. Argue as in 6.2.7.
2. Assume $|\mathcal{F}|$ witnesses $\text{add}^{\text{partial}}(\kappa) = \kappa^+$. Then by the κ^+ -c.c. \mathcal{F} already appears in some \mathbf{V}_α and the generic partial slalom added by \mathbb{R}_α covers every $f \in \mathcal{F}$. Contradiction.
3. This is shown in (Brendle, Brooke-Taylor, Friedman, and Montoya 2018). The argument there is similar to (1.) in the sense that it is shown that κ -centered $<_{\kappa}$ forcings do not increase $\text{add}(h\text{-slalom}) = \kappa^+$.
4. By (3.) and 7.1.4.
5. Should be clear. □

Corollary 7.2.4.

1. $\text{CON}(\text{add}(\mathbb{Q}_\kappa) < \text{add}^{\text{partial}}(\kappa))$.
2. $\text{add}(\mathbb{Q}_\kappa) = \text{add}^{\text{partial}}(\kappa)$ is not a ZFC-theorem. □

7.3 On Total Slaloms and $\text{id}(\mathbb{Q}_\kappa)$

The next conjecture follows from conjecture 5.2.13 (and may be easier to prove):

Conjecture 7.3.1.

1. $\text{CON}(\text{add}(\mathbb{Q}_\kappa) > \text{add}^{\text{partial}}(\kappa))$.
2. In particular also $\text{CON}((\forall h \in \kappa^\kappa) \text{add}(\mathbb{Q}_\kappa) > \text{add}(h\text{-slalom}))$.
3. $(\exists h \in \kappa^\kappa) \text{add}(\mathbb{Q}_\kappa) = \text{add}(h\text{-slalom})$ is not a ZFC-theorem. □

Question 7.3.2. Is $\text{add}(\mathbb{Q}_\kappa) < \text{add}(h\text{-slalom})$ consistent? For a very partial answer see 7.3.4.

Lemma 7.3.3. Let $S \subseteq S_{\text{inc}}^\kappa$ be nowhere stationary. Then we have $\text{add}(h\text{-slalom}) \leq \text{add}(\text{id}^-(\mathbb{Q}_{\kappa,S}))$ if:

1. $\epsilon < \kappa \Rightarrow h(\epsilon) \leq \min(S \setminus (\epsilon + 1))$
2. or at least the above holds on club $E \subseteq \kappa \setminus S$.

Proof. Let

$$\mathcal{A} \subseteq \{\langle A_\delta : \delta \in S \rangle : A_\delta \in \text{id}(\mathbb{Q}_\delta)\}$$

and such that $|\mathcal{A}| < \text{add}(h\text{-slalom})$. We are going to find an upper bound for \mathcal{A} . Let $\langle \epsilon_i : i < \kappa \rangle$, $\epsilon_0 = 0$, increasingly enumerate a club disjoint from S .

For $A \in \mathcal{A}$ we define $f_A : \kappa \rightarrow \kappa$ such that $f(\epsilon)$ codes $A \upharpoonright (\epsilon_i, \epsilon_{i+1})$. Now by our assumption there exists a slalom ϕ such that covers all f_A i.e.

$$(\forall^\infty i < \kappa) f_A(\epsilon_i) \in \phi(\epsilon_i).$$

For $\delta \in (\epsilon_i, \epsilon_{i+1})$ define

$$A_\delta^* = \cup \{X : \text{a code of a sequence } \langle A_\sigma : \sigma \in S \cap (\epsilon_i, \epsilon_{i+1}) \rangle \text{ such that } X = A_\delta \text{ appears in } \phi(\epsilon_i)\}.$$

By our assumption on h we have $\epsilon_i < \min(S \setminus (\epsilon_i + 1)) \leq \delta$ so A_δ^* is the union of at most δ -many elements of $\text{id}(\mathbb{Q}_\delta)$ hence $A_\delta^* \in \text{id}(\mathbb{Q}_\delta)$ and $\langle A_\delta^* : \delta \in S \rangle$ is an upper bound for \mathcal{A} . \square

Corollary 7.3.4. *If all of the following holds:*

1. κ is weakly compact.
2. $\text{add}(\mathbf{nst}_\kappa^{\text{pr}}) > \text{add}(\mathbb{Q}_\kappa)$.
3. h is as in 7.3.3.

Then $\text{add}(\mathbb{Q}_\kappa) \leq \text{add}(h\text{-slalom})$.

Proof. By 7.3.3, 3.2.5 and 3.3.9. \square

List of Figures

5.1	General diagram	72
5.2	Diagram for $\text{add}(\text{Cohen}_\kappa) < \mathfrak{b}_\kappa$	79
5.3	Diagram for $\mathfrak{d}_\kappa < \text{cof}(\text{Cohen})_\kappa$	81
6.1	Cohen model	88
6.2	Hechler model	91
6.3	Short Hechler model	92
6.4	Amoeba model	102
6.5	Short Amoeba model	103
6.6	Bounded perfect tree model	106
7.1	Combined diagram: slaloms and $\text{id}(\mathbb{Q}_\kappa)$	113
7.2	Partial slalom model	115

Bibliography

- Bartoszyński, T. and H. Judah (1995). *Set Theory: On the Structure of the Real Line*. A K Peters, Wellesley, Massachusetts.
- Baumhauer, T., M. Goldstern, and S. Shelah (2018). The Higher Cichon Diagram. *ArXiv e-prints*. arXiv:1806.08583, BhGoSh:1144.
- Blass, A. (2010). Combinatorial cardinal characteristics of the continuum. In *Handbook of set theory. Vols. 1, 2, 3*, pp. 395–489. Springer, Dordrecht.
- Blass, A. (2011). Finite support iterations of σ -centered forcing notions. *MathOverflow*.
- Brendle, J., A. Brooke-Taylor, S.-D. Friedman, and D. C. Montoya (2018). Cichoń’s diagram for uncountable cardinals. *Israel J. Math.* 225(2), 959–1010.
- Cohen, S. and S. Shelah (201x). Generalizing random real forcing for inaccessible cardinals. *Israel Journal of Mathematics submitted*. arxiv:math.LO/1603.08362, CnSh:1085.
- Engelking, R. and M. Karłowicz (1965). Some theorems of set theory and their topological consequences. *Fundamenta Math.* 57, 275–285.
- Friedman, S.-D. and G. Laguzzi (2017). A null ideal for inaccessibles. *Arch. Math. Logic* 56(5-6), 691–697.
- Goldstern, M. and J. Kellner (2016). Review of Uri Abraham’s chapter “Proper Forcing” in the Handbook of Set Theory. *Mathematical Reviews MR2768684*.

- Kanamori, A. (1980). Perfect-set forcing for uncountable cardinals. *Ann. Math. Logic* 19(1-2), 97–114.
- Kanamori, A. (1994). *The higher infinite*. Perspectives in Mathematical Logic. Springer-Verlag, Berlin. Large cardinals in set theory from their beginnings.
- Khomskii, Y., G. Laguzzi, B. Löwe, and I. Sharankou (2016). Questions on generalised Baire spaces. *MLQ Math. Log. Q.* 62(4-5), 439–456.
- König, B. (2006). Chang’s conjecture may fail at supercompact cardinals. arXiv:math/0605128 [math.LO].
- Laver, R. (1978). Making the supercompactness of κ indestructible under κ -directed closed forcing. *Israel J. Math.* 29(4), 385–388.
- Reclaw, I. and P. Zakrzewski (1999). Fubini properties of ideals. *Real Anal. Exchange* 25(2), 565–578.
- Roslanowski, A. and S. Shelah (2006). Reasonably complete forcing notions. *Quaderni di Matematica* 17, 195–239. arxiv:math.LO/0508272, RoSh:860.
- Shelah, S. (1978). A weak generalization of MA to higher cardinals. *Israel J. Math.* 30(4), 297–306. Sh:80.
- Shelah, S. (1998). *Proper and improper forcing* (Second ed.). Perspectives in Mathematical Logic. Springer-Verlag, Berlin.
- Shelah, S. (2000). The Generalized Continuum Hypothesis revisited. *Israel Journal of Mathematics* 116, 285–321. Sh:460.
- Shelah, S. (2017). A parallel to the null ideal for inaccessible λ . *Archive for Mathematical Logic* 56, 319–383. arxiv:1202.5799, Sh:1004.
- Solovay, R. M. and S. Tennenbaum (1971). Iterated Cohen extensions and Souslin’s problem. *Ann. of Math. (2)* 94, 201–245.
- Vojtáš, P. (1993). Generalized Galois-Tukey-connections between explicit relations on classical objects of real analysis. In *Set theory of the reals (Ramat Gan, 1991)*, Volume 6 of *Israel Math. Conf. Proc.*, pp. 619–643. Bar-Ilan Univ., Ramat Gan.