

## Doctoral Thesis

# **MFA as a Decision Support Tool for Resource Management in Emerging Economies - The Case of Optimizing Straw Utilization on Small Farms**

submitted in satisfaction of the requirements for the degree of  
Doctor of Natural Sciences in Civil Engineering  
of the Technische Universität Wien, Faculty of Civil Engineering

---

## Dissertation

# **Materialflußanalyse als Entscheidungshilfe für Ressourcenmanagement – Fallstudie Optimierung der Strohnutzung durch Kleinbauern in aufstrebenden Volkswirtschaften**

ausgeführt zum Zwecke der Erlangung des akademischen Grades eines  
Doktor der Naturwissenschaften  
eingereicht an der Technischen Universität Wien Fakultät für Bauingenieurwesen  
von

Kulwadee Tongpubesra EISINGERICH, M.Sc.  
Matrikelnummer 1128574  
Institute for Water Quality, Resource and Waste Management

Gutachter: Professor Paul Hans Brunner  
Institute for Water Quality, Resource  
and Waste Management,  
Technische Universität Wien

Gutachter: Professor Jens Christian Tjell  
Professor emeritus  
DTU Environment  
Technical University of Denmark

## Acknowledgements

First of all, I wish to express my deepest gratitude to Prof. Paul Hans Brunner, my advisor, for the invaluable comments, constructive criticism, and suggestions to guide me through this thesis during numerous consultations. His patient understanding and generosity, as well as his confidence in my capacity to conduct research from overseas stimulated me to bring this thesis to a good end.

I wish to express my sincere gratitude to my examiner, Prof. Jens Christian Tjell for the valuable comments to further improve the thesis.

My thankfulness also go to DI Oliver Cencic. With his generous guidance to help me resolve STAN's issues with the complexities of agriculture system and nature, my STAN simulations could finally be operated successfully.

I would also like to thank Dr. Markus Mueller for our multiple research discussions as well the support staff of the Institute for Water Quality, Resource and Waste Management (IWA) at the *TU Wien*, who always provided their timely assistance in the complicated matters of administration and coordination as I was working from overseas.

Furthermore, I would like to thank Mrs. Pratin Somsap who coordinated and accompanied me to interview the farmers of her network. Without her support, that data would not have been collected successfully.

Finally, I would like to thank my family. My small daughter, who was patient and understanding to allow me working intensively without any disturbance. My parents for their moral support, inspiring me to reach this goal, my mother in law for her backup and help to take care of my family in Australia while I was studying alone in Vienna for the coursework. Last but not least, I wish to express my thankfulness and appreciation to my husband who gave uncountable support as the permanent backup for our daughter as well as for spending long hours of reading and commenting on the grammar and contents of this thesis.

## Abstract

Due to the scarcity of land for cultivation especially in Asian countries, the lack of knowledge about rice straw management and its environmental consequences, as well as low opportunities for income, large amounts of biomass residues are being burnt by farmers on-site after harvesting. Such "Rice straw open burning" (RSOB) wastes nutrients like Nitrogen and Phosphorus, and emits pollutants causing environmental and health problems. RSOB is also contributing to declining soil fertility resulting in rather low yields in paddy rice fields.

The goal of this thesis is to develop a methodology for simulating the economic and environmental effectiveness of rice straw management considering knowledge and financial limitations of small farm holders. To reach the objectives, the concepts of Material Flow Analysis (MFA), Substance Flow Analysis (SFA), Scenario Analysis, and Economic Analysis (EA) are applied for assessing straw management on a hectare of an exemplary farm in view of resource management practice, environmental consequences, and economic advantages. Data and statistics for describing the farm by the software STAN are collected from national and international organizations, including data by satellite imageries and from personal interviews.

Based on stoichiometric equations and mass balances, process equations for Status Quo and four scenarios are developed. The scenario results serve to design an optimized scenario, a combination of simple technologies for straw management allowing farmers to utilize straw for producing food, feedstock, energy, and construction material. By optimizing straw management, emissions of 800 kg CO<sub>2e</sub>/y.ha, of 110 kg/y.ha CO, and of 11 kg/y.ha particulate matter (PM) affecting climate change and public health are eliminated. In addition, substances previously released to the environment are transformed into food and feed products, in biogas, and in straw bricks. At the same time, economic profits for farmers increase 4.7 times, motivating stakeholders to change their straw management.

This research shows the potential of combining MFA (STAN), SFA, EA, and scenario analysis to improve resource management, environmental management, and human health, and at the same time to increase farming profits.

## Terms and Abbreviations

### Terms

Aerosol - The small particles suspended in air, e.g. dust, or formed by the conversion of e.g. nitrogen oxides, ammonia and organic compounds in atmospheric chemical reactions (Slanina, 2013)

Available Nitrogen for plants : Nitrogen that can be uptaken by plants

Available Phosphorus for plants : Phosphorus that can be uptaken by plants

Atmosphere - the envelope of gases surrounding Earth (CCPO, 2003)

Emerging Economies - countries with low to middle per capita income. They are in the process of moving from a closed economy to an open market economy while building the accountability within the system. They are also most likely receiving aid and guidance from large donor countries and/or world organizations. The local politics and social factors are always influent on their economic stability and reliability (Heakal, 2003)

Hydrosphere - Discontinuous layer of water at or near Earth's surface. It includes all liquid and frozen surface waters, groundwater held in soil and rock, and atmospheric water vapor (Encyclopedia Britannica Online, 2015)

Mineralization - Process through which an organic substance becomes impregnated by or turned into inorganic substances (Vert et al, 2012)

Particulate Matter (PM) - The total mass of aerosols per unit of volume, e.g. PM<sub>10</sub> represents the mass of aerosol particles with a diameter of 10 micrometers or smaller. PM<sub>2.5</sub> is the mass of aerosol particles with a diameter of 2.5 micrometers or smaller (Slanina, 2013)

Pedosphere - Relatively thin soil layers found on top of much of Earth's land surface, processes interacting between the lithosphere, atmosphere, hydrosphere, and biosphere resulting in the formation of individual soil units with unique properties across the landscape (CCPO, 2003).

Soil fertility - the ability of the soil to supply essential plant nutrients and water in adequate amounts and proportions for plant growth and reproduction in the absence of toxic substances which may inhibit plant growth (FAO, 2015).

Total Nitrogen in soil - The sum of nitrate, nitrite Nitrogen, and Total Kjeldahl Nitrogen (ammonia, organic and reduced nitrogen) existing in soil (EPA, 2013)

Total Phosphorus in soil - The sum of total inorganic, organic, soluble and insoluble phosphorus e.g. orthophosphate, condensed phosphate, and organic phosphate existing in soil

### Abbreviations for chemical elements and compounds

C	- Carbon
N	- Nitrogen
P	- Phosphorus
CO <sub>2</sub>	- Carbon Dioxide
CH <sub>4</sub>	- Methane
N <sub>2</sub> O	- Nitrous Oxide
CO <sub>2</sub> e	- Carbon Dioxide equivalent
CO	- Carbon Monoxide
NH <sub>3</sub>	- Ammonia
NO <sub>2</sub>	- Nitrogen Dioxide
OC	-Organic Carbon
OM	- Organic Matter
SOC	- Soil Organic Carbon
VS	- Volatile Solid

### Other abbreviations in this study

approx. - approximately

HH - House Hold

kg/y.ha - kilograms per year per hectare

OAE - Office of Agricultural Economics, Thailand

RSM - Rice Straw Management

RSOB - Rice Straw Open Burning

SMS - Spent Mushroom Substrate

USD - U.S. Dollar (at the rate 1 USD = 30 THB)

THB - Thai Baht

## Table of Contents

	<b>Page</b>
<b>Acknowledgements</b>	<b>ii</b>
<b>Abstract</b>	<b>iii</b>
<b>Terms and Abbreviations</b>	<b>iv</b>
<b>List of Tables</b>	<b>vii</b>
<b>List of Figures</b>	
<b>Chapter 1. Introduction</b>	<b>1</b>
1.1. Problem definition	1
1.1.1. Environmental problems	2
1.1.2. Human health problems	2
1.1.3. Low resource efficiency	3
1.2. Scope of thesis	4
1.3. Hypothesis	5
1.4. Objectives	5
1.5. Research questions	5
<b>Chapter 2. Literature Review</b>	<b>6</b>
2.1. Global rice production and rice production in emerging economies	6
2.2. Production and management of rice straw by small farms in Thailand	7
2.2.1. Characteristics of small farms in Thailand	7
2.2.2. Agricultural soil at present	7
2.2.3. Rice cultivation- the source of straw	11
2.2.4. Rice straw management (RSM) of small farms at present	12
2.3. Rice Straw Open Burning in Thailand (RSOB)	
2.3.1. Identification and quantification of straw burning area	15
2.3.2. Characteristics of air pollutants from RSOB	15
2.3.3. Impacts of RSOB	17
2.4. Possible technologies for utilizations of straw and RSM residues in small farms	20
2.4.1. Straw for mushroom production	20
2.4.2. Straw as a main animal feedstock	21
2.4.3. Straw for construction materials	22
2.4.4. Straw and RSM residues for producing alternative energy	23
2.4.5. Straw and RSM residues for aquaculture	25
2.4.6. RSM residues as soil fertilizers	27

## Table of Contents (continued)

	<b>Page</b>
<b>Chapter 3. Methodology</b>	<b>28</b>
3.1. Definition of exemplary small-scale Thai farm system	28
3.2. Developing a Rice Straw Management (RSM) model	30
3.2.1. Concept for studying a RSM model	30
3.2.2. Tool to study RSM	32
3.3. Data selection and uncertainty	32
3.4. Analysing and Evaluating of model	33
3.5. Quantification of Status Quo	34
3.5.1. Concept for developing the model "Status Quo"	34
3.5.2. System development for "Status Quo"	37
3.6. Scenario analysis	47
3.6.1. Goal of scenario analysis	47
3.6.2. Developing of scenarios	47
3.7. Designing an optimized scenario for straw utilization	62
3.7.1. Concept of an optimized scenario	62
3.7.2. Adjusting of the existing processes from Status Quo and improved Scenarios	64
3.7.3. The additional Processes for optimized scenario	65
<b>Chapter 4. Results and Discussion</b>	<b>69</b>
4.1. Actual results	69
4.1.1. Actual results from Status Quo from an exemplary farm	69
4.1.2. Scenario analysis per ha of improved RSM in a small farm	77
4.1.3. Actual results from the optimized scenario	105
4.2. Answers to the research questions	116
4.3. Interpretation	119
4.3.1. Interpretation in terms of environment	119
4.3.2. Interpretation in terms of resource management	120
4.3.3. Interpretation in term of economics	121
4.3.4. Interpretation of integrative technologies in Optimized Scenario	122
<b>Chapter 5. Conclusion and Recommendation</b>	<b>123</b>
<b>References</b>	<b>127</b>
<b>Annex</b>	<b>145</b>
<b>Curriculum Vitae</b>	<b>155</b>

## List of Tables

<b>Tables</b>	<b>Page</b>
2.1. Ratio of rice straw to paddy grain from different studies	12
2.2. Pollutant emissions from RSOB in Thailand	16
2.3. Life-time and Global Warming Potential (GWP) of GHG from RSOB	19
2.4. Consumption of biogas for different activities and compared to other fuels	24
3.1. Indicators to assess the effectiveness of Scenarios compared with Status Quo	33
4.1. Material and substance dynamics per ha from RSM in Status Quo of an exemplary farm in 2011	70
4.2. Material and substance dynamics per ha from RSM in Scenario A "Food" of an exemplary farm in 2011	77
4.3. Material and substance dynamics per ha from RSM in Scenario B "Fodder" of an exemplary farm in 2011	83
4.4. Material and substance dynamics per ha from RSM in Scenario C "Energy" of an exemplary farm in 2011	89
4.4. Material and substance dynamics per ha from RSM in Scenario D "Construction of an exemplary farm in 2011	95
4.5. RSM products from optimized scenario	105
4.6. Material and substance dynamics per ha from RSM in the optimized scenario of an exemplary farm in 2011	106
4.7. Input flows, output flows, and stock of model Status Quo	116
A1. Data for MFA calculation in Status Quo	146
A2. Data for MFA calculation for scenario analysis	149
A3. MFA data for calculating model "Optimized Scenario"	152
A4. Economic data for an exemplary small farm in Thailand	154



## List of Figures

<b>Figures</b>	<b>Page</b>
1.1. main air pollutants from RSOB	1
2.1. Global rice production in year 2011	6
2.2. Area for rice cultivation in Thailand at year 2011	9
3.1. General description of an exemplary small Thai farm for rice cultivation in 2011	29
3.2. MFA per ha in "Status Quo" on an exemplary farm in 2011 (no values shown)	36
3.3. Subsystem in process "RSOB"	38
3.4. Subsystem in process "Chemical Distribution"	41
3.5. Subsystem in process "Trade&Profit"	42
3.6. Environmental subsystem "Pedosphere and Hydrosphere"	43
3.7. Environmental subsystem "Atmosphere"	46
3.8. Subsystem Process "Baling"	49
3.9. MFA per ha in Scenario A "Food" on an exemplary farm in 2011 (no values are shown)	51
3.10. Subsystem of process "Chemical Distribution"	53
3.11. Subsystem of process "Livestock Digestion"	54
3.12. MFA per ha in Scenario B "Fodder" on an exemplary farm in 2011 (no value are shown)	55
3.13. MFA per ha in Scenario C "Energy" on an exemplary farm in 2011 (no values are shown)	57
3.14. Subsystem of Process "Biogas Digestor"	58
3.15. MFA per ha in Scenario D "Construction" on an exemplary farm in 2011 (no values are shown)	60
3.16. Subsystem of Process "Straw Brick"	61
3.17. MFA per ha in optimized scenario on an exemplary farm in 2011 (no values are shown)	63
3.18. Subsystem of Process "Duckweeds"	66
3.19. Subsystem of Process "Tilapia"	67
4.1. Pollutant emission from RSOB in Status Quo	69
4.2. Material flows (Layer Goods) per ha in Status Quo on an exemplary farm in 2011	71
4.3. Carbon flows (Layer C) per ha in Status Quo of an exemplary farm in 2011	72
4.4. Nitrogen flows (Layer N) per ha in Status Quo on an exemplary farm in 2011	73
4.5. Phosphorus flows (Layer P) per ha in Status Quo on an exemplary farm in 2011	74
4.6. Cost and profit flows (Layer Money) per ha in Status Quo on an exemplary farm in 2011	75

## List of Figures (continued)

<b>Figures</b>	<b>Page</b>
4.7. Material flows (layer Goods) per ha in Scenario A "Food" of an exemplary farm in 2011	78
4.8. Carbon flows (layer C) per ha in Scenario A "Food" on an exemplary farm in 2011	79
4.9. Nitrogen flows (layer N) per ha in Scenario A "Food" on an exemplary farm in 2011	80
4.10. Phosphorus flows (layer P) per ha in Scenario A "Food" on an exemplary farm in 2011	81
4.11. Material flows (layer Goods) per ha in Scenario B "Fodder" on an exemplary farm in 2011	84
4.12. Carbon flows (layer C) per ha in Scenario B "Fodder" on an exemplary farm in 2011	85
4.13. Nitrogen flows (layer N) per ha in Scenario B "Fodder" on an exemplary farm in 2011	86
4.14. Phosphorus flows (layer P) per ha in Scenario B "Fodder" on an exemplary farm in 2011	87
4.15. Material flows (layer Goods) per ha in Scenario C "Energy" on an exemplary farm in 2011	90
4.16. Carbon flows (layer C) per ha in Scenario C "Energy" of on exemplary farm in 2011	91
4.17. Nitrogen flows (layer N) per ha in Scenario C "Energy" on an exemplary farm in 2011	92
4.18. Phosphorus flows (layer P) per ha in Scenario C "Energy" on an exemplary farm 2011	93
4.19. Material flows (layer Goods) per ha in Scenario D "Construction" on an exemplary farm in 2011	96
4.20. Carbon flows (layer C) per ha in Scenario D "Construction" on an exemplary farm in 2011	97
4.21. Nitrogen flows in (layer N) per ha Scenario D "Construction" on an exemplary farm in 2011	98
4.22. Phosphorus flows (layer P) per ha in Scenario D "Construction" of on an exemplary farm in 2011	99
4.23. GHG emission from Status Quo and all scenarios	101
4.24. Primary emissions of substances to the atmosphere from Status Quo and all scenarios	101
4.25. Substance accumulations in the hydrosphere from Status Quo and all scenarios	102
4.26. Substance accumulations in farm soil from Status Quo and all scenarios	102

## List of Figures (continued)

<b>Figures</b>	<b>Page</b>
4.27. Substance distributions to RSM products from Status Quo and all scenarios	103
4.28. Total investment in the first year RSM-operation for Status Quo and all scenarios	103
4.9. Net economic profit in Status Quo and all scenarios	104
4.30. Material flows (Layer Goods) per ha in the optimized scenario on an exemplary farm in 2011	107
4.31. Carbon flows (Layer C) per ha in the optimized scenario on an exemplary farm in 2011	108
4.32. Nitrogen flows (Layer N) per ha in the optimized scenario on an exemplary farm in 2011	109
4.33. Phosphorus flows (Layer P) per ha in the optimized scenario on an exemplary farm in 2011	110
4.34. Cost and profit flows (Layer Money) per ha in optimized scenario on an exemplary farm in 2011	111
4.35. Primary emissions of air pollutants from Status Quo and optimized scenario	113
4.36. Primary emissions of substances to the atmosphere from Status Quo and optimized scenario	113
4.37. Substance accumulations in the hydrosphere from Status Quo and optimized scenario	114
4.38. Substance accumulations in farm soil from Status Quo and optimized scenario	114
4.39. Substance distributions to RSM productions from Status Quo and optimized scenario	115
4.40. Net economic profit in Status Quo and optimized scenario	115

# Chapter 1

## Introduction

### 1.1. Problem definition

Emerging Economies are big producers of rice and most of them are located in Asia (OAE, 2012). More than 1.2 million km<sup>2</sup> of land on this continent is used to grow rice. Large amounts of straw biomass, i.e. the main by-product from rice cultivation, are being burned on-site before cultivating the next crop. Street *et al* (2003) reported that biomass burning of forest and agricultural residues emit 20-30% of total emissions of air pollutants in Asia. Rice Straw Open Burning (RSOB) is an uncontrolled and incomplete combustion process which emits air pollutants such as CO<sub>2</sub>, CO, CH<sub>4</sub>, Particulate Matter (PM) as well as other gases (Koppmann *et al*, 2005) as shown in Fig. 1.1. are causing the following problems:

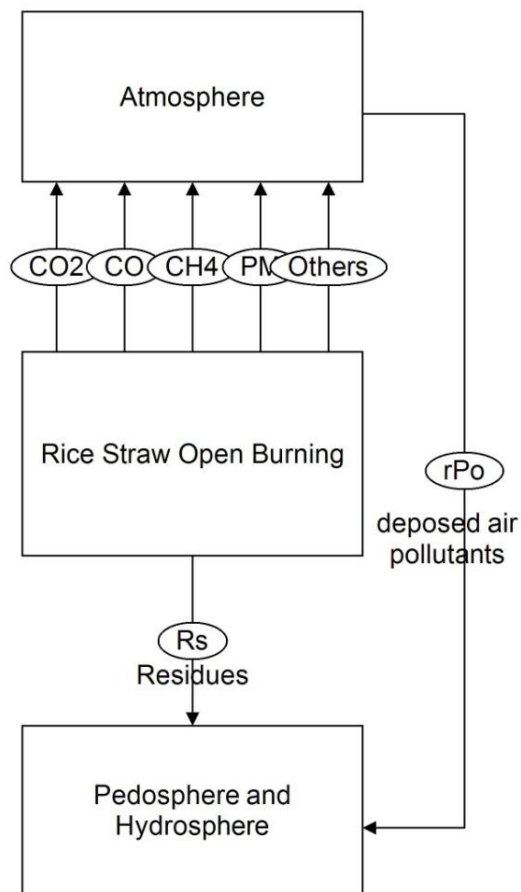

Fig. 1.1. main air pollutants from RSOB

### 1.1.1. Environmental problems

RSOB not only emits CO<sub>2</sub>, a green house gas (GHG), but it also emits many primary pollutants e.g. CO, CH<sub>4</sub>, NO<sub>x</sub>, Volatile Organic Carbon (VOC) which impact on the Ozone formation in the troposphere thus increasing climate change.

PM from RSOB is also deemed to be part of periodic Haze Episodes in many countries affecting human health and environment. PM can be carried over distances and deposited to soil and water causing nutrient change in those environments. US-EPA (2013) reported that PM<sub>2.5</sub> is the main cause of visibility impairment. PM which are deposited in city areas tentatively even stain material surfaces. The Department of Pollution Control (DPC, Thailand) reported that "Haze Episodes" especially in Northern Thailand were directly related to the hotspots from open burning of forest and agriculture residues after each harvesting in Thailand and surrounding countries; a study of Tai-Yi (2012) also mentioned that air quality was highly related to straw burning. Although ASEAN agreed to develop a common policy and to implement a plan to control burning in order to solve Haze's problems (Garivait *et al*, 2007), the phenomenon still exists due to lack of cooperation from farmers as well as of reliable monitoring of on-going RSOB.

### 1.1.2. Human health problems

The air pollutants mentioned above have raised awareness of a public health problem. Not only do they release CO, quantitatively the second biggest air pollutant from RSOB after CO<sub>2</sub> (Chang *et al*, 2013) reducing oxygen transportation in blood (EPA, 2015), they also release toxic smoke containing e.g. VOC, Carcinogenic Polycyclic Aromatic Hydrocarbon (PAHs), together with the most crucial pollutant PM (WHO, 1999). EPA (2013) warns that PM smaller than 10 µm can irritate eyes and the respiratory system by penetrating into the lung and bloodstream, thus affecting lung and heart. The problems resulting from PM in the dry season are more relevant than those in the rainy season during which PM can be deposited by rain. These problems are also more severe in an area with geographical limits such as mountains, since the pollutants can accumulate longer in the atmosphere. Although these problems have been recognized and studied since 2004 at local, regional and country level in Thailand, the amount of air pollution still remains beyond acceptable limits of PM concentration in the atmosphere. For example, the average pollution of PM<sub>2.5</sub> in 24 hours from January to April 2012 was the highest at Mae Sai, Chiang Rai, Thailand (471 µg/m<sup>3</sup>), i.e. almost ten times higher than the maximum limit defined by the DPC, Thailand (namely 50 µg/m<sup>3</sup>).

Statistic data from the Faculty of Medicine, Chiang Mai University-Thailand showed that concentration of PM<sub>10</sub> higher than 50 µg/m<sup>3</sup> in the atmosphere increases the number of the patients suffering from Asthma and Chronic obstructive pulmonary disease (COPD) by 3.5 times (Simachaya, 2011). Prapamongkol *et al* (2012) reported that the area in Chiang Mai where hotspots from burning were detected, had higher amounts of PM in the atmosphere. The children in these areas had higher 1-Hydroxypyrene (1-HOP), a metabolite intermediate of PAHs from burning, in their urine. Their respiratory problems increased according to the amount of PM detected, and were more prevalent than those from in other areas.

In addition, the carcinogenic compounds from RSOB might also be another cause of lung cancer in men and women especially in the area of northern Thailand. Statistic data from Lampang's Cancer hospital (2012) showed that the highest rate of lung cancer in Thailand was found in men and women from Northern Thailand. Furthermore, lung cancer in Thai women in Northern Thailand was even the highest in Asia (Polpibool *et al*, 2014), although wood and coal's stove cooking -a possible cause for lung cancer- is not as prevalent there as in the past anymore. The Department of Disease Control (DDC) Thailand reported that 950,000 patients in Northern Thailand were affected by the Haze Episode with costs estimated at 390 million Bahts or 13 million USD (DPC, 2013).

To counter the scourge, local authorities in Thailand have been taking action with a "Stop Burning" Campaign, but problems still linger on.

### 1.1.3. Low resource efficiency

From long-term use of land for rice cultivation, the soil has been continuously losing nutrients, e.g. N and P. 35 million ha in Thailand have had a problem of soil and nutrient depletion (Ministry of Agriculture and Cooperatives (MAC) Thailand, 2015). 16 million ha of soil in Thailand contained OM lower than 1.5%, especially soil in Northeastern Thailand. As the majority of agricultural land in Thailand is used for rice cultivation (Land Development Department (LDD) Thailand, 2011), most of paddy field's soil in Thailand is assumed to have this problem. The decrease of C stock in soil is also caused by long term land uses for agriculture (IPCC, 2007). In addition, paddy soil encounters high soil respiration and leaching by water drainage at the end of rice cultivation, thus causing the loss of organic nutrients in soil as well (Cui *et al*, 2013).

Small farm holders not only have a lack of knowledge how to manage rice straw efficiently, but are also lacking land. RSOB is therefore the method they use for eliminating this agricultural by-products as fast as they can in order to either use their land for the next cash crop cultivation, or working off-farm to increase their family income. They cannot leave straw degrading naturally on the field because it might cause fungal and insect contamination and affect their next crop. RSOB by farmers at the end of each cultivation period therefore releases of soil nutrients -absorbed in straw- into the atmosphere, carrying them away by wind and depositing them at further distance.

The effect of nutrient depletion in soil from improper RSM besides long term land use for rice cultivation, can be observed from the yield of paddy grain produced in Thailand. From statistic data of rice production from different countries in year 2011 (OAE, 2012), the yield of paddy grain from Thailand was 3200 kg/ha, i.e. only 41% of the rice production's yield in the USA (7900 kg/ha) in the same year (FAO, 2011). The highest record of individual production was achieved by Sunan Kumar, an Indian farmer who gained 22 tons/ha (Vidal, 2013), though the accuracy of this data has been questioned.

Farmers have tried to compensate the nutrient depletion in soil by overusing chemical fertilizers in order to improve the yield of rice production (Verapat, 1977; Junnual and Klangasuk, 2012), thus increasing the problem of water contamination on top of the existing problems of air pollution by RSOB. Overusing of fertilizers by farmers increases the costs of rice production and affects farm's economics. According to a report from OAE (2012), 5.8 million farms in Thailand earned only a low income, 37-39% of which was from agriculture. Their economic problems are further increased by the above mismanagement of fertilizers.

## 1.2. Scope of thesis

Due to the lack of comprehensive or integrative studies on economic, environmental, and resource efficiency at small farm level, this thesis studies the problems and possible solutions that a farmer, as a decision maker, could handle by himself, namely reducing emissions causing problems for health, environment, as well as improving resource efficiencies in terms of C, N, P at individual, local and global levels.

Proper technologies and management schemes are selected to divert the emitted substances from straw burning into more appropriate sinks e.g. food, fodder, energy, and construction materials. Hence, the selected technology can improve resource efficiency which in turn reduces negative effects on the environment and public health. However, as the farmer's income is their main concern, these suitable technologies should increase the economic benefits to motivate the farmers to implement them.

Thailand is selected as a study case of an emerging economy as it is i) one of the top ten rice producers (OAE, 2012), rice being their biggest agriculture crop for worldwide export, and ii) data collection was comparatively easy because of the writer's access to Thai data. C, N, P were focused on as the main substances in rice plants as well as the main constituents of relevant living organisms, farm products, and pollutants related to straw utilizations in small farms, allowing for the observation of nutrient balances of the whole straw management in farms

### **1.3. Hypothesis**

MFA and Economic analysis are instrumental for the solution of problems at the three relevant levels mentioned in 1.2.

### **1.4. Objectives**

As the goal of this thesis is to develop a methodology for simulating the efficiency of straw management in Thailand based on lack of knowledge as well as financial limitations of small farm holders, the objectives for this study are as follows:

1.4.1. to develop a model and analyze the Status Quo in view of Rice Straw Management (RSM) and economics using MFA, SFA, and EA via STAN of Status Quo of small farms in Thailand.

1.4.2. to develop and analyse scenarios of proper technologies in different schemes for small farms to solve the problems of resource availability, as well as environmental, economics, and health issues.

1.4.3. to combine the results of scenario analysis in order to develop an optimized small farm straw management system

1.4.4. to demonstrate the advantages of the optimized system in terms of environment, resource management, and economics for a household management system at individual, local, and global level.

### **1.5. Research Questions**

1.5.1. How to define the model farm (Status Quo)

1.5.2. How to model RSM in small Thai farms by MFA, SFA, EA

1.5.3. How to select the data for MFA, SFA, EA

1.5.4. How to reduce uncertainty

1.5.5. What are appropriate criteria to select technologies for improving scenarios

1.5.6. What should be the criteria to combine technologies for an optimized scenario

1.5.7. What are suitable indicators for assessing the effectiveness of each scenario



## Chapter 2

### Literature Review

#### 2.1. Global rice production and rice production in emerging economies

OAE (2012) reported that global rice production in 2011 was 722 million tons. The 10 biggest rice producers were China, India, Indonesia, Bangladesh, Vietnam, Thailand, Burma, the Philippines, Brazil, and Cambodia. Most of them are Asian emerging economies (IMF, 2012), as shown in Fig 2.1.

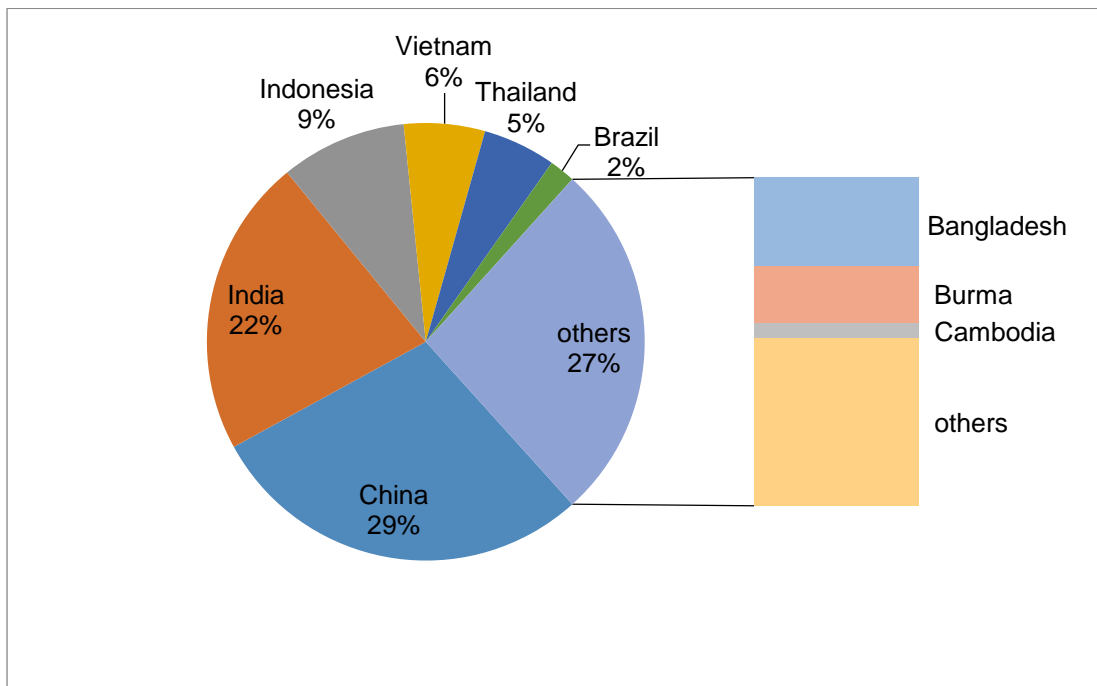

Fig. 2.1. Global rice production in year 2011  
source: OAE, 2012

Small farms are a main factor in agricultural economics and rice cultivation in Asia (Devandra, 1980). Nagayets (2005) reported from data of the FAO and national statistic agencies that 87% of small farms were located in Asia. The size of small farms varies from country to country. FAO (2010) reported that the global average size of small farms was 5.5 Ha. Hazel *et al* (2007) reported FAO-data from 1978-2003 according to which the farm size in Thailand was approximately 3 Ha while in other countries in the developing world, it varied from less than 1 Ha to 11 Ha (1970-2002). However, the decisive criteria for categorizing small farms is not only farm size, but also e.g. farm income, source of labourers, as well as technologies used in the farms.

This study focuses on rice straw utilization of small farms in Thailand as mentioned in Chapter 1. The main literature about rice straw production and utilization in Thailand are hereby reviewed and used as references.

## **2.2. Production and management of rice straw in Thailand**

### **2.2.1. Characteristics of small farms in Thailand**

The average farm size in Thailand changed from 2.7 Ha in 1976 (Devandra, 1993) to 4.1 Ha in 2011 (OAE, 2012). 75% of the rice farm's area in 2011 was used for cultivating rice. In general, household members are the main labourers on the farm. The machineries e.g. tractors are rented when needed, e.g. during plantation and harvesting stage. Farmers raise ruminant livestock rather for meat production than drafting unlike in the past. Some households also raise non-ruminant livestock e.g. chicken or pigs. Small farm holders traditionally manage livestock production by tethering cattle on small plots nearby their house or their rice field.

### **2.2.2. Agricultural soil at present**

#### **2.2.2.1. Factors indicating soil fertility**

To understand the present situation of agricultural soil in Thailand, soil fertility needs to be mentioned. FAO (2006) defines the meaning of "soil fertility" as "the ability of the soil to supply essential plant nutrients and soil water in adequate amounts and proportions for plant growth and reproduction in the absence of toxic substances which may inhibit plant growth". Soil fertility is indicated from physical properties, e.g. soil aggregation and porosity, from chemical properties, e.g. pH, OM, N, available P (LCD and FAO, 1973), including biological properties like soil biota.

OM improves soil structure by better aggregation (Hongkul *et al*, 2014) and soil density (Deejring and Sa-nguanpong, 2014). The Organic carbon (OC) in soil is mineralized then partly converted to stable C, e.g. organic C in humus, organic-material compounds, as well as polymers. The stable C from mineralization has a long residence time in soil (Corsil *et al*, 2012). Some organic acids from OC mineralization can increase soil fertility, bringing a positive effect on farm productivity (Leu, 2007).

Organic N improves available N in soil, thus increasing soil fertility (Cong *et al*, 2014). Percentage of OM in soil indicates the level of N in soil. A study by Koyama *et al* (1973) showed that 60% of N used as rice nutrients are from N mineralization of organic matter in soil.

Although there is plenty of P in soil. However, available P in soil that plants can uptake is generally limited due to P fixation of P by Cation in soil e.g. ion of Ca, Al, Fe (CTAHR, 2015). OM helps to increase the available P in soil by reducing the binding of P and these ion (Violante and Huang, 1989). Furthermore, OM also forms complexes with organic phosphate hence increasing phosphate uptaken by plants. It also acts as a P source via mineralization in soil (CTAHR, 2015).

Substances from top layer are slowly translocates from top to the lower layer by water that drains through the soil. OC that is moved to a lower depth than 50 cm is stable and takes 50-100 years to degrade (Jai-ree, 2007; Bernoux, 1998). The mineralization and translocation of C in soil also similar to those of N and P (Manzoni and Porporato, 2009).

#### 2.2.2.2. Characteristics of Fertile Soil in Thailand

To compare soil fertility and stocks of substances, the best reference for fertile soil would be forest soil without land use. Soil at 1 m depth contains 1550 Pg organic C and 750 g inorganic C (Batjies, 1996). Dixon *et al* (1994) mentioned that undisturbed soil in tropical forest contains 250 tons C/ha. In Thailand, Pibumrung *et al* (2008) reported that C stock in a forest soil in Northern Thailand was 200 tons C/ha at top soil layer (0-30 cm). Del Datta *et al* (1981) assumed that 1960 kg N/ha existing in 10 cm-depth soil with soil bulk-density of 1.3 g/cm<sup>3</sup> could be utilized for rice cultivation for 13 years without fertilizers or biological degradation to compensate fertility losses. A study of Jai-aree (2007) showed that a forest soil in Thailand at 0-30 cm depth contained 8.1 tons N /ha and 89 kg available P/ha.

#### 2.2.2.3. The Changes of substance stocks by agriculture

Due to long term agriculture, soil fertility and substance stocks in soil have decreased (IPCC, 2006) as follows:

##### A) C stock in agricultural soil

Changing from forest or grassland to crop-cultivation causes app. 50% of C loss in soil (Guo and Gifford, 2003; Funakawa *et al*, 2012; Stewart 2014; Pibumrung *et al*, 2008). This loss is higher in tropical regions than in subtropics (Kawaguchi and Kyuma, 1976). Jai-aree (2007) reported that 47% of existing Soil Organic Carbon (SOC) was lost in 12 years by corn cultivation while its OC, newly accumulated from agriculture, increased only by 10% during the same period. Anurakipan (2012) studied the C stock at agricultural soil surface (0-15 cm depth) in Thailand and reported the average C stock of agricultural soil in Thailand was 1.9% (39 tons C/ha at soil bulk-density mainly 1.4 g/cm<sup>3</sup>). The highest C stock in agricultural soil in 2011 was 17% (360 tons C/ha). Cha-un *et al* (2010) reported the substance content in low fertility long term agricultural soil of Rachaburi Province after it was abandoned for many years. Its C stock at 0-15 cm and 15-30 cm depth was 11 tons C/ha and 6.2 tons C/ha, respectively. 56% of C were in the top layer, i.e. a similar proportion to that in forest soil.

##### B) Using soil as a sink for C sequestration

Returning C back to soil is not only recovering the amount of C stock, but also reducing C emitted e.g. as GHG to the atmosphere. Carbon sequestration in soil removes C from the atmosphere and subsequently transforms and accumulates it as OM in plants. Afterwards, their debris in soil decomposes and captures C as SOC. Soil is an important sink for C as its C is a more

stable form than that in living organisms (Cha-Un *et al*, 2010). Lal, the director of Ohio State University's Carbon Management and Sequestration Center also advised in an interview to return carbon into soil as a main C sink. Efficient C-sequestration can restore 1-3 billion tons/y C from 11 billion tons CO<sub>2</sub> emitted to the atmosphere (Schwartz, 2014). Soil offset projects (as C credits for soil sequestration on agricultural land) have been supported by IPCC for the C market (Ignosh *et al.*, 2009). The agricultural sector in Asia has a high potential as a soil carbon sink (Tawprayoon *et al*, 2013). Anuraktipan (2012) reported that 350-420 kg/ha of C in agricultural soil in Thailand was lost every year. He recommended that adding the same amounts of C from organic litter into the soil could compensate the C loss and maintain its equilibrium in soil.

### C) N and P stocks in agricultural soil

Total N and available P in soil also decrease by long term and intensive agriculture. Funakawa *et al* (2012) reported that 3.9 g N/kg of forest soils in Asia were reduced to 2.2 g N/kg in cropland soil. Anuraktipan (2012) reported that N in agricultural soil in Thailand decreased on average from 0.17% (2010) to 0.14% N in 2011 (from 3.6 to 2.9 tons N/ha). Cha-un *et al* (2010) reported that total N in an abandoned agricultural soil was 1.1 tons/ha while available P was only 10.5 kg/ha.

### D) Soil fertility in Thai rice farms

The state of the soil on Thai rice farms is estimated from the fertility of the soil in the major areas for rice cultivation. The geographical repartition is shown in Fig. 2.2.

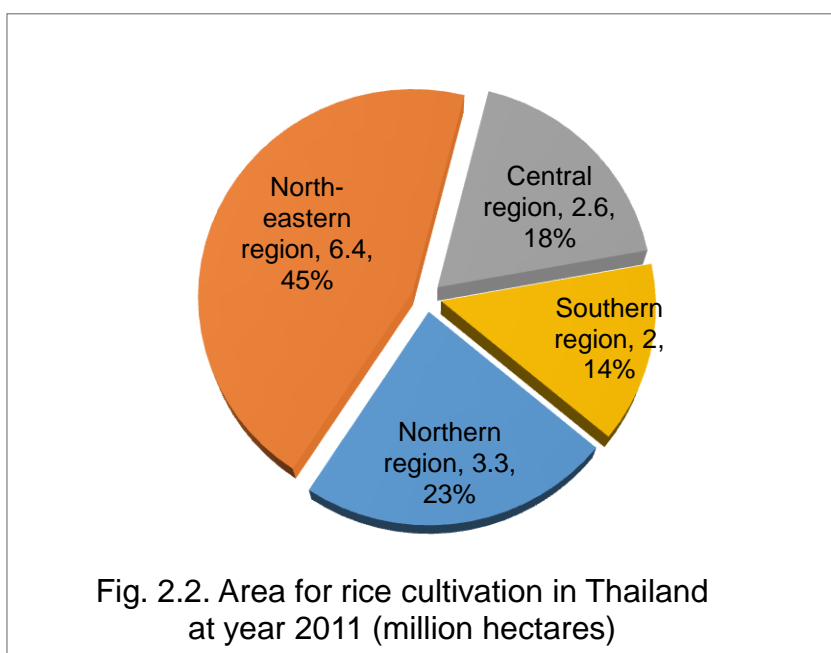

Source: OAE, 2012

The most complete and precise data for soil in paddy fields for the whole of Thailand was done by Kawaguchi and Kyuma (1974;1976). They concluded that OM and SOC was low at 1.05% (app. 22 tons/ha if soil density was assumed at 1.4 g/cm<sup>3</sup> at 0-15 cm depth), similar to that in other tropical countries (1.4%) due to high soil decomposition in this region. Total P was 19 mg/100 g soil (410 kg P/ha). OM and available P were at poor level, related to the results of soil in the majority of Thailand. Available P was only 0.61 mg P/100 g soil (13 kg P/ha).

There is still no precise and updated data set of complete substance stocks in soil from paddy fields in Thailand. Most of them are only either assumed data or data from some specific soil series. Data of C stock in soil was estimated by JGSEE (2012) that the soil from paddy fields should contain 47 tons C/ha at 0-30 cm depth.

The Department of Soil Science, Thailand (2000) estimated that the available N and P in the soil of paddy fields is still deficient, especially in the soil from Northeastern region. Only 0.65% of the total rice cultivating area contain Vertisol soil with medium soil fertility e.g. soil from the Central region (Morakarn *et al*, 2015; Luangta *et al*, 2015). The average data of total Nitrogen in top-layer soil of paddy field from whole of Thailand is not reported. Promnart (2006) estimated that available P in paddy field was approx. 3-7 mg/kg (6.3-15 kg/ha if soil density was assumed at 1.4 g/cm<sup>3</sup>). Wanchai (2013) also reported that available P in soil from Ayuthaya province in Thailand was 20 mg/kg (42 kg/ha at 1.4 g/cm<sup>3</sup> soil density), categorized in a rather high range of available P due to higher soil fertility in this area.

Nutrient deficiency in soil is caused by nutrients uptaken by rice plants in order to build up their tissues and grains. Nitrogen is lost from soil e.g. by volatilization of either Ammonia Nitrogen (NH<sub>3</sub>-N) or Oxide Nitrogen (NO<sub>x</sub>-N). N is also washed out from soil e.g. by rain and surface water, eroded to deeper layer of soil and to the water system.

Meanwhile, the available P in soil is also deficient due to the binding or sorption of P with Cation called "P-fixation". Al ion, a main metal ion in soil actively bound with P at pH approx. 4-6 (Busman *et al*, 2009) - which is the pH range of paddy soil in many areas in Thailand (Multiple Cropping Center-CMU, 2015). Furthermore, as plenty of Fe (II) exists in this intermittently flooded soil, amorphous oxide of Fe (II) is formed as well. This compound has a larger surface area, especially on clay surface. It has therefore a higher sorption capacity than typical soluble Fe(II) crystalline. Immobilized P is then either precipitated as a highly insoluble iron and aluminium phosphates, or adsorbed to the oxide surface, resulting in low available P in soil (Holford and Patrick, 1979). Both mobilized and immobilized P can also be washed out or eroded by water as N. Anurak (2010) reported that substances from soil decomposition, i.e. soluble N and bound phosphate with soil particles were washed out by water run-off from the paddy field. Anyhow, the level of N and P from paddy fields that contaminated into water were still not higher than the legal limits set by the Department of Pollution Control (DPC, Thailand).

For every 1000 kg of paddy grain production, rice plants need 17-18 kg N, 3.0-3.8 kg P. N and P are added in order to compensate for the amount of nutrient loss and to achieve the nutrient levels plants need (Promnart, 2006). Farag *et al* (2013) reported that the average amount of N fertilizer applied for rice cultivation was 285 kg N/ha. Only 30-40% of water-soluble nitrogen from chemical fertilizers can be uptaken by plants before it is eroded away from plant roots to soil's interlayer and fixed with other ions, making Nitrogen unavailable (Rambo, 2015). Ongprasert (2004) suggested farmers to add N from N-chemical fertilizers for 3 times of N that plants still need. At the same time, available P in soil is limited as 95-99% of the total P in soil are present in non-soluble form which cannot be utilized by plants (Wanchai, 2013). 19.5% of P from chemical fertilizers can be uptaken by plants. Therefore, it is recommended to add P from chemical fertilizers for 5 times the available P that plants still need from soil (Rehm *et al*, 2002).

### 2.2.3. Rice cultivation- the source of straw

In general, the farmers in Thailand cultivate the rice twice a year, i.e. major rice cultivation in the rainy season (May to October) and minor rice cultivation in the dry season (November to April), depending on the irrigation capacity in each area (DPC, 2011). 41% of the cultivation area is irrigated, while the remaining areas have no irrigation capacity. Nevertheless, farmers can still cultivate rain-fed rice (DOI, 2009; Premprasit, 2012; Chidthaisong *et al*, 2011). Jasmine rice was the main type used in 2007 (Chidthaisong *et al*, 2011). Farmers increase soil nutrients by collecting cattle's manure, using it as a fertilizer in addition of applying chemical fertilizers (Premprasit, 2012). DPC (2011) reported that the consumption of pesticides and herbicides for rice cultivation is lowest compared to other crop cultivations. Pesticides and herbicides with a long residence time are prohibited. Therefore, the short-life pesticides and herbicides, most of them have life time app. 3-15 days (DPC, 2011), are applied during cultivation if needed. These pesticides and herbicides are mineralized to be non-existing or in the safe level at the end of harvesting (Paipard *et al*, 2014).

Rice field is flooded for the whole cultivation period until 1-2 weeks before harvesting. At this time, the rice stalk above the ground has 140-150 cm height for major rice and 98-120 cm for minor rice (Cheewapongpan *et al* (2011). The root length is 15 cm (Premprasit *et al*, 2012). Harvesting is operated after 90-110 days of cultivation. During the harvesting, farmers cut stalk manually or by machinery over the soil surface, followed by the separation of grains. Cheewapongpan *et al* (2011) reported manual cut of straw at 90 cm above the ground while machinery cut was only 30 cm above the ground. The rice stubble and straw are residues. The ratio of rice straw to rice stubble in the Lower Northern Thailand was 0.96. (Premprasit, 2012).

#### 2.2.4. Rice straw management (RSM) of small farms in the present situation

Rice straw is lignocellulosic residue which can be removed from paddy fields unlike rice stubble. Straw dried weight (DW) contains C 37-52%, O 36-45%, H 4.2-6.3%, N 0.50-0.90%, and P 0.05-0.17%. Straw ash is 13-19% of straw total DW (Kadam *et al*, 2000, Jenkins *et al*, 2003; Koppmann *et al*, 2005; Wanapreecha *et al*, 2008; Oahn *et al*, 2012; Kanokkanjana and Graviat, 2013; Drake *et al*, 2002); IRRI, 2015). Jenkins *et al* (2003) reported that straw ash contained Si 33% as well as other substances e.g. P, K, Cl, Mg, Na, etc. Thailand Research Fund (2007) estimated the annual total production of rice straw in Thailand at 32 million tons/y.

With the different harvesting methods as well as different methods for data collection, result in different ranges of paddy grain straw ratio. Some examples are shown in table 2.1.

Table 2.1. Ratio of rice straw to paddy grain from different studies

Ratio of rice straw to paddy grain	Sources
1.5	Linquist and Sengxua (2005)
1.4	IPCC (2006)
1.35	Kadam <i>et al</i> (2000)
1.0	Devandra (1976, 1980)
0.81	DEDE (2015)
0.69	Kanokkanjana and Gariviat (2013)

Although rice straw can be removed from the field (unlike rice stubble which is burnt or left on the field), farmers still manage the tremendous amount of straw mainly by rice straw open burning (RSOB). Only some portions of the straw are used by farmers, mainly for feeding ruminant livestock or are left over for fertilize the soil (soil incorporation). Utistham *et al* (2007) reported that only 50% of rice straw were taken from the field for straw utilization. The data from DEDE (2003) and Premprasit (2012) showed that only 0.83-11% of total rice straw produced were kept for other agriculture uses as well as for trading to the bale straw traders. Truc (2011) also reported farmers in Mekong Delta used a small percentage of straw for mushroom production.

The main rice straw management in small farms is reviewed in the following paragraphs.

#### 2.2.4.1. Rice Straw Open Burning (RSOB)

Open burning is typically found in tropical regions, especially in Southeast Asia, Africa, and Brazil. Most cases are Anthropogenic burning of forest and agricultural residue in order to prepare the land for next cash-crop cultivation (Koppmann *et al*, 2005). At least 40% of straw are removed from the field by RSOB (Premprasit *et al*, 2012; DEDE; 2003). The burning season in Thailand starts in October to December for burning straw from Major rice harvesting and March to May for straw from minor rice harvesting (Cheewapongpan *et al*, 2011). Premprasit *et al* (2012) reported that Minor rice straw was burned 1.6 times more than major rice residue and most emissions from burning were from straw rather than stubble. In 2009, 26 million tons of straw in Thailand were removed by RSOB (Premprasit *et al*, 2012).

#### 2.2.4.2. Straw as ruminant feedstock

Besides burning, the main use of rice straw in Thailand and Southeast Asia (SEA) is to feed rumen livestock (Truc, 2011). Livestock consumes straw in order to produce the energy for its daily activities and to gain weight (Weiss, 2007). Rice straw is partly collected as the only agricultural residue and used as feedstock in small farms when livestock is fed at home especially during the dry season. In general, ruminant livestock in southeast Asia is raised individually by small farm holders rather than herds, The farmers tether it for grazing in the community areas (Khajarerns, 1984).

#### 2.2.4.3. Straw left over for soil incorporation

Asian farmers incorporate straw into soil after the harvesting of major rice, then leave the field for 8 months until the next cultivating year (in the past when only one harvest per year was common or in the areas which can cultivate rice only once a year) in order to enrich soil with nutrient from degraded straw degraded in soil. Soil incorporation of straw improves soil fertility because this process returns substances in straw back to soil. Towprayoon *et al* (2013) reported that the top layer soil of rice field (0-15 cm depth) accumulated SOC 2.0 tons C/y.ha. They predicted that SOC in Thailand could increase 20 to 60 tons C/ha in 20 years (2011-2030) due to accumulation of organic matters from rice into soil. MOAC (2015) assessed that using straw compost together with chemical fertilizers for long term could increase soil's OM and improve the physical properties of soil as well as increase rice yield by 72-115%.



Soil microorganisms produce their cell and energy from converting organic carbon in straw and in other decomposable matter to metabolic products e.g. CO<sub>2</sub>, CH<sub>4</sub>, and NH<sub>4</sub><sup>+</sup>. Smaller size of straw residue could increase the rate of OM degradation and nutrient absorption by soil microorganisms (Kimura *et al*, 2004). The conversion process by soil microorganisms is slow due to high C:N ratio in straw. Soil microorganisms can degrade straw faster when C:N ratio is around 20-30 by adding low C:N materials, e.g. compost or manure (Ongprasert, 2004). The remaining OM accumulates in soil therefore gradually increasing OM content in soil over years.

Although OM, e.g. straw or manure incorporated in soil increases soil fertility, OM decomposition in soil also emits GHG i.a. CO<sub>2</sub>, CH<sub>4</sub>, and N<sub>2</sub>O. IPCC (2007) reported that rice cultivation contributed more than 10% of total CH<sub>4</sub> emissions at global level. Farag *et al* (2013) found that soil contributed about 53.25% of total GHG emissions from rice cultivation in Egypt. ONREPP Thailand (2010) estimated that CH<sub>4</sub> emissions by rice production in Thailand was 1.4 million tons/y in 2000-2004 and remained relatively stable over years.

CH<sub>4</sub> emissions vary according to climate, location, method of rice cultivation as well as the amount of Root Organic Carbon (ROC), and SOC which enhances CH<sub>4</sub> production (Yuan *et al*, 2012). CH<sub>4</sub> mainly emits from straw decomposition during the early stages of rice cultivation as the soil is under anaerobic conditions from the flooding period (Watanabe *et al*, 1998, Kimura *et al*, 1991). CH<sub>4</sub> is produced anaerobically by methanogen at rhizosphere then mainly emits through the rice stem as well as partly from ebullition and diffusion directly from soil (Towprayoon, 2006). Amendment of chemical fertilizers can inhibit CH<sub>4</sub> Oxidation on the soil surface (Conrad and Rothfuss, 1991). Thus, CH<sub>4</sub> emissions from incorporating OM e.g. stubble, manure, together with chemical fertilizers increase (Vibol and Taoprayoon, 2009; Saenjan *et al*, 2014).

CO<sub>2</sub> is produced from plant respiration during the whole cultivating period. After draining water from the flooded field at the end of cultivation, straw and other OC in soil is further aerobically degraded and converted to CO<sub>2</sub>.

In addition, N<sub>2</sub>O is produced by soil microorganisms via the N cycle. Rubasinghege *et al* (2011) reported that minor amounts of N<sub>2</sub>O can be also converted from either ammonium or nitrate N via an abiotic mechanism in light in combination with humid surface of aerosols or particles in the atmosphere.

## **2.3. Rice Straw Open Burning in Thailand**

### **2.3.1. Identification and quantification of straw burning area**

Data of burning areas vary according to the methods for data collection e.g. interviewing, questionnaire, field surveying, or satellite imagery. The problem of interviewing and questionnaires with farmers is data reliability. As RSOB is now illegal in Thailand, satellite imagery is an alternative method to detect fire spots of open burning, e.g. the study on biomass burning in tropical America (Hao and Liu, 1994), the fire hot spot (FHS) detected by Moderate resolution Imaging Spectroradiometer (MODIS) sensor from BlueSky Frame work developed by US Forest Service (USFS) (Choi *et al*, 2013) and from LANDSAT5 (Choenchooklin *et al*, 2010), or the hot spots provided by NASA's Earth Observatory Website (Tippayarom, 2012). FORMOSAT-2 satellite image was also used in a study of Chang *et al* (2013) and Liu *et al* (2013) to detect straw burning areas in Taiwan.

From the questionnaire in the detected hot spot areas in 2007-2008, Cheewaphongphan *et al* (2011) found that burning areas were 30-69% of total areas and emitted annually 27 Megatons CO<sub>2</sub>e from 22 Megatons rice residue. Premprasit *et al* (2012) reported from his questionnaire in 2009 that 7.9 million Ha of paddy fields were burnt, equalling 69% of the total cultivated area.

Based on calculations of burning areas from hot spot and field experiments, Choenchooklin *et al* (2010) reported that the burning areas in the Lower north of Thailand in 2010 were 50-57% of total cultivating area and emitted CO<sub>2</sub> 3.7 tons/ha. Pollutant emissions calculated from satellite imageries by Towprayoon (2007) were 79 million kilograms CO, and 8.7 million kilograms PM from rice straw and stubble burning in Thailand in 2002, i.e. more than those in Cambodia, Vietnam, and Lao PDR. The peak period for RSOB in Thailand, Lao PDR, and Cambodia is from January to April, similar to the that in Indochina (January-March) according to Gariviat *et al* (2007).

### **2.3.2. Characteristics of air pollutants from RSOB**

The pollutant emissions from RSOB can be either evaluated directly from experiments or calculated from default values of emission factors. RSOB is an incomplete combustion process. The air pollutants emitted from RSOB are composed of CO<sub>2</sub> 70-97%, CO 7-11.3% (Cofer *et al*, 1998 in Koppman *et al*, 2005; Choenchooklin *et al*, 2010; Chang *et al*, 2013; Singh *et al*, 2004), as well as other gases and aerosols e.g. CH<sub>4</sub>, NO<sub>x</sub>, N<sub>2</sub>O, NMHC (None-methane hydrocarbon), and PM (Koppman *et al*, 2005). In general, 90% of C in straw were burned then oxidized to CO<sub>2</sub> and CO while less than 5% of total C was contained in PM (Oanh *et al*, 2011).

The example of air pollutants from RSOB in Thailand is shown in Table 2.2.

Table 2.2. Pollutant emissions from RSOB in Thailand

Type of pollutants	Emission Factor (EF, g/kg DM)	Amount of Emission (Gg)
CO <sub>2</sub>	1500	12000
CO	35	290
CH <sub>4</sub>	1.2	10
N <sub>2</sub> O	0.07	1
NO <sub>2</sub>	3.10	25
SO <sub>2</sub>	2.0	16
Total Particulate Matter (TPM)	13	106
NMHC	4.0	32

Source: Gadde *et al* (2009)

PM is a particles mixture of soot, ash, fumes, volatile organic Carbon (VOC), Polycyclic aromatic hydrocarbon or PAHs (Jenkins *et al*, 1998), metal ions as well as oxidized ions e.g. NO<sub>3</sub><sup>-</sup>, NH<sub>4</sub><sup>+</sup>(Herrera *et al*, 2009). It is the particles part of aerosols containing mainly organic C and partly black C (Reid *et al*, 2005). Oanh *et al* (2012) reported RSOB in Thailand emitted PM<sub>2.5</sub> containing 393 mg total C/g PM and PM<sub>10</sub> containing 385 mg total C/g PM. Both of them contained significant amounts of OC, water soluble ion, Levoglucosan, including relatively high amounts of methoxyphenol, PAHs, as also reported by Shen *et al* (2011). PM may also contain pesticides from contaminated straw. Organic pollutants e.g. NMHC, PAHs especially dioxin, are possibly emitted in the gas phase, or as constituents of the PM (Oanh *et al*, 2011; Sanchis *et al*, 2014).

Amounts and varieties of pollutants from RSOB are influenced by the composition and moisture content of burning materials as well as the burning temperature. Sanchis *et al* (2014) reported that the emission of 690-840 kg CO<sub>2</sub>/dry straw varied between 10-20% according to the moisture content. They also found that burning straw with a higher moisture content increased the emissions of PM, Dioxin, PAHs as well as burning time. In their experiment, CH<sub>4</sub>, Aldehyde, aromatic compounds emitted at a burning temperature of 200-250°C. Oanh *et al* (2012) also reported that pile burning emitted a higher level of pollutants than spread burning.

### 2.3.3. Impacts of rice straw open burning (RSOB)

#### 2.3.3.1. Impacts at farm level

During burning, the plant nutrients, typically more than 90-100% of C, 80-100% of N, 24-25% of P are lost to the atmosphere (Heard *et al*, 2006; Singh *et al*, 2008; Jain *et al*, 2014). RSOB therefore results in nutrient depletion in soil (Promnat, 2006). It was also reported that the loss of C, N, and P from RSOB in Panjab/India during 2008-2009 was equivalent to 2400 kg C/y.ha, 35 kg N/y.ha, and 3.2 kg P/y.ha. (Singh *et al*, 2008).

P is a critical nutrient affected by RSOB because it can be carried by a distance before depositing back to soil and water system. Anderson *et al* (2010) reported that P emissions are mainly composed in different phases in dust and PM. Only 17% of P emitted from burning were water soluble and can become bioavailable for living organisms, resulting in lower rice productivity. Ponnaperuma (1984) reported that productivity from rice cultivation with RSOB practice (3.4 tons paddy grain/ha) was lower than without RSOB (4.1 tons paddy grain/ha). Because of this effect, farmers need to use more fertilizers, causing higher investment for their rice cultivation as well as fertilizer contamination of the water resource.

#### 2.3.3.2. Impacts at regional level

##### 2.3.3.2.1. Direct impacts of pollutant dispersions

The air pollutants from RSOB can be carried away from the burning location by wind. The atmospheric residence time of each pollutant is different. The pollutant having a longer residence time can disperse further. For example, CO has an atmospheric residence time of approx. 2 months (Wang and Prinn, 1998). Hence, CO can be widely distributed and transported over a long distance into the troposphere. CO is therefore used as an indicator to trace biomass burning (Koppmann *et al*, 2005). NO<sub>x</sub> can last in the atmosphere only for hours or days while PM is dispersed by wind to the lower troposphere in 1-2 weeks (Jacob, 1999; US-OAQS, 1995).

CO carried by wind from Southeast Asia can be transported to Western South Pacific (Matsueda *et al*, 1999). The particles from RSOB in Thailand are carried by west and southwest Monsoon-winds during the wet season. They travel over the 2-4 km high mountains in Lao PDR, Vietnam, and further to the Pacific Ocean and beyond (Reid *et al*, 2013). The precipitation of the particles is low in the dry season due to weaker winds from the North-east (China). At the same time, high mountain ranges in the north and west of Thailand delay or block particle translocation by wind out of the valleys of Thailand, Burma/Myanmar and Cambodia (Reid *et al*, 2013). Therefore, they have a longer residence time in the atmosphere, resulting in Haze problems in the region. Sillapapiromsuk *et al* (2013) reported that PM<sub>10</sub> from open burning in Chiang Mai were 3051 tons in 2010 and 705 tons in 2011. 2-5% of total PM<sub>10</sub> emitted from burning in rice field areas. Thipayarom and Oanh (2007) found that the PM<sub>10</sub> level in the central region was highest in March.

PM<sub>10</sub> was translocated from 12 hours to many days from its source in the west of Bangkok to Bangkok City, depending on wind speed and season. Anyhow, the PM<sub>10</sub> emissions (88 µg/m<sup>3</sup>) in their experiment did not reach the maximum limit of air quality standards due to the geographical advantages of that area, unlike the mountain areas in Northern Thailand.

The other relevant effect of the dispersion into the atmosphere is the reduction of solar radiation. The combination of black carbon (BC) particle in aerosols and clouds can reduce solar radiation to the earth surface (IPCC, 2007), causing problems of visibility. Furthermore, the hydrophobic particles from aerosol e.g. BC, OC also delay the growth of cloud condensation nuclei, inhibit the buildup of water vapor pressure in the nucleating droplet, hence only non-precipitation clouds are formed, delaying rain fall (Jacobson *et al*, 2000; Fowler *et al*, 2011; CU, 2005).

PM have the most crucial effect on the human health among all pollutant dispersions via RSOB in Thailand. PM of less than 10 µm can penetrate deep into the lung (Oanh, 2012; Tripathi *et al*, 2013). CO is also hazardous as it competitively binds with Hemoglobin reducing its capacity for oxygen transportation. These health problems are already mentioned in Chapter 1.

#### 2.3.3.2.2. Direct impacts of pollutant depositions

Pollutants' deposition happen mainly with the atmospheric short residence time of pollutants e.g. NO<sub>x</sub>, PM. Kim and Betram (2014) found that 15% of NO<sub>x</sub> from the shore was taken to the sea overnight to form Nitryl Chloride.

There is no clear data about PM deposition. IPCC (2007) estimated that 30% of the particles emitted in Asia deposited in the deserts and 20% were carried over the region while 50% were transported to the Pacific Ocean and beyond. The meteorological parameters e.g. rain, wind, influence its deposition. In the rainy season, short residence time pollutants are deposited from the atmosphere faster (Singh, 2010).

Wet deposition of NO<sub>x</sub>-N and NH<sub>3</sub>-N from the atmosphere, e.g. by rain, is affecting the carbon cycle through increased nutrient supply at the depositing location. Their precipitation increase the acidity of rainfall hence affecting terrestrial and aquatic environment. These pollutants combined with the climate conditions e.g. rain, wind direction, as well as geographic condition cause environmental problems in that region. It is estimated that N deposition rates over Asia are likely to increase 1.4 to 2 times by 2030 (IPCC, 2007)

#### 2.3.3.2.3. Indirect impact of pollutant depositions

The losses of soil nutrients are remedied by using chemical fertilizers on agricultural soil. However, the overusing of chemical fertilizers leached into the water system causes water pollution. Too high amounts of substances from fertilizers leaching into water e.g. NH<sub>3</sub>-N, PO<sub>4</sub><sup>3-</sup> induce overgrowth of microorganisms, algae, and aquatic plants which leads to the depletion of dissolved oxygen and increases the risk of eutrophication (UNESCO, 1982).

### 2.3.3.3. Impact at global level

The biggest amounts of air pollutants emitted from RSOB are GHG, i.e. CO<sub>2</sub>, CH<sub>4</sub>, and N<sub>2</sub>O. Gadde *et al* (2009) reported that RSOB in Thailand caused 0.18% of total country GHG emissions. CO<sub>2</sub> has a longer life time but cannot be defined precisely, as CO<sub>2</sub> can be turned over from the atmosphere by photosynthesis via terrestrial and aquatic plants, as well as by phototrophic microorganisms in the hydrosphere. It can also react with water at the ocean surface by forming Bicarbonate and Carbonate ions. Otherwise, CO<sub>2</sub> might remain in the atmosphere for decades or centuries (IPCC, 2007). CH<sub>4</sub> can remain in the atmosphere for 12 years before being mainly transformed by chemical oxidation in the troposphere to CO. The sink CH<sub>4</sub> is the reaction with OH<sup>-</sup> radical in the atmosphere. This reaction is controlled by the complex reaction of CO and NO<sub>x</sub> in the troposphere (Jain *et al*, 2004). N<sub>2</sub>O remains in the atmosphere for approximately 114 years before moving into the stratosphere as N<sub>2</sub> and O (IPCC, 2007). Less than 5% of N<sub>2</sub>O are converted to NO which depletes Ozone (Jacob, 2004). Not only do GHG have the capacity to absorb heat energy, they also have a long residence time in the atmosphere, as shown in table 2.3. Therefore, they strongly contribute to global warming.

Table 2.3. Life-time and Global Warming Potential (GWP) of GHG from RSOB

GHG	Atmospheric life time	GWP (100 years)
CO <sub>2</sub>	30-95 years or more	1
CH <sub>4</sub>	12 years	21
N <sub>2</sub> O	114 years	310

source: IPCC (2007), Jacobson (2005)

IPCC (1996) reported that CO is the only atmospheric source of CO<sub>2</sub>, approx. 20% of total CO<sub>2</sub> in the atmosphere. CO can convert to CO<sub>2</sub> a reaction with OH<sup>-</sup> in the troposphere. Wang and Prinn (1998) predicted from mathematic modeling that the percentage of CO<sub>2</sub> from CO should be less than 10% by the end of year 2100 due to higher proportion of CO<sub>2</sub> input into the atmosphere. As the atmosphere is the major sink of CO via oxidation with at least 50% atmospheric OH<sup>-</sup> (Collin *et al*, 1997), increasing of CO reduces OH<sup>-</sup> (Wang and Prinn, 1998) affecting the gases which need the OH<sup>-</sup> radical for their conversion, e.g. CH<sub>4</sub>, O<sub>3</sub>, NO<sub>x</sub> (US-EPA, 2000).

PM has a certain mitigating effect on global warming. Jacobson *et al* (2004) concluded that these particles cooled down climate temperature, however only for a short time while GHG, on the contrary, increase climate temperature for many decades.

## **2.4. Possible technologies for utilizations of straw and RSM residues in small farms**

With all impacts mentioned above, improving straw management in small farms would be an effective approach. Furthermore, Kadam *et al* (2000) suggested to motivate farmers with the prospect of economic profits and time efficiency to implement possible solutions.

Owing to the lack of knowledge of the farmers, suitable technologies should be simple as well as less labour, and low cost, combined with an efficient storage system like baling which reduces the storage space needed and also allows farmers to easily move the bales of straw for storage or for trade. Bale straw prices in Thailand fluctuate depending on market demand. Chinawerooch *et al* (2014) reported that baling increases straw price to 66 USD/tons, making it 11 times more valuable than traded unbaled straw; Kannokanchana and Gariviat (2013) reported that its price was even as high as 67-150 USD/tons in 2010.

Some potential technologies for utilizing straw and its residues in small farms are described below.

### **2.4.1. Straw for mushroom production**

Mushroom cultivation is a value-added process to produce a valuable product for the market from agricultural waste by mushroom degradation (Akinyele and Adetuyi, 2005). Paddy Straw Mushroom (*Volvariella volacea*) is one of the most cultivated mushrooms due to its pleasant flavour and taste (Thiribhuvanamala *et al*, 2012). Its production amounts to 5-6% of global mushroom cultivation (Buswell and Chen, 2005). Rice straw is a natural habitat of this mushroom in tropical and subtropical countries (Stamets and Chilton, 1985). Unlike other mushrooms which need sophisticated cultivation, e.g. in a mushroom house with sterilized nutrients for mushroom inoculum, the cultivation of straw mushroom is simple. It can be done by straw bed method or in a mushroom house at industrial scale with a Biological Efficiency (B.E.) of 8-15%, depending on the quality of the substrate and method used (Biswas and Layak, 2014). Producing straw mushroom would increase food security for farmers in low-income countries and can be an supplementary income for those in emerging economies due to high demand on the domestic and international markets. Mushroom emit low CH<sub>4</sub> compared to rapidly composing and incorporating straw to soil (Truc *et al*, 2014).

Mushrooms are aerobic microorganisms and contain 90% moisture content in its tissue. The Respiratory Quotient of straw mushroom (using carbohydrate from cellulose and hemicellulose containing substrates) is between 0.7-0.93 (Hou and Wu, 1972). Its metabolism is high during 14 days of cultivation until it reaches its egg stage which is the time for harvesting (Bechara, 2007; Chang and Quimo, 1989). The size of mushroom spawn fresh weight (FW) for each cultivation is app. 2-5% of its substrate (Stamets and Chilton, 1984; Lardmahalab, 2010). As the alternative, smaller size of this inoculum takes a longer cultivation period to reach its maximum cell density. Thus, it might not

be able to compete with any contaminant microorganism growing faster, resulting in cultivation failure. In Thailand, the farmers use 1/3 to 1 bag of 500-600g spawn bag for 1 basket containing 5 kg straw (Lardmahalab, 2010). Mushroom only needs few portions of starch (Rennan *et al*, 2008) in order to be used as initial substrate to activate initial growth before it can start degrading the cellulose component in straw substrate. N source should be enough for mushroom uptake in order to build up its protein. Any costless OM with high N, e.g. manure, chopped street and aquatic plants, can be used as a N source for the mushroom in a low cost production, e.g. basket cultivation (OAE, 2015).

The high amounts of nutrients and extracellular enzymes secreted from the mushrooms which remain in the Spent Mushroom Substrate (SMS) make this residue valuable. SMS composition varies and depends on the substrate's composition and the mushroom type's ability to consume and degrade nutrients in its substrate. Protein N, and C:N ratio in SMS increase from mushroom hypha and other OM from cultivation, comparing to original straw, e.g. SMS from *Agaricus* Cultivation contains a C:N ratio of 13:1 (Jordan *et al*, 2008). Its texture and nutrients can improve soil fertility. Pennsylvania State categorized SMS as fertilizer and soil amendment (Fidanza *et al*, 2010).

Extracellular enzymes excreted from mushrooms as well as crude protein in SMS cause high in vitro digestibility resulting in a potential N source for poultry and animal feedstock (Zhang *et al*, 1995). Most studies are about feeding by *Agaricus* and *Pleutorus*. Fazaeli and Masoodi (2006) found that SMS of *Agaricus* mushroom provided considerable amounts of crude protein for feeding ruminant animals. However, high ash content in SMS depletes its available minerals and reduces the voluntary intake by rumen animal (Phan and Sabaratnam, 2012) as well as the animal's daily weight gain. For example, Fazaeli and Masoodi (2006) reported that voluntary intake by sheep was significantly reduced when it was fed by 30% SMS instead of only 10 to 20% of its diet. By contrast, Oh *et al* (2010) reported that *Pleutorus*'s SMS could replace 40% of rice straw for the diet of Hanwoo Steers without negative effect. Katya *et al* (2014) recently found that SMS from *Pleurotus* can be used at 6.3% of the total fish meal to feed juvenile Amur catfish without negative effect. The studies on SMS as feedstock are still ongoing.

#### 2.4.2. Straw as a main animal feedstock

Rice straw contains high C, it is therefore a potential energy source for ruminant livestock. As straw contains complex lignified structures in the cell walls as well as low N, its quality needs to be improved before using as a main feedstock. N from non-protein Nitrogen, e.g. NH<sub>3</sub>, urea, are added to solubilize the straw's cell walls resulting in increased straw digestibility, as rumen microorganisms anabolize protein from non-protein N sources during digestion (Trach *et al*, 2001; FAO, 2001). "Ammonia treatment" is hazardous, the method is complicated and NH<sub>3</sub> loss via volatilization is very high. In



Denmark, N volatilization from  $\text{NH}_3$  treatment was 4.5% of total N volatilization from agriculture in 1996 and 2.3% in 2003 (NERI and DIAS, 2001). Using urea approx. 4-6% of total straw for "Urea treatment" can effectively solubilize cell walls. Urea treatment needs 30% moisture content in straw, thus risking mold contamination during the storage of treated straw (Chenost and Kayouli, 1997). Furthermore, 4-6% is too high for rumen bacteria efficiently utilize, resulting in the remaining of unused N in livestock's manure. "NaOH treatment" is an extreme method as NaOH is a strong base. Technically, this chemical is hazardous, complicated to handle, and too expensive for small farms (Owen *et al*, 1984). Using CaO or  $\text{Ca}(\text{OH})_2$  as single chemical for a "Lime treatment" is quite ineffective as lime is not water-soluble enough. Farmers would therefore need to use large amounts to maintain the alkalinity effect of straw treatment (Zaman *et al*, 1994).

Using Lime and Urea combined as "U-lime treatment" is an alternative method for straw treatment as it is inexpensive and available (Owen *et al* 1984).  $\text{NH}_3$  slowly released from ureolysis can disperse and solubilize straw's cell wall together with lime. Adding N from urea also increases nutritional values of straw. At the same time, the alkalinity of  $\text{NH}_4\text{OH}$  from the reaction of both chemicals is also strong enough to prevent mold growth (Trach *et al*, 2001). Calcium from lime remaining in treated straw also acts as a supplement nutrient for animal and has no hazardous effect on the environment (Chaudhry, 1998a; Nath *et al*, 1969). Trach *et al* (2001) suggested combining 3% lime together with 2% Urea in order to avoid overusing lime as well as minimizing the loss of  $\text{NH}_3$  from urea during the storage (Trach *et al*, 2001; Zaman *et al*, 1994; Jayasuryia and Perera, 1982).

#### 2.4.3. Straw for construction material

Straw has been used world-wide as construction material. In rural areas, farmers also use straw as a roofing material. Nowadays, baled straw is used as a building block for straw houses while loose straw is mixed with cement and sand to produce mortar for building walls and producing bricks (Phyper, 2014). Other uses include are particle board composites from mixtures of rice straw and wood subjected to a high temperature and pressure process (Russell and Johnson, 1996; Zheng Chang, 2015).

Light weight brick is an example of construction material produced by a simple process with unsophisticated machines as that for particle board. It can be produced by template, semi-mechanized machine, or more sophisticated machinery (Allam *et al*, 2011; Kamwangpreuk, 2011). It is therefore possible to produce light-weight brick at farm or community level. For effective use, the quality of straw brick should reach existing standards e.g. the Thai Industrial Standard for community Light-Weight Concrete Element with a minimum stress of 2.5 MPa for filler brick and 7.0 MPa for load bearing walls (TISI, 2004). Allam *et al* (2011) found that 40 kg straw with 3010 kg of Portland cement result in a strong light weight density 1.7 kg/dm<sup>3</sup> at a maximum stress of 120 kg/cm<sup>2</sup> (12 MPa) and no significant loss of strength at 300 °C fire.

Straw brick has excellent properties for trapping C emitted from straw due to the slow degradation of dry straw because of low contents of N, O<sub>2</sub>, and especially few moisture in the brick. Summer *et al* (2003) reported that only 3%/year of the weight of straw with a moisture content below 39% DW was lost by microbial degradation.

#### 2.4.4. Straw and RSM residues for producing alternative energy

##### 2.4.4.1. Solid fuel and liquid fuel

Liu *et al* (2011) report that rice straw in China contained 10-20% of moisture and an energy value of 18 MJ/kg at a 50-120 kg/m<sup>3</sup> bulk density compared to green coal and brown coal (600-900 kg/m<sup>3</sup>). Although its high volatile matter (up to 85% DM) helps straw to be ignited easily, its low density increases complications for processing, storage, and firing. Its combustion is rapid and difficult to control compared to coal (Liu *et al*, 2011). Straw must be pressed to pellets or briquette by machines in order to be used as solid fuel. Jenkins *et al* (1998) reported that rice straw emitted NO<sub>x</sub> 0.40% and SO<sub>2</sub> 0.035% of dry fuel in the combustor, i.e. more than wood. The ash of Rice straw has a high amount of SiO<sub>2</sub> and also contains Na, K, Cl (Liu *et al*, 2011). These substances cause fouling, slagging, and corrosion by alkali in the machine (Zarfar, 2015). K also deactivates the catalytic reduction of NO<sub>2</sub>, hence reduces the quality of fly ash from the combustion process of straw and coal in power plants (Jenkins *et al*, 1998; Jensen *et al*, 2001). Therefore, it cannot replace coal combustion in commercial/or industrial combustion engines without proper design and operation. Thananont (2014) reported that electricity production from straw in Thailand is still not accepted by the local communities. Thermal conversions e.g. pyrolysis, gasification should handled by professionals due to high ash, tar and emission of hazardous pollutants i.a. CO (Pottmaier *et al*, 2013; DEDE, 2014).

Another alternative energy is bioethanol. A study of Silalertruksa and Gheewala (2013) concluded that the bio-ethanol pathway resulted in highest environmental sustainability compared to using straw for either direct combustion or thermo-chemical conversion to bio-Dimethylether (DME) as it reduces global warming and resource depletion. However, Bioethanol is effectively produced only at industrial scale as it needs knowledge and costs to chemically or enzymatically convert cellulose.

##### 2.4.4.2. Biogas

Biogas is a potential energy source that can be produced at the level of small farms as the organic materials needed for producing biogas in an anaerobic digester, e.g. agricultural wastes and animal wastes, are readily available. It is as sustainable as bioethanol (Silalertruksa and Gheewala, 2013). Digester slurry, the residue after anaerobic digestion, also contains high nutrients for plants (Wilke, 2013). Furthermore, it is defined as a clean fuel thanks to combustion without smoke. Capacity for using biogas at household level is concluded in Table 2.4.

Table 2.4. Consumption of biogas for different activities and compared to other fuels.

Energy consumption	amount of biogas consumed
cooking for 1 person 1 meal	150-300 litres
1 litre water boiling	30-40 litres
1 day of a 25-75 W lighting	120-150 litres
1 kWh electricity	1 m <sup>3</sup>
0.46 kg LPG or 0.6 l. Diesel or 1.5 kg fire wood	1 m <sup>3</sup> or 1.15 kg

Source : Kossmann *et al* (1997)

Biogas can replace LPG, hence reduce LPG consumption as the main cost for household (HH) cooking in 2011 (NSO, 2011). Onwongsa (2012) reported that 21.5% of LPG consumption in 2011 were imported, increasing at a rate of 7% per year. 38% of LPG consumption was used for household consumption (220 kilotons/month). Seeing the potential of clean energy and waste reduction, the Thai government subsidized construction costs of biogas units at small and medium animal farms from 1999-2003 (EPPO, 2003).

Under anaerobic condition, carbonaceous molecules in the substrates are hydrolyzed by hydrolytic bacteria, then converted to acetic acid by acidogenic bacteria. Methanogen then converts those C intermediate products mainly to CH<sub>4</sub> and CO<sub>2</sub> in approx. 21 days. The digester slurry, the residue from fermentation, consists of refractory organics, new microbial cells, including ash (Marchaim, 1992; Gupta *et al*, 2012). All germs and seeds in the digester slurry are killed (NEPO, 2000). The proportion of NH<sub>3</sub>-N in the slurry is also increased from around 33% of total N to 80% (Joergensen *et al*, 2009). Furthermore, its C:N ratio is 15-20, suitable and sanitized to be used as a plant fertilizer, soil conditioner, compost, N-source for mushroom production and for supplementary fish feeding (Marchaim, 1992; Kossman *et al*, 1997). N effectiveness is reduced from 100% in the fresh slurry to 85% in the dry slurry due to losses from N volatilization (Marchaim, 1992).

Biogas from agricultural waste has a density of approx. 1.2 kg/m<sup>3</sup> and contains CH<sub>4</sub> 60-75%, CO<sub>2</sub> 19-33%, N<sub>2</sub> 0-1%, H<sub>2</sub>O 6%, including trace amounts of other gases e.g. O<sub>2</sub>, H<sub>2</sub>S (FAO, 1996). Various types of simple and low-cost digestors are suitable for producing biogas in small farms e.g. fixed-dome, floating drum, PVC digester developed from tube digester "Taiwan model", as well as 200 litres small tank digestors for HH level (Kossman *et al*, 1997; DEDE, 2015). Recycling of fresh slurry helps the fluid flow into the plug-flow digester (Usack *et al*, 2014). Biogas yield from cattle manure is 0.2-0.3 m<sup>3</sup>/kg of Volatile Solid (Jørgensen, 2009; Steffen *et al*, 1998).

Although straw contains high C, the perfect C-source for biogas production, lignin in cell wall structure, rigid texture and rough size are the main problems for mixing it and cause lower biogas yield. Pretreatment processes like mechanical e.g. grinding, thermal e.g. steaming, and biological e.g. enzymatic conversion, improve straw fermentation in the digester. The principles of pretreatment are i) to increase the surface for enzymatic reaction ii) to reduce the barrier e.g. lignin, for enzymes to attach to the substrate surface iii) to degrade cellulose and hemicellulose from straw for accelerating the fermentation process iv) to improve homogeneity of substrate slurry for ease of mixing (Garrote *et al.*, 1999; Knappert *et al.*, 1981; Montgomery and Bochmann, 2014).

Furthermore, straw has C:N ratio higher than 40. Co-digestion with other low C:N ratio substrates can improve the performance of biogas production. At the same time, increasing of bacteria inoculum also helps to increase the number of microbial cells to speed up the fermentation rate. Gupta *et al* (2013) reported that biogas yield of pretreated straw in the co-digestion of straw-cow manure for 30 days was 39% higher than from untreated straw.

However, the effective pretreatments mentioned above are costly and need knowable handling, suitable only for industrial scale. In small farms, cattle digestion works best as pre-treatment and is even cost-free.

#### 2.4.5. straw and RSM residues for aquaculture

Aquaculture for fish production in small farms is a method to reduce residues from farms e.g. straw, manure, etc., by converting them into fish protein, the main component of the fish body (Ahmed *et al*, 2010 ). This method improves farm economics either via direct income from selling the fish or as an alternative protein source for the HH. The fish produced on small farms should need less care and respond to market demand, e.g. Tilapia.

##### 2.4.5.1. Preparing fish feed

The traditional method to produce fish feed for Tilapia culture in Thailand is for farmers to soak straw with or without manure at the corner of the fishpond. This softens straw, allows nutrients from straw and manure to be slowly released and degraded, and grows algae in the pond feeding the fish (Chinapong, 2014). DOF Thailand (2015) recommended to add either 9 kg of manure or other plant residues from farm in a 50 m<sup>2</sup> pond every month for the first 6 months of cultivation, after which it should be reduced to half or instead using 3 kg of dried manure together with rice straw. Some farmers found that overusing straw into fishponds increases plenty of mud and sediments, originated potentially from which might be from high content of ash (OAE, 2014).

The other potential feeds from residue are SMS as well as digester slurry. Dong *et al* (1995) reported that SMS containing 39.8% protein with 1.76% lysine and 3.82% alanine increased bream net fish production by 6.31%. The problem of using high  $\text{NH}_3\text{-N}$  substrate e.g. manure and slurry from biogas digestion directly into the fishpond is oxygen reduction due to eutrophication. Furthermore, high  $\text{NH}_3\text{-N}$  in slurry might be toxic for the fish. As many aquatic plants are suitable for N and P absorption reducing the effects above, farmers can cultivate them for trapping  $\text{NH}_3\text{-N}$  and P from wastes and subsequently use them as alternative fish feed.

Duckweeds (Lemnaceae) are small floating plants forming mat-like over the water surface. It can utilize N from nutrient-rich water e.g.  $\text{NH}_3\text{-N}$  and convert it to protein. Duckweed protein is 15-45% of DM depending on the amount of N in the water (Ansal *et al*, 2010). Duckweed can grow properly in the pond using slurry from biogas digester (Rodríguez and Preston, 1996), and even contains higher crude protein than cultivated with manure (Chau, 1998). Duckweeds are therefore considered as a potential N remediator and nutrient sink in the tropical region. Ansal *et al* (2010) and Zimmo (2003) reported that duckweeds removed N 26-33% of total N existing in ponds at pH 5-7 and N 38-41% at pH 7-9. Their doubling time is 1-2 days and they can grow in a 0.2-1 m deep pond without any need for chemicals, e.g. herbicides, pesticides or fertilizers (Skilicom *et al*, 1993; Chau, 1998). After reaching 1  $\text{kg/m}^2$ , duckweeds can be harvested daily (Skilicorn *et al*, 1993). As Duckweeds contain high protein and is easy to harvest unlike algae, they can be used as N-source for feeding fish and animals or for cultivating mushrooms.

#### 2.4.5.2. Fish production

Referring to the criteria for fish production above, Tilapia (*Oreochromis* spp.) is a suitable fish for small farms. 95% of total Tilapia production of 2012 in Thailand was only for the domestic market (OAE, 2013). Tilapia is easily handled by farmers because of its tolerance to changes in cultivating conditions from 8-42 °C and pH 6-9 (McGee, 2010).

Tilapia has a moisture content of approx. 77-79 % and contains protein 10-19% DW (Biro, 2013; Santos *et al*, 2012). Its body composition remain unchanged in different stages (Chowhury and Bureau, 2009). Tilapia is herbivore and occasionally omnivore. It can be fed by various fish meals as well as algae and plants like duckweeds. 500 kg FW/fish should be gained in 12 month (DOF, 2015). Cultivating tilapia can be very basic with 1-3 fish/ $\text{m}^2$  of a 1 m-deep pond's surface area but it can also be cultivated at higher density which however needs more attention and intensive feeding and handling. Tilapia can be cultivated as either monoculture or polyculture together with e.g. *Pangasius*. The critical factor for tilapia cultivation is the  $\text{NH}_3\text{-N}$  concentration due to possible negative effects on fish health (Godkin *et al*, 2015). The Nitrite and  $\text{NH}_3\text{-N}$  levels in the pond should not be higher than 5 and 0.20 mg/l, respectively (Rakocy, 1989; Popma and Masser, 1999). Abdella (1990) found that  $\text{NH}_3\text{-N}$  at 0.8-0.9 ppm reduced fish growth by 50%. Protein content in fish increases with higher protein in fish feed (Ahmed *et al*,

2010; Godkin *et al*, 2015). Mueller and Bauer (1996) found that every 1 kg of total protein input in the pond was converted to 0.21 kg fish protein in its tissue N in fish is also from. N input in pond can be also from N fixation by N-fixing algae in the pond but the ratio varies and depends on N concentration in pond. Eгна and Boyd (1997) reported that the ratio of N consumed by fish from manure: from the N fixation was changed from 1:3.8 (at 2500 kg manure/ha in 5 months) to 43:1 (at 20000 kg manure/ha in 5 months). However, the precise nutrient balance of this phenomenon is still unclear.

#### 2.4.6. RSM Residues as soil fertilizers

SMS from mushroom production, manure from livestock production, digester slurry from biogas production, as well as effluent from duckweed and fishpond can be used as soil fertilizer thanks to a suitable C:N ratio approx. 20:1 to 35:1, similar range of C:N in soil microorganisms of approx. 30:1. Too high C will induce temporary N limitation in soil and slow down microbial growth rate and organic mineralization while too low C will limit microbial respiration due to lack of energy sources from Carbon (Ongprasert, 2004; Promnat, 2006 ).

Adding of OM together with chemical fertilizers can improve soil fertility and leads to higher productivity. Intrawech and Imsompooch (2011) reported that soil fertility in an area in Northeastern Thailand was improved by this combination. OM of this soil at 0-30 cm depth was gradually increased. Likewise, its available P increased from 5.5 mg/kg or app. 23 kg/ha (low) to 9.6 mg/kg (rather low) or 40 kg/ha (if soil density is assumed to be 1.4 g/cm<sup>3</sup>). Keophila *et al* (2013) found that soil density of paddy fields in an area in Northeastern Thailand was reduced from 1.5 g/cm<sup>3</sup> to 1.2-1.3 g/cm<sup>3</sup> after incorporating soil with the left over straw for 8 months together with the adding of chemical fertilizers. This combination increased the rice yield e.g. from 1.8 tons/ha to 2.8-4.9 tons/ha in Khon Kaen Province (Keophila *et al*, 2013) and from 1.2 tons/y.ha in year 1986 to 3.0 tons/y.ha in year 2000 in Toong Kula Rong Hai area of Northeastern Thailand (DLD data reported by Intrawech and Imsompooch, 2011). N and P from OM degradation are slowly released and uptaken on time by plants before being leached away by water or trapped by ion in soil. Organic N in soil is mineralized at approx. 60-70%. This amount is ready to be uptaken by plants in the first few years. P efficiency for plant uptake from OM e.g. from manure is about 60-70% compared to approx. 20% from chemical fertilizers (Shiga, 1997). 60-80% of the total P in manure is already available for plants within 1 year, compared to 20-38% of available P from chemical fertilizers (Rehm *et al*, 2002).

In 2010, DLD promoted organic fertilizers in order to increase OM and reduce chemical fertilizers used by farmers (Banmeung, 2010). Therefore, the trend of using organic fertilizers in Thailand has increased

## **Chapter 3**

### **Methodology**

#### **3.1. Definition of an exemplary small-scale Thai farm system**

The descriptions of the farmer's farm management and of his household are collected from available statistics and literature reviews as well as by personal interviews of 50 farmer households (HH), the data of which can be used only as auxiliary data as the farmer's interviews were not consistent.

From the interviews, farmers cultivate rice twice a year. They rent both labourers and machines for cultivating and again for harvesting. Herbicides or Pesticides are used only if really needed. Rice straw is partly collected for feeding cattle while tethered at home, especially during the dry season. The remaining is left on the soil together with rice stubble followed by tillage to prepare the soil for the next cultivation. Only few farmers are willing to confirm that they burn straw to remove this waste. Farmers also sell straw for baling if a professional baler comes on-site. Farmers do tillage the remaining straw and stubble that are left over on the field and use e.g. Urea (46-0-0) and Ammophos (16-20-0) as chemical fertilizers alongside manure as organic fertilizer. Most of small farms buy cattle to be raised for meat production from 4 months to 1 year, then resell it as live-cow to dealers who come to buy on-site. Small farm holders traditionally managed livestock production by tethering the cattle in small plots nearby their house or paddy field. Other animals raised in their farms are buffaloes, pigs, chicken, ducks, fish depending on the household. Some farmers also cultivate other crops for either HH consumption or for trading. The water resource on the farm come from rain and irrigation, as well as wells next to their house. Most of them have a pond fed by canal water . Water from the pond is a back up for farm and household consumption . Sometimes, farmers catch wild fish for their own consumption.

They earn income from selling paddy grain, cattle and other animals they raise. Some household also get income from selling products they picked in the forest.

Referring to the statistic data of the Office of Agriculture Economics (OAE) Thailand for 2011, the average size of small farms was 4.0 ha. 52% of these farms were cultivating rice on 75% of the farm area (3.0 ha). The net annual income of farmers in 2011 from agriculture was 1900 USD/HH, i.e. 37% of their total income (5200 USD/HH).

3200 kg paddy grain/y.ha harvested area were produced. 73% of their ruminant livestock was cattle for meat production. The average number of Cattle was 1.0/HH. Market price of a live-cow Fresh Weight (FW) was 1900 USD/tons. The market prices of urea and Ammophos fertilizer were 0.50 USD/kg and 0.52 USD/kg.

Meanwhile, the data from the Department of Pollution Control (PCD) Thailand in 2009 showed that water consumption for rice cultivation was 13000 m<sup>2</sup>/y.ha. The farms' wash out contaminated with herbicides and pesticides was on average 0.000046 kg/y.ha, which DPC counted as 0 kg/ha.

The general concept of an exemplary small farm system, concluded from statistic data and interviewing, is shown in Fig. 3.1. The process straw production and management in the red box consists of straw production and management (RSM) by feeding cattle and collecting its manure, trading straw, eliminating it by burning on-site, including leaving the remaining straw on the field. This system is the present situation of RSM focused on in this study.

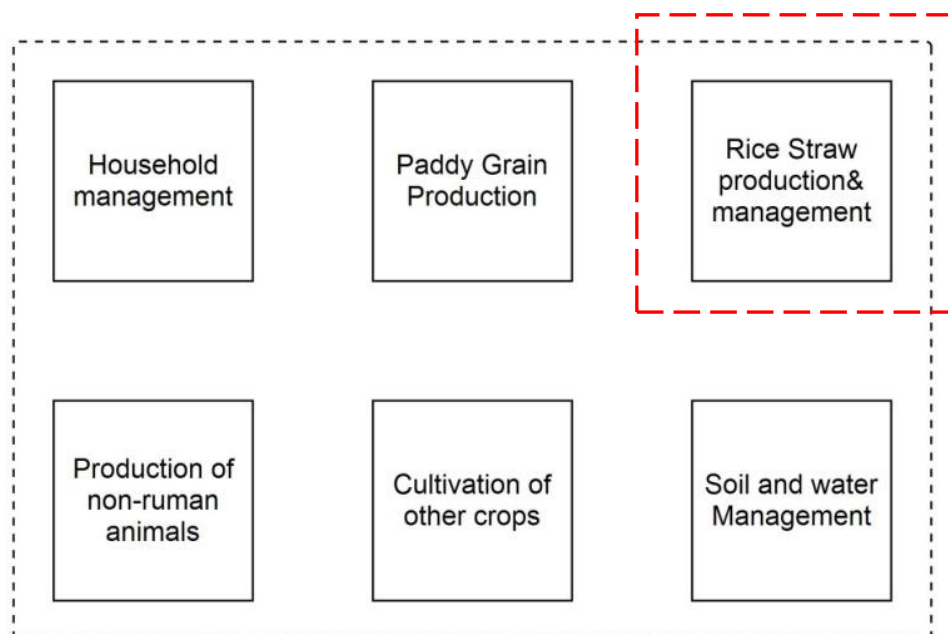

Fig. 3.1. General description of an exemplary small Thai farm for rice cultivation in 2011



## **3.2. Developing a Rice Straw Management (RSM) model**

### **3.2.1. Concept for studying a RSM model**

In this study, RSM is modeled by using STAN software. The RSM model should be consistent with RSM regular practice in order to reduce data differences thereby allowing comparisons with other years.

The concept for studying a RSM model is to simulate the behavior of a RSM unit on an exemplary farm, in order to observe how much resources are needed to produce and manage rice straw as well as how much waste and pollution is emitted by this management. From this study, the change of substrates, products, pollutants, substances (C, N, P) and profits by RSM should be better understood. The results from the model can show weaknesses and strengths of the RSM system in terms of environment, resource efficiency, and economic profits.

The meaning of straw in this study are the dry stalks from rice cultivation, cut over the ground and partly taken away from the field after harvesting.

Stoichiometries and mass ratios are used for defining mass balance equations in the RSM model. The main emphasis is only on the straw flow and its dynamics in order to reduce the complexity of the model by eliminating unnecessary flows.

Based on stoichiometry and mass ratios under status Quo as well as under each scenario, complete balance equations are developed at every level: goods (Dry Weight, DW), substances, and economics. An example of a process equation is described as follows:



or 
$$A + B = cC + dD + \Delta A + \Delta B$$

where A, B = substrate A and B input for the reaction

C, D = product C and D output from the reaction

$\Delta A, \Delta B$  = stock of A and B remaining from the reaction

Unknown values are calculated via the defined mass ratios and mass fraction. In this study, the mass ratio of any output flow/total input flow is called "Transfer coefficient" ( $T_{x/a}$ ). It shows the mass proportion of the mass from the input flow A distributed to the output flow D.

$$D_o = T_{D/A} \cdot A_i$$

Another mass ratio defined in this study is called "Conversion coefficient" ( $M$ ). It is defined as a mass ratio of any 2 focal flows e.g. mass ratio of 2 input flows (A/B), mass ratio of 2 output flows (C/D), or mass ratio of an input flow

and an output flow (A/D). This coefficient is defined together with the additional relation when the relation is needed for STAN to calculate an unknown variable.

For example,  $M$  helps software STAN to calculate the unknown flows when the transfer coefficient of some unknown substances e.g. O, H, etc., which are not the focal substance and their mass fraction cannot be defined by any substance layer. In this case, STAN needs additional relations, sufficient for calculating unknown values.

This coefficient is also used for calculating processes with a stock for which a transfer coefficient cannot be defined in STAN as it also needs the additional relations for this mass ratio to be defined. Furthermore, this mass ratio also simplifies STAN's work by using this mass ratio from the balance equations to calculate directly instead of by defining elemental distribution in the subsystem.

Some equations with concepts of  $M$  are demonstrated as follows:

$$A_i = M_{A/C} \cdot C_o$$

$$A_i = M_{A/B} \cdot B_i$$

"Mass Fraction ( $F_x$ )" is defined as a ratio of material content ( $x$ ) in compound (A), as shown in the equation below:

$$x = F_x \cdot A$$

Price ( $PA$ ) and cost ( $C_A$ ) factors, defined as price or cost of A per mass unit. Price of A is calculated from weight of A ( $M_A$ ) as shown below:

$$P_A = P_A \cdot M_A$$

### 3.2.2. Tool to study RSM

Material Flow Analysis (MFA) is a tool to analyze straw dynamics while Substance Flow Analysis (SFA) is another tool to analyze substance dynamics in the RSM. In addition, economic Analysis (EA) is a tool to analyze economic profits of the system. All flow analysis are used for evaluating and comparing material, elemental, and economic differences of RSM in the improved Scenarios with "Status Quo" .

System boundaries are defined in terms of spatial and temporal boundaries. Spatial boundary is 1 ha of farm space over the ground for RSM. The temporal boundary of the system is 1 year of regular RSM practice. The input flows are substrates for producing and utilizing straw as well as RSM residues. The output flows are traded products and wastes from farm emitted to the environment.

In MFA , SFA and EA, the Data input into the system is straw in order to calculate the remaining data in the systems from straw production until utilization. Other inputs are only used for completing straw production and conversion regarding its chemical and biochemical reactions The Data Outputs are the changes of products from RSM e.g. Weight gain of Protein in Livestock, waste converted from straw burning and from straw utilization, as well as economic profits as money. In EA, data input of the system is any operational cost and data output is the economic profit in terms of money.

To simplify the model which is focusing only on straw dynamics, any process required for RSM is located within the system boundary and named "System Process". The complex processes for collecting the export flows from the systems are outside of the system boundary, named "Environmental Subsystems". These subsystems, i.a. "Pedosphere and Hydrosphere" as well as "Atmosphere" are the natural sinks of straw and its related substances emitted to the environment. Including all of them in the boundary would make the system too complex.

### 3.3. Data selection and uncertainty

The main data used in this study are secondary data. Secondary data reported by reliable organizations such as IPCC, FAO, OAE, DPC, Department of Livestock Development (Thailand), and scientific literature cited are used for establishing a data base for modeling small farms in Thailand including data calculations. Data used for calculation is country or locally specific data in order to avoid any uncertainty concerning i.a. environment, climate, geography, methods, etc, unless it either does not exist or it is too varied. In that case, default or universal data from international organizations is chosen. Primary data from laboratory analysis is also used where no secondary data exists.

Statistic data sets on rice cultivation in Thailand in 2011 are chosen as they are the most complete to calculate rice straw and general characteristics of small farms. Therefore, other data e.g. pollutant emissions, monetary costs

and value, etc., are also chosen from the same year. If they do not exist, those from a similar year are chosen. The lists of data chosen in this study are collected in Annex.

The uncertainty from primary data is defined at 10%. Due to the unavailability of uncertainty data of secondary data, the uncertainty of input data referring to similar conditions in this study e.g. similar type of plants, animal, methods, climate, etc is set at 20%, based on the guidelines of IPCC (2006) for national data, population data, and estimated data on digestibility. The uncertainty from universal or default data is assumed to be 30%. The uncertainty of N<sub>2</sub>O and PM emissions in this study are assumed to be 100%, based on their large uncertainty, according to IPCC (2006).

### **3.4. Analysing and Evaluating of the model**

The software STAN is chosen for drafting the model for calculating the material flows and stocks in MFA, substance flows and stocks in Substance Flow Analysis (SFA), and economic profits in Economic Analysis (EA). Selected data and uncertainty are added into the drafted model in STAN to allow the software to calculate the results. Values are reported in 2 significant decimals. In addition to STAN, Excel has been used for additional calculations as well as for drawing graphs of results.

The quantitative results from Status Quo and the scenarios are taken to evaluate the impacts on the environment, resource efficiency, and economic profits by the indicators mentioned in Table 3.1 below in order to assess effectiveness of the measures taken.

Table 3.1. Indicators to assess the effectiveness of Scenarios compared with Status Quo

Evaluation of the impacts on	Indicators	Units
Environment	The emissions of CO <sub>2</sub> e, CO, Particulate Matter (PM)	kg/y.ha
Resource management	The distribution of substances from total substances input for straw production and utilization in the RSM products	% distribution of substances to RSM products from total input
Economic Profit	The farm's income from straw utilization	USD/y.ha

### **3.5. Quantification of Status Quo**

#### **3.5.1. Concept for developing the model "Status Quo"**

The concept for developing the model "Status Quo" is to simulate the present system of RSM on small Thai farms in order to quantify its impacts and effectiveness by MFA. The equations in each process of "Status Quo" represent the traditional management of straw *i.a.* straw production and distribution, burning (RSOB), livestock production, manure collecting, including chemical distribution for straw production. Cattle is the tool in the process "livestock Digestion" for converting straw to end products.

The input flows in Status Quo are the substrates for straw production including utilization of straw and RSM of residues e.g. CO<sub>2</sub>, chemical fertilizers, substances from soil, etc. Nitrogen added for livestock production is contained in naturally growing thus free plants. The chemical fertilizers Urea (46-0-0) and Ammophos (16-20-0) are also added in this system in order to complete the ratio of N and P that plants should absorb for straw production.

The output flows in this model are RSM products, residues, and waste from the RSM system. Its products are livestock weight gain and traded straw. Its residues and waste are *i.a.* left-over straw, manure, fertilizer residue released to farm soil, and air pollutants. As all substrates and products are either consumed or traded, they do not remain in the system, their stock in the system is therefore defined as 0. Stocks from the environment, *i.a.* farm soil, atmosphere, as well as undefined hydrosphere and pedosphere exist to observe pollutants and substance accumulation.

All gases taken from/released to the environment have no micro-economic costs. The secondary costs of rice production *i.e.* labour, plant hormones, pesticides etc., are not included in the analysis because this study focuses only on the RSM unit on farms. The other units in the same farm, especially paddy grain production, will remain unchanged between Status Quo and the improved scenarios. Therefore, secondary costs of both statuses are equal and therefore irrelevant. In order to categorize the different flows in the system, the colours of flows in MFA are defined for different meanings. "Orange flows" mean flows of straw. "Grey flows" mean any flow of material or substance to complete the system calculation. "Red flows" mean the flow of pollutants. "Blue flows" mean the flow of products for trading. "Green flows" are pure money flows for profits. "Pink flows" are money flows for costs. The blue-box Processes are defined as subsystems with the internal processes in order to calculate a series of equations.

In order to calculate EA of RSM in STAN, the concept of material balance for stock equation used in STAN has to be applied as an example:

$$\Delta\text{stock} = \text{import flow} - \text{export flow}$$

To implement STAN for calculating money profits gained, import flows (material costs) and export flows that pass the system boundary have to be technically defined as minus. Cost and value of waste and residues are defined as 0.

Following the stock equation, the profit equation is as follows:

$$\Delta\text{Profit} = (-\text{cost of import materials}) - (-\text{market price of exported traded-products})$$

The profit's equation above can be rearranged to:

$$\Delta\text{Profit} = \text{Price value of export product} - \text{cost of import materials}$$

Constant values, coefficients, and mass fraction for calculating processes in Status Quo and in all scenarios are either calculated in this study or selected from data, are listed in the annex. The concept of Status Quo is concluded in Fig. 3.2.

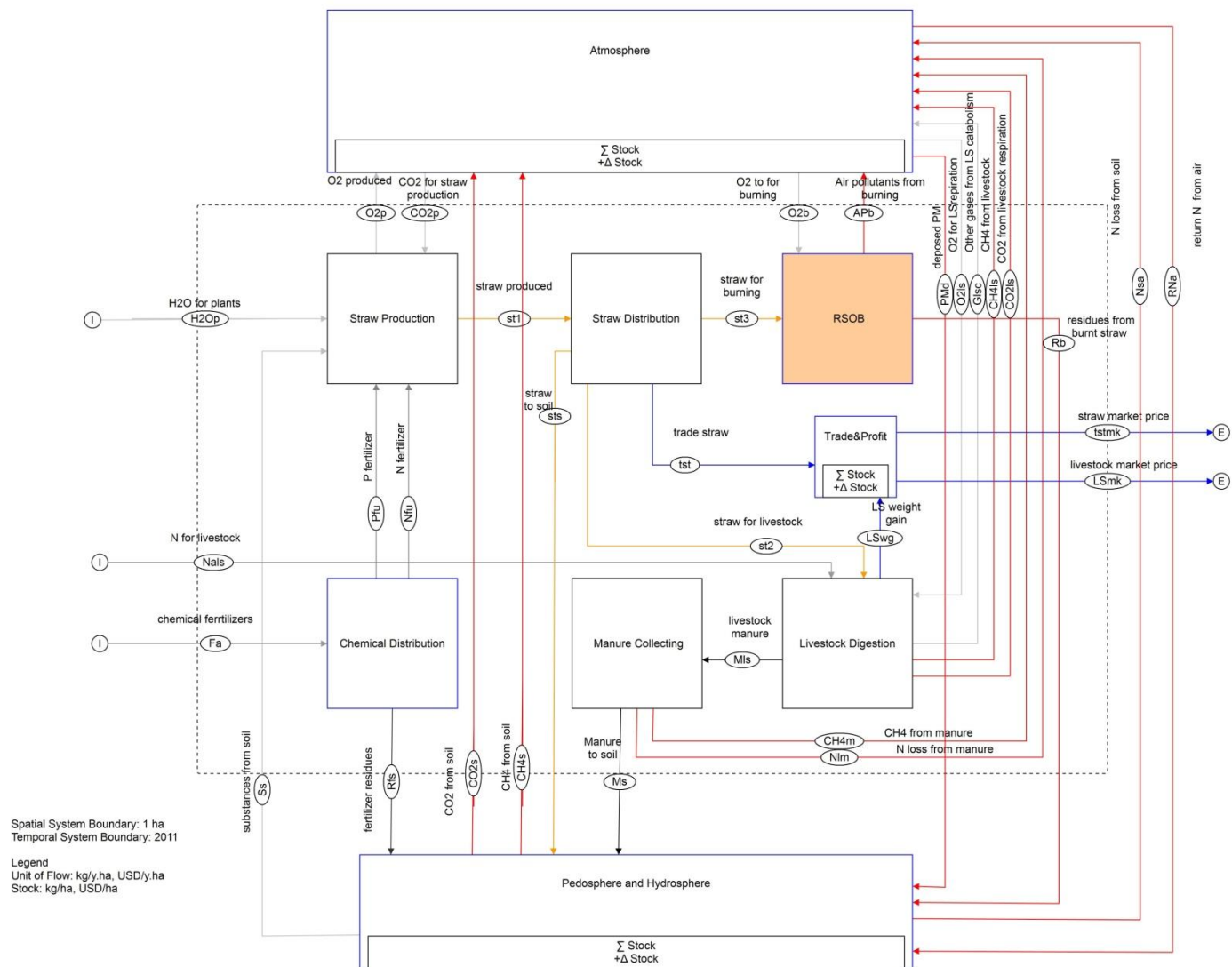

Fig.3.2. MFA per ha in "Status Quo" on an exemplary farm in 2011 (no values shown)

### 3.5.2. System development for "Status Quo"

#### 3.5.2.1. System Process "Straw Production"

A certain amount of straw is converted from a certain amount of paddy grain produced in 2011 according to the ratio of straw/grain (B) of Devandra (1985). A complete set of data by Jenkins (2003) is selected. 91% of substances in straw are converted to the elemental formula  $CH_{1.2}O_{0.80}N_{0.015}P_{0.0016}$ . The remaining contains other trace elements e.g. K, Na, Mg, Ca, S, etc. 17% of substances in straw are mixed together in a complex way, e.g. straw ash.

The combination of photosynthetic equations and material balances in stoichiometry is the key for calculating the material's proportions for straw produced (st1, as follows:

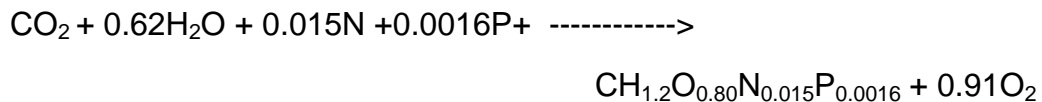

where N, P= the additional nutrients absorbed by rice plants to produce straw

Other substances ( $M_{Ss}$ ) in straw are calculated by subtraction of mass balance equation in order to complete straw's molecular weight.

define  $M_x$  =Mass of substance X

$$M_C + M_O + M_H + M_N + M_P + M_{Ss} = M_{st1}$$

As the contents of available N and P existing in soil ( $N_{Ss}$ ,  $P_{Ss}$ ) are not sufficient enough, N and P from fertilizers ( $N_{fu}$ ,  $P_{fu}$ ) are added in order to complete the nutrient requirements at the level of N and P composition in straw. An example equation of N and P calculation is shown in the following equation:

$$N_{st1} = N_{Ss} + N_{fu}$$

#### 3.5.2.2. System Process "Straw Distribution"

In this process, straw (st1) is used by traditional RSM as animal feed (st2), as the residue for burning on-site (st3), as goods to be traded (tst) and as the left-over straw on the paddy field (st<sub>s</sub>). The transfer coefficient for distributing straw utilization ( $T_{stx/st1}$ ) in Thailand is concluded from the data done by Questionnaire data of DEDE (2003) and from data from Satellite Imageries of Choenchoklin *et al* (2010), compared with the data from interviewing. The process equation is as follows:

$$st_1 = st_2 + st_3 + tst + st_s$$



### 3.5.2.3. System Process "RSOB" and its subsystem

Straw ( $st_3$ ) contains the combustible part ( $st_{cb}$ ) and non-combustible part or residue from burning ( $R_b$ ).

$$st_3 = st_{cb} + R_b$$

By burning, various air pollutants ( $AP_b$ ) e.g.  $CO_2$ ,  $CO$ ,  $CH_4$ ,  $N_2O$ ,  $NO_2$ , and  $PM$ , are generated from the chemical reaction of the combustible part and oxygen. Oxygen in this process oxidizes the combustible part ( $O_{2b}$ ). The residue from burning remains and accumulates in soil. This process is concluded in Fig. 3.3. The process equation is as follows.

$$st_3 + O_{2b} = AP_b + R_b$$

where

$$AP_b = CO_{2b} + CO_b + CH_{4b} + NO_{2b} + N_2O_b + PM + \text{others}$$

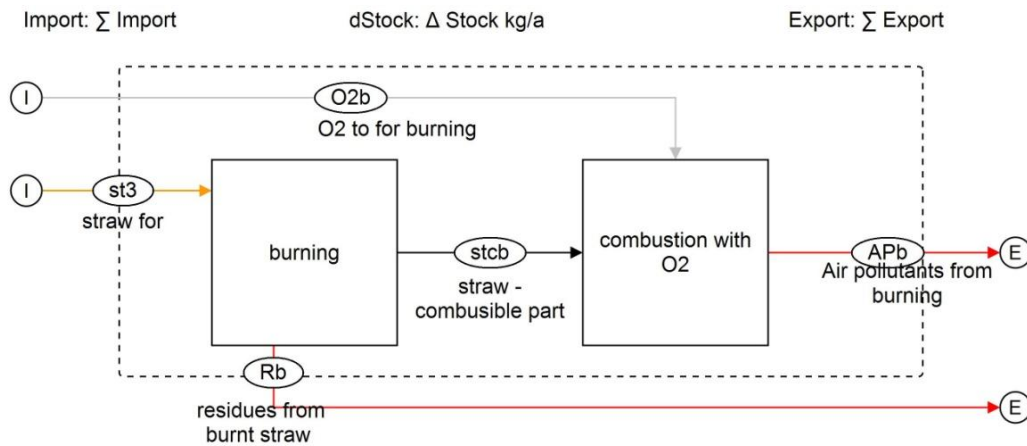
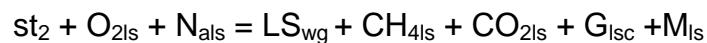

Fig. 3.3. Subsystem in process "RSOB"

Emission of major pollutants i.a.  $CO_2$ ,  $CO$ ,  $CH_4$ ,  $N_2O$ ,  $NO_2$ , and  $PM$  are calculated, as well as the amounts of Oxygen needed for combustion. Combustible factor ( $CF_x$ ) and emission factor ( $EF_x$ ) are selected from experimental data of the same region from literature e.g. Kanokkanjana and Gariviat (2013), Singh *et al* (2008), Oanh *et al* (2011), Christian *et al* (2003), underpinned by default data from international organizations i.a. IPCC (2006). For STAN calculation, the combustible factor is defined as a transfer coefficient ( $T_{stcb/st3}$ ) in STAN in order to calculate the amounts of the combustible part of straw and its substances ( $st_{cb}$ ). The emission factor of each air pollutant ( $Y_b$ ) is defined as a conversion factor calculated from straw's combustible part ( $M_{Y_b/stcb}$ ) or from straw ( $M_{Y_b/st3}$ ) by general mass ratio equations mentioned in paragraph 3.2.

### 3.5.2.4. System Process "Livestock Digestion"

Livestock in this process is defined as a cattle ( $\text{CH}_{0.40}\text{O}_{0.30}\text{N}_{0.25}\text{P}_{0.0010}$ ) owned by farmer. Its molecular formula is defined from data by IPCC (2000) and by Stewart (2013). In this process, cattle converts straw into different products. As straw has not enough N for cattle, supplement N from free wild plants is added into the process in order to fulfill the N requirements of the cattle. In Cattle's digestive system, fed straw ( $st_2$ ) is digested, catabolized aerobically by cattle's respiration as well as through anaerobic fermentation by the rumen bacteria. From these processes, chemical energy of straw, substances from straw as well as  $\text{O}_2$  ( $\text{O}_{2ls}$ ) and the free N-source ( $\text{N}_{als}$ ) are distributed into different products. Substances and energy together forms new products i.a. Cattle tissue ( $\text{LS}_{wg}$ ), methane ( $\text{CH}_{4ls}$ ), Carbondioxide ( $\text{CO}_{2ls}$ ) and other gases from catabolism ( $\text{G}_{isc}$ ), e.g.  $\text{H}_2\text{O}$ . The remaining is secreted out as waste, called manure. In this study, manure ( $\text{M}_{ls}$ ) is the combination of cow's faeces and urine. The livestock in this process is raised by the farmer for only 4 months to 1 year, then sold to traders. Therefore, weight gain of the stock ( $\Delta\text{LS}_{wg}$ ) is defined as 0. To simplify the model and delete unnecessary flows, livestock weight gain is only a focal point to identify how much straw can be converted while livestock's input has the same composition and cost of its live weight. Therefore, livestock's input is not calculated. The process equation is as follows:



The energy distribution from feed consumption by cow from birth to maturity concluded by Weiss (2007) is an estimation to find the proportion of straw dynamics in the digestion process in order to calculate the changes in this complex biochemical process. Straw for livestock ( $st_2$ ) is defined as the only focal substrate for energy disbution. In this process, the chemical energy is divided in several parts, i.a. as tissue energy in livestock's tissue ( $\text{LS}_{wg}$ ), as gas energy in  $\text{CH}_4$  ( $\text{CH}_{4ls}$ ) converted by methanogenic bacteria in the cattle's rumen, as heat energy generated together with  $\text{CO}_2$  ( $\text{CO}_{2ls}$ ) from cattle's respiration and catabolism to produce its energy for daily activities, and as manure energy in manure ( $\text{M}_{ls}$ ). The distribution of chemical energy in straw is concluded in the following equation.

energy in straw fed = tissue energy + gas energy + heat + manure energy

The equation above is equivalent to the same proportion of Carbon distribution from straw by digestion as C is the only substance distributed from straw to every product mentioned in the energy distribution. With C balance, the mass of remaining materials and substances for this process can be calculated from the process equation. Mass balance of C is as follows:



Not only energy ratios are used as a conversion factor for calculating C dynamics in the process, but also the conversion factor  $O_2$  is calculated from the mass stoichiometry of cattle's respiration. This stoichiometry is based on catabolism of straw into  $CO_2$ ,  $H_2O$ ,  $NH_4^+$ , and P in various forms, as follows:

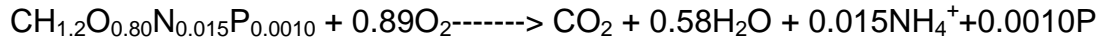

### 3.5.2.5. System Process "Manure Storage"

In traditional RSM, farmers collect livestock's manure ( $M_{Is}$ ), leaving it outside until it dries. Afterwards, the dry manure is piled or filled into a big bag and kept for using as a whole as fertilizer ( $M_s$ ) for the upcoming cultivating season, i.e. for 4-6 months. Therefore, the manure stock ( $\Delta M_s$ ) is defined as 0. In the drying process, total N loss from manure ( $N_{Im}$ ) is mainly  $NH_3$ -N to atmosphere by ammonia evaporation including  $N_2O$  which is only 1% of this total N loss.  $CH_4$  ( $CH_{4Im}$ ) is also emitted from kept manure via microbial fermentation. The process equation is concluded as follows:

$$M_{Is} = N_{Im} + CH_{4Im} + M_s$$

The N loss varies because of different methods of collecting and storing. The amounts of N loss ( $N_{Im}$ ) relate to the remaining N in manure after the evaporation (nitrogen effectiveness,  $E_{N/Ms}$ ), base on a report data by FAO (2001). Its transfer coefficient ( $T_{N/Ms}$ ) is calculated as follows:

$$T_{N/Ms} = 1 - E_{N/Ms}$$

Transfer coefficient of Methane ( $T_{CH_{4Im}}$ ) is calculated from the equation and constant value of  $CH_4$  emissions according to IPCC (2000) in order to change the measuring unit of methane from "total volume" to "mass ratio", as follows:

$$T_{CH_{4Im}} = D_{CH_4} \cdot (B_{oa} \cdot C_{VSm} \cdot MCF \cdot MS)$$

Where  $D_{CH_4}$  = density of methane ( $kg/m^3$ )

$C_{VSm}$  = mass fraction total volatile solid in dry manure ( $kgVS/kgM_{Is}$ )

$B_{oa}$  = Biodegradability of manure in Asia ( $m^3CH_4/kg VS$ )

MCF = methane conversion factor in warm climate and dry lot

MS = manure usage's ratio

The value of the specific parameters in the equation above is selected under the condition of low cost management in a warm climate. MS in this process is defined as 1 because the farmer uses 100% of the manure in this practice.

### 3.5.2.6. System process "Chemical Distribution" and its subsystem

In addition of available phosphorus and nitrogen in the soil ( $N_{SS}$ ,  $P_{SS}$ ) for plants to produce straw during rice cultivation, the farmers have to add chemical fertilizers ( $F_a$ ) in order to supply all nutrients that plants need. Fertilizer absorption by plants is not 100% due to physical phenomena in nature. Therefore, only certain amounts of N and P ( $N_{fu}$  and  $P_{fu}$ ) can be used by plants. The residue fertilizers (RFs) accumulate in the environment e.g. soil, water. The process equation is concluded as follows:

$$F_a = N_{fu} + P_{fu} + RF_s$$

As Urea ( $F_{ur}$ ) and Ammophos ( $F_{am}$ ) are the most common fertilizers the farmers use for rice cultivation, Ammophos is the inorganic N and inorganic P source in this study, while Urea is the main inorganic N source farmers use for providing N for plants. N that plants use can be concluded as follows:

$$N_{fu} = N_{am} + N_u$$

N and P from soil are defined as the first source of plant nutrients in this study. The values phosphorus and Nitrogen from chemical fertilizers added are base on data of Rehm *et al* (2002) and Ongprasert (2004). These values are used as conversion factors ( $M_{P_{fu}/P_{Fam}}$  and  $M_{N_u/N_{Fur}}$ ) for calculating the amounts of N and P added from each fertilizers ( $N_{Fur}$  and  $P_{am}$ ).

$$N_{Fur} = M_{N_u/N_{Fur}} \cdot N_u$$

$$P_{am} = M_{P_{fu}/P_{Fam}} \cdot P_{fu}$$

Subsystem of this process is shown in Fig. 3.4.

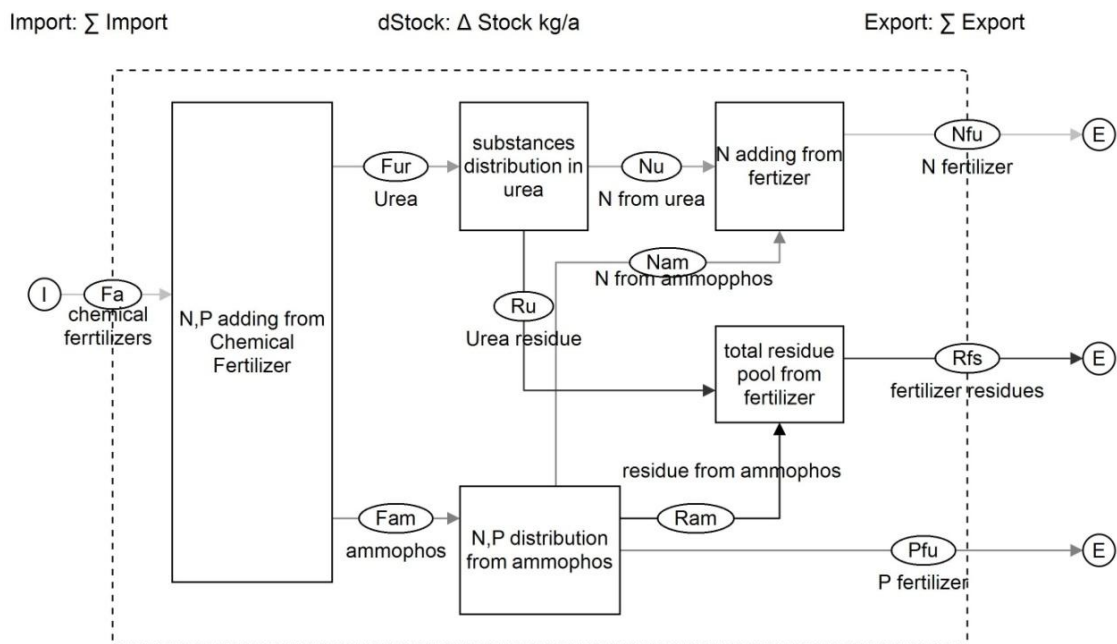

Fig. 3.4. Subsystem in process "Chemical Distribution"

### 3.5.2.7. System process "Trade&Profit" and its subsystem

This subsystem is a system process within the system boundary containing internal processes: Trading processes, and Money Profits. (Fig. 3.5). As all purchases and profits by farmers are done at the farm, this subsystem remains in the system boundary. The goods from the RSM: trade straw (tst) and livestock weight gain (LS<sub>wg</sub>) are traded at the market price of goods. Traded straw is sold to traders who purchase unbale straw at the farm and bale it on-site with their own machinery. Livestock traders also come to purchase the cattle from the farmers on-site. Both goods i.a. trade straw market price (tst<sub>mk</sub>) and livestock market price (LS<sub>mk</sub>) are exported to traders while the pure money flows (P<sub>st</sub>, P<sub>LS</sub>) from both trading processes are calculated for the total profit.

As all goods produced from the system are calculated as goods dry weight, all market prices are converted from Live weight Price (P<sub>LW</sub>), as follows:

$$P_{DWx} = \frac{P_{Wx} \cdot 100}{\%DWx}$$

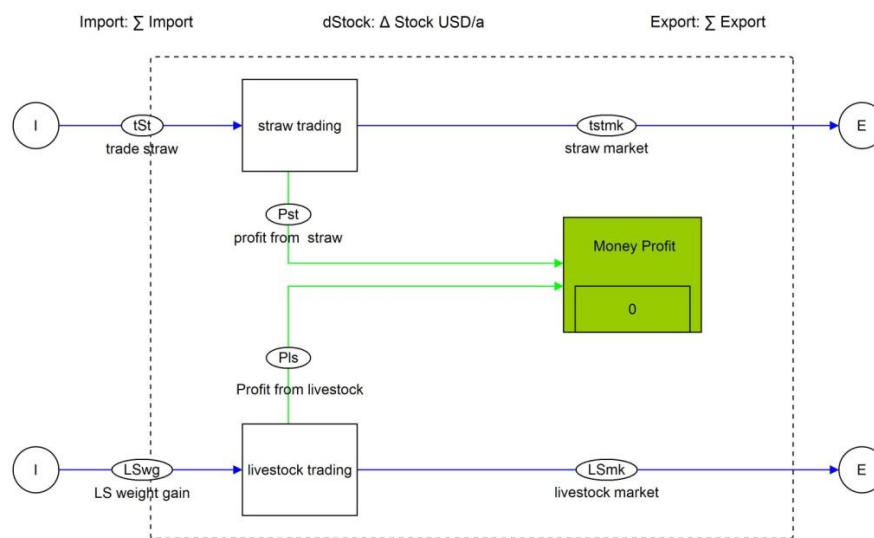

Fig. 3.5. Subsystem in process "Trade&Profit"

### 3.5.2.8. Environmental Subsystem "Pedosphere and Hydrosphere"

This process is defined as 3 natural sinks i.e. farm soil, undefined location of hydrosphere, as well as undefined location of pedosphere, for the exported materials from RSM. The process boundary of this subsystem extends from the soil surface of farm soil to the underground water, including the water body of hydrosphere receiving water flowing through the RSM system and undefined pedosphere and hydrosphere containing the substances deposited from the atmosphere.

The focal output data are the quantitative changes of substances in the soil and hydrosphere sinks in order to observe the substance's dynamics. Unfortunately, the existing and updated data of C, N, and P in soil from paddy fields and water in Thailand are not complete. These data are therefore not chosen for STAN calculation. Thus, the values of substance stocks in this subsystem are defined as 0 in order to reduce error warning from STAN. In any event, Material dynamics from every year are assumed to be the same.

In this subsystem (Fig. 3.6), all substances flowing into the soil are from left-over straw ( $st_s$ ) as well as the residues from burning ( $R_b$ ), unavailable parts of chemical fertilizers ( $Rf_s$ ), the manure as organic fertilizer ( $M_s$ ), PM deposited from atmosphere ( $PM_d$ ), including N deposited from atmosphere by rain ( $RN_a$ ). The output flows are mixed substances for plants absorbed during straw production ( $S_s$ ), N loss to atmosphere ( $N_{sa}$ ), and  $CO_2$  and  $CH_4$  from organic decomposition ( $CO_{2s}$  and  $CH_{4s}$ ). In this study, all substances deposited from the atmosphere are defined to be only accumulated in undefined pedosphere and hydrosphere but not counted for rice straw production due to their unpredictable locations.

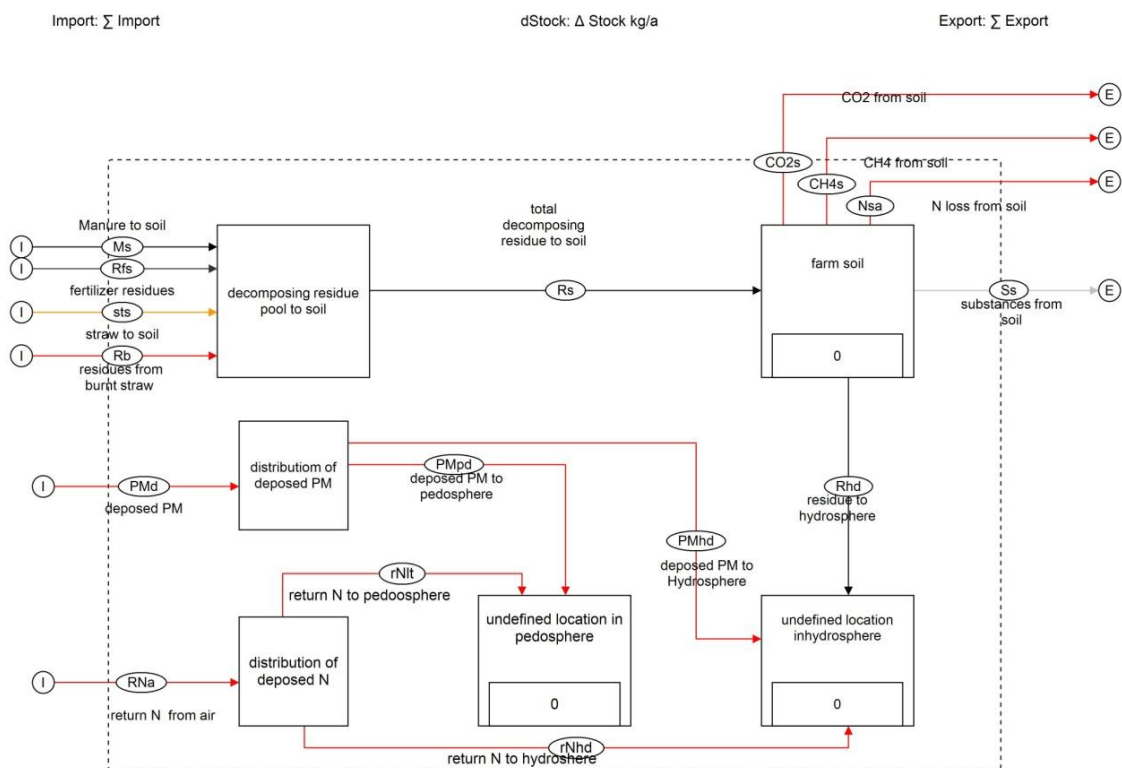

Fig. 3.6. Environmental subsystem "Pedosphere and Hydrosphere"

During the cultivating stage, farmers flood the paddy field in order to cultivate the rice which induces an anaerobic condition in soil. The fermentation by soil microorganisms decompose organic matter. Organic C is converted into CO<sub>2</sub> and CH<sub>4</sub> (CH<sub>4s</sub>). Farmers drain the water at the end of cultivation and harvest the paddy grain. The soil is left dry until the next round of cultivation. At this stage, the aerobic respiration in soil produces CO<sub>2</sub>. CO<sub>2</sub> from soil (CO<sub>2s</sub>) comes not only from organic decomposition, but also from demineralization of urea fertilizer (C<sub>RFS</sub>). The remaining C mainly accumulates in farm soil (ΔC<sub>SO</sub>) and is partly leached to end up at undefined location in the hydrosphere (ΔC<sub>HD</sub>). The balance of C in soil is as follows:

$$C_{sts} + C_{Rb} + C_{MIs} + C_{Rfs} + C_{PMd} = C_{CO2s} + C_{CH4s} + \Delta C_{SO} + \Delta C_{HD}$$

Parts of N emitted into farm soil are decomposed or mineralized in soil then converted to ON. Afterwards, it is slowly released and adsorbed by plants (N<sub>Ss</sub>). Some of N is volatized into the atmosphere via denitrification in soil (N<sub>sa</sub>). N is also partly leached by water and accumulated in undefined locations in the hydrosphere (ΔN<sub>HD</sub>) while the deposited N and PM also accumulates in undefined locations of the hydrophere and pedosphere (ΔN<sub>PD</sub>). The remaining N is accumulated in soil sink (ΔN<sub>SO</sub>). N balance in soil is as follows:

$$N_{sts} + N_{Rb} + N_{MIs} + N_{Rfs} + N_{PMd} + N_{RNa} = N_{Ss} + N_{sa} + \Delta N_S + \Delta N_{HD} + \Delta N_{PD}$$

Part of P emitted into farm soil are mineralized in soil then partly converted to OP which is then slowly released and adsorbed by plants (P<sub>Ss</sub>). Some of it binds with soil ion. P is also partly removed by water and accumulated in undefined location in hydrosphere (ΔP<sub>HD</sub>) while the deposited P from PM also accumulated in undefined hydrophere and pedosphere (ΔP<sub>PD</sub>). The remaining P is accumulated in soil sink (ΔP<sub>SO</sub>). N balance in soil is as follows:

$$P_{sts} + P_{Rb} + P_{MIs} + P_{Rfs} + P_{PMd} = P_{Ss} + \Delta P_{SO} + \Delta P_{HD} + \Delta P_{PD}$$

The conversion factors for this process are developed from the references in annex e.g. the experimental data in Thailand from Thammasom *et al* (2013), Phaoseeha and Pengdhammakitti (2011), DPC Thailand (2011), as well as literature data from Lory *et al* (2007), Rehm *et al* (2002), and IPCC (2006).

### 3.5.2.9. Environment Subsystem "Atmosphere"

This subsystem is defined as a sink of the air pollutants emitted from RSOB ( $A_b$ ), from other processes in the system, e.g. Livestock digestion ( $I_s$ ), from manure collecting ( $M_{I_s}$ ), as well as from soil ( $S$ ). It also provides  $CO_2$  for straw production as well as  $O_2$  for RSOB and for livestock digestion in the RSM system. The total emissions of the main pollutants into the atmosphere sink are evaluated. The transfer coefficients and conversion factors in this subsystem are from IPCC (2006).

total GHG are quantified total emissions of each GHG from the system i.e.  $CO_2$  ( $CO_{2ta}$ ),  $CH_4$  ( $CH_{4ta}$ ) and  $N_2O$  ( $N_{2Ota}$ ), multiplied by its default conversion factors, as follows:

$$GHG = CO_{2ta} + 21CH_{4ta} + 310N_{2Ota}$$

where

$$CO_{2ta} = CO_{2Ab} + CO_{2Is} + CO_{2s}$$

$$CH_{4ta} = CH_{4Ab} + CH_{4LS} + CH_S$$

$N_2O$  in Status Quo is released mainly from RSOB ( $N_{Ab}$ ). Few amounts of this gas are also emitted from total volatile N ( $N_s$ ) from manure ( $N_{Im}$ ) and from soil ( $N_{sa}$ ). The equation is concluded as follows:

$$N_{2Ota} = N_{Ab} + N_{2Os}$$

where

$$N_{N_2Os} = 0.01 (N_{sa} + N_{Im})$$

In this study, PM is defined as  $PM_{2.5}$  to  $PM_{10}$ . PM and CO are only emitted via RSOB, therefore,

$$CO_{ta} = CO_{Ab} \quad \text{and} \quad PM_{ta} = PM_{Ab}$$

$CH_4$ , CO, and  $N_2O$  are accumulated in the atmosphere, while  $CO_2$  is assimilated back by photosynthesis. All of N from  $NO_2$  of RSOB ( $N_{NO2b}$ ), and remaining volatile N (RNs) are deposited back to undefined locations of the pedosphere and hydrosphere ( $R_{Na}$ ). Therefore,

$$PM_{Ab} = PM_d$$

$$R_{Na} = N_{NO2b} + (N_{sa} + N_{Im}) - N_{N_2Os}$$

This subsystem is shown in Fig.3.7.



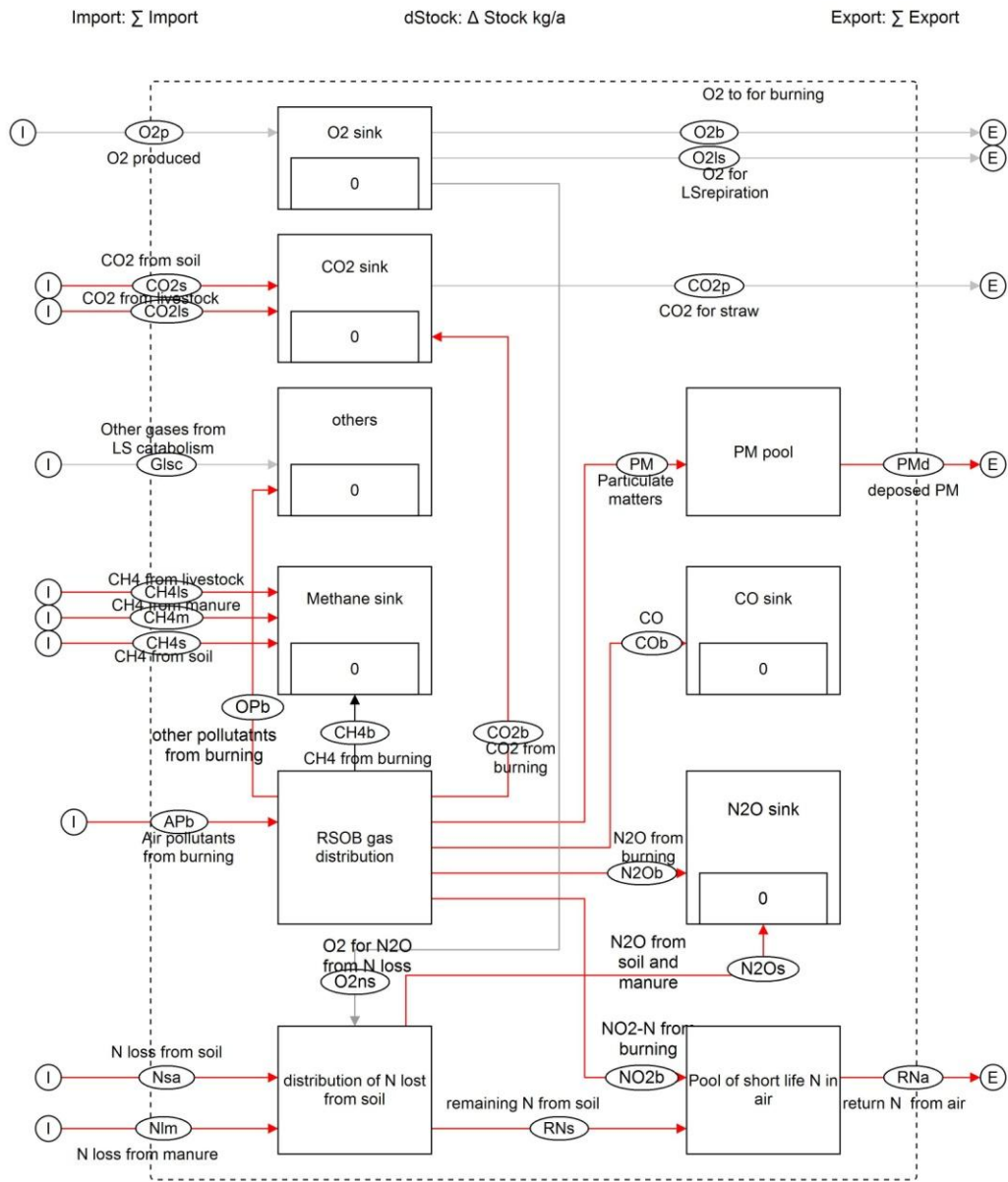

Fig. 3.7. Environmental subsystem "Atmosphere"

### **3.6. Scenario Analysis**

#### **3.6.1. Goal of scenario analysis**

As RSOB process in "Status Quo" emits air pollutants to the atmosphere affecting human health and the environment on top of the problem of losing nutrients from the paddy field, replacing RSOB with other proper technologies should contribute solutions for the above issues.

As mentioned before, income is the main motivating factor for mainly uneducated farmers to utilize straw instead of burning it via RSOB, the alternative methods replacing RSOB should increase the HH's economic benefits from better resource efficiency. Furthermore, it should reduce environmental problem causes by RSOB. At the same time, it should be easily handled and less labour intensive to avoid complications from the lack of knowledge especially of farmers and their families. Therefore The concept of selected technology is "Simplicity - Higher income - Lower emissions"

Each single product from straw i.a. food, feedstock, energy, or construction material are analysed and evaluated in each scenario the approaches implemented according to the concepts above.

The results of each scenario analysis shows the effectiveness in terms of the environment, resource management, including farm economics. The technologies and results from scenario analysis are subsequently combined in a single optimized scenario to propose an optimal solution.

#### **3.6.2. Developing of scenarios**

To analyze the behavior of the system under alternative technologies, several scenario analysis are implemented. RSOB in Status Quo's system is the only process to be replaced with alternative processes created from each single technology to produce its product directly from straw usually burnt by RSOB process ( $s_{tb}$ ). 4 new scenarios are studied, i.e. scenario food producing mushroom, scenario fodder to produce feedstock, scenario energy to produce biogas, as well as scenario construction to produce straw brick, respectively. With scenario analysis, the effectiveness of using new processes in the system is compared.

In every improved scenario, utilized straw *i.a.* for trading, straw for livestock feeding, including straw otherwise burnt is baled by farmers before utilizing in order to be kept properly before utilizing or trading.

Most of the equations in each process of "Status Quo" except RSOB are the same to make the system behavior in the different improved scenarios comparable. The equations for the baling process, mushroom cultivation, straw treatment as feedstock, biogas digester, including straw-brick production therefore take into account the additional treatment as opposed to traditional straw handling. MFA, SFA, and EA are studied. Data input as well as temporal and spatial system boundaries of scenario analysis are still same

as those in Status Quo. For EA, Nitrogen added for livestock and mushroom production is contained in naturally growing thus cost free plants. The economic benefits stemmed both from direct incomes by trading products and from indirect incomes from money savings as farmers would use their own product e.g. biogas instead of buying LPG. Besides, any additional costs for the improved scenarios from traditional management are calculated, e.g. fuel, labour, etc. On an assumption that there should be no heavy machinery costs for the farmers as all heavy machines used in the improved Scenarios should be bought by a village fund supported from the government if available, and then owned by the farmer's community which lends them to the farmers when needed.

The output flows as the indicators for scenario analysis are same as those for Status Quo, as mentioned in paragraph 3.4.

In scenario analysis, the substances analysis of materials and waste from construction and operation e.g. container waste from mushroom, concrete for construction, fuel, etc., are not counted as they are not involved directly in substance dynamics of straw utilization (the focal flows). At the same time, they vary depending on farmers choices and there is no data available either. Their amount of material for construction and operation is used only for calculating the operation cost while fuel amount is used for calculating cost and only CO<sub>2</sub> emission due to the reasons mentioned above.

### 3.6.2.1. Scenario A "Food"

This scenario gives the advantage to the farmers to generate supplementary income from trading mushroom under high demand in the market. Furthermore, it can be the a supplement food source for their family.

#### A) System Process "Baling" and its subsystem

As baling is the first step, diesel oil is used for the baling process. Total cost for baled straw ( $Co_{stba}$ ) in this process is the cost from straw production i.a. fertilizers ( $Co_{st1}$ ) and baling cost ( $Co_{bast}$ ), i.e. 4 labourers for 1 day as well as material costs. The equation of baling costs is concluded as follows.

$$Co_{stba} = Co_{st1} + Co_{bast}$$

$CO_2$  is the main pollutant from its combustion. Its emission is therefore calculated from C oxidized from oil ( $C_{oil}$ ). The equations for  $CO_2$  emission and costs are as follows.

$$C_{CO2} = C_{oil} \cdot T_{Cco2/Coil}$$

All coefficients for mass and costs of straw baling are from an experiment in Thailand of Chinawerooch et al (2014) while the composition of diesel and  $CO_2$  emissions are from US-EPA (2005). PM and other pollutants from diesel combustion are not calculated as they are not from direct straw utilization. At the same time, it depends on the diesel and engine type for which precise data do not exist.

This subsystem is concluded in Fig. 3.8.

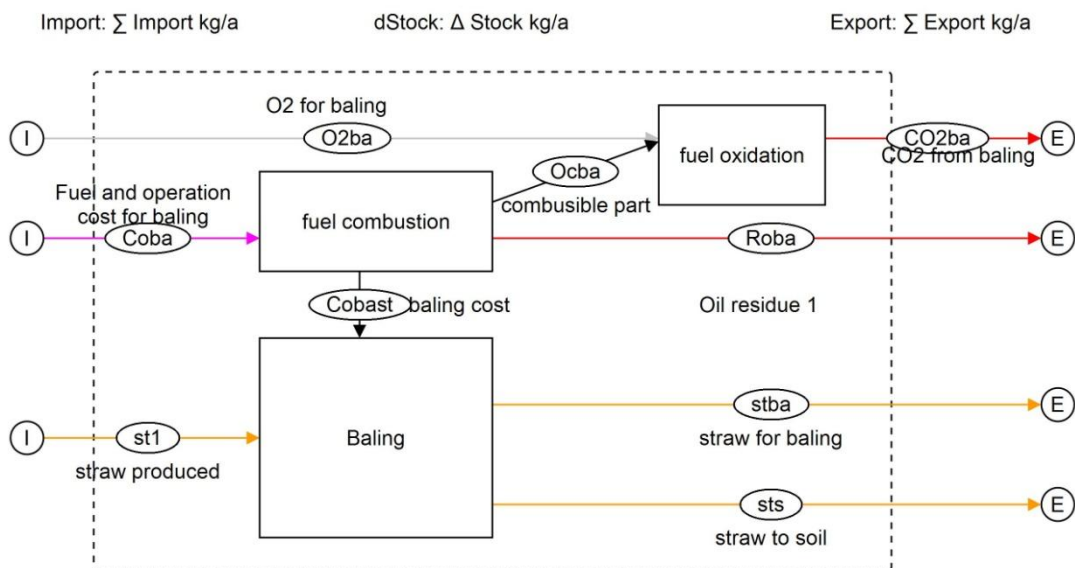

Fig. 3.8. Subsystem Process "Baling"

## B) System Process "Mushroom Cultivation"

Straw Mushroom (*Volvariella* sp. with C 27%, N 4.4%, and P 0.84% DW) cultivation is the process in "Scenario Food" as the only direct food-production from straw. By "basket cultivation" for 14 days/crop, the farmers can harvest mushroom with neither sophistication nor intensive handling. Mushroom is chosen because of a good and constant market value due to permanently high demand on the domestic and export markets.

Mushroom spawn ( $SP_{mu}$ ) consumes substances in straw ( $st_3$ ) to form mushroom's Tissue. Flour (FI) is added in a small amount in order to supply C source for its growth at the initial stage. Spent Mushroom Substrate (SMS) and other gases from catabolism ( $CO_{2mu}$  and  $H_2O_{mu}$ ) as well as  $CH_4$  ( $CH_{4mu}$ ) from straw fermentation by existing natural flora are process residues.

N from Nitrogen sources for mushroom production is the only focal substance. N choices depend on individual decisions by farmers which can be used without costs e.g. from agricultural waste or street plants. It is added in order to control C:N appropriately for mushroom growing. Carbon in supplement food is not calculated as different supplement foods contain various amount of carbon. The model for Scenario food is shown in Fig. 3.9.

The materials utilized, including products and waste from mushroom cultivation are concluded in the concept equation below.

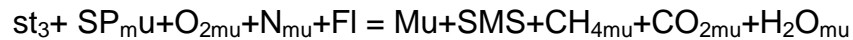

Due to heavy duty permanent use, the mushroom basket ( $B_{mu}$ ) and its plastic cover ( $PI_{mu}$ ), will last for max. 1 year. Therefore, Waste from operating mushroom cultivation ( $W_{cm}$ ) is concluded below.

$$W_{cm} = B_{mu} + PI_{mu}$$

The coefficient of each material is calculated from laboratory analysis and balancing equations at the level of goods and substances, as well as data for  $CH_4$  emissions, as shown in Annex. e.g. experimental data from Lardmahalab (2010), report data from Landschoot and Mcnitt (2015) and Truc *et al* (2013).

The costs in this mushroom cultivation are only the material costs for mushroom and for the operation i.e. baskets and plastic covers, since the farmers and HH members can cultivate the mushrooms by themselves. The costs for materials are listed in Annex. To provide enough containers for the amount of straw used for 1 year, 12 baskets are used for 2 weeks of cultivation cycle. The costs from every year are the same. Therefore:

Total costs = material costs for cultivation + material costs for operation

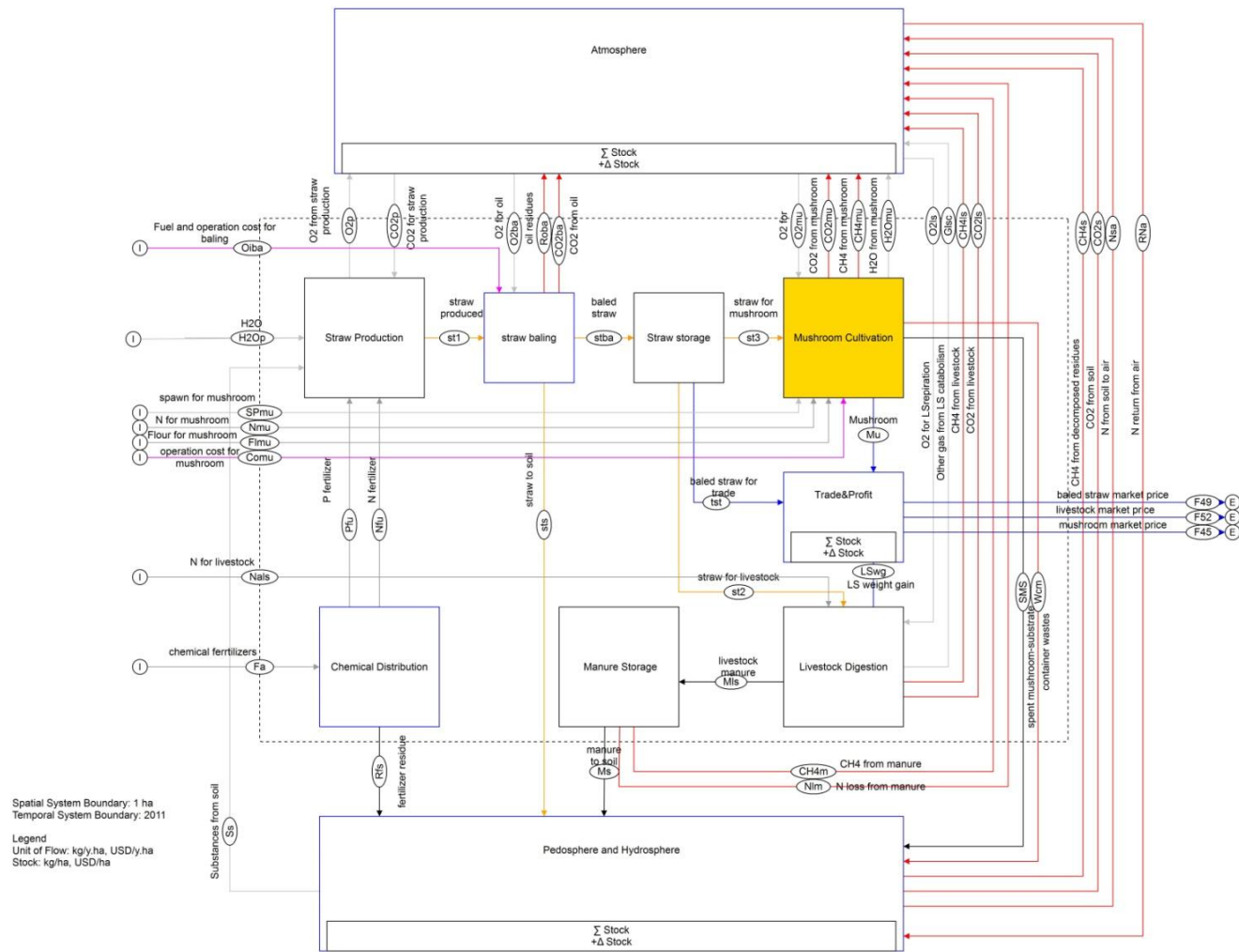

Fig.3.9. MFA per ha in Scenario A "Food" on an exemplary farm in 2011 (no values are shown)

### 3.6.2.2. Scenario B "Fodder"

In Scenario Fodder, baled straw was treated by Urea ( $U_{st}$ ) and lime (CaO) before feeding the cattle. This treatment improves the percentage of N as well as straw's digestibility. The advantage of this scenario is the convenience to feed the cattle at home instead of tethering them around as the cattle can gain weight from straw. Furthermore, farmers can collect the more manure easily for further.

In order to fulfil the task of this scenario, subsystem process "Chemical distribution" and process "Livestock Digestion" are changed as follows:

#### A) System Process "Chemical Distribution" and its subsystem

U-lime unit is added in this existing process from Status Quo as the U-lime treatment also consumes Urea ( $U_{st}$ ) for improving the straw quality on top of the urea normally used as fertilizer for straw production ( $N_p$ ). Part of  $NH_3$  from U-lime treatment is lost to Atmosphere by volatization ( $N_{lu}$ ) while the remaining substances ( $U_{ls}$ ) from urea and CaO from the treatment is mixed with treated straw for feeding cattle.

In order to operate U-lime treatment, 2 concrete pits ( $Ct_c$ ) are constructed in order to treat U lime straw for 3 weeks in parallel. Their size and construction materials needed are based on the model proposed by Suranaree University of Technology (2015). The life-time of these pits is estimated to 10 years. The removable plastic cover ( $Ct_p$ ) holding  $NH_3$  from ureolysis needs to be changed yearly as it will be broken from handling after some time.

The additional equations of material utilized for U-lime treatment are as follows:

$$CaO + U_{st} = U_{ls} + N_{lu}$$

N balance from urea used is concluded in the following equation.

$$N_{Fur} = N_{Up} + N_{Ust}$$

The pit construction needs 2 labourers (Lb). Afterwards, HH members can do the treatment and feed straw to livestock daily by themselves.

The equation of materials spent at the first year of operating U-lime treatment is as follows:

$$Ct_c + Ct_p = \Delta Ct_c + Ct_p$$

Average yearly cost ( $Co_y$ ) for U-lime treatment is calculated from the following equation.

$$Co_y = \frac{(Co_{Ctc} + Co_{Lb})}{10} + Co_{ust} + Co_{CaO}$$

The conclusion of this process in scenario fodder is shown in Fig. 3.10.

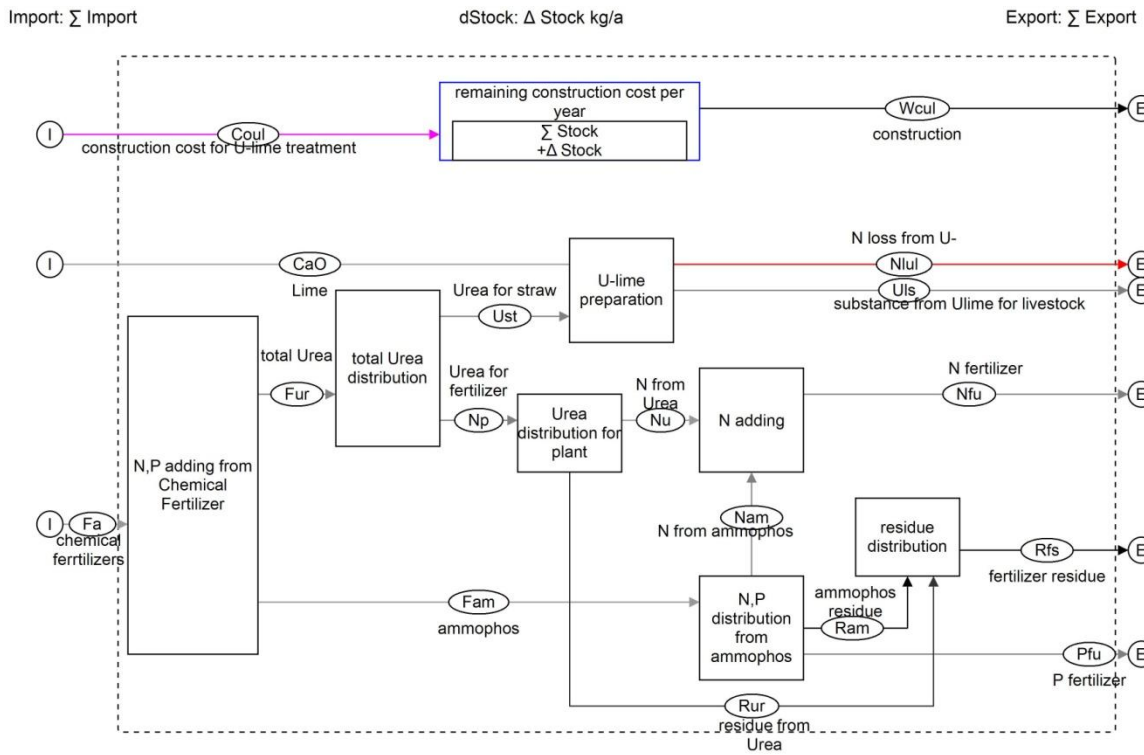

Fig. 3.10. Subsystem of process "Chemical Distribution"



## B) System Process "Livestock Digestion" and its subsystem

In this study, N from plants for livestock feeding is still defined as equal to status Quo. The additional N for this process is from added urea (Fig. 3.11). Process equation, based on that from livestock digestion in Status Quo, is as follows.

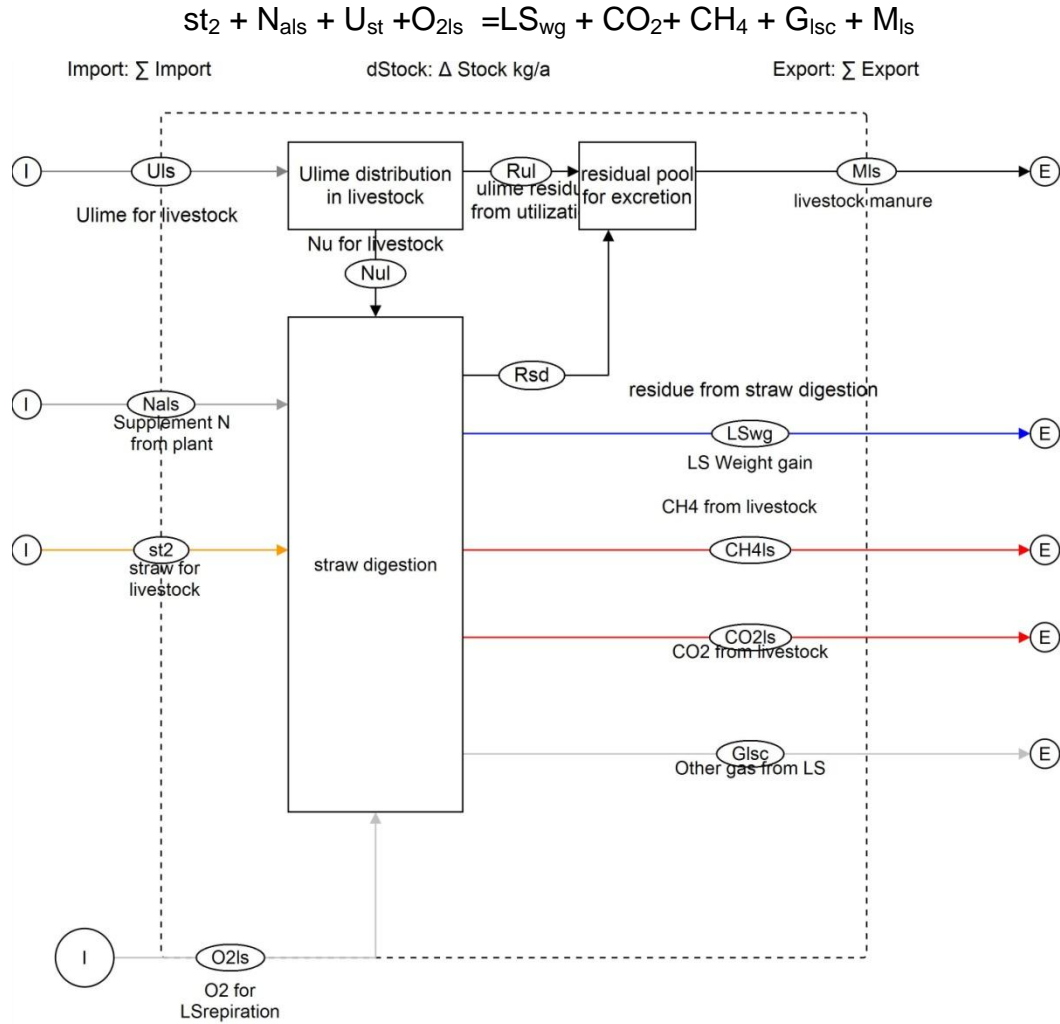

Fig. 3.11. Subsystem of process "Livestock Digestion"

The additional coefficients used in this scenario are from the studies of Jayasuriya and Pierce (1983), including Trac *et al* (2001), as listed in Annex. The model of this scenario is shown in Fig. 3.12.

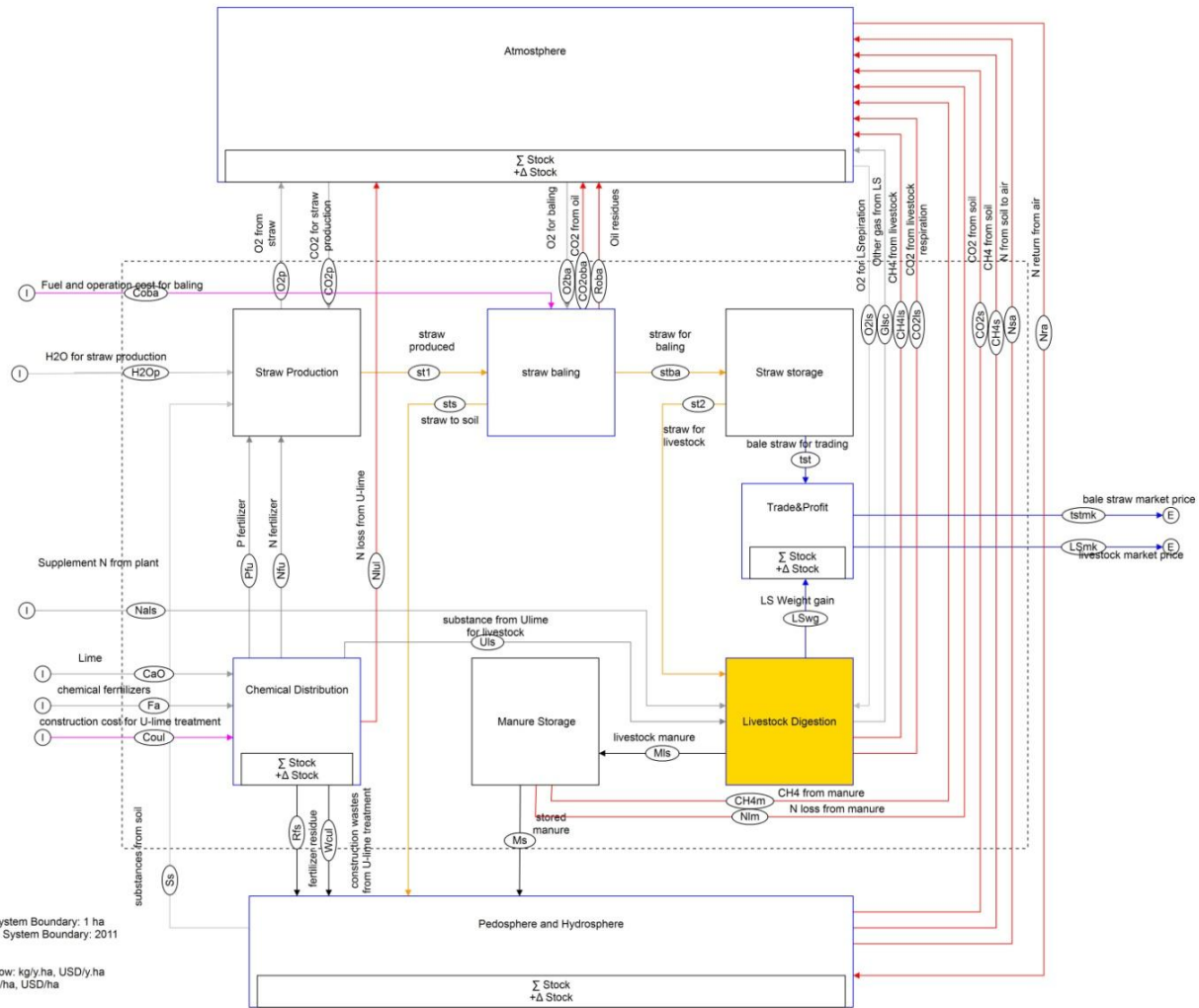

Fig.3.12. MFA per ha in Scenario B "Fodder" on an exemplary farm in 2011 (no value are shown)

### 3.6.2.3. Scenario C "Energy"

This scenario produces energy directly from baled straw by using cattle as a pre-treatment unit to manure, the substrate for biogas production. C in cattle manure is then converted to biogas, the energy product from the biogas digester. Biogas is a chosen product in Scenario Energy as an alternative HH energy instead of LPG which are usually the main fuel cost for HH use. By using biogas, farmers can reduce the cost of fuel consumption.

In order to reduce straw size, adjusting the C:N ratio to around 20:1, as well as increasing the inoculum size of methanogen bacteria in order to improve microbial reaction in the biogas digester, cattle is used as a natural grinder machine in this study as well as a pre-digester to increase the inoculum's size. Furthermore, it is used for digesting straw into more digestible intermediates before fermentation in the biogas digester. Although the cattle is another main source of CH<sub>4</sub>, this simple tool can reduce complexity, being therefore realistic for the farmers to produce energy from small amounts of straw, while gaining additional meat weight as another economic benefit of this scenario.

In this study, the digester is the additional process for producing biogas from cattle manure on top of scenario B "Fodder", as shown in Fig. 3.13. Biogas for small-farm scale is produced in a plug-flow digester made from a PVC bag that DEDE (Thailand) developed from a Taiwanese model. This digester is chosen for farmers thanks to its easy installing, and low-costs. The basic biogas reservoir is made from 2 plastic tanks, normally installed for small farms and HH uses in rural areas, see the example model from DEDE (Thailand). Manure is regularly fed as an input flow into the digester. The retention time for digesting manure in this digester is 21-30 days. Biogas (Bg) from and digester slurry (Sb) are the outputs of this process. Biogas produced relates to Biogas Yield (Y<sub>bg</sub>) and the fraction of volatile solid (VS) in the manure.

The process equation of the digester is as follows.

$$\text{Manure (M}_{\text{Is}}) = \text{Biogas (Bg)} + \text{digester slurry (Sb)}$$

Where  $\text{Bg} = Y_{\text{bg}} \cdot D_{\text{bg}} \cdot \text{VS} \cdot \text{M}_{\text{Is}}$

and  $D_{\text{bg}} = \text{Density of Biogas}$

Following the traditional RSM for manure collecting, the process is used for drying slurry (S<sub>fs</sub>) before collecting it as soil fertilizer. With this process, N produced during fermentation is partly lost to the atmosphere (N<sub>Isl</sub>), mainly NH<sub>3</sub>-N.

N balance at process slurry drying is calculated from the equation below.

$$N_{\text{Sb}} = N_{\text{Sfs}} + N_{\text{Isl}}$$

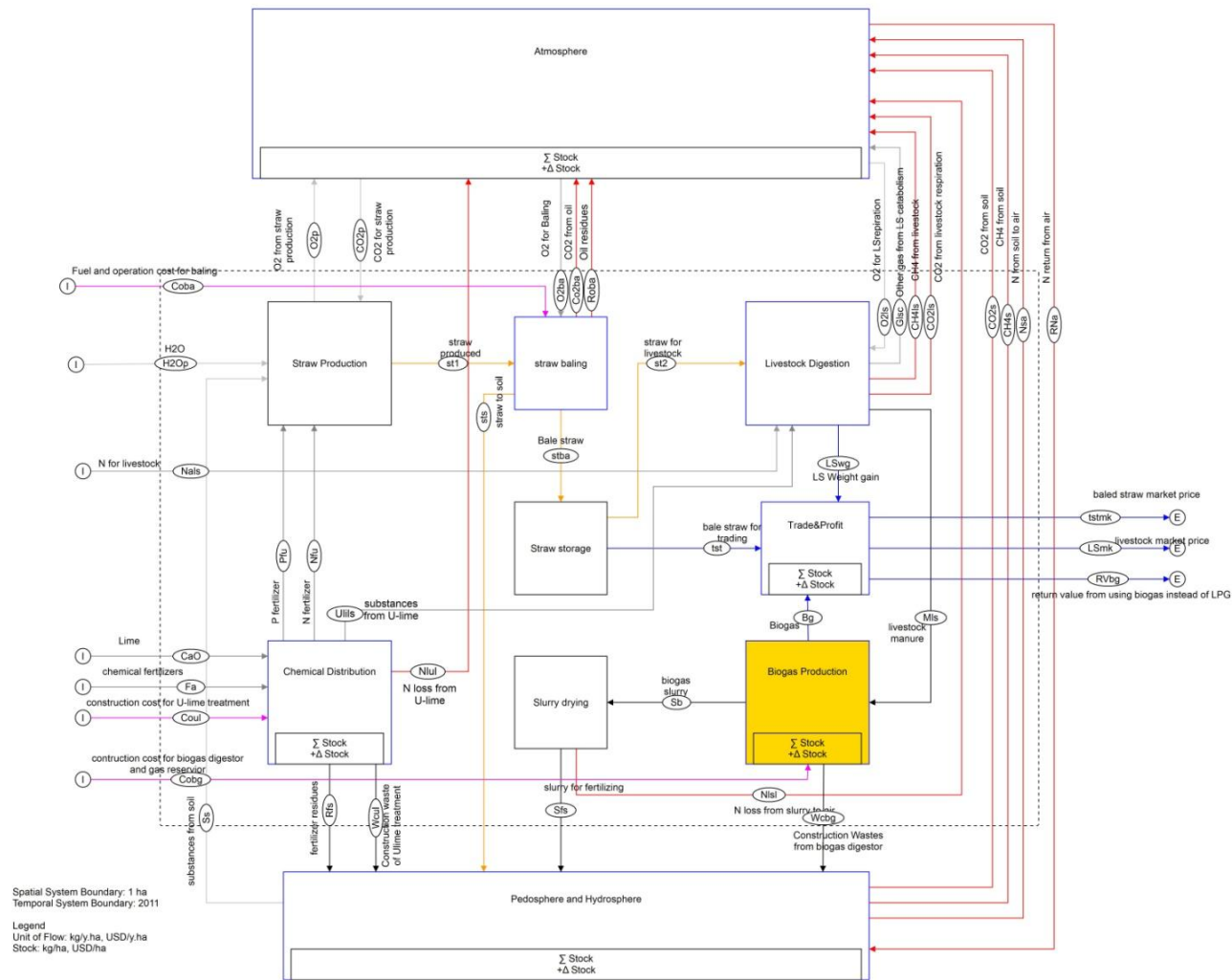

Fig.3.13. MFA per ha in Scenario C "Energy" on an exemplary farm in 2011 (no values are shown)

Total costs in this scenario are from constructing the biogas digester and installing the gas reservoir. The costs are from long term materials ( $LM_{dg}$ ) for 2 concrete pits for manure slurry as the digester's influent and effluent slurry from digester. The duration of the long term materials are defined as 10 years. The short term materials ( $SM_{dg}$ ), e.g. Plastic tube digester, 2 plastic tanks for the gas reservoir, as well as their accessories are defined to last for 5 years.

With this size of digester, a laborer is employed for constructing the influent and effluent pits ( $C_{Lb1}$ ) as well as another one for constructing the plastic digester and gas reservoir ( $C_{Lb2}$ ). Afterwards, HH members can operate the system by themselves.

The average yearly cost for construction are calculated in the subsystem of the process "biogas digester", as shown in Fig. 3.14.

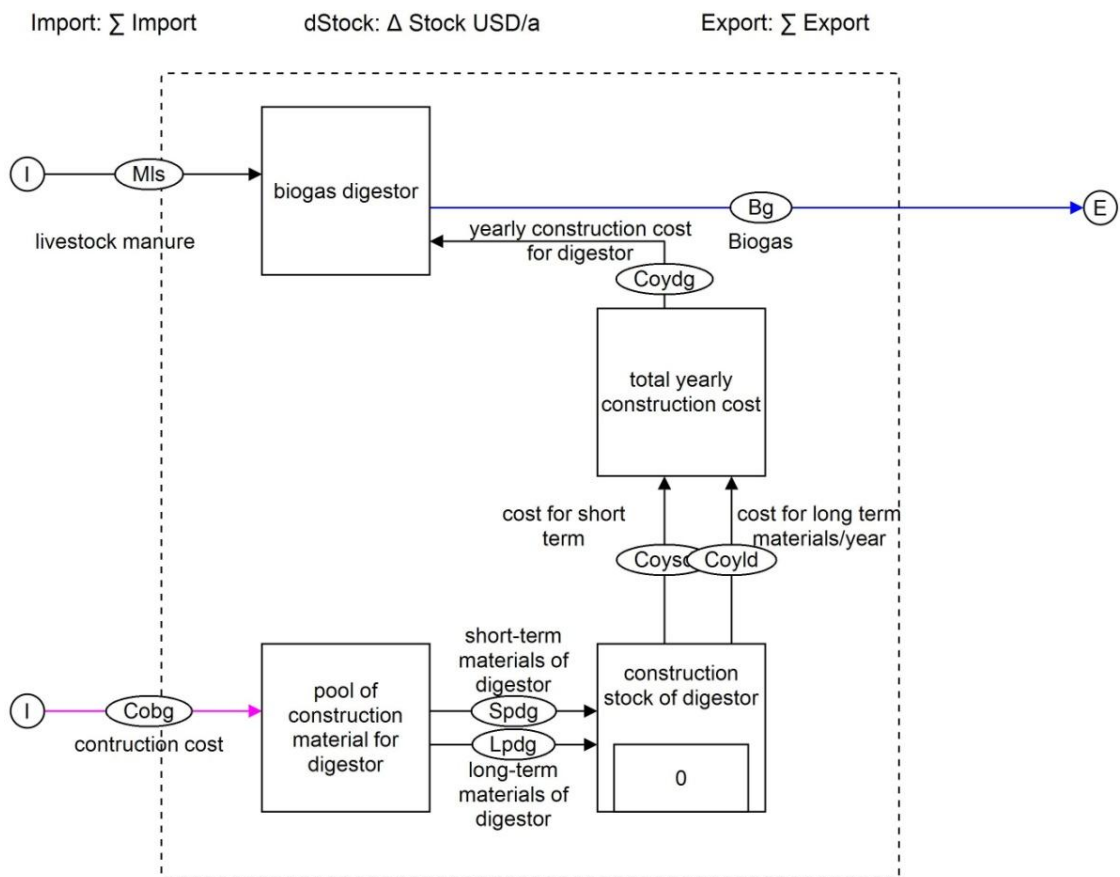

Fig. 3.14. Subsystem of Process "Biogas Digester"

The equation of materials spent at the first year of operating the biogas digester unit is as follows:

$$LM_{dg} + SM_{dg} = \Delta LM_{dg} + \Delta SM_{dg}$$

Average yearly cost ( $Co_{ydg}$ ) for constructing the unit of biogas digester is calculated from the following equation.

$$Co_{ydg} = \frac{(Co_{LTdg} + Co_{LB1})}{10} + \frac{(Co_{STdg} + Co_{LB2})}{5}$$

Economic profit is compared to the return value of biogas HH cooking ( $R_{vbg}$ ) or using in the farm instead of using LPG .It is calculated from conversion factor of energy from biogas to LPG ( $E_{bg/LPG}$ ) and price of LPG ( $P_{LPG}$ ) as follows:

$$R_{vbg} = E_{bg/LPG} \cdot P_{LPG}$$

All parameters and coefficients for calculating in this scenario are based on experimental data from Usack *et al* (2014) as well as reported data e.g. from Joergensen *et al* (2009), Steffen *et al* (1995), as listed in the annex.

#### 3.6.2.4. Scenario Construction

In Scenario Construction, straw brick, a light-weight brick, is produced as a construction material either in small amounts when needed by the farmers themselves or by using simple machines with labourers to produce bigger amounts as this product can also be sold to the market. The advantages of this scenario is not only to allow farmers to gain more income, but that straw brick can trap the substances normally emitted by RSOB to environment.

Materials for producing straw brick ( $BR_{st}$ ) are fine aggregate ( $Ag_f$ ), coarse aggregate ( $Ag_c$ ), straw ( $st_2$ ) and cement Portland ( $cm$ ). Minor part from the production is residue ( $W_{br}$ ). Mass equation of the process is as follows.

$$Ag_f + Ag_c + st_2 + cm = BR_{st} + W_{br}$$

$$\text{number of straw bricks (NBr)} = \frac{\text{total mass of material in straw bricks (BRst)}}{\text{mass straw brick 1 unit (}m_{br}\text{)}}$$

The model of this scenario is shown in Fig. 3.15. Subsystem of process straw brick is shown in Fig. 3.16.

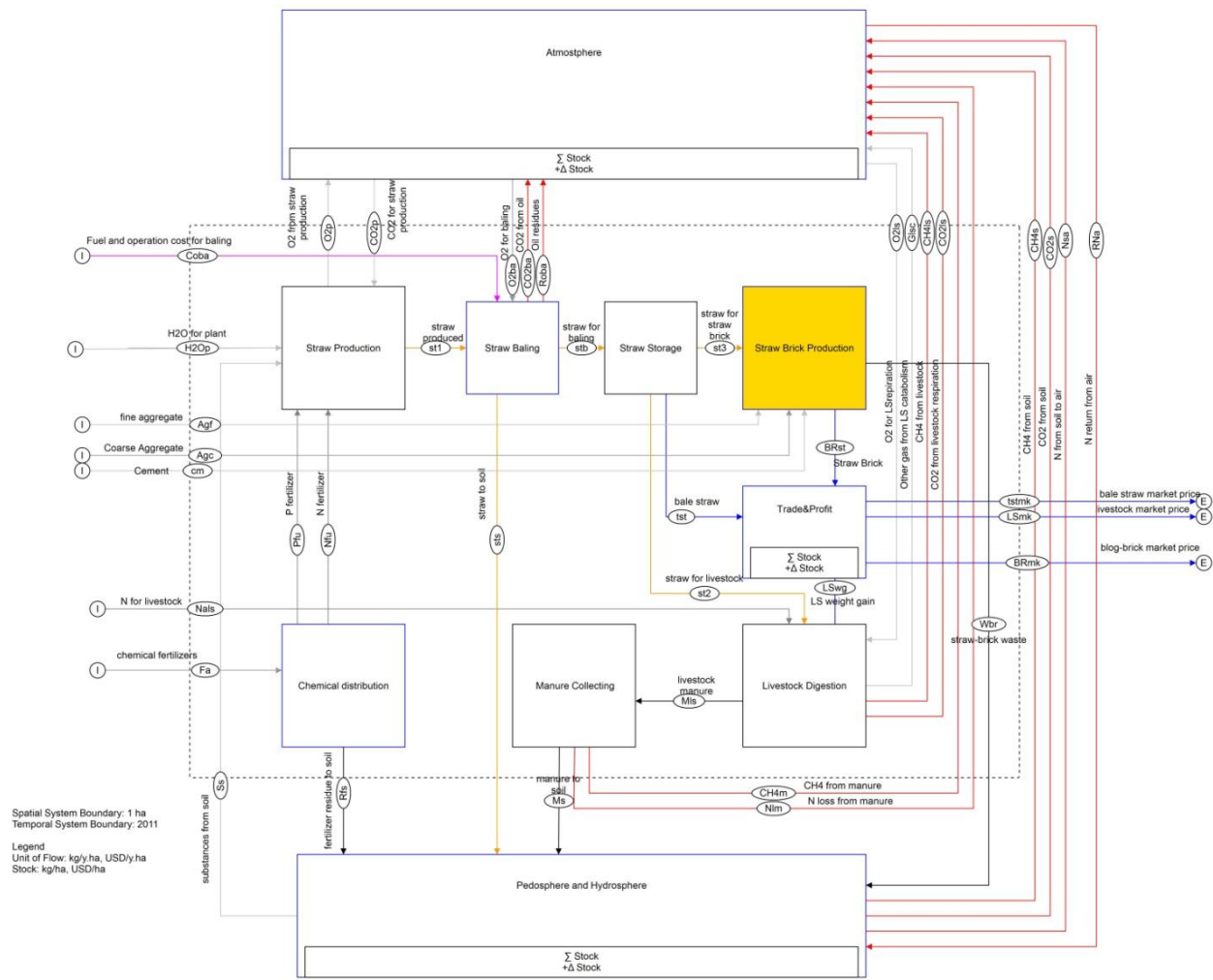

Fig.3.15. MFA per ha in Scenario D "Construction" on an exemplary farm in 2011 (no values are shown)

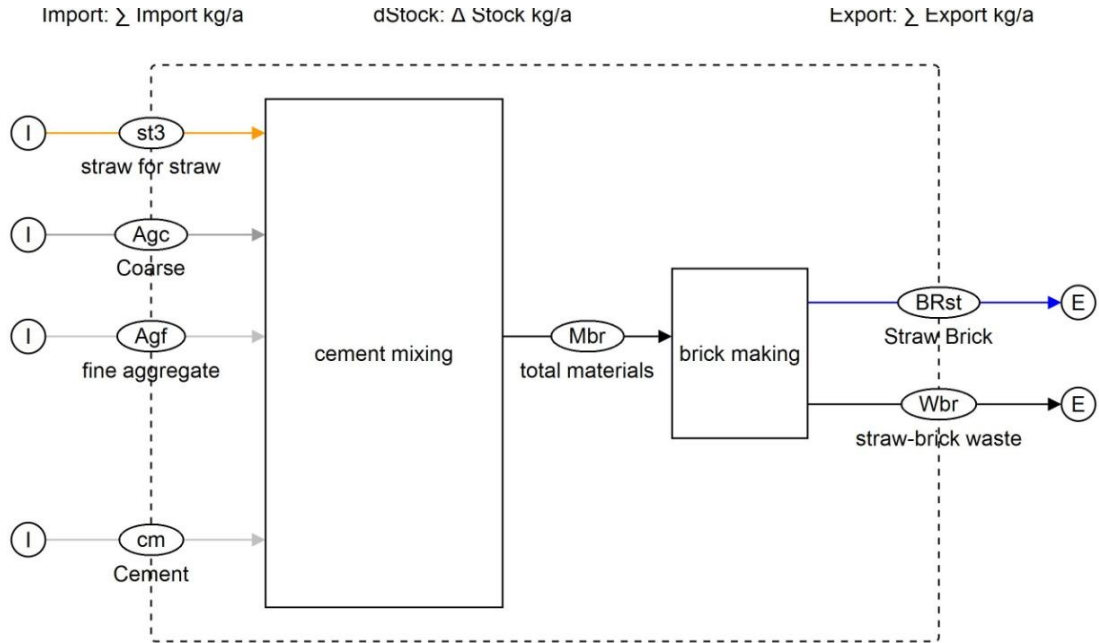

Fig. 3.16. Subsystem of Process "Straw Brick"

As the amounts of straw used as material for straw brick is huge, farmers cannot produced all by themselves. In this study, the model for big scale production is based on a data of Kamwangpruek (2011). Farmers employ labourers and use a brick-producing machine with a capacity of 1000 bricks/day for the community. The number of days for brick production ( $T_{br}$ ) is calculated from the following equation.

$$\text{Number of days producing brick } (T_{br}) = \frac{\text{total mass produced for brick } (MT_{BR})}{\text{mass of 1 brick } (m_{br}) \times \text{machine capacity}}$$

Base on a data of small brick factory collected by Kamwangpruek (2011) to produce straw brick from the big amounts of straw in this scenario, 2 skilful brick makers ( $Lb_s$ ) are employed for chopping straw, mixing materials, and producing bricks by machine. Their fee is calculated per brick per person ( $F_{bm}$ ) while other 2 daily labourers ( $Lb_{dbr}$ ) are used for transferring the bricks to sun-dry followed by collection. 1 truck ( $C_{trbr}$ ) is rented to transfer the machine and products. Electricity costs for the brick machine is also counted ( $Co_{Ebr}$ ). The costs from every year are the same as there is no construction unit. Total costs for producing bricks ( $Co_{br}$ ) are calculated as follows.

$$Co_{br} = (2 F_{bm} \cdot \frac{BR_{st}}{m_{br}}) + 2 (C_{LBdbr} \cdot T_{br}) + Co_{trbr} + Co_{Ebr}$$

All coefficient and conversion factors are e.g. from the study data of Allam *et al* (2011), Kamwangpruek (2011), Srichana and Khwalamtarn (2012) as well as data for material calculation from Council of Engineers (COE) Thailand, (2010), as listed in the annex.



### **3.7. Designing an optimizing a scenario for straw utilization**

#### **3.7.1. Concept of an optimized scenario**

An "Optimized Scenario" is designed to optimize a combination of technologies from the improved scenarios above to optimize economic profit while minimizing negative impacts on the environment as well as to avoid a system failure and the economic risks from producing only a single product from one scenario analysis.

Most of the equations in each process of "Status Quo" except RSOB are equal to keep the system behavior in the optimized scenario unchanged. MFA, SFA, and EA are studied under the same criteria of Status Quo and Scenario analysis. The additional equations, materials input flows, output flows as products and waste, costs, and profits stem from supplementary processes from every scenario i.a. mushroom cultivation, straw treatment as feedstock, biogas digester, and straw-brick production.

Data input as well as temporal and spatial system boundaries of scenario analysis are still equal to those in Status Quo. As the optimized scenario has various processes for the farmer to handle, the amount of materials for construction and operation of each unit are adjusted to the size of straw used for the most effective production. Model effectiveness of the optimized scenario is compared to that of Status Quo, by using the indicators mentioned in paragraph 3.4.

The substance analysis of materials and waste from the construction and operation in this scenario are not counted due to the same reasons as those in scenario analysis.

The model of optimized scenario is shown in Fig. 3.17.

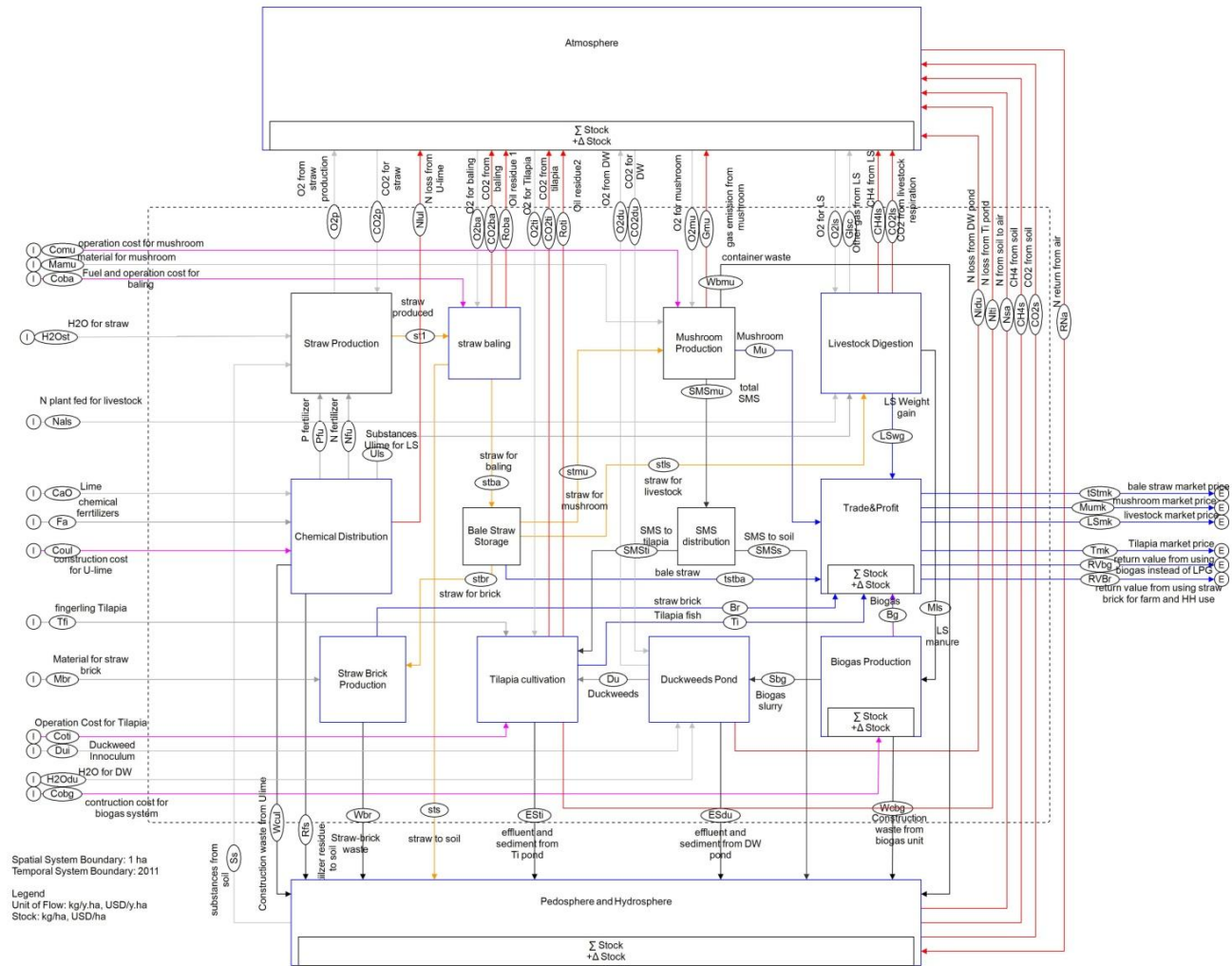

Fig.3.17. MFA per ha in optimized scenario on an exemplary farm in 2011 (no values are shown)

### 3.7.2. Adjusting of the existing processes from Status Quo and improved Scenarios

Following the criteria for realistic and effective production by unskilled farmers as well as minimizing of costs, the proportion for using of straw normally burnt by RSOB in Status Quo is used as different amount of substrates for the following methods:

#### 3.7.2.1. Producing 8 baskets of straw mushroom every 2 weeks

The material costs of the baskets for mushroom operation in this scenario is reduced from 12 basket/y. to 8 baskets/year.

#### 3.7.2.2. Producing 20 units of straw brick per year

Straw brick should be only minimally produced in order to avoid the risk from labour cost which is the main cost of scenario construction. These amounts are for HH and farm maintenances, and storing some as stock brick when needed.

In this production scale, labour and electricity costs for straw brick production is defined as 0 since small amounts of brick can be produced by manual brick template and do not need skilful labour or daily labour. This process can be completed in 1-2 days.

#### 3.7.2.3. Producing U-lime straw for feeding cattle

As straw is divided for several uses, this unit is then smaller. Therefore, it does not need the pits for administering the U-lime treatment as straw can also be wrapped in plastic sheets as an alternative method suggested by the Thai Ministry of Agriculture. Therefore, the cost for concrete and labour for construction in the initial equation of that process are defined as 0.

#### 3.7.2.4. Producing biogas from cattle manure

Referring to paragraph 3.7.2.3. above, the amount of manure from straw digestion is also reduced. The total volume of the biogas digester ( $V_{bd}$ ) is calculated from the following values: the fraction of volatile solid (VS) in manure (M<sub>is</sub>) from cattle produced in 1 year, the dilution factor ( $df_{msl}$ ) of water to dilute Volatile solid in manure slurry at 15-20%, density of manure slurry ( $D_{Msl}$ ), fraction of Volume of manure slurry per total volume of digester ( $V_{msl}$ ), as well as retention time (Rt) of manure slurry fermented in the digester. The equation is as follows.

$$V_{bd} = \frac{M_{is} \cdot VS \cdot df_{msl} \cdot Rt}{365 \cdot D_{Msl} \cdot V_{msl}}$$

From the calculation, A suitable example for this size of production is a 200 l plastic tank digester, based on the models developed in Thailand and India e.g. Panpradist and Ruenreungjai (2006) from Kasetsart University, Kerdme *et al* (2012), Gupta *et al* (2012). The duration of these materials is defined as 5 years due to the plastic structure. The construction costs is based on reports of the maximum costs of materials and labour to install the pilot model at Council Song Peenong's community (2015), Thailand.

### 3.7.3. The additional Processes for optimized scenario

In order to optimize the scenario's effectiveness, system process "Duckweeds" was added in this Scenario in order to trap volatile Nitrogen from digester slurry, followed by Tilapia fish in process "Tilapia" converting substances in the duckweed into fish tissue hence reducing waste emissions while growing fish.

#### 3.7.3.1. System Process "Duckweeds" and its subsystem

Duckweeds (*Lemna* sp. C 37%, N 6.1%, P 1.4% DW) is used in this scenario in order to fix NH<sub>3</sub>-N and P from Digester slurry (S<sub>bg</sub>) into its tissue instead of using algae for reduced risk of oxygen depletion in the pond as well as for easier handling.

Duckweeds inoculum (Dui) which is added into the pond converts C from CO<sub>2</sub> by photosynthesis, as well as N, P, and other substances from digester slurry (S<sub>bg</sub>) to produce its tissue (Du). Part of N is volatilized from duckweeds pond (N<sub>ldu</sub>), while the remaining is still in the water and sediments of the ponds. These remaining substances (ES<sub>du</sub>) from digester slurry in the water pond are drained in order to clean the pond at the end of each cultivating year. Sediments from the pond is put as fertilizers on the paddy field before the next cultivation year. Therefore, the stock of substances in the pond is defined as 0. Retention time (R<sub>tdu</sub>) for cultivating duckweeds is only 3 days before harvesting. For daily harvesting, duckweeds in one third of the pond can be harvested and allow the growth duckweeds in the remaining area to reach maximum growth before harvesting.

Based on Photosynthesis reaction and material balances, process equation of main substances and N balance for Process duckweeds (Du) is as follows:



N distribution in this duckweed ponds is concluded as follows:

$$\text{N}_{\text{Sbg}} + \text{N}_{\text{Dui}} = \text{N}_{\text{Du}} + \text{N}_{\text{ldu}} + \text{N}_{\text{ESdu}}$$

The subsystem of this process is shown in Fig. 3.18.

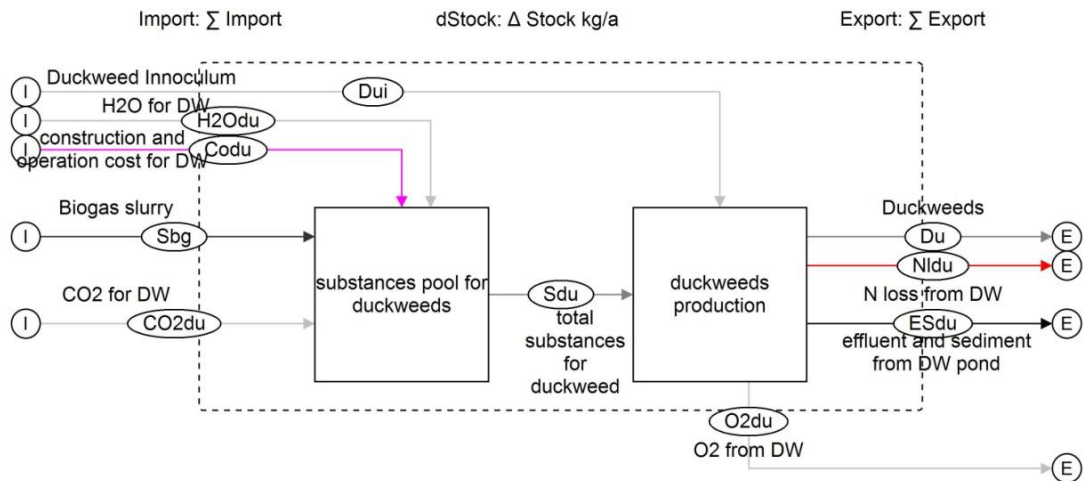

Fig. 3.18. Subsystem of Process "Duckweeds"

Pond's surface area at duckweeds' density  $1 \text{ kg FW/m}^2$ , is calculated from the yearly yield of duckweed DW ( $Du$ ), and mass fraction of Duckweed DW ( $DWdu$ ). The equation is based on data of Leng (1999).

$$\text{pond's surface area} = \frac{Du \cdot Rt_{du}}{365 \cdot DWdu}$$

From this small scale production, farmers and HH members do not need a big pond. They can use existing ponds or setup a 10 cm to 1 m deep pond as well as draining and cleaning the pond by themselves. Therefore, labour cost is 0.

Duckweeds yields and coefficients using in this process are e.g. from the experiment of Rodriguez and Preston (1996), Zimmo (2003) as well as the report from Leng (1999), and Skillicorn *et al* (1993), as listed in the annex.

### 3.7.2.3. System Process SMS Distribution

As amounts of N, Proteins and enzymes in SMS have a potential for fish feeding, SMS is used in this study as a supplement fodder for fish. The amount of SMS as fodder, is based on the amount of OM and straw recommended by the Department of Fisheries, Thailand (DOF, 2015), in order to avoid too much straw substrate accumulation in the pond, as mentioned in Chapter 2. The remaining SMS is used as soil fertilizer. Process equation is as follows.

$$SMS_T = SMS_{Ti} + SMS_{soil}$$

### 3.7.3.2. System Process "Tilapia" and its subsystem

The advantage of this additional process is increasing the capacity for trapping organic C, N, and P from products and waste as fish feed, i.a. SMS (SMS) and Duckweed (Du) by Tilapia (Ti). The Tilapia can also be for HH consumption and sold under high market demand.

Base on N balance, Tilapia fingerling ( $T_{fi}$ ) consumes part of N input into fish tissue ( $T_i$ ). Residues from fish consumption remain in the water and sediment until the fish pond is drained to catch the fish with approx. 500 g FW and clean the pond ( $ES_{fp}$ ). Some N is lost by N volatilization. Water and sediment are used on the farm soil in order to increase soil nutrients. The process equation of Tilapia cultivation is as follows:

$$\text{Total material input} = T_{fi} + Du + SMS = T_i + ES_{Ti} + CO_{2tr} + N_{lti}$$

N from N-fixation in pond is not calculated in this process in order to observe only the yield from only N of wastes produced by RSM. At the same time, data on N balance of Tilapia fish and Tilapia growth from N-fixation is still unclear or imprecise.

With N balance from the equation below, the yield of products and residues from the process are calculated as follows

$$N_{du} + N_{SMS} + T_{fi} = N_{Ti} + N_{ESfp} + N_{lti}$$

The subsystem of process Tilapia is shown in Fig. 3.19.

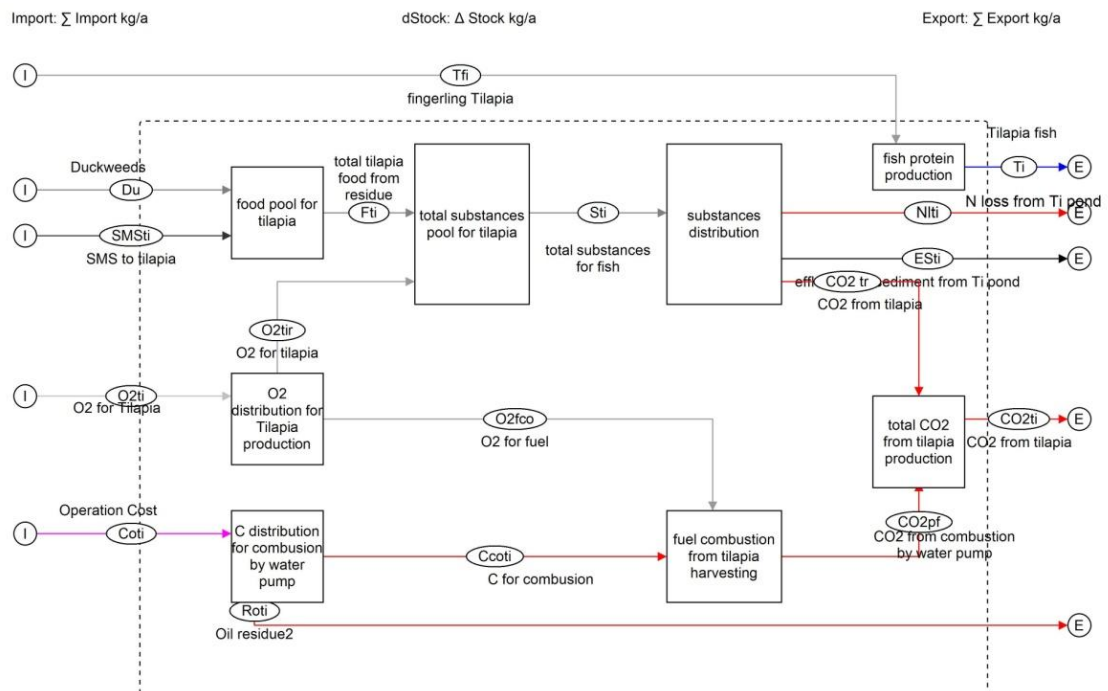

Fig. 3.19. Subsystem of Process "Tilapia"

Farmers can use existing ponds or adjust their size according to the number of fish to cultivate, i.e. 1-3 fish/m<sup>2</sup> pond surface. Farmers need to employ 2 labourers only at the end of the year to harvest the fish and clean the pond for the next round of cultivation. The amount of fuel consumed (O<sub>ti</sub>) for pumping out the water from 1m depth- pond is calculated as follows:

$$O_{ti} = \frac{T_{iN} \cdot P_{u_{cs}} \cdot D_{o_{Ti}}}{R_{fp} \cdot P_{u_{cp}}}$$

where  $R_{fp}$  = ratio of number of fish per pond's surface area (fish unit/m<sup>2</sup>)

$D_{o_{Ti}}$  = fuel density (kg/dm<sup>3</sup>)

$T_{iN}$  = numbers of Tilapia in the pond

$P_{u_{cp}}$  = Pumping capacity (m<sup>3</sup>/h)

$P_{u_{cs}}$  = fuel consumption rate of the pump (dm<sup>3</sup> diesel oil/h)

The calculation of CO<sub>2</sub> emission are same as that from baling process. PM and other pollutants from diesel combustion are not calculated as mentioned before that they are not from direct straw utilization. At the same time, it depends on the diesel and engine type for which precise data do not exist.

Total cost for fish cultivation (Co<sub>Ti</sub>) in this process are the cost from fuel and labourers (Lb). The equation the cost in this process is concluded as follows.

$$Co_{Ti} = Co_{Tfi} + Co_{oil} + Co_{Lb}$$

Data for calculation as from references listed in Annex are e.g. the experiment data from Mueller and Bauer (1996), Knud-Hansen *et al*, 1991, as well as the guideline data from DOF Thailand.

## Chapter 4

### Results and Discussion

#### 4.1. Actual results of MFA for RSM on small farms in Thailand in 2011

##### 4.1.1. Actual results from Status Quo from an exemplary farm

Based on MFA and EA of a traditionally managed farm in 2011 (Status Quo), 3200 kg of straw were produced per hectare of rice farm. With traditional RSM, 27 kg DW or 110 kg FW of livestock were gained from 480 kg of straw. 45 kg of unbale straw was traded. In this traditional RSM, the most crucial as environmentally and health damaging process is RSOB since the air pollutants as well as 54% of total GHG and 85% of CO<sub>2</sub> emissions in this system are generated by the 1500 kg of straw burnt in the field. The pollutants emitted from RSOB are shown in Fig. 4.1. 90% of RSOB's total emissions are CO<sub>2</sub>. The incomplete combustion in this process also produces 5.5% CO, 0.60% CH<sub>4</sub>, and 0.55% PM. Few amounts of N<sub>2</sub>O and NO<sub>2</sub> are also generated as well as other mixed gases and aerosols. Further investigation of these mixtures would require more data for further qualitative and quantitative identifications.

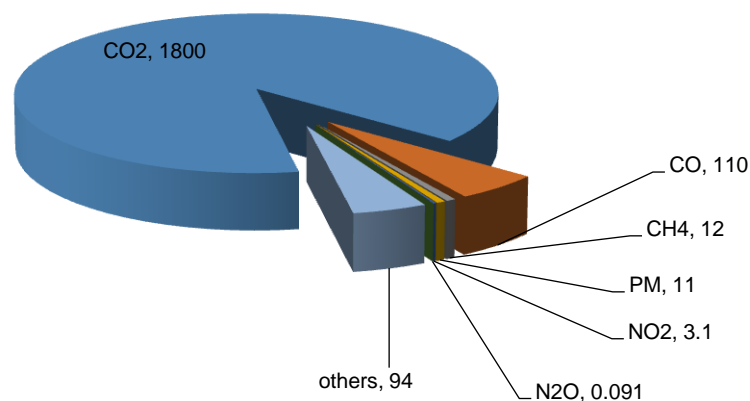

Fig. 4.1. Pollutant emissions from RSOB in Status Quo (kg/y.ha)

The summary of material and substance dynamics from RSM in Status Quo is concluded in Table 4.1.



Table 4.1. Material and substance dynamics per ha from RSM in Status Quo of an exemplary farm in 2011

Indicators		Values	Units
Total substances input for straw utilization	C	1300	kg/y.ha.
	N	41	kg/y.ha
	P	8.5	kg/y.ha
GHG emission		3800	kg CO <sub>2</sub> e/y.ha
CO emission		110	kg/y.ha.
PM emission		11	kg/y.ha.
Substances exported to atmosphere	C	710	kg/y.ha.
	N	15	kg/y.ha.
	P	0.65	kg/y.ha.
Substances exported then accumulate in hydrosphere	C	56	kg/y.ha
	N	9.9	kg/y.ha
	P	1.0	kg/y.ha
Substances exported then accumulate in farm soil	C	510	kg/y.ha
	N	2.8	kg/y.ha
	P	2.4	kg/y.ha
Substances exported in RSM products	C	34	kg/y.ha
	N	4.9	kg/y.ha
	P	0.12	kg/y.ha
Economic profit		130	USD/y.ha

Not only pollutants are generated by RSOB, but residues from the system i.a. left over straw, manure as well as residues from fertilizers are also released to the soil and do partly run off into the hydrosphere. Besides, CO<sub>2</sub> and CH<sub>4</sub> from livestock digestion and soil decomposition are emitted to the atmosphere. MFA, as shown in Fig. 4.2.

The substance flow analysis of C, N, P, and cost and profit for Status Quo are shown in Fig. 4.3-4.6.

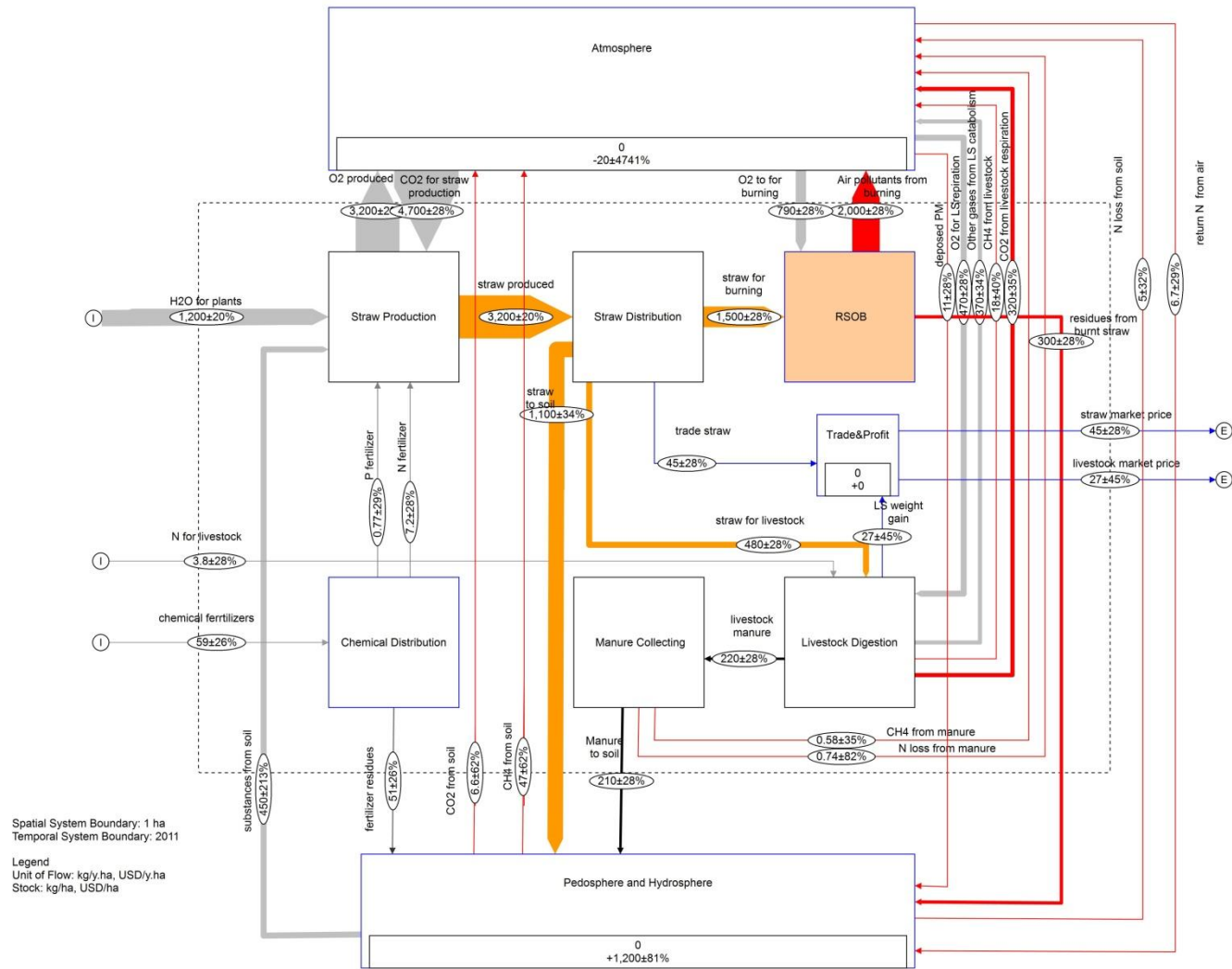

Fig. 4.2. Material flows (Layer Goods) per ha in Status Quo on an exemplary farm in 2011

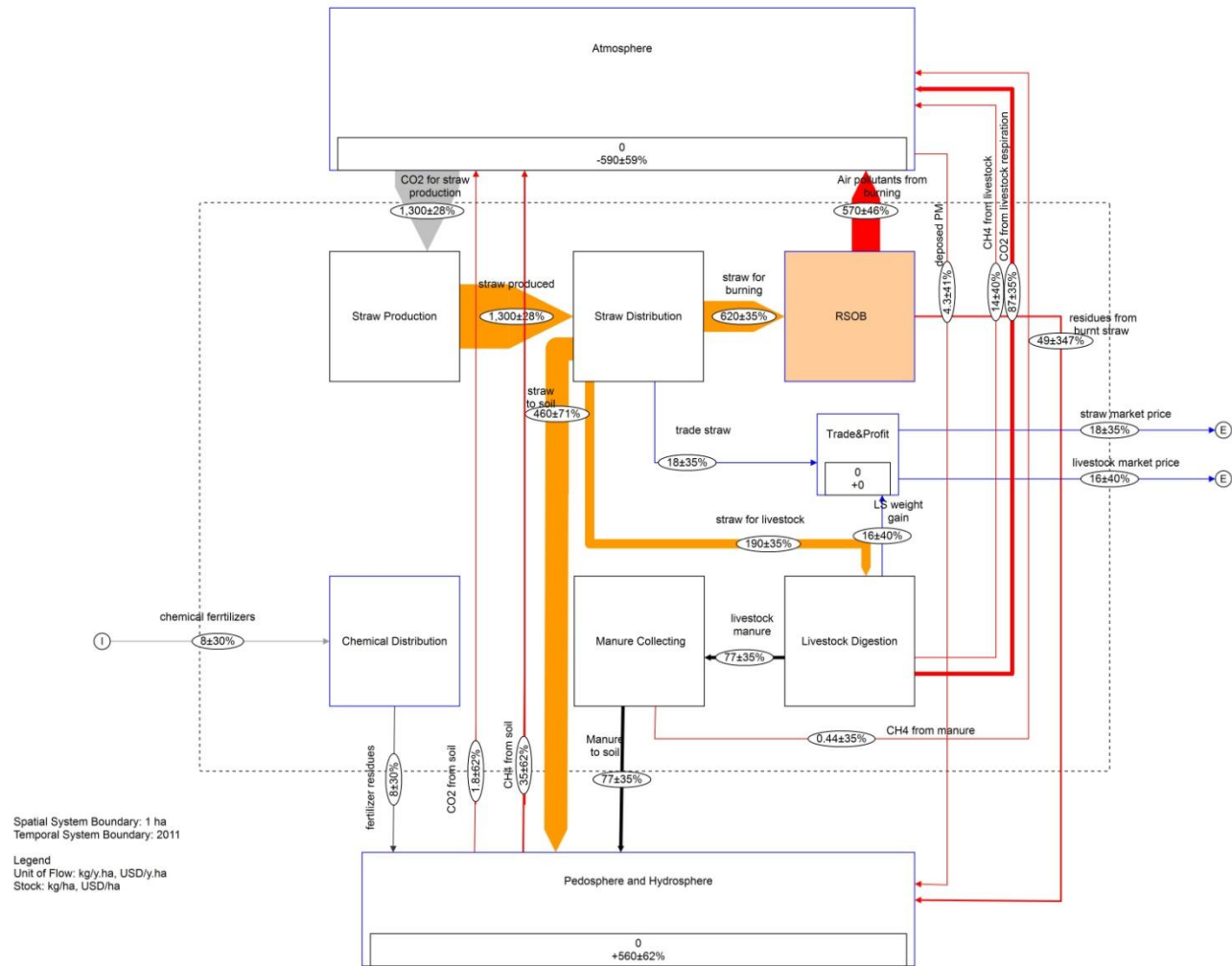

Fig. 4.3. Carbon flows (Layer C) per ha in Status Quo on an exemplary farm in 2011

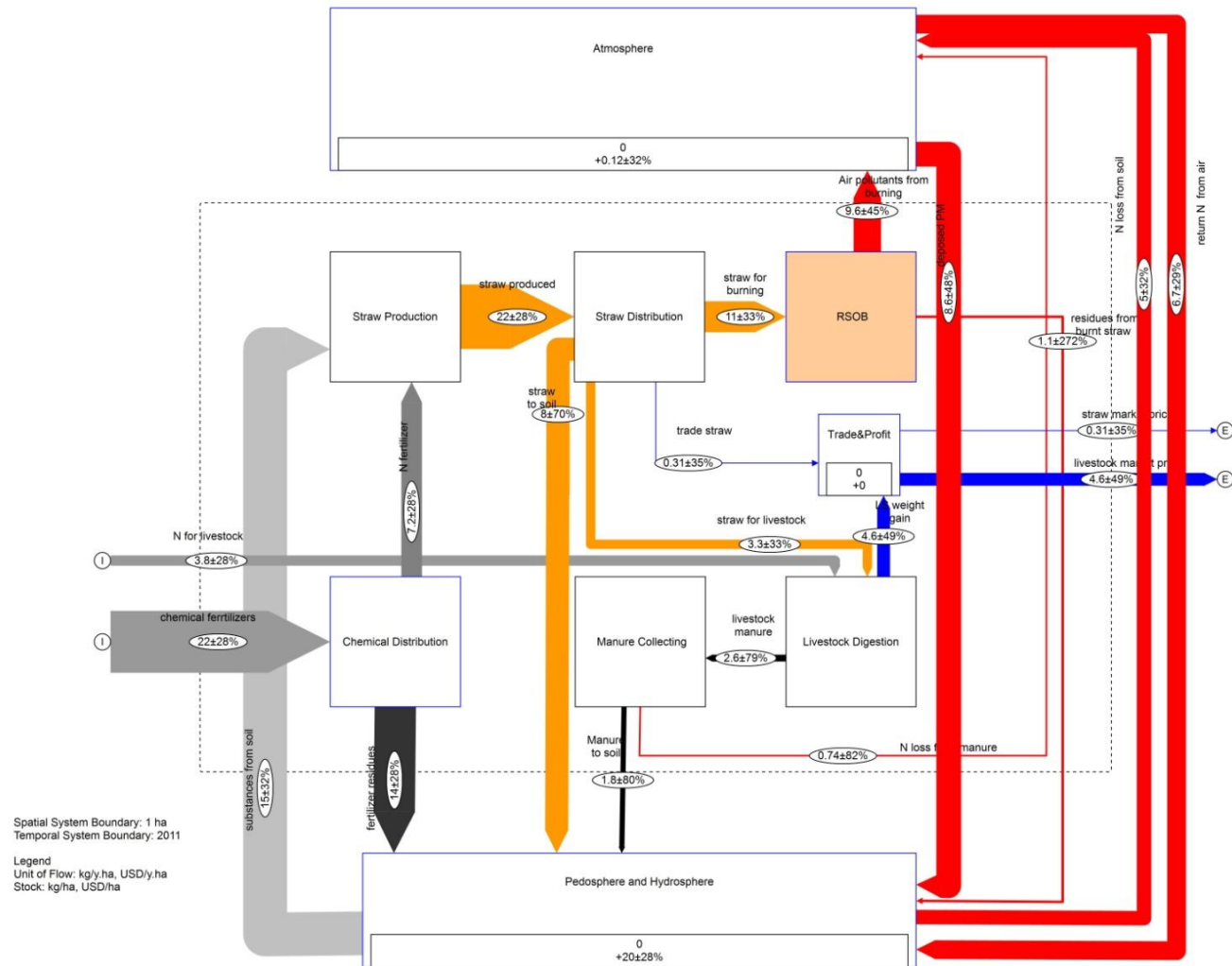

Fig. 4.4. Nitrogen flows (Layer N) per ha in Status Quo of an exemplary farm in 2011

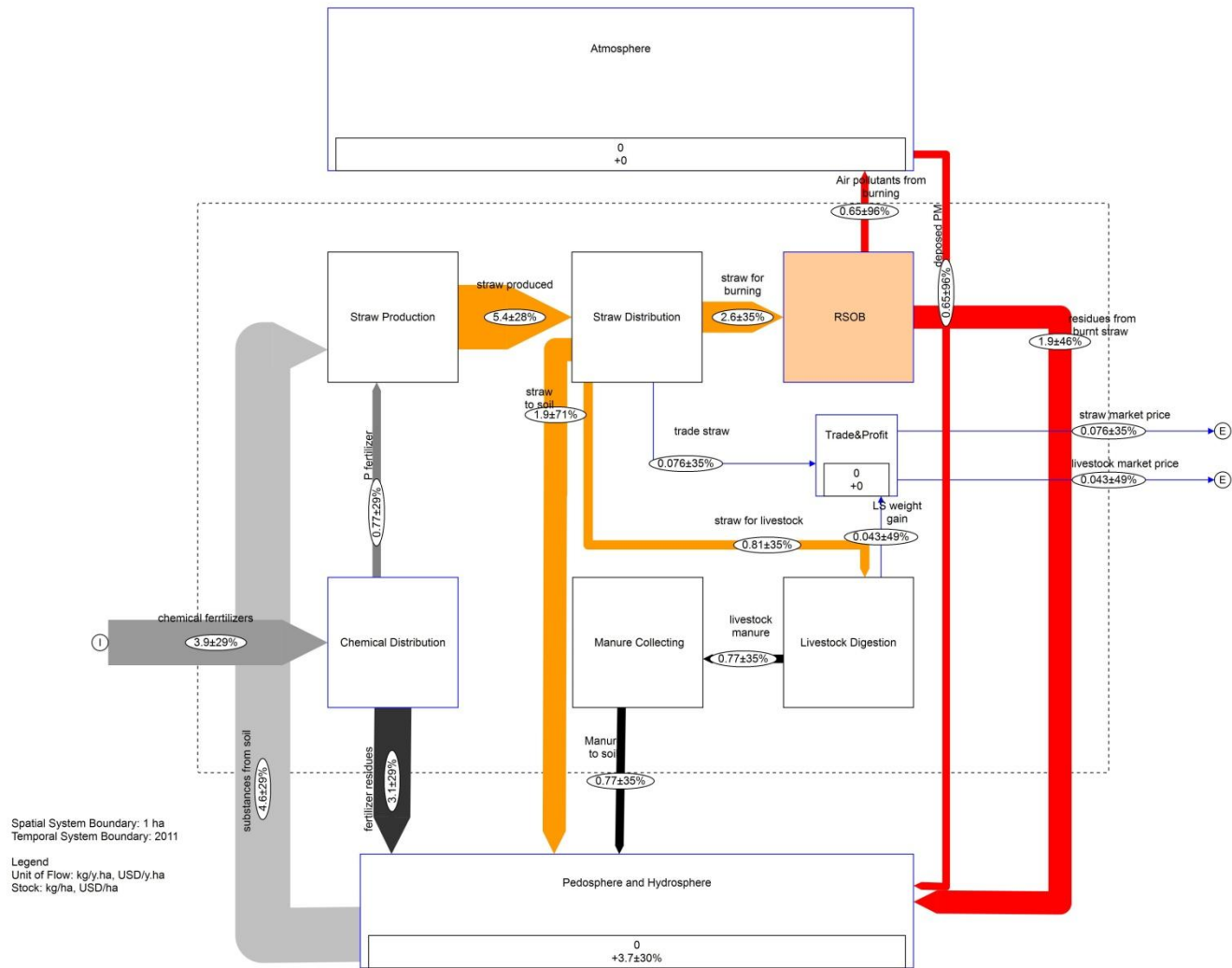

Fig. 4.5. Phosphorus flows (Layer P) per ha in Status Quo on an exemplary farm in 2011

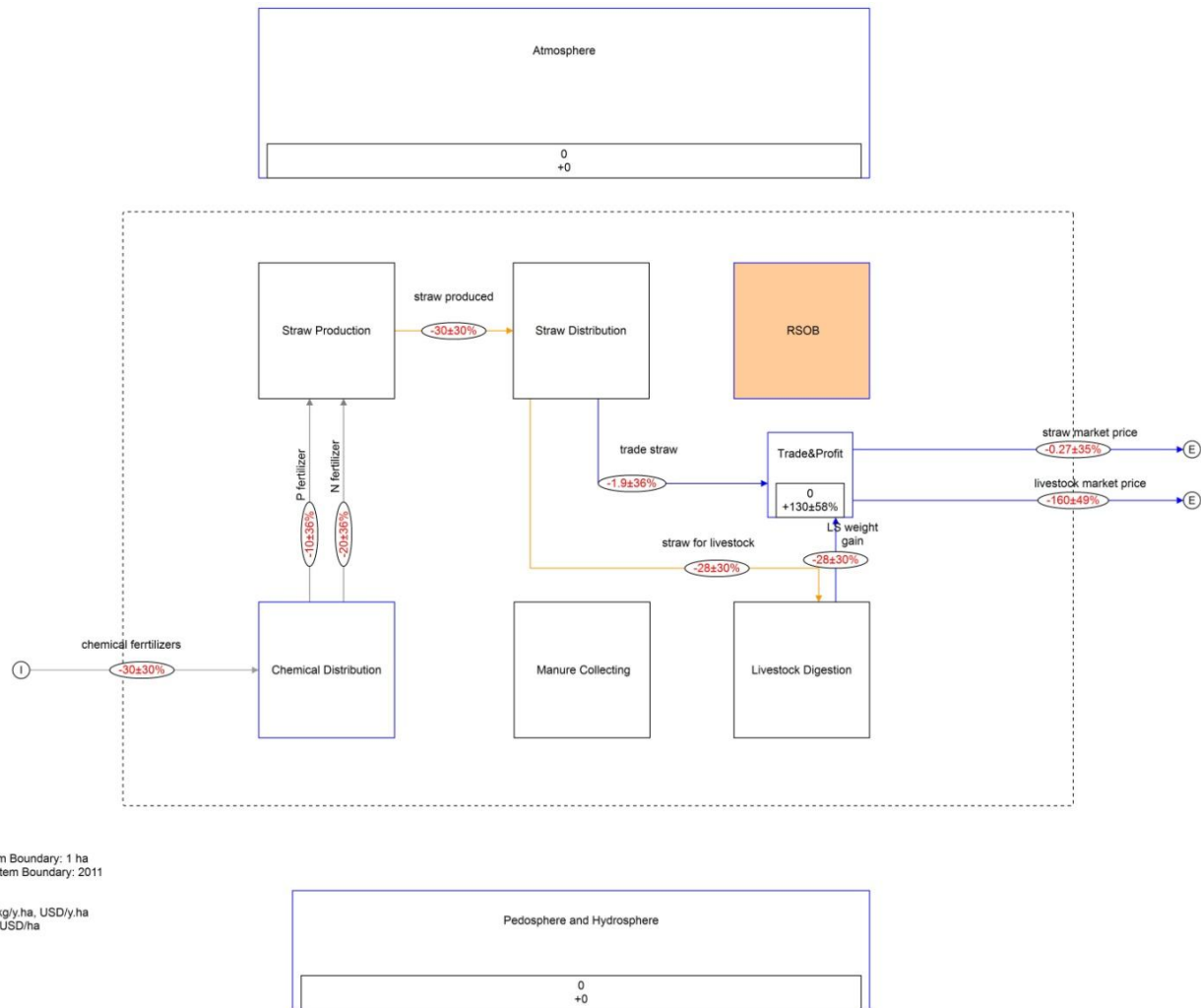

Fig. 4.6. Cost and profit flows (Layer Money) per ha in Status Quo on an exemplary farm in 2011

From SFA, the distribution of C, N, and P from total input are explained as follows:

2.6% of total C input from CO<sub>2</sub> and urea fertilizers are distributed to RSM products. 54% of total C are emitted to the atmosphere, 80% of which are from RSOB only. The remaining C emissions are from livestock digestion as well as from straw decomposition in the rice field. C from manure and fertilizers as well as few remaining amounts from RSOB accumulate in farm soil and the hydrosphere, namely 39% and 4.3% respectively.

12% of total N from fertilizers, from plants in the livestock, as well as from soil input into this system are accumulated in RSM products i.a. livestock weight gain and traded straw. 38% of total N are lost to the atmosphere, 63% of which are from RSOB. The remaining are from N volatilization from waste and soil decomposition. 0.78% of N lost to the atmosphere accumulate as N<sub>2</sub>O in the atmosphere while most of volatile N is deposited back by precipitation to undefined locations of the lithosphere and hydrosphere. The accumulation of N in farm soil and hydrosphere for each year is 6.9% and 24% respectively. The remaining amounts are recycled from soil as plant nutrients.

1.4% of total P input from fertilizers and soil into this system is used for producing RSM products. 7.6% of total P are lost to the atmosphere by RSOB, then deposited back to undefined locations in the lithosphere and hydrosphere. P accumulated in farm soil is from the non-combustible parts of RSOB as well as manure and left over straw. Total accumulations of P in farm soil and the hydrosphere are 28% and 12%, respectively. The remaining amounts of P are recycled from soil as plant nutrients.

#### 4.1.2. Scenario analysis per ha of improved RSM in a small farm

In all Scenarios below, CO<sub>2</sub>, N<sub>2</sub>O as well as total N from farm lost to the atmosphere are reduced. N and P flows to the hydrosphere are reduced as well. Furthermore, PM and CO as well as P emitted directly from straw to the atmosphere are eliminated. Typical products for all scenarios are baled straw and livestock weight gain in the same amounts as those from Status Quo. Typical waste is left-over straw on the field including manure from livestock digestion. The additional substrate materials, products and waste depend on the process implemented in each scenario.

##### 4.1.2.1. Scenario A “Food”

In this scenario (Fig. 4.7-4.10), the additional product is 24 kg DW or 240 kg mushroom FW. Its Spent Mushroom Substrate (SMS) is added as soil conditioner. Farmer’s profit is 570 USD/a. This scenario emits 95 kg CH<sub>4</sub>, mainly from livestock production as well as 1000 kg CO<sub>2</sub> and 0.11 kg N<sub>2</sub>O.

The relevant data of pollutant emissions and substances accumulation are concluded in Table 4.2.

Table 4.2. Material and substance dynamics per ha from RSM in Scenario A "Food" of an exemplary farm in 2011

Indicators		Values	Units
Total substances input for straw utilization	C	1300	kg/y.ha.
	N	40	kg/y.ha
	P	8.1	kg/y.ha
GHG emission		3100	kg CO <sub>2</sub> e/y.ha
CO emission		0	kg/y.ha.
PM emission		0	kg/y.ha.
Substances primarily exported to atmosphere	C	350	kg/y.ha.
	N	7.2	kg/y.ha.
	P	0	kg/y.ha.
Substances exported then accumulate in hydrosphere	C	87	kg/y.ha
	N	6.5	kg/y.ha
	P	0.69	kg/y.ha
Substances exported then accumulate in farm soil	C	820	kg/y.ha
	N	3.6	kg/y.ha
	P	2.5	kg/y.ha
Substances exported in farm products	C	41	kg/y.ha
	N	6.0	kg/y.ha
	P	0.32	kg/y.ha
Economic profit		570	USD/y.ha



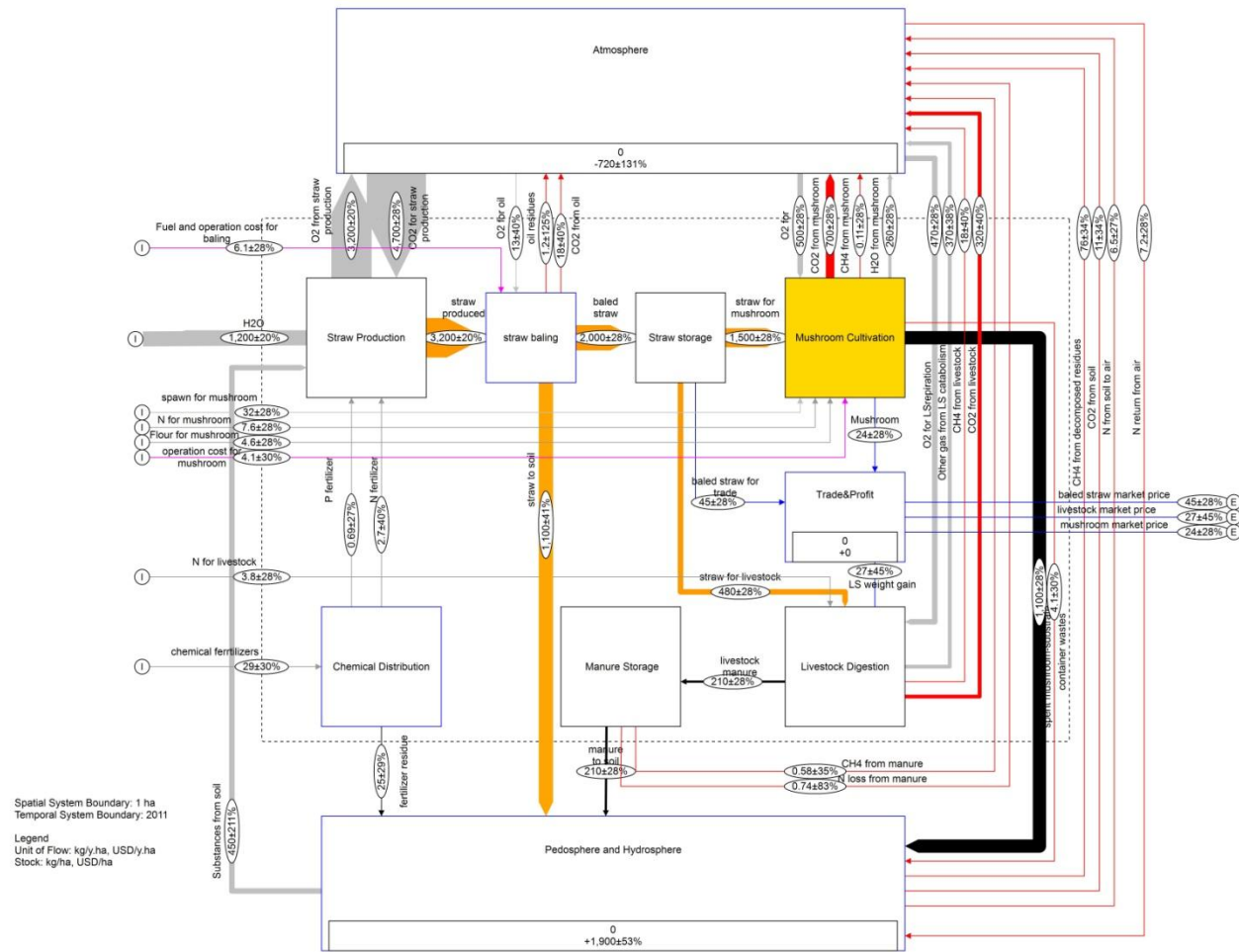

Fig. 4.7. Material flows (layer Goods) per ha in Scenario A "Food" on an exemplary farm in 2011

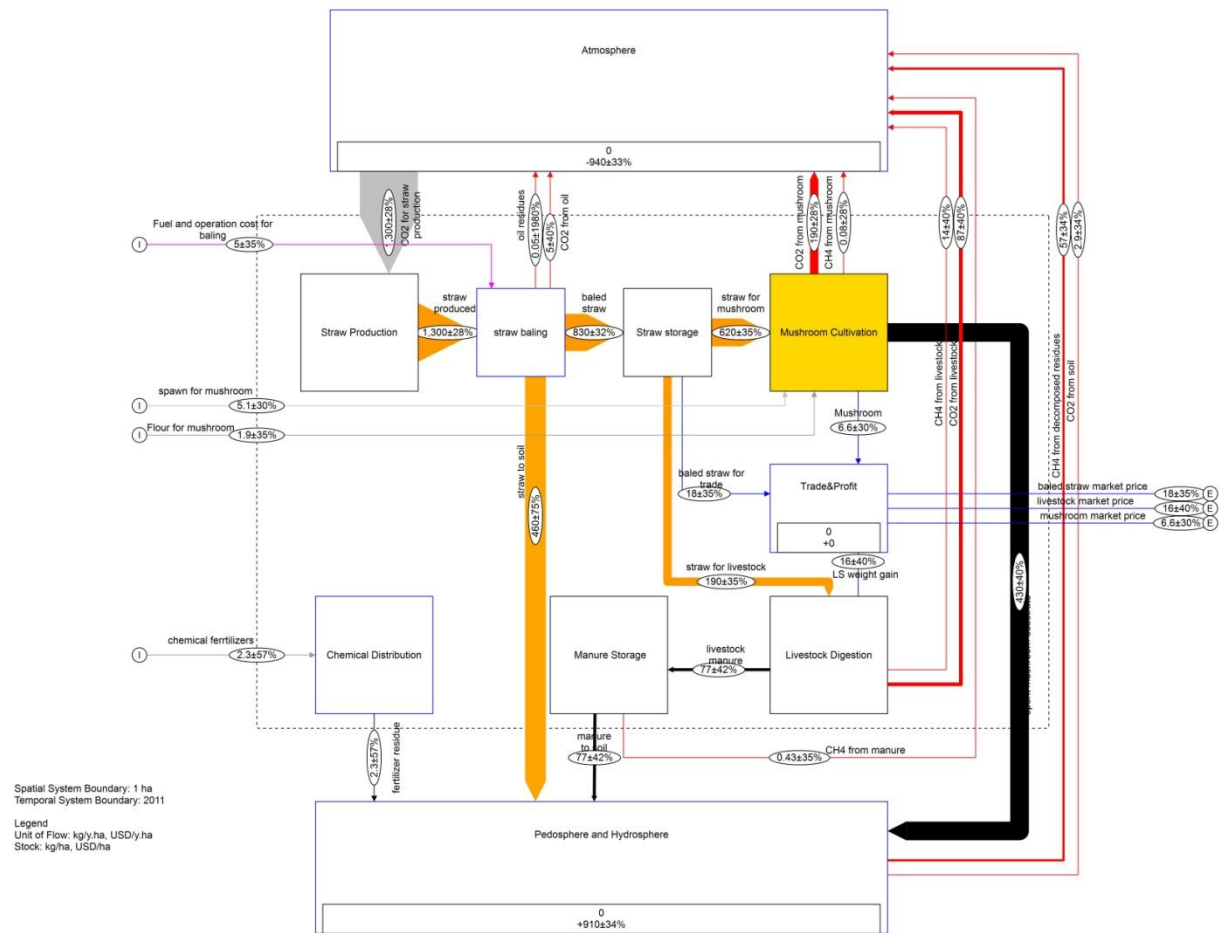

Fig. 4.8. Carbon flows (layer C) per ha in Scenario A "Food" on an exemplary farm in 2011

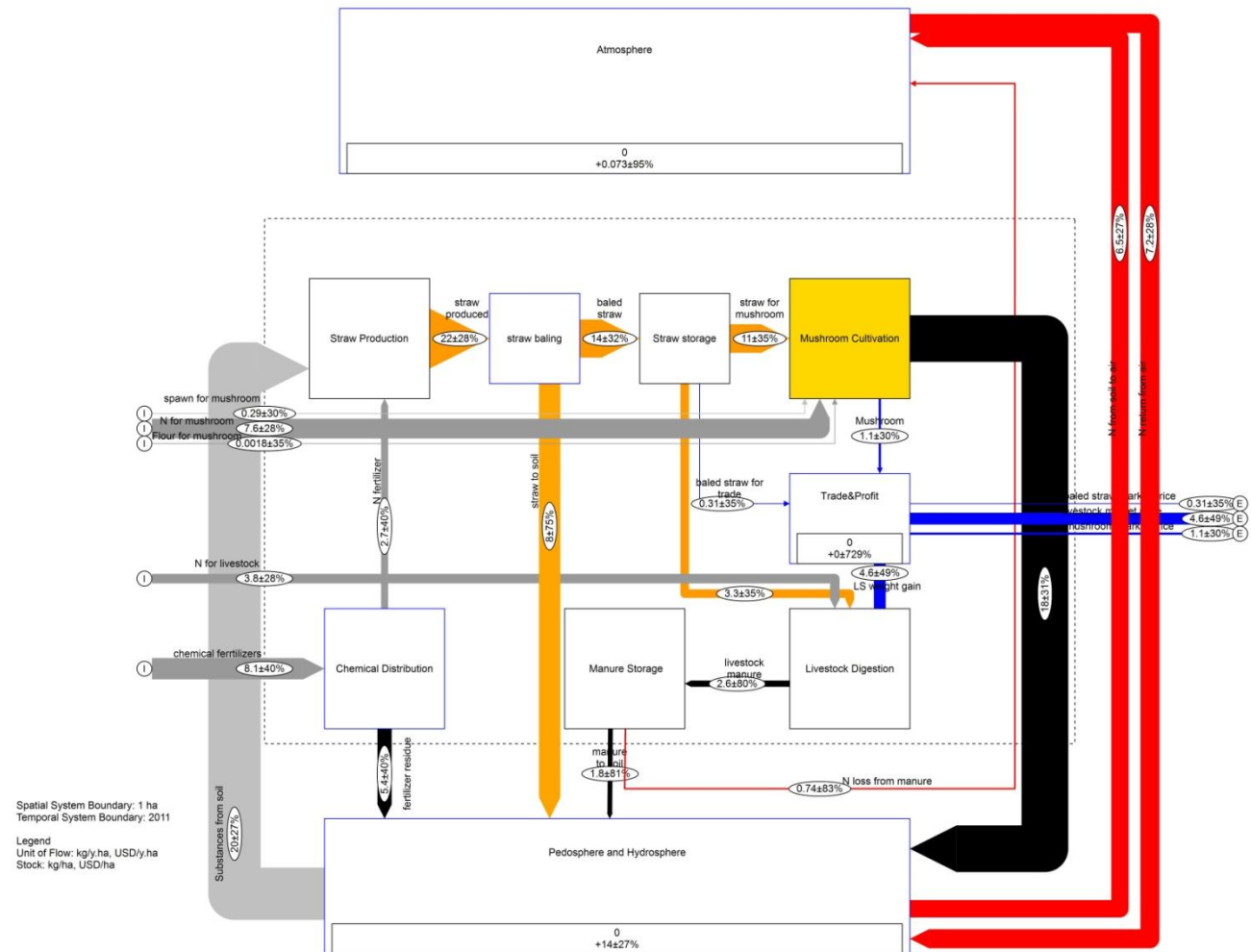

Fig. 4.9. Nitrogen flows (layer N) per ha in Scenario A "Food" on an exemplary farm in 2011

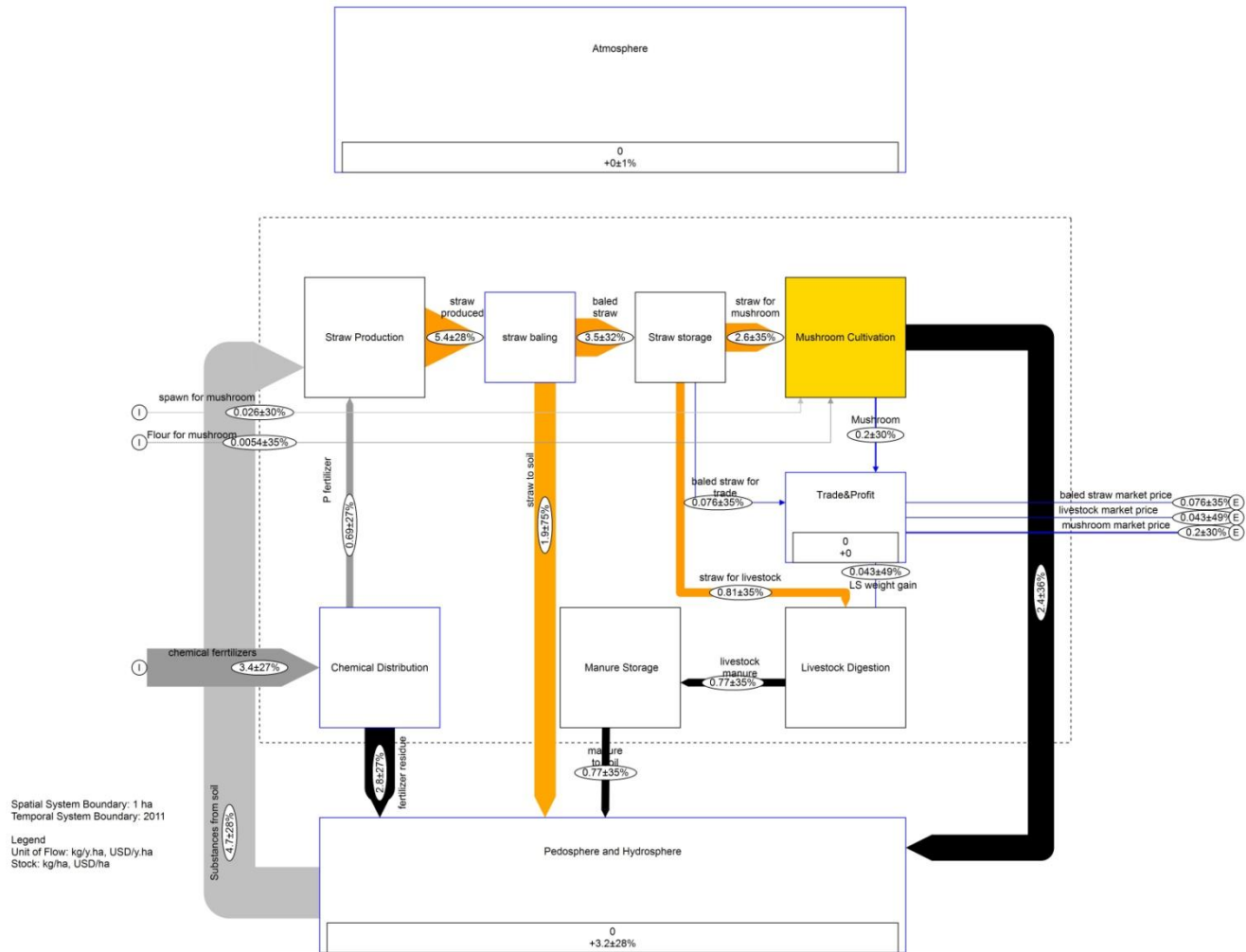

Fig. 4.10. Phosphorus flows (layer P) per ha in Scenario A "Food" on an exemplary farm in 2011

From SFA of scenario food, the distribution of C, N, and P from total input are explained as follows:

3.1% of total C input from CO<sub>2</sub>, urea, and mushroom substrates for RSM utilization are distributed to the scenario's products. In 1 year, 63% of the total C input accumulate in soil. These percentages are from SMS, left-over straw, manure, fertilizers, typical waste and residues (the same as those in Status Quo). 6.6% of total C accumulate in the hydrosphere. 27% of C are emitted to the atmosphere as CO<sub>2</sub> and CH<sub>4</sub>.

15% of total N input from N sources for mushroom utilization, fertilizers, soil, as well as N from plants for livestock feeding, are distributed in the scenario's products. 18% of this total N are emitted to atmosphere via N volatilization from denitrification in soil. 1.0% of the volatilized N remains in the atmosphere as N<sub>2</sub>O while most of N is deposited back to undefined locations of the pedosphere and hydrosphere. The yearly accumulations of N in farm soil and hydrosphere are 9.0% and 16% of total N input, respectively. The remaining are recycled as plant nutrients from soil after the decomposition of waste and residues in soil.

Without losing any P to the atmosphere, 3.9% and 31% of total P input (8.1 kg) from P source for mushroom utilization, fertilizers and soil, are distributed to the scenario's products and soil, respectively. 8.5% of P are lost into the hydrosphere. The remaining P is recycled as plant nutrients from soil after the RSM waste and residues are decomposed.

#### 4.1.2.2. Scenario B “Fodder”

In Scenario Fodder (Fig. 4.11 - 4.14), 83 kg DW out of 110 kg DW (440 kg FW) of livestock are gained additionally from feeding livestock with straw previously burnt in RSOB. Straw is treated by Urea and Lime before feeding. The waste and residues are the same as in Status Quo. Farmer’s profit is 560 USD/a. This scenario emits 140 kg CH<sub>4</sub> from livestock production as well as 1300 kg CO<sub>2</sub> and 0.20 kg N<sub>2</sub>O.

The relevant data of pollutant emissions and substances accumulation are concluded in Table 4.3.

Table 4.3. Material and substance dynamics per ha from RSM in Scenario B "Fodder" of an exemplary farm in 2011

Indicators		Values	Units
Total substances input for straw utilization	C	1300	kg/y.ha.
	N	55	kg/y.ha
	P	8.1	kg/y.ha
GHG emission		4300	kg CO <sub>2</sub> e/y.ha
CO emission		0	kg/y.ha.
PM emission		0	kg/y.ha.
Substances primarily exported to atmosphere	C	480	kg/y.ha.
	N	13	kg/y.ha.
	P	0	kg/y.ha.
Substances exported then accumulate in hydrosphere	C	67	kg/y.ha
	N	8.8	kg/y.ha
	P	0.69	kg/y.ha
Substances exported then accumulated in farm soil	C	680	kg/y.ha
	N	3.2	kg/y.ha
	P	2.5	kg/y.ha
Substances exported in farm products	C	84	kg/y.ha
	N	19	kg/y.ha
	P	0.26	kg/y.ha
Economic profit		560	USD/y.ha

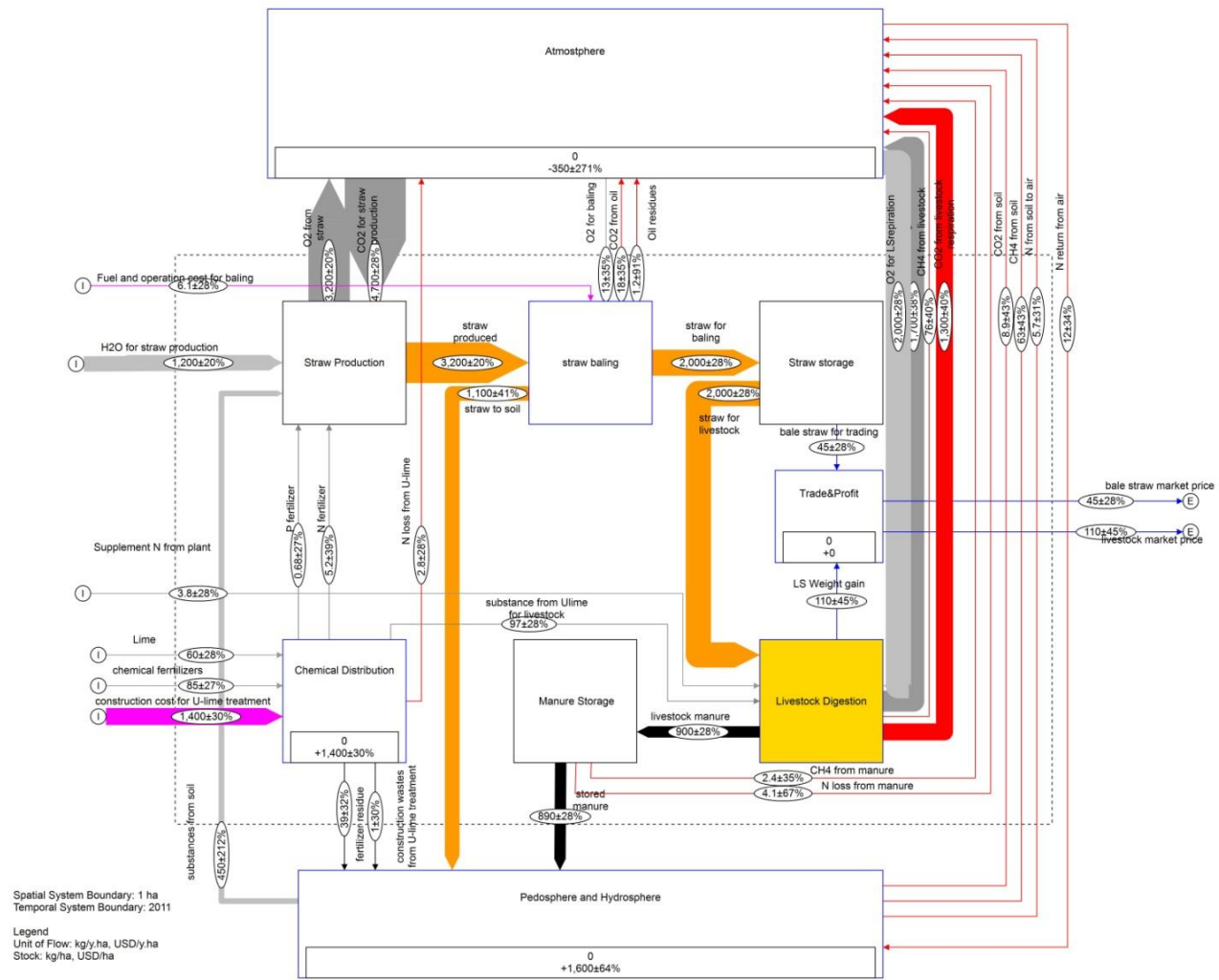

Fig. 4.11. Material flows (layer Goods) per ha in Scenario B "Fodder" on an exemplary farm in 2011

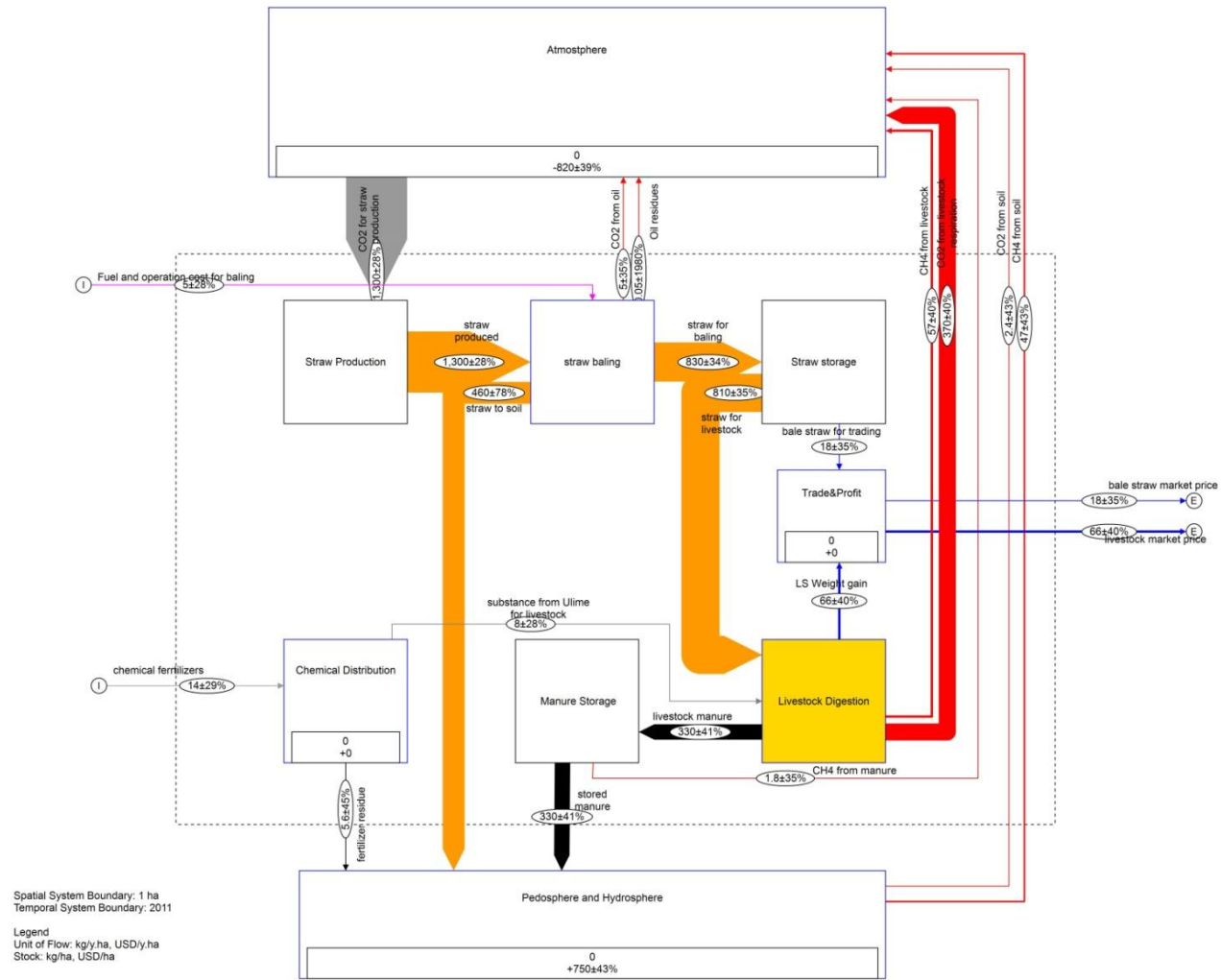

Fig. 4.12. Carbon flows (layer C) per ha in Scenario B "Fodder" on an exemplary farm in 2011



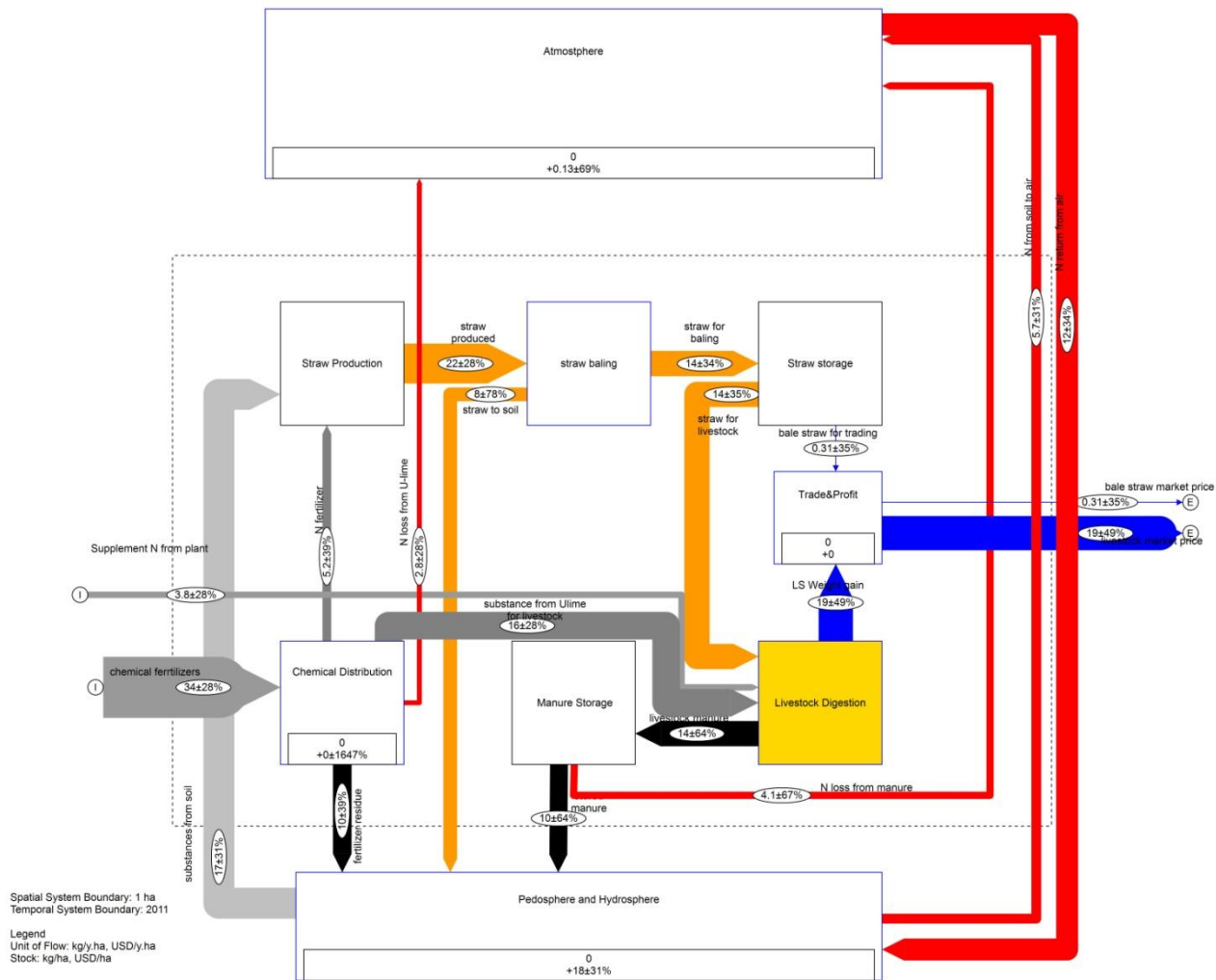

Fig. 4.13. Nitrogen flows (layer N) per ha in Scenario B "Fodder" on an exemplary farm in 2011

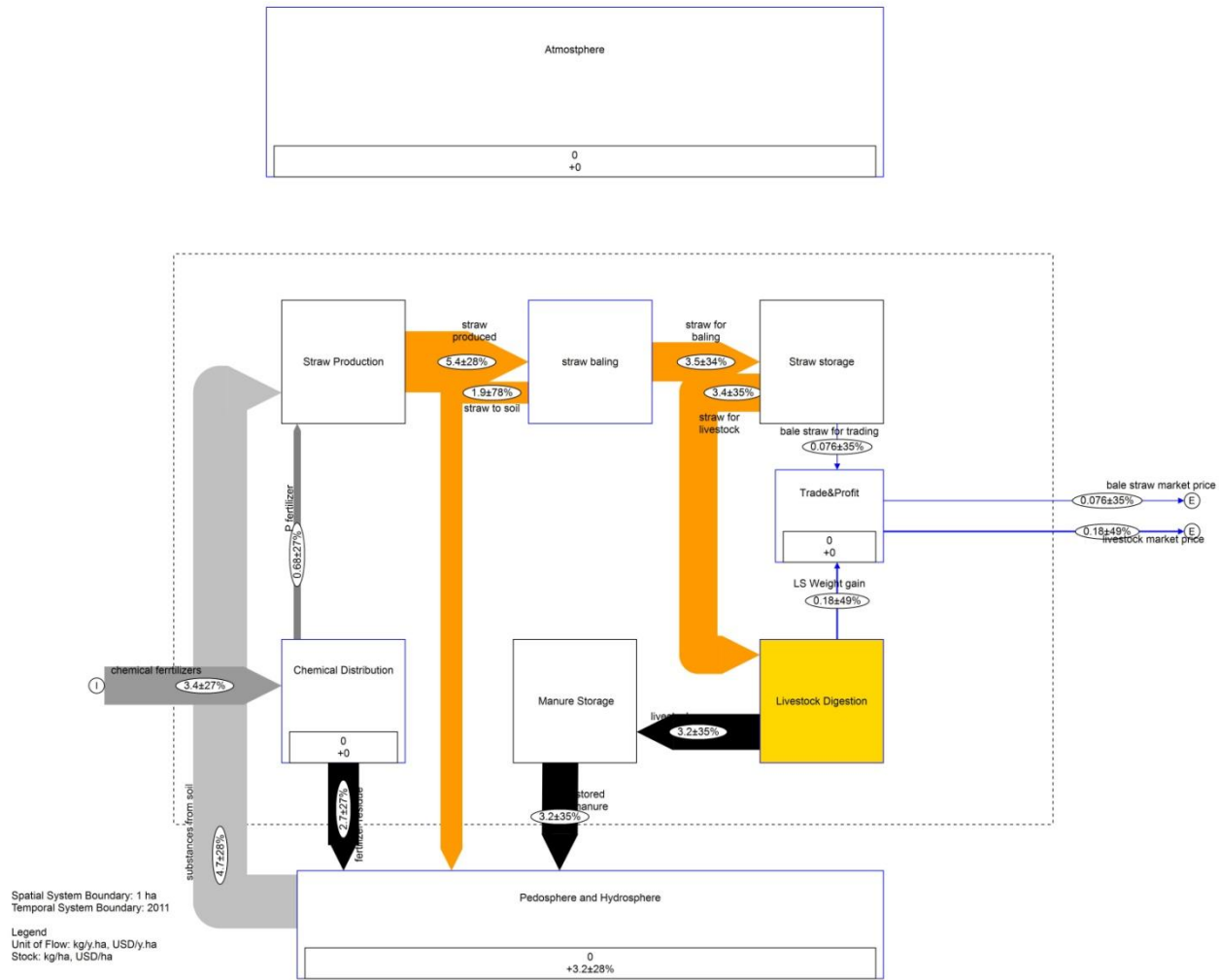

Fig. 4.14. Phosphorus flows (layer P) per ha in Scenario B "Fodder" on an exemplary farm in 2011

From SFA of scenario fodder, the distribution of C, N, and P from total input are explained as follows:

6.4% of total C input from CO<sub>2</sub> and urea are distributed to straw and RSM products. 52% of total C accumulate in soil from decomposition of typical waste and residues in 1 year (the same as those in Status Quo). 5.1% accumulate in the hydrosphere. 36% are emitted to the atmosphere as CO<sub>2</sub> and CH<sub>4</sub>.

35% of total N input from fertilizers, N from plants added for normal feedstock as in Status Quo, as well as N from soil are distributed in the scenario's products. 23% are emitted to atmosphere via N volatilization from denitrification of waste and residues released to soil as well as volatile N lost from U-lime treatment. 1.0% of the volatilized N remains as N<sub>2</sub>O in the atmosphere while most of it is deposited back to undefined locations of the pedosphere and hydrosphere. The yearly accumulations of N in farm soil and hydrosphere in this condition of land use are 5.8% and 16% of total N input, respectively. The remaining are recycled as plant nutrients from soil after the decomposition of waste and residues in soil.

3.2% and 31% of total P input from fertilizers and soil are distributed to the scenario's products and soil, respectively. 8.5% are lost into the hydrosphere. The remaining are recycled as plant nutrients from soil after the RSM waste and residues are decomposed.

#### 4.1.2.2. Scenario C “Energy”

In Scenario Energy (Fig. 4.15.- 4.18), not only the products mentioned in Scenario Fodder, but also 190 kg of biogas are produced. The waste and residue types are the slurry from the biogas digester as well as residues from left over straw and from fertilizers. Farmer’s profit is 580 USD/a from both direct income from trading of RSM products as well as indirect economic benefits to consume the self-produced biogas as HH energy instead of purchasing LPG for the same calorific value. This scenario emits 130 kg CH<sub>4</sub> from livestock production as well as 1300 kg CO<sub>2</sub> and 0.0.15 kg N<sub>2</sub>O.

The relevant data of pollutant emissions and substances accumulation are concluded in Table 4.4.

Table 4.4. Material and substance dynamics per ha from RSM in Scenario C "Energy" of an exemplary farm in 2011

Indicators		Value	Unit
Total substances input for straw utilization	C	1300	kg/y.ha.
	N	54	kg/y.ha
	P	8.1	kg/y.ha
GHG emission		4100	kg CO <sub>2</sub> e/y.ha
CO emission		0	kg/y.ha.
PM emission		0	kg/y.ha.
Substances primarily exported to atmosphere	C	470	kg/y.ha.
	N	9.6	kg/y.ha.
	P	0	kg/y.ha.
Substances exported then accumulate in hydrosphere	C	63	kg/y.ha
	N	7.4	kg/y.ha
	P	0.69	kg/y.ha
Substances exported then accumulate in farm soil	C	590	kg/y.ha
	N	3.2	kg/y.ha
	P	2.5	kg/y.ha
Substances exported in farm products	C	180	kg/y.ha
	N	21	kg/y.ha
	P	0.26	kg/y.ha
Economic profit		580	USD/y.ha

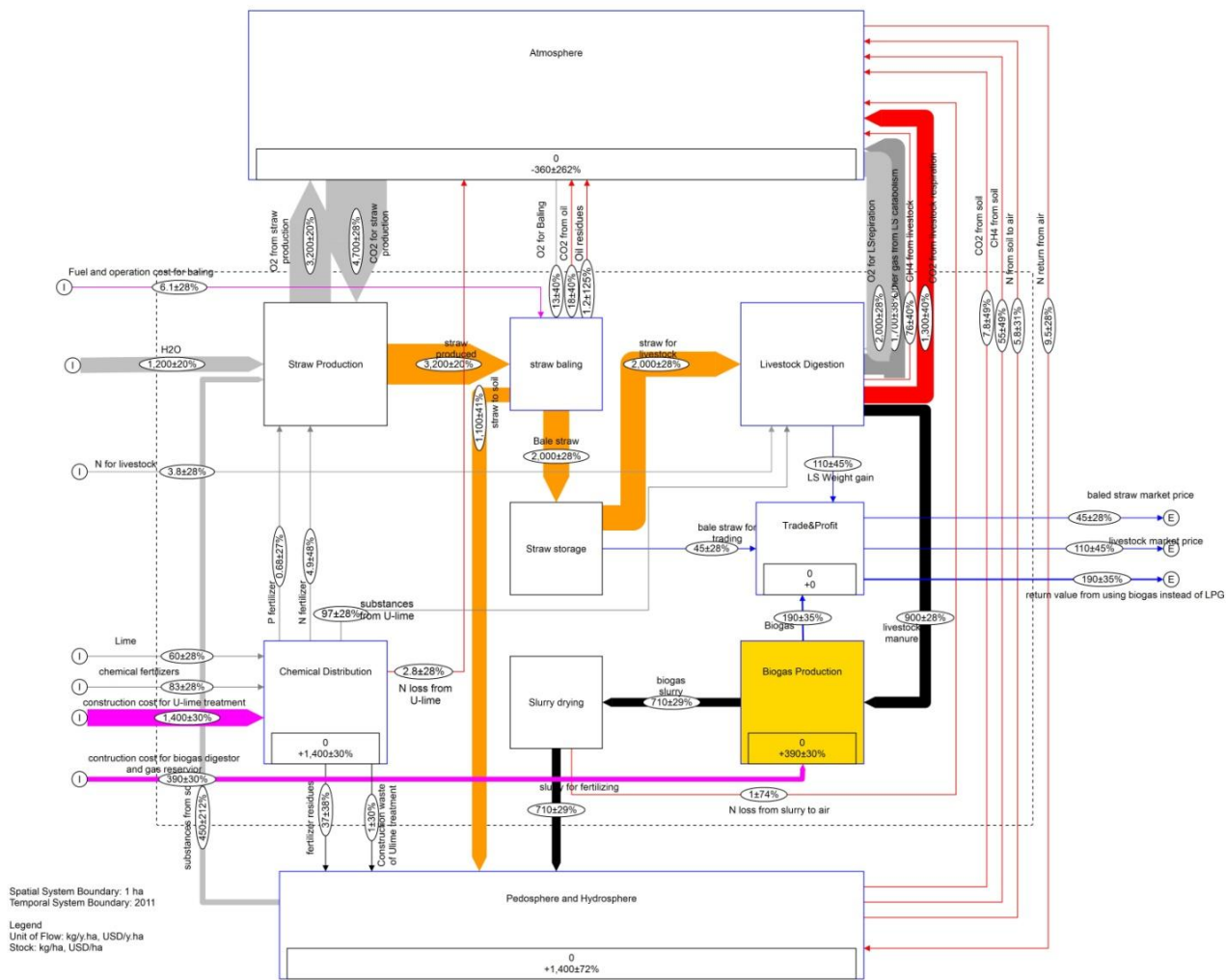

Fig. 4.15. Material flows (layer Goods) per ha in Scenario C "Energy" on an exemplary farm in 2011

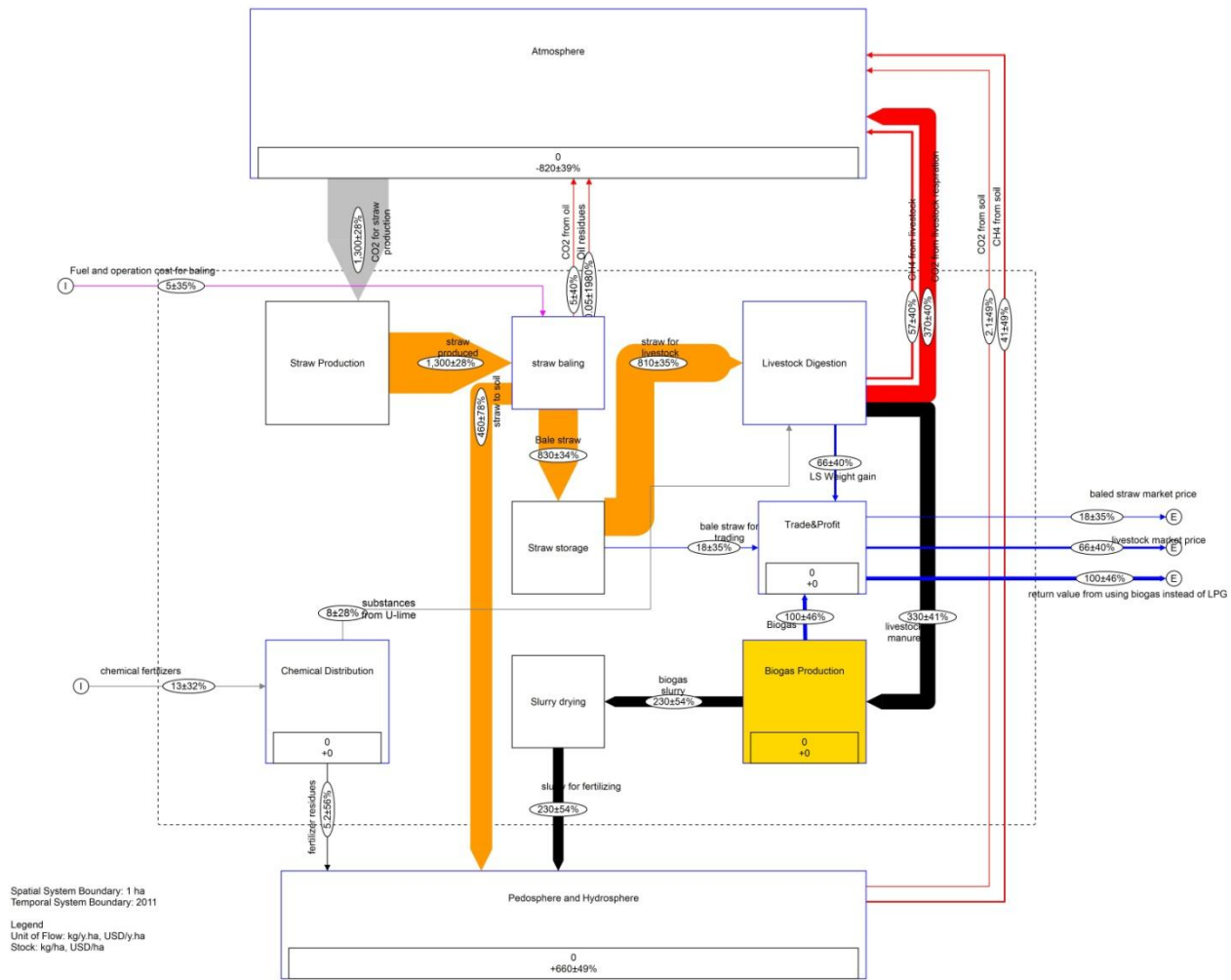

Fig. 4.16. Carbon flows (layer C) per ha in Scenario C "Energy" of an exemplary farm in 2011

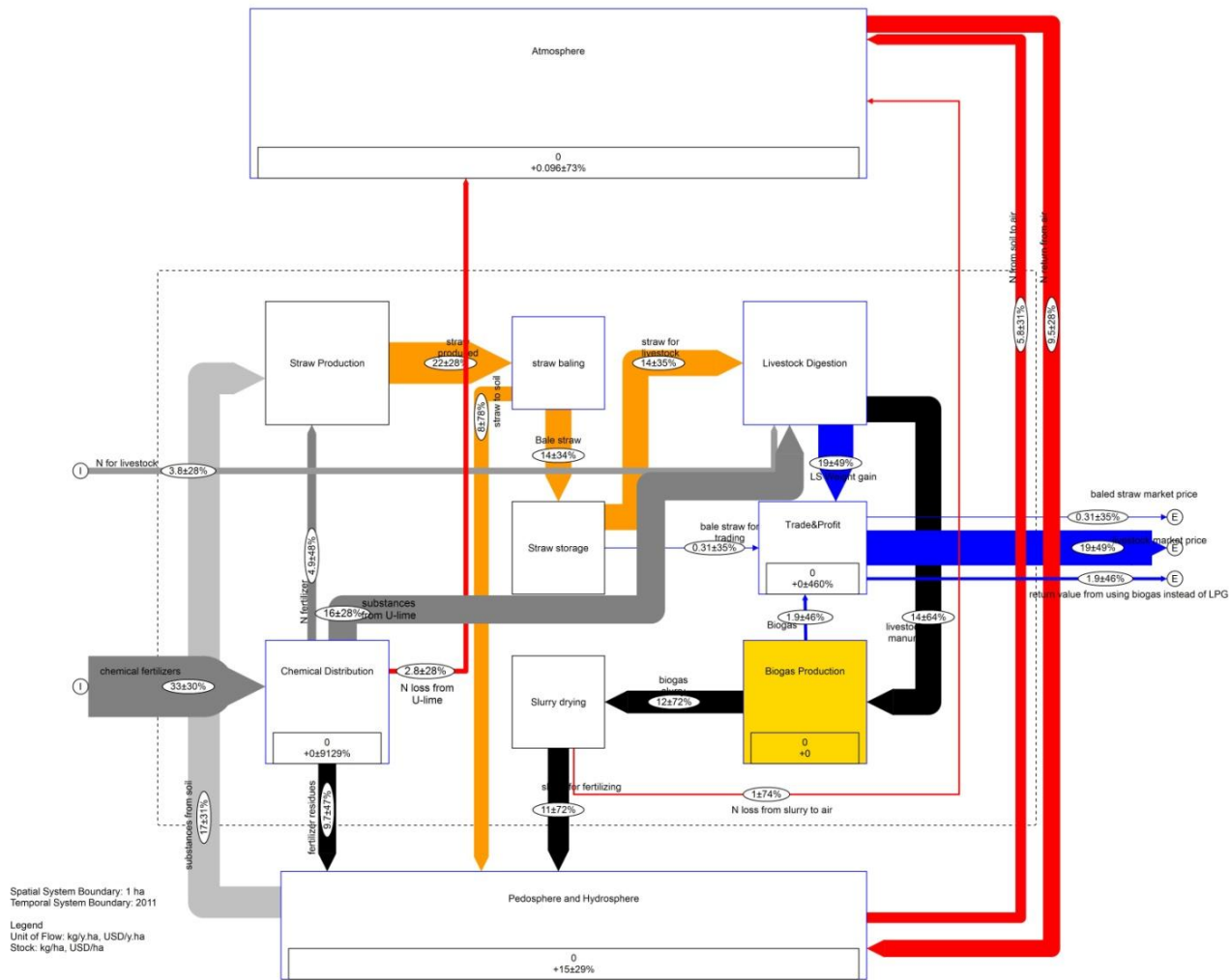

Fig. 4.17. Nitrogen flows (layer N) per ha in Scenario C "Energy" on an exemplary farm in 2011

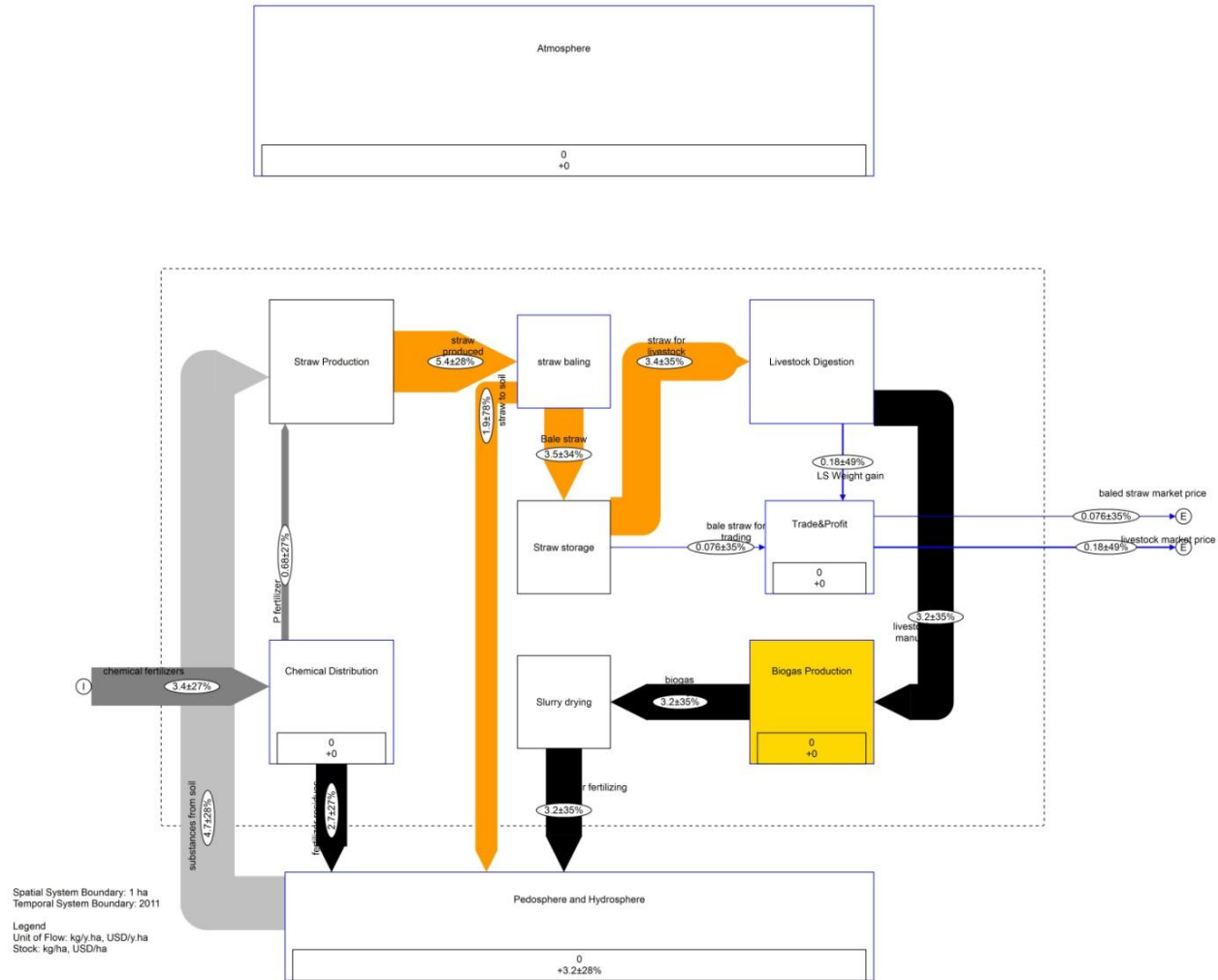

Fig. 4.18. Phosphorus flows (layer P) per ha in Scenario C "Energy" on an exemplary farm 2011



From SFA of scenario energy, the distributions of substance C, N, P are explained as follows:

14% of total C consumed from the same sources as in scenario fodder are used for producing the scenario's products. 45% accumulate into soil from left-over straw, digester slurry, and a tiny amount from fertilizers. 4.8% accumulate in the hydrosphere. The remaining are emitted to the atmosphere as CO<sub>2</sub> and CH<sub>4</sub>.

39% of total N input from the same sources as in scenario fodder are accumulated in the scenario's products. 18% of the total input are lost to the atmosphere via N volatilization from digester slurry and soil denitrification as well as from U-lime treatment of straw for feeding livestock. 1.0% of total volatile N is transformed into N<sub>2</sub>O in the atmosphere while most of it is deposited back to an undefined location of the pedosphere and hydrosphere. The accumulation of N in soil and hydrosphere each year is 5.9% and 14% of the total N input. The remaining is recycled as plant nutrients from soil after the RSM waste and residue are decomposed in soil.

3.2% and 31% of total P consumed (8.1 kg) from the same sources as in scenario fodder are distributed to the scenario's products and soil, respectively. 8.5% of total P are accumulated into the hydrosphere as in Scenario Food and Fodder. The remaining are recycled as nutrients from soil.

#### 4.1.2.4. Scenario D “Construction”

In Scenario Construction (Fig. 4.19-4.22), all straw from RSOB is used as material for producing 110,000 kg or 23,000 blocks of straw brick. The waste and residue types for fertilizing the farm soil are the same as in Status Quo including a small amount of wastes from the brick production. Farmer’s profit is 520 USD/a. This scenario emits 62 kg CH<sub>4</sub> from livestock production as well as 340 kg CO<sub>2</sub> and 0.090 kg N<sub>2</sub>O.

The relevant data of pollutant emissions and substances accumulation are concluded in Table 4.4.

Table 4.4. Material and substance dynamics per ha from RSM in Scenario D "Construction of an exemplary farm in 2011

Indicators		Value	Unit
Total substances input for straw utilization	C	1300	kg/y.ha.
	N	41	kg/y.ha.
	P	9.9	kg/y.ha.
GHG emission		1700	kg CO <sub>2</sub> e/ha
CO emission		0	kg/y.ha.
PM emission		0	kg/y.ha.
Substances primarily exported to atmosphere	C	135	kg/y.ha.
	N	5.7	kg/y.ha.
	P	0	kg/y.ha.
Substances exported then accumulate in hydrosphere	C	49	kg/y.ha.
	N	5.0	kg/y.ha.
	P	0.63	kg/y.ha.
Substances exported then accumulate in farm soil	C	460	kg/y.ha.
	N	2.8	kg/y.ha.
	P	2.2	kg/y.ha.
Substances exported in farm products	C	640	kg/y.ha.
	N	16	kg/y.ha.
	P	2.7	kg/y.ha.
Economic profit		520	USD/y.ha.

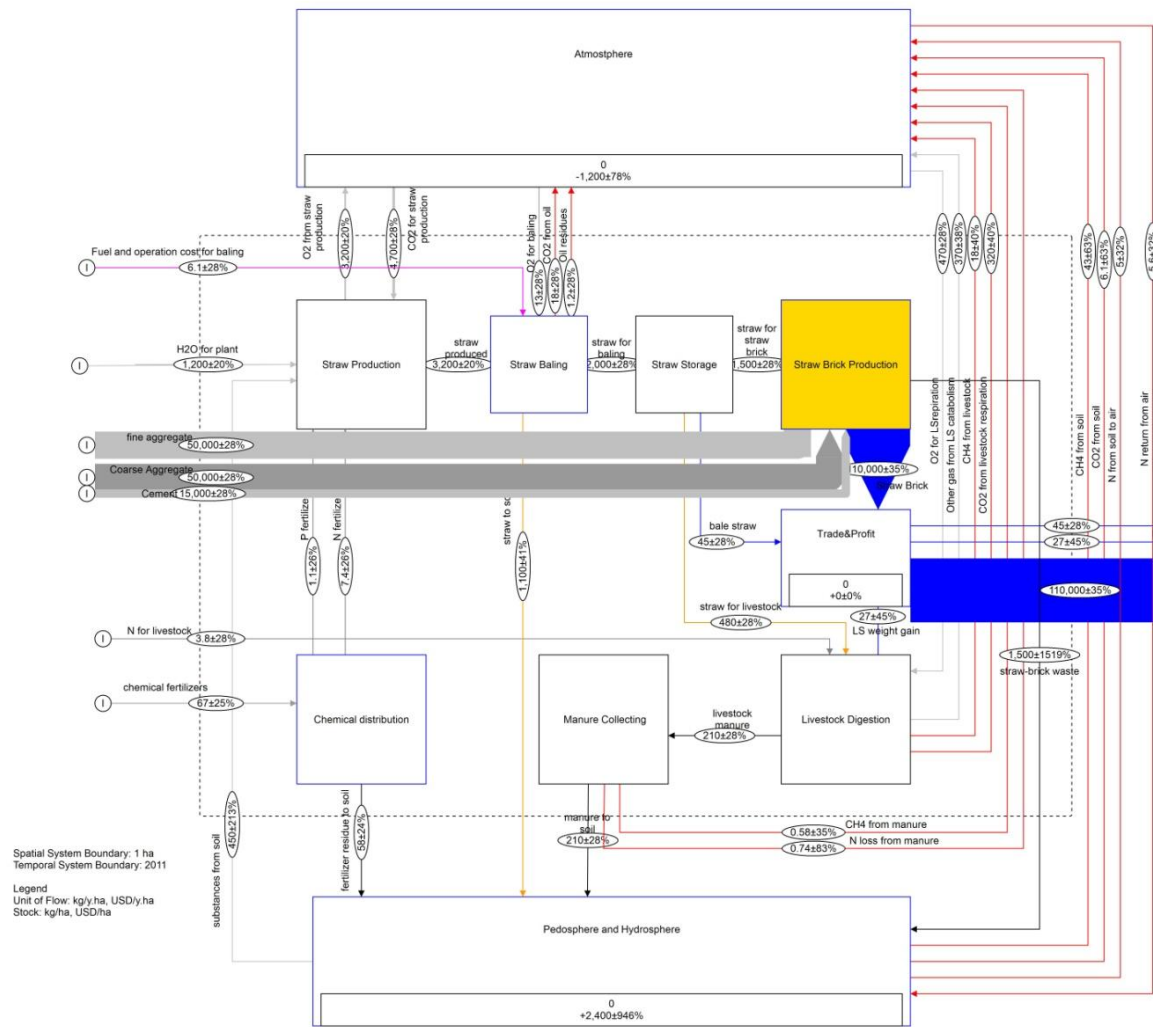

Fig. 4.19. Material flows (layer Goods) per ha in Scenario D "Construction" on an exemplary farm in 2011

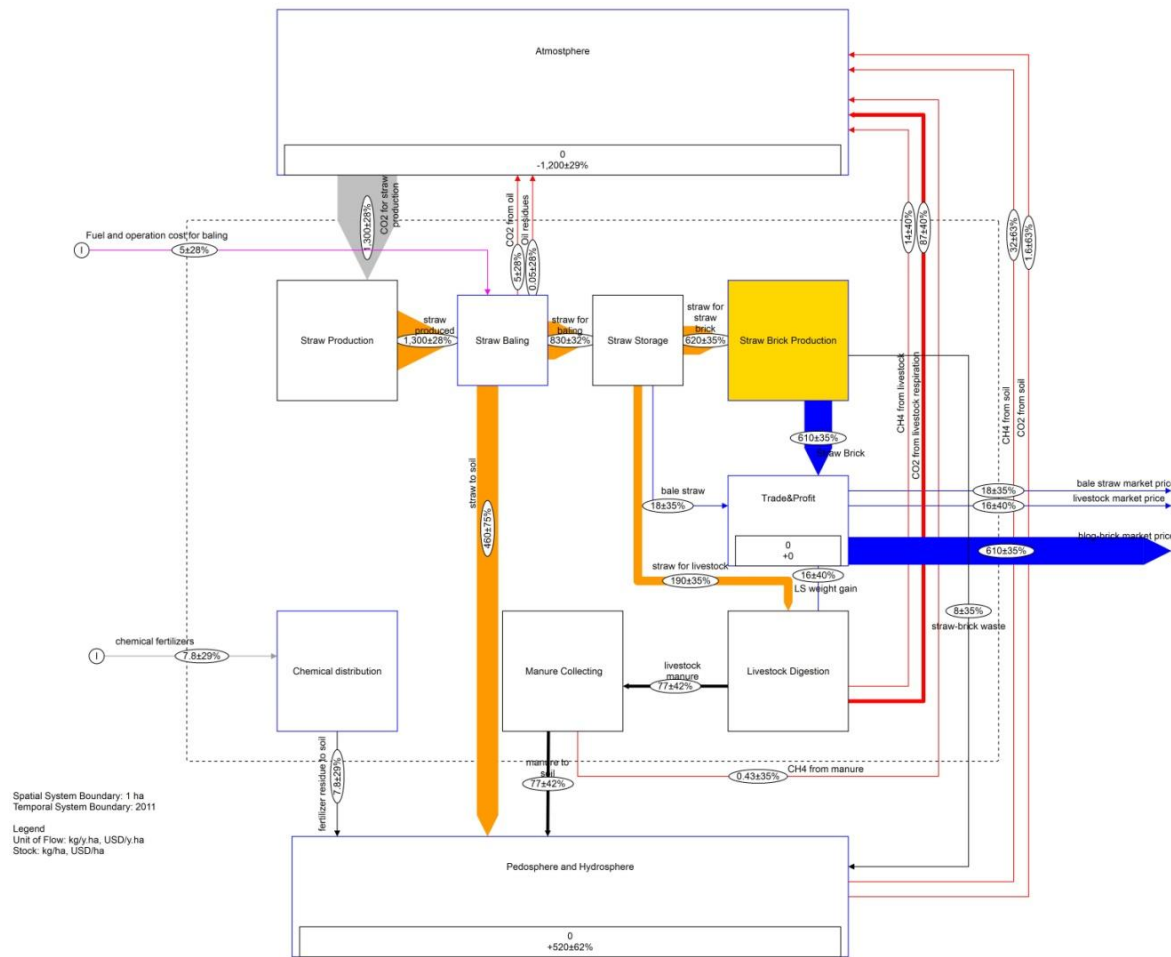

Fig. 4.20. Carbon flows (layer C) per ha in Scenario D "Construction" on an exemplary farm in 2011

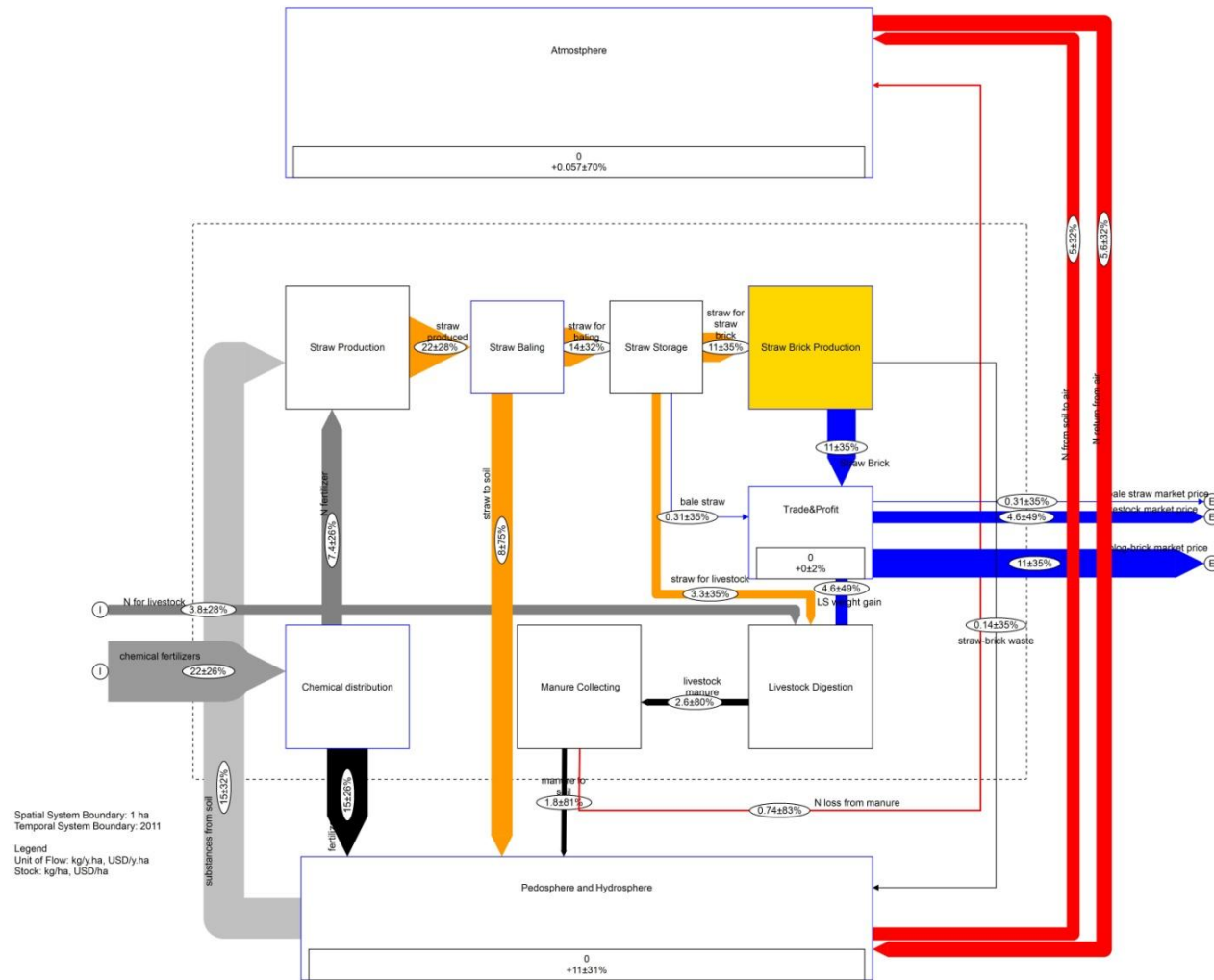

Fig. 4.21. Nitrogen flows in (layer N) per ha Scenario D "Construction" on an exemplary farm in 2011

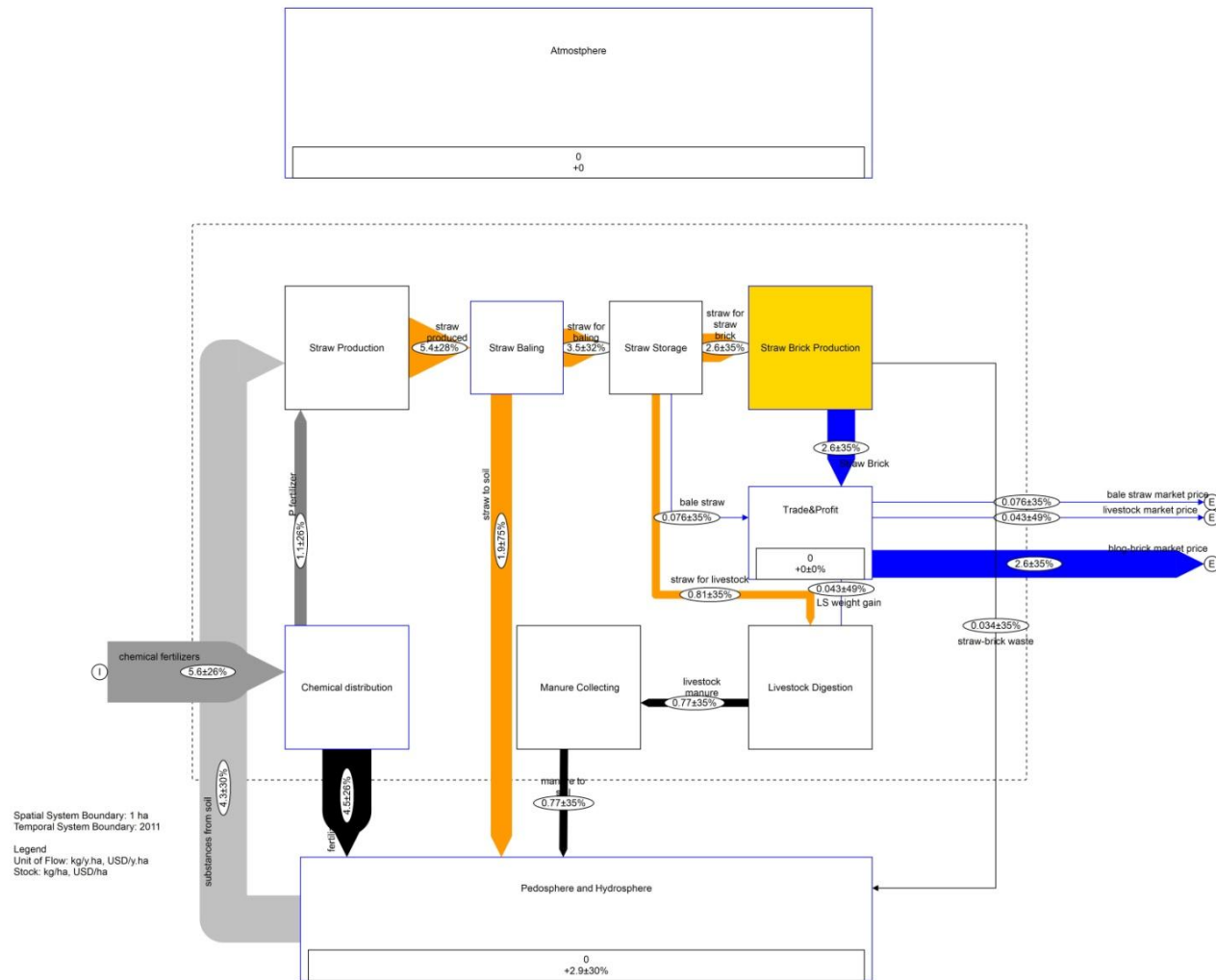

Fig. 4.22. Phosphorus flows (layer P) per ha in Scenario D "Construction" on an exemplary farm in 2011

From SFA of scenario construction, the distributions of substance C, N, P are explained as follows:

49% of total C input, same as in Status Quo, for producing straw and RSM products are distributed to this scenario's products, while 35% accumulate in soil from residue decomposition. 3.7% accumulate in the hydrosphere. 10% are emitted to the atmosphere as CO<sub>2</sub> and CH<sub>4</sub>.

39% of total N input, in this scenario, same as that in Status Quo, are used for producing the scenario's products. 14% are lost to atmosphere via N volatilization from manure and soil denitrification, but subsequently, 99% are deposited back to the undefined pedosphere and hydrosphere. The accumulation of N in soil and hydrosphere are 6.9% and 12% of total N input. The remaining is recycled as soil nutrient.

27% of total P input in this scenario are distributed to the scenario's products as in Status Quo. 22% of the total amount of P accumulate in soil while 6.4% is lost from the scenario's waste and residues accumulated into the hydrosphere. The remaining are recycled as nutrients from soil after the waste and residues have decomposed in the soil.

The comparison of GHG emissions in all scenarios are shown in Fig.4.23. Scenarios food and construction emit less GHG to the atmosphere than scenarios Fodder and Energy, and Status Quo. For all scenarios, CO and PM emissions are completely eliminated (as mentioned in previous paragraphs).

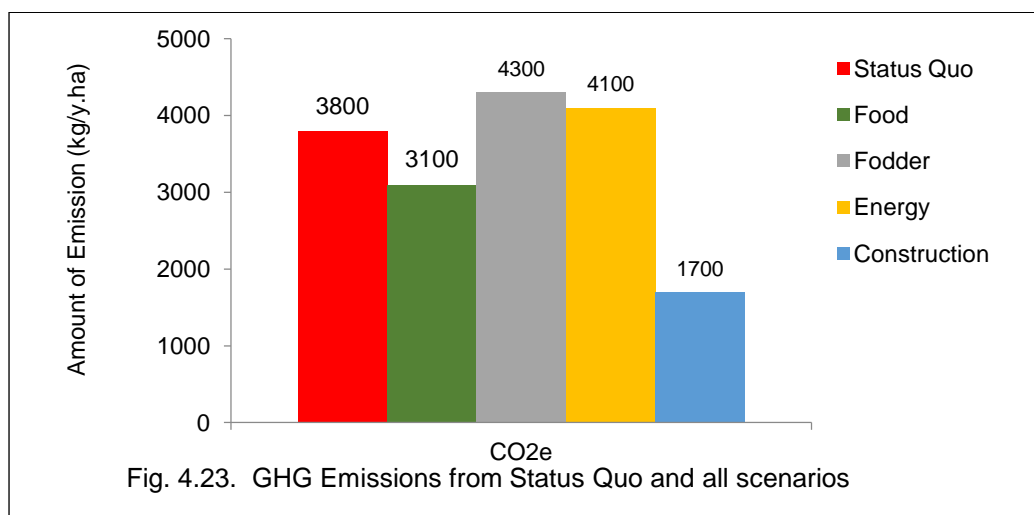

The comparison of substances distributed into different sinks, e.g. atmosphere, hydrosphere, farm soils, as well as RSM products, are shown in the graphs 4.24-4.26 as percentages of substances distributed from the total substances for straw utilization and producing RSM products in the system.

In all scenarios, 140-480 kg/y.ha C and 5.7-13 kg/y.ha N are primarily emitted to the atmosphere, less than those in status Quo (710 kg/y.ha C and 15 kg/y.ha N). Furthermore, in all scenarios, P is no longer emitted to the atmosphere (Fig. 4.24).

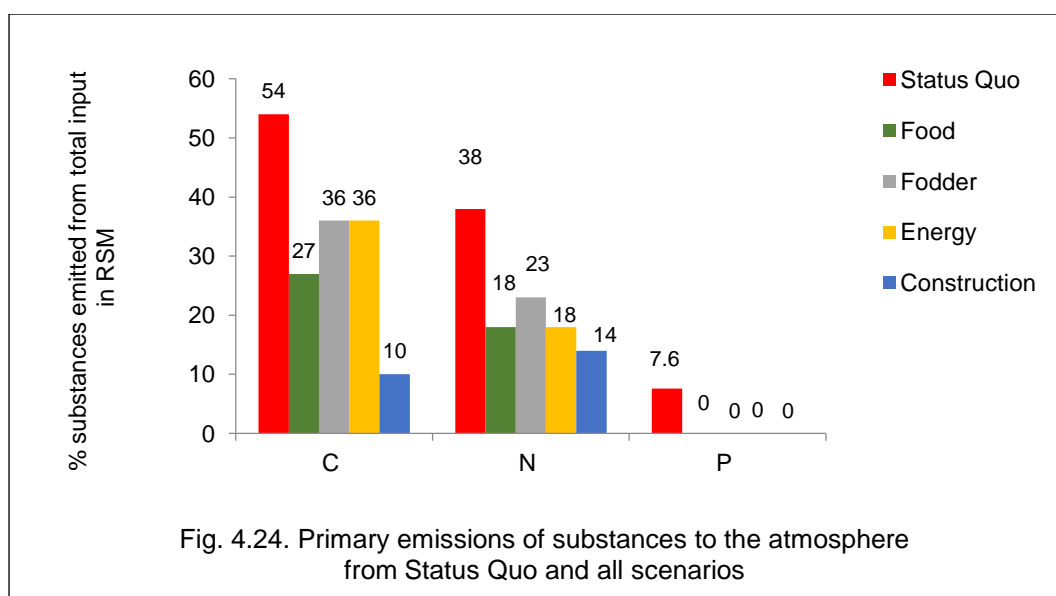



In the hydrosphere (Fig. 4.25), the accumulation of 63-87 kg/y.ha of C from Scenario Food, Fodder, and Energy are higher than in Status Quo (56 kg/y.ha). Otherwise, all substances from Scenario construction as well as N and P for every improved scenario are less than in Status Quo (9.9 kg/y.ha N, and 1 kg/y.ha P).

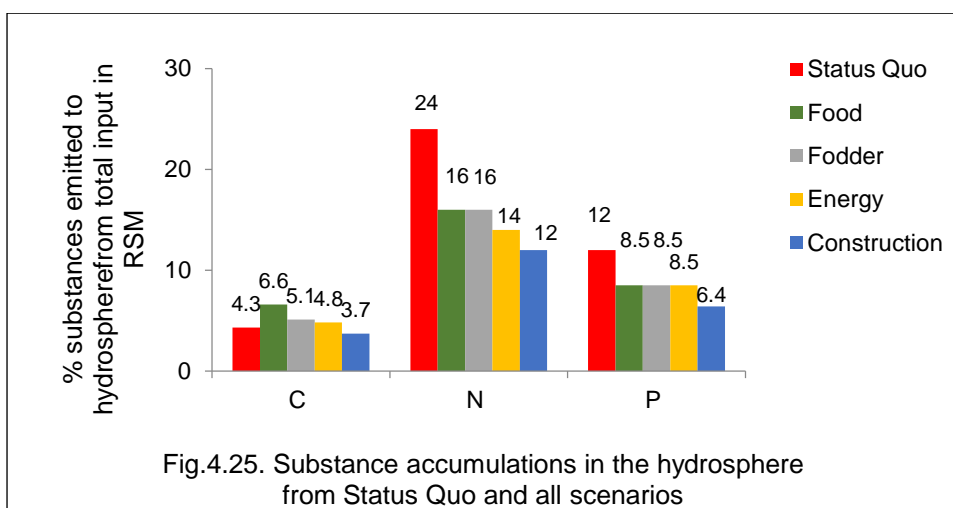

All scenarios except scenario construction release a higher amount of C (590-820 kg/y.ha) and P (2.5 kg/y.ha) to accumulate in soil than those from Status Quo (510 kg/y.ha C and 2.4 kg/y.ha P). Only scenario Construction distributes less C and P to soil than in Status Quo. Although scenario fodder and energy provide higher N to soil (3.2 kg/y.ha N) than in Status Quo (2.8 kg/y.ha), the percentages of N release from their total input to RSM to soil are lower, as shown in Fig. 4.26.

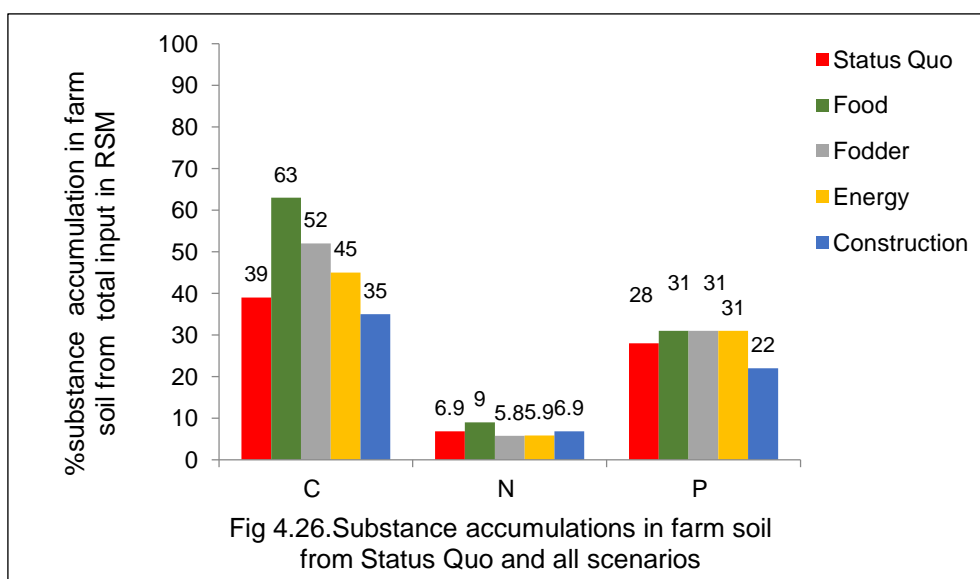

To compare resource efficiencies in terms of the percentage of substances distributed into useful products, RSM products from total input are compared (Fig. 4.27). All scenarios distribute and utilize C, N, P higher than in Status Quo. Scenario construction provides the highest C and P efficiencies to its products while scenario energy and scenario construction provide the highest N efficiency to its products.

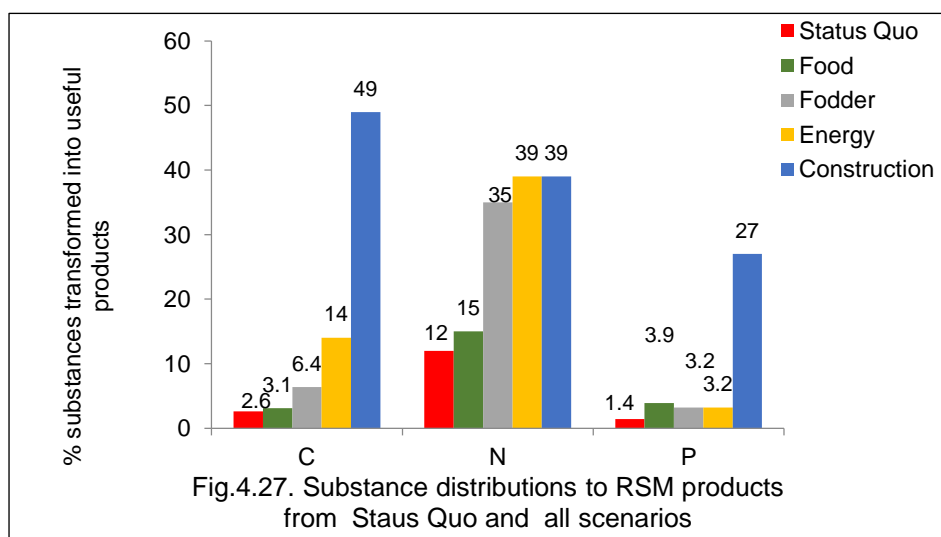

To compare the maximum money reserves that farmers need to prepare for labour, operation, and material costs, including the construction costs for the treatment unit in the first year. Scenarios fodder and energy need construction units for U-lime treatment and biogas digester to be built while Status Quo, scenario food, and scenario construction don't need any extra construction units.

The total investment costs of each scenario for first year operation are shown in Fig. 4.28.

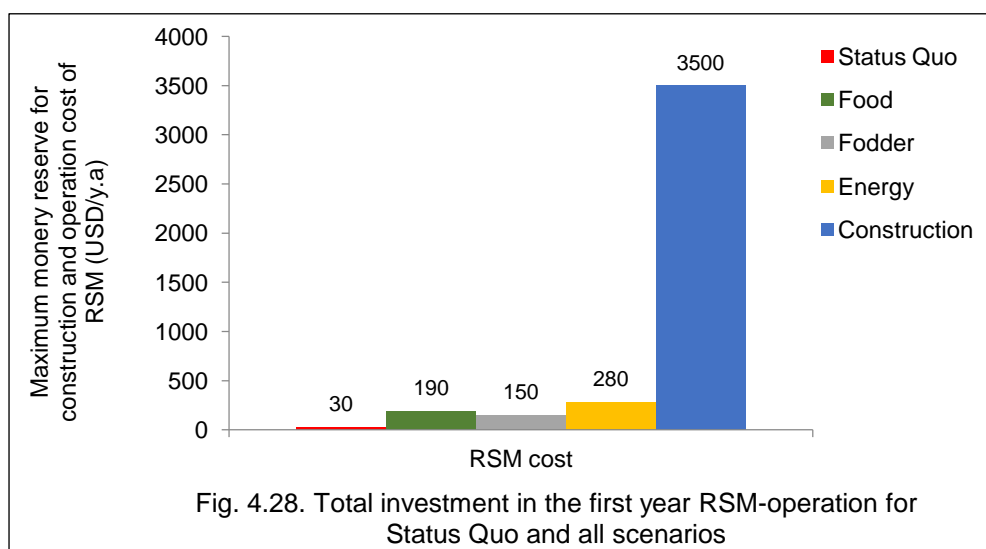
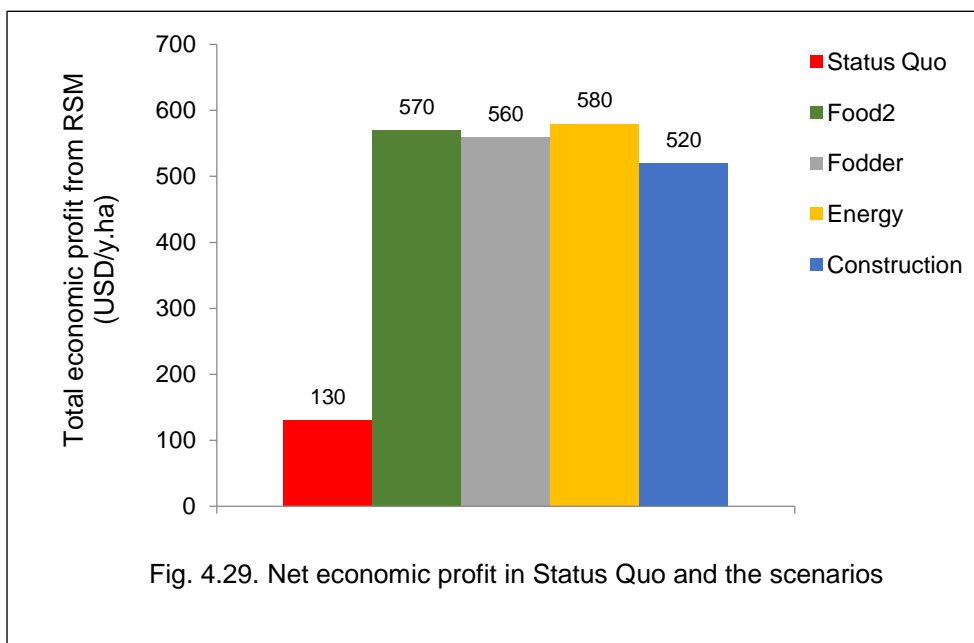

Fig. 4.28 shows that All scenarios need to meet investment costs compared to Status Quo (30 USD/y.ha). Scenario Construction needs the highest investment (3500 USD/y.ha), same for first year and every year for only operation cost of e.g. materials, labour. Without construction costs, the money needed for material and labour costs is 190 USD/y.ha for scenario food, 100 USD/y.ha for scenario fodder and energy, i.e. much lower than in scenario construction (3500 USD/y.ha)

In view of economic profit (Fig. 4.29), all scenarios result in much higher net income (520-580 USD/y.ha) than in Status Quo. The highest income is from Scenario Energy, followed by Scenario Food, Fodder, and Construction, respectively.



#### 4.1.3. Actual results from the optimized scenario

The optimized scenario combines the results from Status Quo and all scenarios in order to reduce environmental problems, increase resource efficiency as well as increasing economic profit to motivate the farmers. The imported materials are the same as in Status Quo with the addition of material for mushroom cultivation, lime for improving livestock feed, duckweed inoculum, as well as tilapia fingerling. One additional product to Status Quo and all scenarios is 8.2 kg DW Tilapia (27 kg FW). Total products of the optimized scenario are given in table 4.5.

Table 4.5. RSM products from optimized scenario

RSM products	Amounts (kg DW/y.ha)
Bale straw	45
Mushroom	17
Livestock weight gain	54
Biogas	90
Tilapia	8.2
Straw brick	95

This scenario emits 3000 kg/y.ha GHG containing 900 kg CO<sub>2</sub>, 100 kg CH<sub>4</sub>, and 0.12 kg N<sub>2</sub>O. CO and PM are not generated from straw utilization. Farmer's profit is 610 USD/y.ha of direct income from trading products and indirect income by using their own products instead of buying them from the market.

The relevant data of pollutant emissions and substance's accumulation are concluded in Table 4.6. MFA, SFA, and EA of Optimized scenario are shown in Fig. 4.30-4.34.

Table 4.6. Material and substance dynamics per ha from RSM in the optimized scenario of an exemplary farm in 2011

Indicators		Value	Unit
Total substances input to RSM system	C	1300	kg/y.ha.
	N	45	kg/y.ha
	P	8.2	kg/y.ha
GHG emission		3000	kg CO <sub>2</sub> e/y.ha
CO emission		0	kg/y.ha.
PM emission		0	kg/y.ha.
Substances primarily exported to atmosphere	C	400	kg/y.ha.
	N	7.8	kg/y.ha.
	P	0	kg/y.ha.
Substances exported then accumulate in hydrosphere	C	78	kg/y.ha
	N	6.7	kg/y.ha
	P	0.69	kg/y.ha
Substances exported then accumulate in farm soil	C	740	kg/y.ha
	N	3.5	kg/y.ha
	P	2.5	kg/y.ha
Substances exported in farm products	C	110	kg/y.ha
	N	12	kg/y.ha
	P	0.32	kg/y.ha
Economic profit		610	USD/y.ha

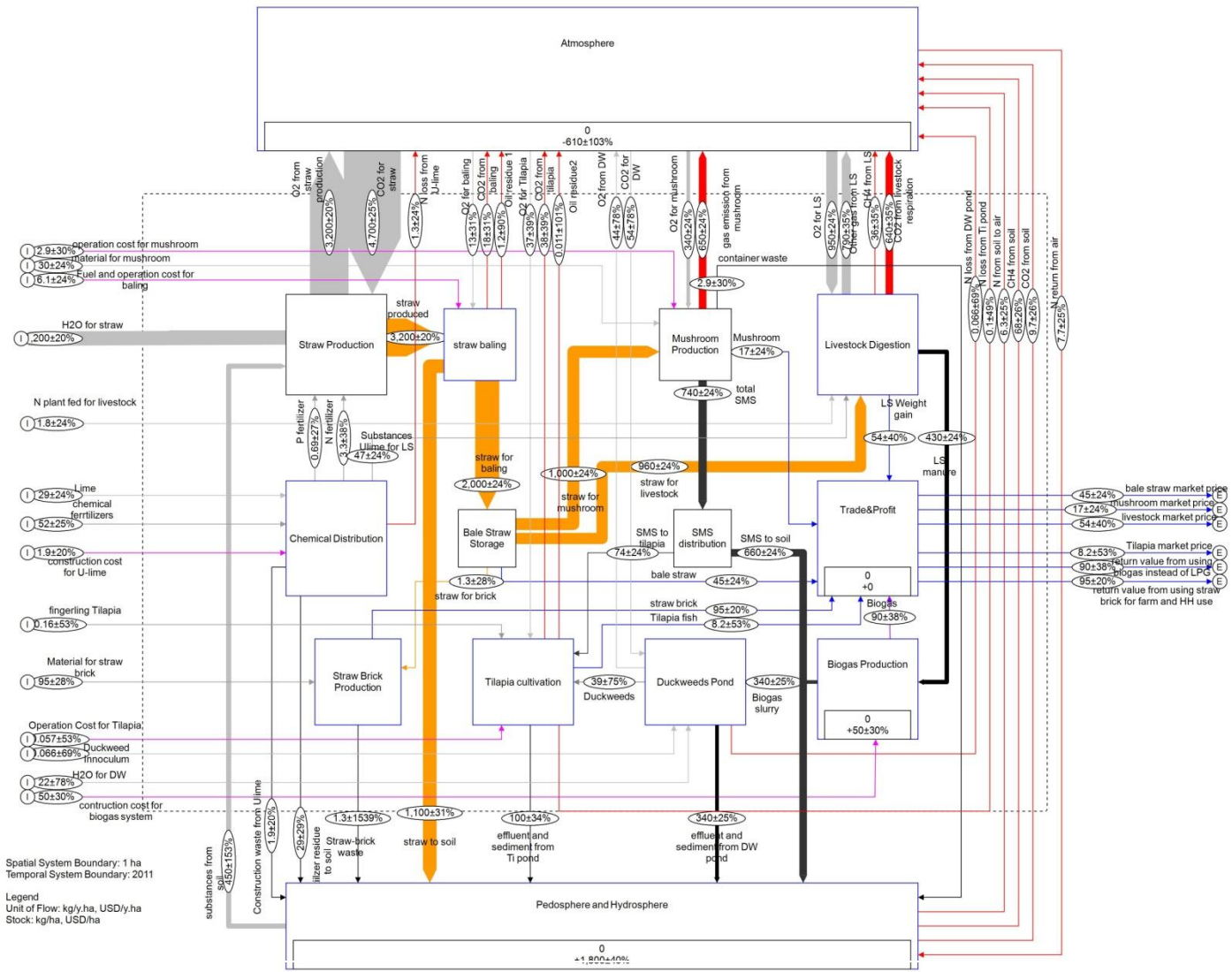

Fig. 4.30. Material flows (Layer Goods) per ha in the optimized scenario on an exemplary farm in 2011

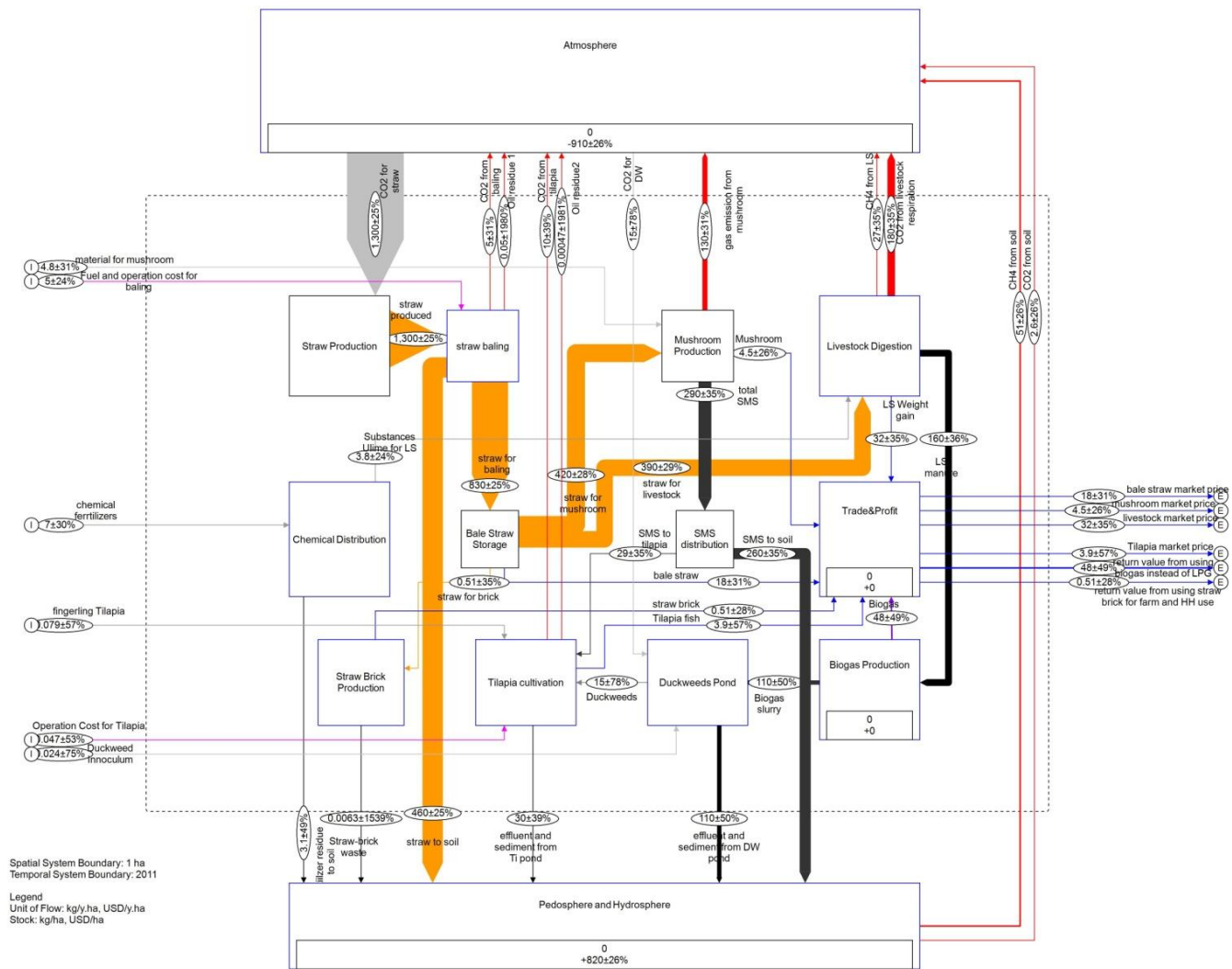

Fig. 4.31. Carbon flows (Layer C) per ha in the optimized scenario on an exemplary farm in 2011

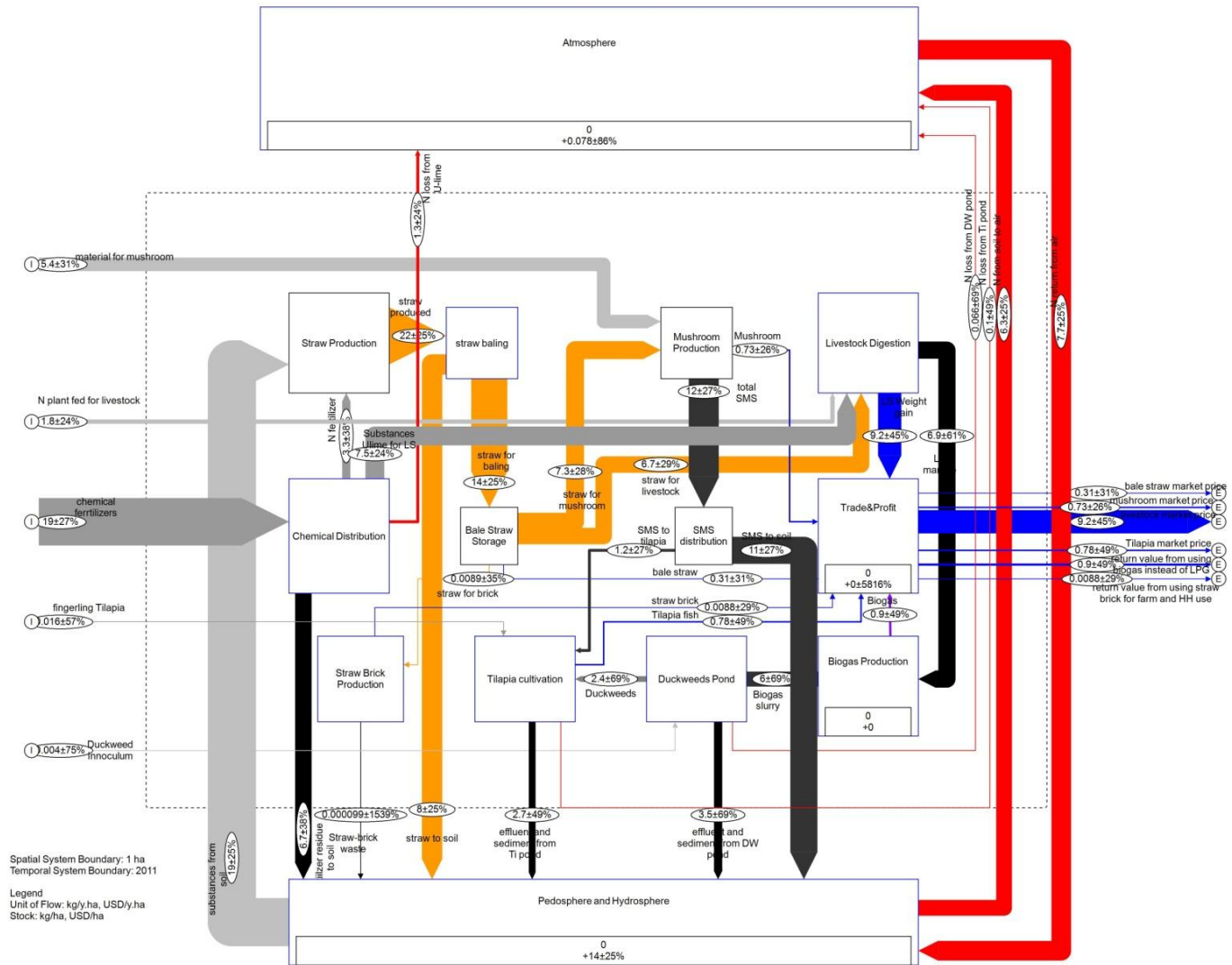

Fig. 4.32. Nitrogen flows (Layer N) per ha in the optimized scenario on an exemplary farm in 2011



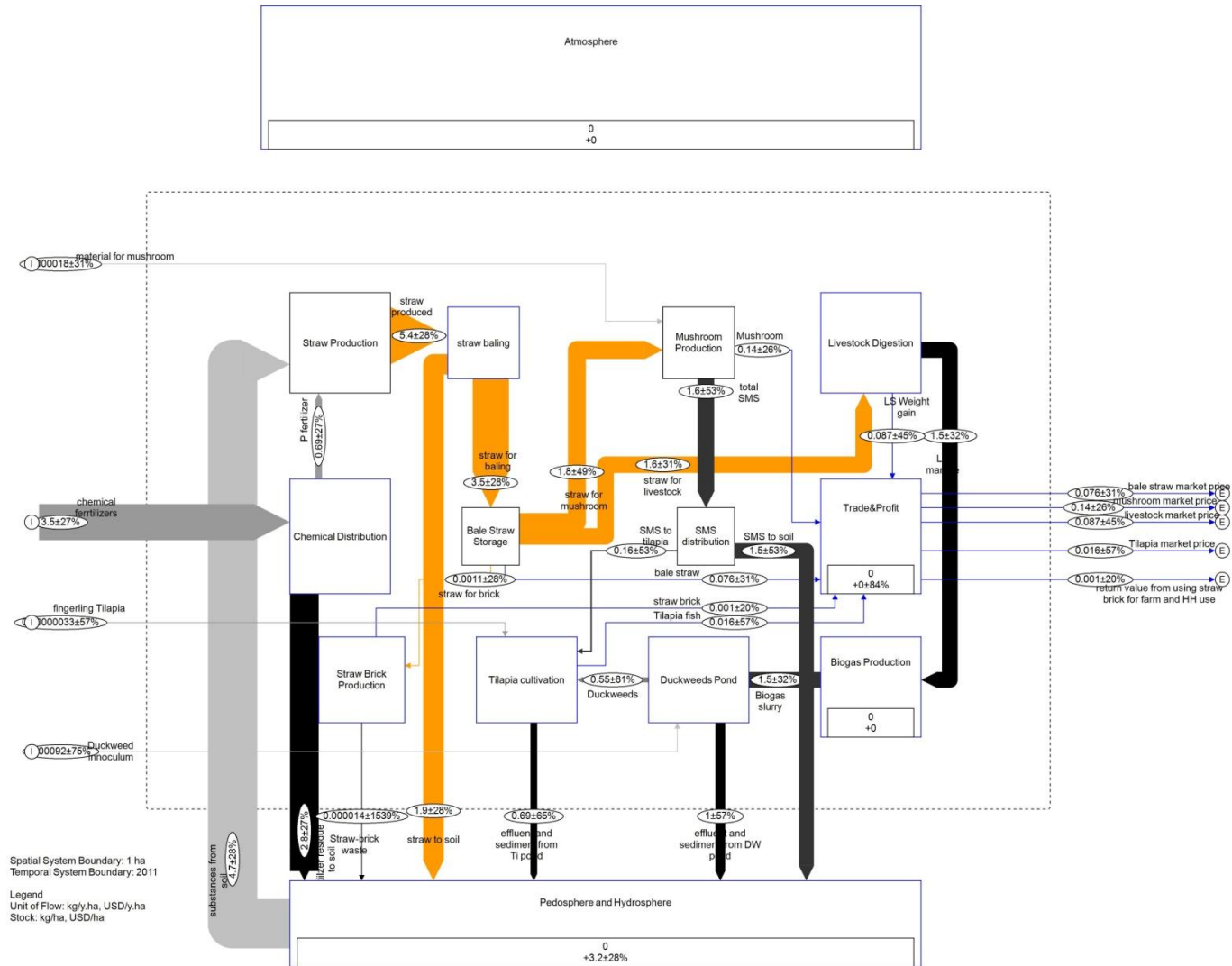

Fig. 4.33. Phosphorus flows (Layer P) per ha in the optimized scenario on an exemplary farm in 2011

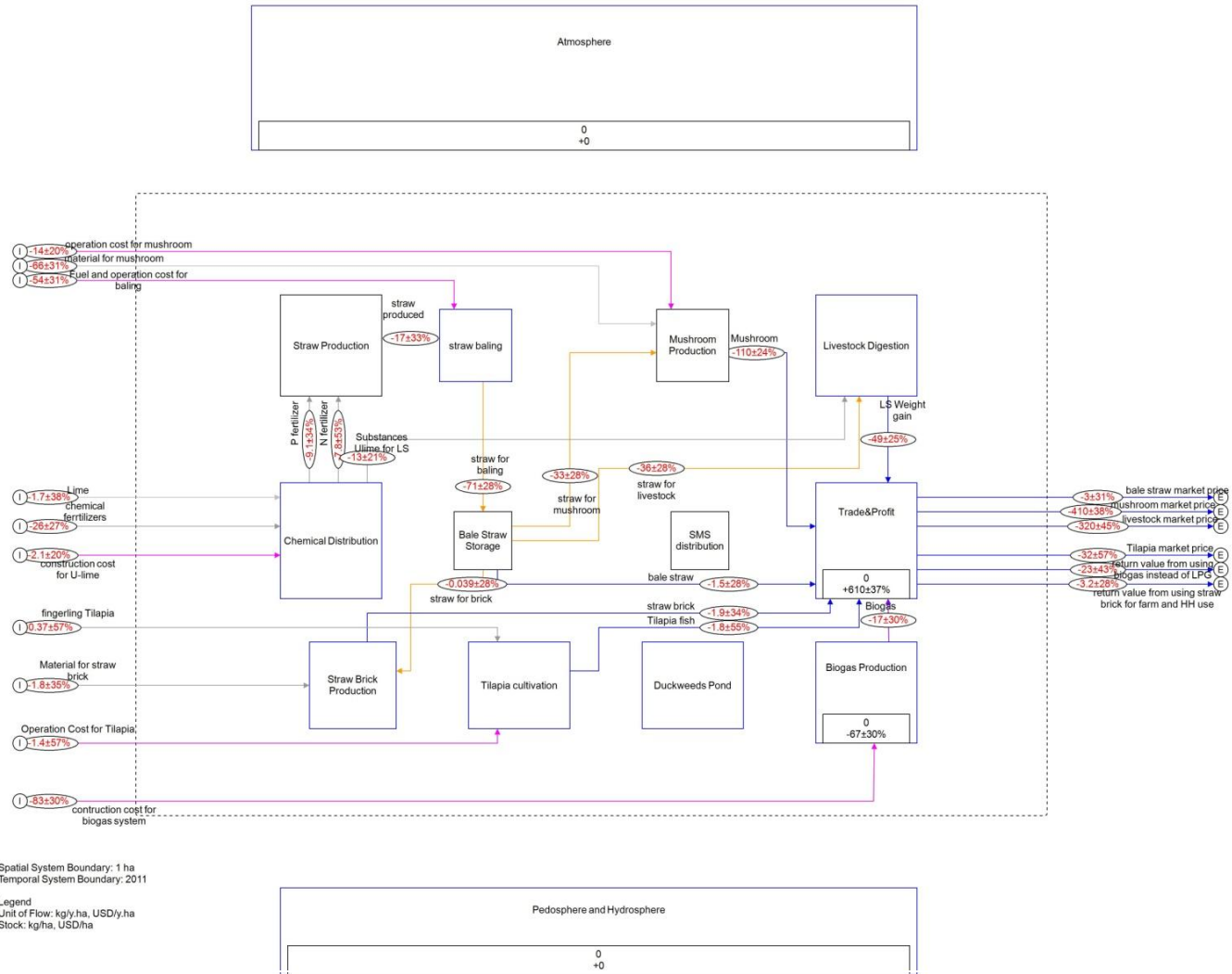

Fig. 4.34. Cost and profit flows (Layer Money) per ha in optimized scenario on an exemplary farm in 2011

In view of substances distributed from total import into RSM, the percentages of C, N, P distributions are described as follows.

8.1% of total C input for straw production and all material utilizing straw and its residues are used for producing the scenario's products while 30% are emitted to the atmosphere as CO<sub>2</sub> and CH<sub>4</sub>. 56% accumulate into soil from residue decomposition. The remaining accumulate in the hydrosphere.

26% of total N input from all material for producing and utilizing straw and its residues as well as from soil, accumulate in the scenario's products. 17% are lost to atmosphere via N volatilization from soil denitrification and from U-lime treatment. 1% of this volatile N remains in the atmosphere as N<sub>2</sub>O while most of them are deposited back to an undefined location of the pedosphere and hydrosphere. 7.7% and 15% from total N input accumulate in the soil and hydrosphere, respectively. The remaining are recycled as plant nutrients from soil.

3.9% of total P input into the system from all materials producing and utilizing straw and its residues as well as from soil are distributed into scenario's products. 30% and 8.4% of total P are accumulated in soil and hydrosphere, respectively. The remaining are recycled as plant nutrients from soil.

In term of pollutants emissions, the relevant indicators are air pollutants emitted in Status Quo e.g. GHG, CO, and PM. The GHG emissions in the Optimized scenario are reduced by 800 kgCO<sub>2</sub>e to 3000 kgCO<sub>2</sub>e while CO and PM are completely eliminated from the optimized RSM, as shown in Fig.4.35.

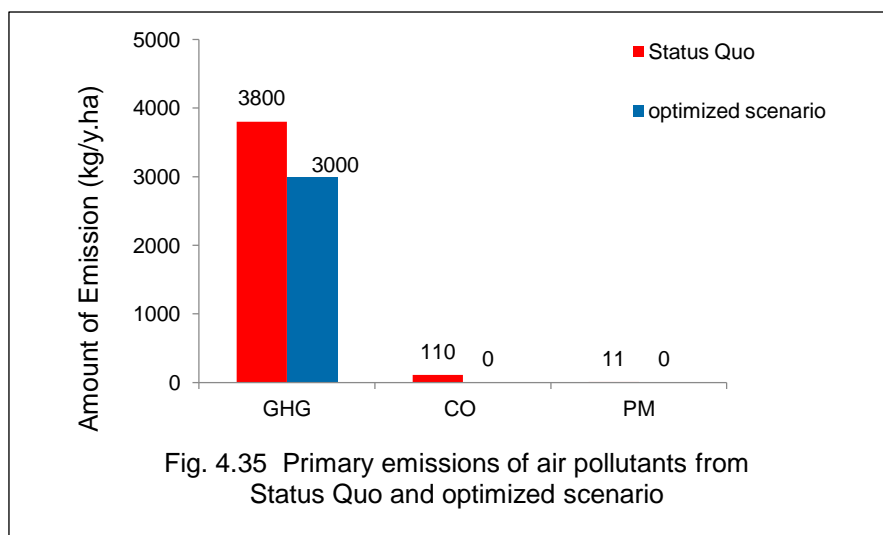

The comparison of substance distribution into different sinks e.g. atmosphere, hydrosphere, farm soils, as well as RSM products are shown in the graphs as percentages of substances distributed from total substances entering into the RSM system.

Compared with Status Quo, C and N emissions to the atmosphere from the optimized scenario are reduced from 710 kg C/y.ha and 15 kg N/y.ha to only 400 kg C/y.ha C and 7.8 kg N/y.ha while completely eliminating P emissions. The percentages of substance emissions are shown in Fig. 4.36.

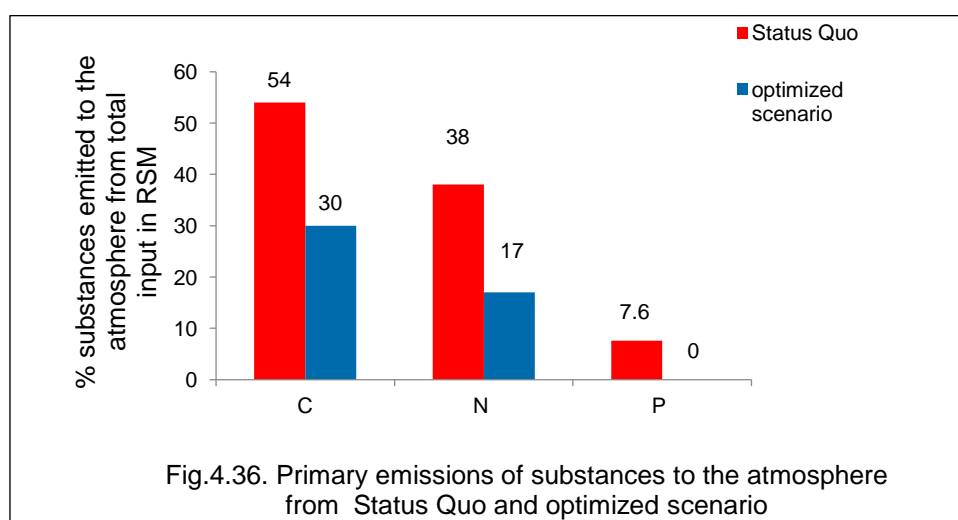

Although the accumulation of 78 kg/y.ha C in the hydrosphere from the optimized scenario is higher than 56 kg/y.ha from Status Quo, the accumulations of N and P in this scenario (6.7 kg/y.ha N and 0.69 kg/y.ha P) are less than in Status Quo (9.9 kg/y.ha N and 1.0 kg/y.ha P). The percentages of substance accumulation in hydrosphere are shown in Fig. 4.37.

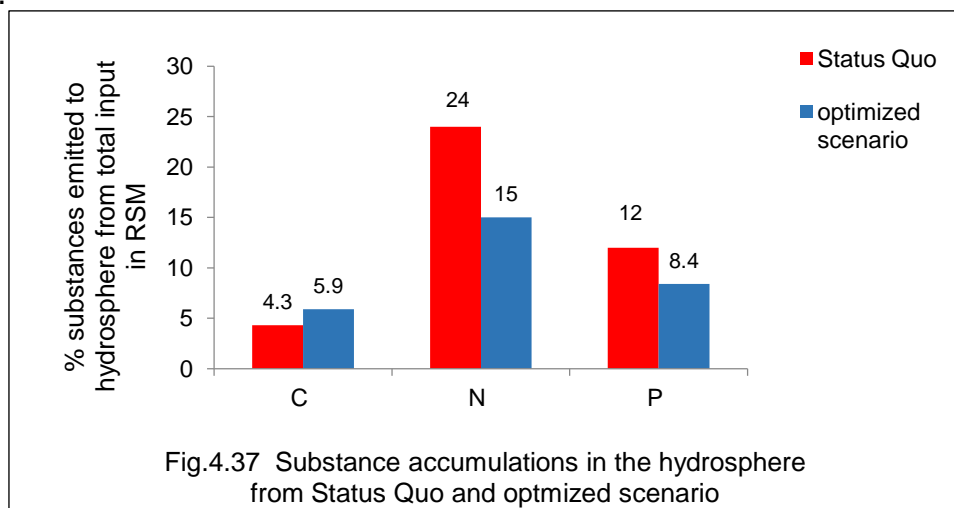

The optimized scenario distributes 740 kg/y.ha C, 3.5 kg/y.ha N, and 2.5 kg/y.ha P to accumulate in the farm soil, more than in Status Quo. The percentages of substances distribution to soil are higher than in Status Quo, as shown in Fig. 4.38.

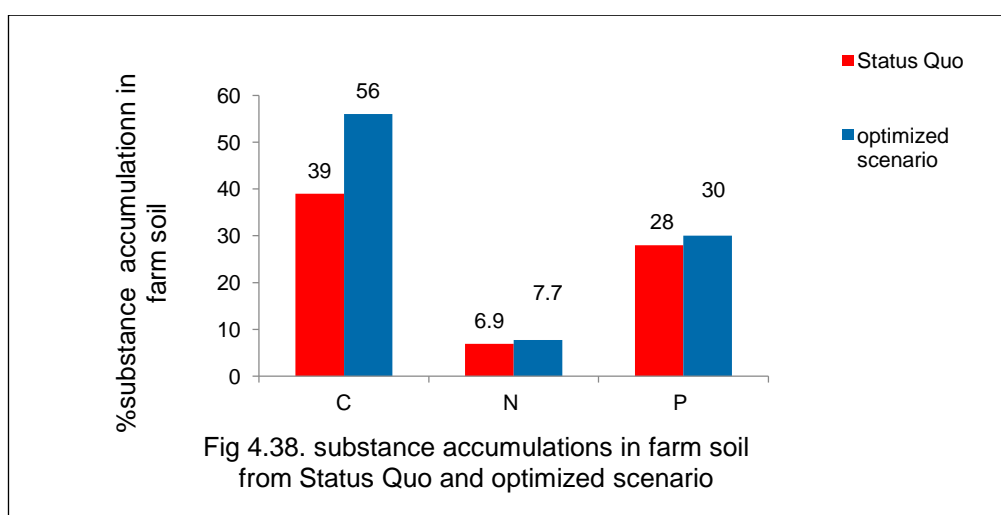

The distribution of substances to useful products i.e. RSM products of optimized scenario are 110 kg/y.ha C, 12 kg/y.ha N, and 0.32 kg/y.ha P, showing that resource efficiencies from optimized scenario are higher than those from Status Quo, as shown in Fig. 4.39.

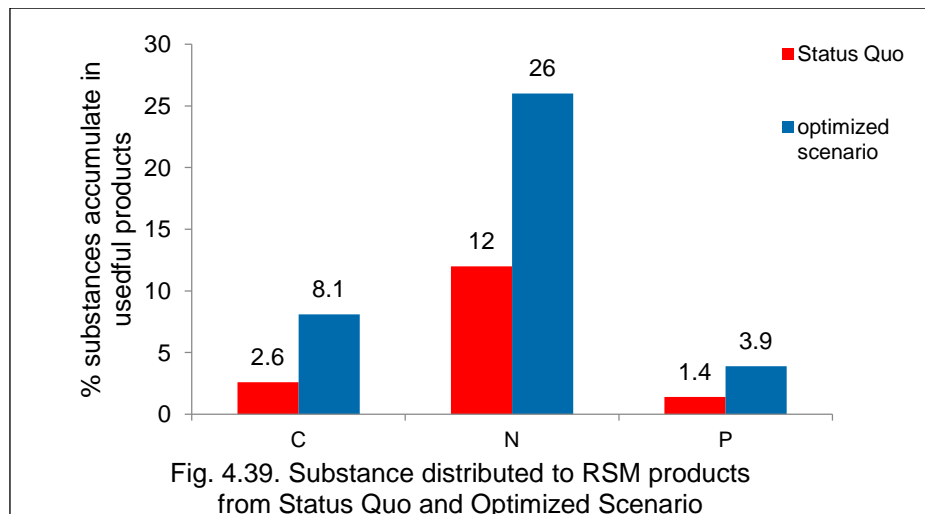

In view of economic profit (Fig. 4.37), Farmers need 170 USD/y.ha for operation costs, e.g. materials or labour, to produce the supplementary products as well as 83 USD/ha for installing a biogas unit at the beginning. Afterwards, yearly investments for operation and labourers are reduced to 170 USD/y.ha, i.e. higher than that of Status Quo. Nevertheless, with this investment, the optimized scenario results in 610 USD/y.ha of net profits for the farmer, i.e. higher than in Status Quo and all scenarios, as shown in Fig. 4.40.

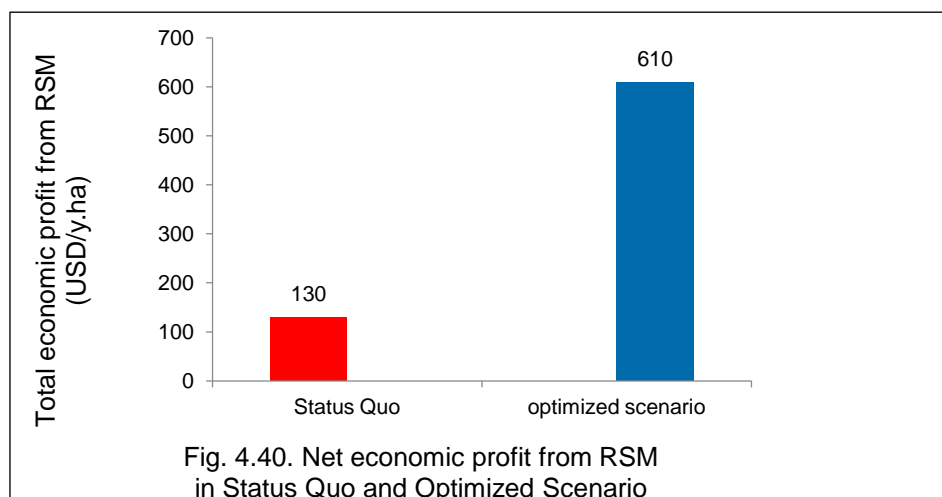

## **4.2. Answers of research Questions**

### 4.2.1. How to define the model farm (Status Quo)?

To complete the analysis of the model farm "Status Quo" by Material Flow Analysis (MFA), System boundaries were defined. The boundary of the spatial system was the space over the ground for rice straw production, usage, and removal on 1 ha of an exemplary small-farm in Thailand. Farm soil, pedosphere, hydrosphere, and atmosphere are not in the boundary as the system focuses only the dynamics of straw above the ground. The boundary of the temporal System was 1 year.

Straw flows, dynamics, and analysis are the main focus in this MFA. Straw from paddy production is defined as data input for MFA calculation. Other data input is only used for completing material balances for straw production and conversion regarding its chemical and biochemical reactions. As all materials and products are either consumed or traded, they do not remain in the system, the stock in the system is therefore defined as 0. Stocks from the environment, i.a. farm soil, atmosphere, as well as undefined hydrosphere and pedosphere exist to observe pollutants and substance accumulation.

The summary of input flows, outflows and stocks are shown in Table 4.7.

Table 4.7. Input flows, output flows, and stock of model Status Quo

Type of flows or stocks	meaning	Examples
Input flows	materials for producing straw and RSM products	flows of CO <sub>2</sub> , fertilizers, substances from soils
Output flows	products from straw utilization in RSM	Livestock weight gain, traded straw
stock of RSM system	none	none
stocks of environmental system	stock of materials of substances in environment	stocks of pollutants in the atmosphere, stocks of substances in farm soil

#### 4.2.2. How to model RSM in small Thai farms by MFA, SFA, EA?

The processes in the model RSM in a small Thai farm are set according to the farm's description, collected from statistic and literature reviewing, as well as interviewing. Based on Material Stoichiometry and Material balances of straw production and utilizations, process equations are defined, created and developed in order to analyze straw flow and its dynamics. The equation of each process represents each process unit of RSM. Cattle, a rumen-Livestock, is used as a tool in part of the processes converting straw to end products. Data Output analysed by STAN are RSM products e.g. Weight gain of livestock protein, including waste converted from straw burning and from straw using, and finally emitted into the atmosphere, as well as accumulated in farm soil and hydrosphere. Costs and profits are calculated from the costs of materials, labour, and other operational costs. The profits are calculated from either market values of traded products or from return values of RSM products that farmers use instead of buying commercial products on the market. The software STAN is used for evaluating and comparing material, elemental, and economic differences between "Status Quo" and the improved Scenarios. Calculated values are reported in 2 significant digits.

#### 4.2.3. How to select the data for MFA, SFA, EA?

Statistic data are drawn from International Organizations, Thai authorities as well as scientific literature. The spatial ratio of straw-burning per rice-cultivated area was precisely visualized by Satellite Imageries and GIS data combined with data from surveying and interviewing. Laboratory data of mushroom and spawn composition, as primary data, are also used in this study.

#### 4.2.4. How to reduce uncertainty?

Referring to the guidelines of IPCC (2006), minimizing uncertainties in this study is done by data collection: choosing the most suitable and representative data for the study conditions. In this study, specific data for e.g. type of plants or animals, methods, regions, climate, and year from scientific Institutions or Thai authorities are given priority e.g. the Office of Agriculture Economics (OAE), Department of Pollution Control (DPC), Bank of Thailand (BOT), etc.

In the calculation process, STAN can also reduce uncertainty and contradictions by data reconciliation in order to reconcile data values to be inside a range of 95% interval (i.e. normal distribution).



#### 4.2.5. What are appropriate criteria to select technologies for improving scenarios?

The concept of selected technology is "Simplicity - Higher income - Lower emissions". To find technology contributing to the solution of RSOB's problems, the criteria for selecting technologies are combined from the classified criteria, as follows:

A) criteria for stake holders (farmer): Processes must be easily handled without sophisticated machines, labourers, and knowledge.

B) criteria for economics: Farm income must increase in order to motivate farmers to operate the processes since farmers are the decision makers and are operating the technologies by themselves. At the same time, the investment should be feasible and realistic for a small farm scale

C) criteria for the environment: it should contribute to the solution of air pollution from RSOB e.g. GHG, CO, Haze. At the same time, should reduce the problem of nutrient loss from soil due to RSOB.

D) criteria for resource management: the technology should increase resource efficiency of RSM in order to reduce the loss of substances and use them effectively in the RSM products. Furthermore, the technology should improve the amount of soil nutrients in farms in which they are depleted.

#### 4.2.6. What should be the criteria to combine technologies for an Optimized scenario?

The main concept is to find the optimize solution from the combine technologies in view of the economics, resource efficiency, environment, public health and by motivating farmers through economic benefit gain from increasing of farm products. Using of combination technologies should reducing or eliminating hazardous pollutants e.g. CO, PM. All technogies must be financially and practically possible for handling, mainly by farmers and household members.

#### 4.2.7. What are suitable indicators for assessing the effectiveness of each scenario?

In this study, 3 suitable indicators are used for assessing model effectiveness. The first indicator is the environmental impact, e.g. emissions of air pollutants. The second indicator is the effect on resource management by farmers in terms of resource efficiencies of substances utilized in useful RSM products. The last indicator is the economic benefit from trading or using RSM products by farmers.

### **4.3. Interpretation**

As shown above, the scenarios have different advantages and disadvantages. The following interpretation of the analysis' results helps to combine the most appropriate technologies in order to identify the most effective optimized scenario.

#### **4.3.1. Interpretation in terms of environment**

From an environmental perspective, all scenarios can eliminate PM and CO emissions, reducing respiratory health problems at individual and regional level caused by these pollutants.

In view of GHG emission by scenario analysis, all scenarios emit less CO<sub>2</sub> and N<sub>2</sub>O than in Status Quo. Although GHG emissions from scenario Food are already lower than in Status Quo, Scenario Food unavoidably emits more CH<sub>4</sub> due to the anaerobic decomposition of organic matter from SMS and manure used as soil conditioners and organic fertilizers. In scenario Fodder and Energy, the large amounts of straw feed for livestock also cause relevant amounts of CH<sub>4</sub>, hence increasing the total GHG compared to Status Quo. Scenario construction has the lowest emissions of air pollutants, since all substances usually emitted by RSOB are trapped into straw brick due to the slow rate of microbial degradation because of low N content, as well as low moisture and low O<sub>2</sub> (mentioned in Chapter 2). Therefore, straw brick is an excellent long term material for trapping C from straw.

The substances accumulating in the hydrosphere in Status Quo and all improved scenarios are highly diluted by the tremendous volume of water used in rice production (max. 0.75 mg/l N and 0.076 mg/l P from Status Quo and all improved scenarios). Therefore, those concentrations are less than the minimal standard of Nitrogen and Phosphorus set by the Department of Pollution Control (PCD) Thailand for wastewater released to natural water resources from agriculture. Hence, these accumulations are not relevant.

#### 4.3.2. Interpretation in terms of resource management

The Efficiency of resource management is indicated by amount of substance distribution into useful products from the RSM system. At the same time, substance depletion in soil is a problem in Thailand. Therefore, the assessment of soil fertility according to available substance stocks in soil is another relevant assessment.

##### 4.3.2.1. Level of resource efficiency

In view of substance accumulation in useful products indicating the level of resource efficiency of scenario analysis, Scenario Construction offers the best results of C, N and P distributed in its useful product (straw brick). At the same time, scenario energy also provide best result of N efficiency. Scenario Fodder and Energy absorbed more C and N into their RSM products (livestock and biogas) than scenario Food due to higher yield of Protein produced from livestock and minor N content in biogas. Unfortunately,  $\text{NH}_3\text{-N}$  from the manure of livestock in scenario Fodder also score high N losses from volatization. Optimizing the RSM system by trapping this N loss by absorbing it into another RSM product is a good solution to increase its N efficiency.

##### 4.3.2.2 Level of availability of plant nutrients in soil

Substance accumulations in soil indicate the stage of soil nutrients, from which one can estimate the level of soil fertility, especially as the soil of rice farms in Thailand has a deficiency in nutrients as mentioned in Chapter 1 and 2.

Adding organic matter into soil can improve nutrient availability for plants as the organic matter is degraded by soil microorganisms, slowly releasing substances to soil. Hence, the amounts of available nutrient substances are maintained for plants instead of being leached or eroded away by water as inorganic fertilizers would be or being bound with metal ion in soil.

In view of C, OC from RSM's waste and residues accumulation in soil has both positive and negative effects. The negative effect of adding high amounts of organic fertilizer in flooded soils during rice cultivation is that  $\text{CH}_4$  emissions from the anaerobic fermentation in soil are increased due to adding of higher organic C. Furthermore, the large accumulation of C to soil in Status Quo (510 kg/y.ha) and all scenarios (460-820 kg/y.ha) sounds critical. However, the maximum amount of C accumulation in soil from this study is still a very small amount compared to the C stock in top layer fertile-soil from forests, e.g. 200 tons C/ha (mentioned in Chapter 2). To reach the level of fertile soil from agricultural soil, generally containing C 50% of C in fertile soil from forest, it will take more than 100 years. Furthermore, carbon sequestration by agricultural soil helps to remove C from the atmosphere and turn it to stable C in soil as well, comparable to the explanation of N accumulation in soil in this study (2.8-3.6 kg/y.ha), which is only approx. 0.035-0.044% of total N in forest soil.

Considering total P (2.2-2.5 kg/y.ha from all scenarios), the accumulation amount per year is 3% of available P in average forest soil. Therefore, the amount of P accumulating in soil year by year is still small amount.

Furthermore, Farmers generally add N and P for paddy grain production, another unit in the farm referring to farm definition in Chapter 3. Base on nutrient composition in rice plant and paddy grain,. 54-58 kg N/ha and 12 kg P/ha are uptaken by rice plants for producing paddy grain in this exemplary farm. Amounts of N and P that plants need are higher than the those released from RSM system to soil. Therefore, the amounts of N and P from RSM unit will not accumulate but rather compensate parts of N and P rice plants need to produce rice grain from this soil in the "paddy grain production unit" in the model farm. Hence, the demand for chemical fertilizers should be reduced.

For this reason, all scenarios can remedy the nutrient depletion in soil. Concerning plant nutrients from substance accumulations in soil, scenario Food therefore provides for the highest amount.

#### 4.3.3. Interpretation in term of economics

The prices of products and production costs are the most important factors to indicate the economic profit. All improved scenarios result in higher profits than Status Quo. Scenario energy offers the highest profit from the trading of livestock protein. and also helps farmers to save money by not having to purchase LPG for HH consumption (equaling 80% of the LPG consumed by one person for cooking 1 meal/day for a whole year) while Scenario construction on the other hand generates the lowest profit due to high yearly investment costs on material and labour.

Market demand can influence the market price. There is e.g. a constant high demand for mushrooms on domestic and international markets compared other RSM products.

Cost factor is another factor influencing economic profit. The maximum costs of scenario energy, to be spent on construction and material, is 15% of farm's agricultural income. Therefore, farmers can either spend their money reserve or get loans from community cooperatives. Later, they will only have to replace some materials at a cost of 5% of their agricultural income. In contrary, scenario construction would require 180% of the farmer's agricultural income every year for material, electricity, and labour. In view of farmer's income, scenario construction is not feasible if all straw would be processed to straw brick.

In view of labour demand, Scenario Food does not require any supplementary labour. Scenarios Fodder and Energy need 2 labourers during the construction phase of its treatment unit. By contrast, scenario Construction needs skilled labourers to mix materials properly as well as to handle the machines.

Furthermore, the production scale in its scenario is too big for operating by small farm holders. The farmers would need to prepare large amounts of mortar materials for brick production and hire labourers for producing all straw bricks. On top of that, the quality of straw bricks needs to be quality-controlled in order to meet official quality standards before being sold at large scale on the market. This scale of production is therefore feasible only for a professional manufacturer but not at HH scale.

#### .4.3.4. Interpretation of integrative technologies in Optimized Scenario

Based on the above criteria to select and combine appropriate technologies, the most effective method is producing straw brick for HH uses in order to trap a number of substances into the brick, producing mushroom and using its SMS for improving soil fertility, as well as using livestock as a pre-treatment unit to trap more C in manure for producing biogas. To reduce N loss from biogas slurry, N and P are additionally trapped by duckweed then used for feeding tilapia fish.

With the combinations of technologies in the Optimized Scenario, the model's effectiveness in terms of environment, resource management, and economics is improved. It is proven that this scenario can contribute solutions to the problems of traditional RSM.

At individual level, The improving of resource efficiency by increasing of substance transferring from straw into RSM products results in farmers getting direct benefits from higher economic profit. Farmers also get indirect benefits from the reduction of N and P losses in farm soil resulting in the improvement of soil fertility.

Reducing air pollutants from the optimized scenario also contributes to the solution of environmental and health problems. At regional level, the community's health is improved by the relevant reduction of PM and CO. At international level, the reduction of GHG emissions also contributes to the mitigation of climate change.

In order to simplify the models in this study, the system is not representing the whole farm system but only the rice straw management system. Data on material's compositions, quantification, costs or prices, etc, are cited from various resources in order to fulfil the MFA, SFA, and EA from complex biochemical processes. Therefore, the data set used in this research unavoidably contains some inconsistencies. At the same time, each data also has its own uncertainty, e.g. the amounts of straw produced and collected by different harvesting techniques, i.e. manual versus machine cutting. In addition, different methods of calculation and interpretations of those data also result in different data uncertainties. The uncertainty range of data input in this research covers the incompleteness or uncertainty of available data.

## Chapter 5

### Conclusion and Recommendation

Material Flow Analysis (MFA), Substance Flow Analysis (SFA) and Economic Analysis (EA) of model "Status Quo" is developed and evaluated via STAN in order to simulate Rice Straw Management (RSM) and its economics on small farms in Thailand. The uncertainties in MFA are minimized by using the average values of quantitative statistical data, together with experimental data and visualized data by Satellite Imageries. Default data from international organizations are also used in case the specific data do not exist. Descriptions of farm management and of the farmer's household have been collected from statistical and literature reviews as well as personal interviewing. Calculated values are reported in 2 significant digits.

In Thailand, farmers normally cultivate rice twice a year. They rent both labourers and machines for cultivating and again for harvesting. Herbicides or pesticides are used only when needed. Rice straw is partly collected for feeding cattle while tethered at home, especially during the dry season. The remaining is left on the soil together with rice stubble followed by tillage to prepare the soil for the next cultivation. Farmers also sell straw for baling if a professional baler comes on-site and do tillage the remaining straw and stubble that are left over on the field. The chemical fertilizers e.g. Urea (46-0-0) and Ammophos (16-20-0) are used alongside manure as organic fertilizer. Most of small farms buy cattle to be raised for meat production from 4 months to 1 year, then resell them as live-cows to dealers who come to buy on-site. Small farm holders traditionally managed livestock production by tethering the cattle in small plots nearby their house or paddy fields. Other animals raised on their farms are buffaloes, pigs, chicken, ducks, and fish depending on the household. Most of them have a pond fed by canal water. Water from the pond is a backup for farm and household consumption. Sometimes, farmers catch wild fish for their own consumption. The main farm income is from selling paddy grain, cattle and other animals they raise.

Referring to the statistic data of the Office of Agriculture Economics (OAE) Thailand for 2011, the average size of small farms was 4.0 ha. 52% of these farms were cultivating rice on 75% of the farm area (3.0 ha). The data from the Pollution Control Department (PCD) in 2009 showed that water consumption for rice cultivation was 13000 m<sup>2</sup>/y.ha. The farms' wash out contaminated with herbicides and pesticides was on average 0.000046 kg/y.ha, which DPC assessed as 0 kg/ha. At an exchange rate of 30 BHT per USD, the net annual income of farmers in 2011 from agriculture was 1900 USD/HH, i.e. 37% of their total income (5200 USD/HH). In this year, 3200 kg paddy grain/y.ha were produced. 73% of their ruminant livestock was cattle for meat production. The average number of Cattle was 1.0/HH. Market price of a live-cow Fresh Weight (FW) was 1900 USD/tons. The market prices of urea and Ammophos fertilizer were 0.50 USD/kg and 0.52 USD/kg.

To define the RSM model of an exemplary farm, the spatial system of a small farm is defined as 1 ha containing Rice Straw management units (RSM): straw production, uses, and removal. Its temporal System is defined as 1 year. Straw from paddy production is data input for calculating all flows in the MFA. Process units in the system are defined from the description of rice straw management on Thai small farms, i.a. straw production, straw distribution, livestock production, manure collecting, and chemical distribution, collected from statistic data as well as from interviewing. Cattle is used as a tool for converting straw into end products. Input flows are substrates for straw production and utilization as well as for producing RSM products. Output flows are livestock weight gain and traded straw. All substrates are used to fulfil the production potential of the system. At the same time, all RSM products without exception are traded yearly. Therefore, no stock of neither substrates or products exists. Based on stoichiometry and material balances, process equations are defined and developed. The equations in each process of Status Quo represent the traditional RSM of straw in Status Quo. The effectiveness of the system is indicated from the amount of pollutant emissions, the percentage of resource efficiency of substances being distributed into the RSM products, including economic profit the farmer gains.

Based on MFA analysis for Status Quo of an exemplary farm in 2011, 3200 kg straw is produced. 1500 kg of straw is burnt by RSOB, which emits 3800 kg CO<sub>2</sub>e, 110 kg CO, and 11 kg PM into the atmosphere. Substance distribution into products are only 2.6%C, 12%N, and 1.4%P of its total input. The economic profit from Status Quo is 130 USD/a from trading 27 kg DM of livestock weight gain as well as 45 kg un bale straw, equal to 6.8% of the agricultural income. The RSOB in traditional management causes the problems from emission of GHGs and hazardous air pollutants e.g. CO, PM. It also causes nutrient loss to the atmosphere.

As the concept of technology is "Simplicity - Higher income - Lower emissions", suitable technologies for small farms are selected. They must be easily handled by the unskilled farmers without sophisticated machines, as well as labourers. At the same time, they must increase resource efficiency to produce RSM products as well as increasing soil nutrients to raise farm income thus motivating farmers to operate them as farmers are the decision makers and operate the technology by themselves. The investment for technology should be affordable for small farm holders. Most important is the suitable technology for the environment. It should contribute a solution for environmental problems from RSOB e.g. GHG, CO, Haze.

Based on the criteria above, production of food (straw mushroom), fodder (U-lime straw), energy (biogas), and construction material (straw brick) from straw are selected. Scenario analysis is to observe weaknesses or strengths of each technology when replacing RSOB in Status Quo. Stock in scenario fodder is a construction unit of straw treatment units while that in scenario energy are construction units for straw treatment and biogas. Stocks in scenario food and construction are defined as 0 as materials neither

substrates for RSM nor products remain after 1 year. Same amount of straw usually burnt in RSOB is utilized to produce different products for each scenario. Substrates and materials for each scenario are added in order to fulfill the production.

From scenario analysis, CO and PM from straw burning are eliminated by selected technology used in all scenarios thus reducing health problems. Scenarios food and construction reduce GHG emissions by 700 and 2,100 kgCO<sub>2</sub>e, i.e. lower than Status Quo, while scenario fodder and energy emit higher GHG than Status Quo due to a higher amount of CH<sub>4</sub> being produced from livestock's rumen. Scenario construction offers the best improvement on substance distribution into its RSM products as well as lowest emission of air pollutants. Scenario food offers the highest amount of substances accumulation in soil as soil nutrient. The economic profit in all scenarios are 4.0-4.5 times higher than in Status Quo. Scenario energy offers the best economic profit while scenario construction is the only scenario that needs yearly investment costs of about 180% of the yearly agricultural income of farm's household. This scenario is therefore neither financial feasible nor affordable for small farms to produce the product at large scale.

The appropriate technologies above are combined and optimized for best results in terms of environment, resource efficiency, and economic profit. The most effective combination is producing a few straw bricks for farm and HH use in order to trap a number of substances, converting substances from straw into mushroom's tissue, using Straw Mushroom Substrate (SMS) for improving soil fertility and as supplement fish feed, using livestock to convert straw substances into its tissue and acting as pre-treatment unit before producing biogas to trap further C and other substances into biogas. Afterward, using duckweed to trap N and P from biogas slurry, then use it for tilapia fish feed to convert the substances from duckweed and SMS into its tissue.

With the combinations above, the model's effectiveness in terms of environment, resource management, and economics is improved. Compared to Status Quo, emissions into the atmosphere of 800 kg CO<sub>2</sub>e are avoided while CO and PM are eliminated. The percentages of substance accumulation in soil to increase hence the amount of soil nutrients is also improved. Resource efficiency as percentages of substances' distribution in the RSM products from total input for producing and utilizing straw is also increased from 2.6 %C, 12%N, and 1.4%P in Status Quo, to 8.1%C, 26%N, 3.9%P in optimized scenario. The highest investment at the first year, for installing biogas unit as well as operation cost, is only 13% of the household income from agriculture. On top of that, the economic profit from RSM in optimized scenario increases 4.7 times compared to Status Quo.



This effectiveness contributes to solutions at different levels. At individual level, the farmers benefit directly via economic profits from higher resource efficiency of RSM products, and indirectly from the reduction of N and P depletion in farm soil resulting in the improvement of soil fertility. At regional level, the community's health is improved by the reduction of the hazardous pollutants from RSOB i.a. PM and CO. At global level, the reduction of GHG emissions contributes to the mitigation of climate change.

According to this study, at least one or two technologies can already improve RSM in different perspectives of resource management at individual level. However, it is the optimized scenario that brings the highest economic profits, and increases resource efficiency as well as nutrients in the farm's soil. It also contributes environmental benefits to the community as well as at regional level. Ideally, the optimized scenario would be implemented by farmer's cooperatives - if any.

The government can also motivate farmers to implement this scenario by supporting village funds or cooperative funds for machinery or paying subsidies for reducing GHG emissions directly to the farmer, as e.g. the Thai government used to do for the construction costs of biogas digestors for small and medium scale animal farms from 1999-2003.

Referring to the comprehensive data processed by MFA via STAN on small farms in Thailand, it can be concluded that MFA is a potential tool for analyzing, evaluating, and investigating not only the present situation with all its issues, but also for proposing solutions for resource management in Thailand as well as in other emerging economies.

However, it was challenging to implement the STAN software which is aimed at straightforward industrial processes to simulate agricultural processes in open nature in all their complexity. Therefore, a more complete and varied database would assist STAN's performance and result in further perspectives to raise people's awareness for environmental problems stemming from ineffective resource management. The present study already guides stakeholders to choose more efficient RSM solutions by offering micro-economic benefits to them with positive external effects on the environment.

## References

- Abdella A.A.F. 1990. The Effect of Ammonia on *Oreochromis niloticus* (Nile Tilapia) and its Dynamics in Fertilized Tropical Fish Pond. in 7th Annual Administrative Report, Pond Dynamics/Aquaculture CRSP 1989. Egna H.S., Bowman J., and Mcnamara M.eds. Oregon State University. p. 52.
- Ahlawat O.P. Singh R., and Kumar S. Evaluation of *Volvariella volvacea* Strains for Yield and Diseases/Insect-Pests Resistance Using composted Substrate of Paddy Straw and Cotton Mill Wastes. Indian J. Microbiol. 2011. 51 (2). 200-205. in
- Stamets P. and Chilton J.S. 1985. The Mushroom Cultivator: A Practical Guide to Growing Mushrooms at Home. Agaricon Press. Washington. p. 214.
- Ahmad M.H. , Abdel-Tawwab M., and Khattab Y.E. Effect of dietary protein level, initial body weight, and their interaction on the growth, feed utilization, and physiological alterations of Nile tilapia, *Oreochromis niloticus* (L.). Aquaculture. 2010. 98 (3-4). 267-274.
- Akinyele B.J. and Adetuyi F.C. Effect of Agrowastes, pH and Temperature Variation on the Growth of *Volvariella volvacea*. Afri. J. Biotechnol. 2005. 4 (12). 1390-1395.
- Allam M.E., Garas G.L., El Kady H.G. Recycled Chopped Rice Straw-Cement Bricks: Mechanical Fire Resistance&Economical Assessment. Aus. J. Basic. Appl. Sci. 2011. 5 (2). 27-33.
- Ananthakrishnan R., Sudhakar K., Goyal A., and Satya S. Economic Feasibility Of Substituting LPG With Biogas For MANIT Hostels. Int. J. Chem.Tech. Research. 2013. 5 (2). 891-893.
- Anurak B. Study on Plant Nutrient Absorption (Phosphate) in Soil and Plant Nutrient Concentration (Phosphate, Nitrate, Ammonia-Nitrogen) in Water and Water Quality (DO, BOD). 2010. Proceedings of 1st Thailand INWEPF Symposium "Multiple Roles of Paddy Fields Related to Integrated Resources Management. pp.36-53.
- Anderson L.D., Faul K.L., and Paytan A. Phosphorus Association in Aerosols: What can they tell us about P bioavailability? Mar. Chem. 2010. 120. 44-56.
- Ansal M.D., Dhawan A., and Kaur V.I. Duckweed Based Bio-remediation of Village Ponds: An Ecologically and Economically Viable Integrated Approach for Rural Development through Aquaculture. Livestock Research for Rural Development. 2010. 22. Article #129.
- Anuraktipan Y. 2012. Monitoring and Inventory Soil Carbon Loss from Soil Erosion. An Assessment Report for Land Developing Department, Thailand. Bangkok. 153 pages (Thai).
- Attanant T. 2007. Paddy Soil Science. Department of Soil Science. Faculty of Agriculture. Kasetsart University. Bangkok. pp. 333-340 (Thai).
- Ayag G., Todd A., and Brooke, P.C. Enhanced biological cycling of phosphorus increases its availability to crops in low-input sub-Saharan farming systems (2006). AGRIS. 2013. 38 (1). 81-90.
- Bacha J., Freel J., Gibbs A., Gibbs L., Hemighaus G., Hoekman K., Horn J., Ingham M., Jossens L., Kohler D., Lesnini D., McGeehan J., Nikanjam M., Olsen E., Organ R., Scott B., Sztenderowicz M., Tiedemann A., Walker C., Jones J.L.J., Scott D., and Mills J. Diesel Fuel . 2007.Diesel Fuels Technical Review. Chevron Corporation. USA. 116 pages.
- Banmeung. Organic fertilizers for soil. Interviewing of Deputy Head of Department for land development. Banmeung Newspaper (Thai). August 2010. Thailand.
- Batjes N.H. Total C and N in soils of the world. Eur.J. Soil Sci.1996. 47. 151-163.
- Bechara M. A. 2007. Alternative Mushroom Production System using Non-Composed Grain-Based Substrates. A Thesis in Agricultural and Biological Engineering. Copyright 2008. ProQuest Information and Learning Company. MI. pp. 156-157.

- Bernoux M., Cerri C.C., Neill C., and de Moraes J.F.I. 1998. The use of stable carbon isotopes for estimating soil organic matter turnover rates. *Geoderma*. 82: 43-58. in Manzoni S. and Porporato A. Soil carbon and nitrogen mineralization: Theory and models across scales. *Soil Biology & Biochemistry*. 2009.41. 1355–1379.
- Biro J. 2013. Influence of Dietary Lipid Sources and Altering Feed Selenium Level on The Fillet Composition of African Catfish and Nile Tilapia. Theses of Doctoral (Ph.D.) Dissertation. Faculty of Animal Science. Kaposvar University. Kaposvar, Hungary. 36 pages.
- Biswas M.K. and Layak M. Techniques for Increasing the Biological Efficiency of Paddy Straw Mushroom (*Volvariella Volvacea*) in Eastern India. *Food Sci. Technol*. 2014. 2 (4). 52-57.
- Busman L., Lamb J., Randall G., Rehm G., and Schmitt M. 2009. The Nature of Phosphorus in Soils. University of Minnesota: extension. [www.extension.umn.edu](http://www.extension.umn.edu).
- Buswell J.A. and Chen M. Cultivation, Biochemical, Molecular Biological and Medical Aspects of the culinary Medicinal Straw Mushroom *Volvariella volvacea* (Bull.:Fr.) Singer (Agaricomycetideae). *Int. J. Med. Mushrooms*. 2005. 7. 157-166.
- Center for Coastal Physical Oceanography (CCPO). 2003. Earth Surface Realm. in *Studying Earth's Environment from Space*.
- Chang C.H., Liu C.C., and Tseng P.Y. 2013. Emission Inventory for Rice Straw Open Burning in Taiwan Based on Burned Area Classification and Mapping Using Formosat-2 Satellite Imagery. *Aerosol. Air. Quality Res*. 2013. 13. 474-487.
- Chang S.T. and Quimo T.H. 1989 *Tropical Mushroom: Biological and Cultivation Method*. Chinese University Press. Hong Kong. pp. 119-163.
- Chau L H. Biodigester effluent versus manure, from pigs or cattle, as fertilizer for duckweed (*Lemna* spp.). *Livestock Research for Rural Development*. 1998. 10. Article #27.
- Chaudhry A S 1998a Chemical and biological procedures to upgrade cereal straws for ruminants. *Nutritional Abstracts and Reviews*. Volume 68: 319-331. in Trach N.X., Mo M., and Dan C.X. Effects of treatment of rice straw with lime and/or urea on its chemical composition, in-vitro gas production and in-sacco degradation characteristics. *Livestock Research for Rural Development*. 2001. 13 (4). Article #35.
- Cha-Un N., Fusuwankaya K., and Taoprayoon S. 2010. Soil Organic Carbon Stock and Rate of Carbon Dioxide Emission of Abandoned Agricultural Land. *Climate Thailand Conference*. 19-20 August 2010. Bangkok. 448-460.
- Cheewaphongphan P., Garivait S., Pongpullponsak A., and Patumsawad S. Influencing of Rice Residue Management Method on GHG Emission from Rice Cultivation. *World Academy of Sci. Eng. Technol*. 2011. 5. 10-27.
- Cheewaphongphan P., Garivait S., and Pongpullponsak A. Inventory of Pollutions from Rice Field Residue Open Burning based on Field Survey. 2011 2nd International Conference on Environment Science and Technology. IPCBBE. 2011. 6.V2-93-V2-97
- Chenost M. and Kayouli C. 1997. Chapter 4. Urea Treatment. in *Roughage Utilization in Warm Climates*. FAO. Rome.
- Chidthaisong A., Kanokkanjana K., Gravait S., Bonnet S., Towprayoon S. 2011. Country Report on Rice Cultivation Practice: Thailand. Oral Presentation. Asia-Pacific Network: Expert meeting. 2-3 June 2011. Bangkok.
- Chinapong T. 2014. Aquatic Polyculture base on Organic and Sufficient Agriculture. Taksin University. Songkla. pp. 1-7 (Thai).

Chinawerooch S., Rakklin N., Poolpanichupattam K., Changnoi A. Baling Straw's Project: Cost assessment from a demonstration of baling 2014 (Thai). Chainat Research Center for Livestock Development. Ministry of Agriculture and Cooperatives. Thailand.  
[http://nccn-cnt.dld.go.th/cnt\\_new/index.php/2015-07-25-12-34-58/51-2015-10-09-07-00-34](http://nccn-cnt.dld.go.th/cnt_new/index.php/2015-07-25-12-34-58/51-2015-10-09-07-00-34)

Choenchooklin S. Ud-ai W., Sanyong S., and Amarakul W. Monitoring and Evaluation of Rice Straw Burning's Carbon Dioxide Quantities in the Lower-Northern Plain Using Satellite Imageries. Workshop on the Progress of Theos Satellite and Geo-Informatics for Development. 7-8 September 2010. Khonkaen. Thailand. pp. 37-44 (Thai).

Choi K.C., Woo J.H., Kim H.K., Choi J. Eum J.H., and Baek B.H. Modeling of Emission from Open Biomass Burning in Asia Using the BlueSky Framework. *Asian J. of Atm. Environ.* 2013. 7(1) 25-37.

Conrad R. and Rothfuss F. Methane Oxidation in the Soil Surface-Layer of a Flooded Rice Field and the Effect of Ammonium. *Biol. Fertil. Soils.* 1991. 12. 28-32.

Chowhudry M.A.K. and Bureau D.P. Predicting body composition of tilapia. *Fisheries Sci.* 2009. 22(2). 359-385.

Christian T.J., Kleiss B., Yokelson R.J., Holzinger R., Crutzen P.J., and Hao W.M. Comprehensive Laboratory Measurements of Biomass-Burning Emissions: 1. Emissions from Indonesia, African, and Other Fuels. *J. Geophys. Research.* 2003. 108 (D23). 4719-4732. in  
Kanabkaew T. and Oanh N.T.K. Development of Spatial and Temporal Emission Inventory for Crop Residue Field Burning. *Environ. Model. Assess.* 2011. 16.453-464.

Chulalongkorn University (CU). 2005. 1st Progress Report on Atmospheric Study via Satellite. Office of Secretary General, Ministry of Information and Communication Technology. pp. 1-34 (Thai).

College of Tropical Agriculture and Human Resource (CTAHR). 2015. Soil Nutrient Management for Maui County. University of Hawaii at Manoa. [www.ctahr.hawaii.edu](http://www.ctahr.hawaii.edu).

Collin W.J., Stevenson D.S., Johnson C.E., and Derwen R.G. 1997. Tropospheric Ozone in a Global Scale 3-Dimension Langrangian Model and Its Response to NO<sub>2</sub> Emission Controls. *J. Atmos. Chem.* 26. 233-274. in  
US-EPA. 2000. Air Quality Criteria for Carbon Monoxide. US-EPA. Research Triangle Park. NC. pp. 3.3-3.9.

Cong, W.F., van Ruijven J., and Mommer L. Plant species richness promotes soil carbon and nitrogen stocks in grasslands without legumes. *J. Ecol.* 2014. in  
European Commission. Soil nitrogen increased through greater plant biodiversity. *Science for Environmental Policy.* 11 September 2014. 385.

Compostjunkie.com. cited on May 2015. Compost Carbon Nitrogen Ratio: Is It Really That Important?. [www.compostjunkie.com](http://www.compostjunkie.com).

Corsi S., Friedrich T., Kassam A., Pisante M., and de Moraes Sà J. 2012. Soil Organic Carbon Accumulation and Greenhouse Gas Emission Reductions from Conservation Agriculture: A Literature Review. *Integrated Crop Management.* Vol. 16. FAO. Rome. 67 pages.

Council of Engineers (COE) Thailand. 2010. Volumetric calculation for mixtures of construction materials. [www.coe.or.th](http://www.coe.or.th).

Council of Song Peenong's community. cite in August 2015. Pilot biogas digester and cost assessment. Chantaburi, Thailand.  
<https://sites.google.com/site/spgsubcitizen/home>

Cross J. 2012. Duckweed nutritional composition. [www.mobot.org](http://www.mobot.org).

Cui J., Zhang R., Bu N., Zhang H., Tang B., Li Z., Jiang L., Chen J., and Fang C. Changes in Soil Carbon Sequestration and Soil Respiration Following Afforestation on Paddy Fields in North Subtropical China. *J. Plant Ecol.* 2013. 6 (3). 240-252.

de Almeida J.C., Perassolo M.S., Carmargo J.L., Bragagnolo N., Gross J.L. Fatty acid composition and cholesterol content of beef and chicken meat in Southern Brazil. *Rev. Bras. Cienc. Farm.* 2006.42(1). 109-117.

De Datta S.K., Stangel P. J., and Craswell E.T. 1981. Evaluation of N Fertility and Increase Fertilizer Efficiency in Wetland Rice Soils. *Proceeding of Symposium on Paddy Soil.* Institute of Soil Science, Academia Sinica. Science Press. Heidelberg. p. 175.

Deejring S. and Sa-nguanpong W. 2014. Study of organic and conventional rice soil quality for improvement of organic rice production. Research Project. Maejo University and National Research Council. Thailand (NRCT). 89 pages.

Denman, K.L., Brasseur G., Chidthaisong A., Ciais P., Cox P.M., Dickinson R.E., Hauglustaine D., Heinze C., Holland E., Jacob D., Lohmann U., Ramachandran S., da Silva Dias P.L., Wofsy S.C., and Zhang X. 2007. Couplings Between Changes in the Climate System and Biogeochemistry. In *Climate Change 2007: The Physical Science Basis. Contribution of Working Group I to the Fourth Assessment Report of the Intergovernmental Panel on Climate Change.* Solomon, S., Qin D., Manning M., Chen Z., Marquis M., Averyt K.B., Tignor M., and Miller H.L. eds. Cambridge University Press. Cambridge. pp. 501-568.

Department of Alternative Energy Development and Efficiency (DEDE). 2003. Rice in Thailand. Department of Alternative Energy Development and Efficiency. Bangkok. p. 43. in Gadde B., Menke C., and Wasserman R. 2007. Possible Energy Utilization of Rice Straw in Thailand: Seasonal and Spatial Variations in Straw Availability as well as Potential Reduction in Greenhouse Gas Emissions. GMSARN International Conference on Sustainable Development: Challenges and Opportunities for GMS. 12-14 December 2007. Pattaya. Thailand.

Department of Alternative Energy Development and Efficiency (DEDE) Thailand. 2014. Handbook for Biomass Gas Safety. Ministry of Energy. 30 pages (Thai).

Department of Alternative Energy Development and Efficiency (DEDE) Thailand. cited in May 2015. Biogas Production from Farms and Industries (Thai). Ministry of Energy. Bangkok. [http://www2.dede.go.th/km\\_ber/Attach/Biogas-present.pdf](http://www2.dede.go.th/km_ber/Attach/Biogas-present.pdf)

Department of Alternative Energy Development and Efficiency (DEDE), Thailand. cited in May 2015. Potential of Biomass Residue in Thailand (Thai). Ministry of Energy. [http://www.dede.go.th/ewt\\_news.php?nid=486](http://www.dede.go.th/ewt_news.php?nid=486)

Department of Fisheries (DOF), Thailand. 2014. Project on Standard improvement on Tilapia farm for exporting 2011-2014: Traditional knowledge for Tilapia Cultivation. Ministry of Agriculture and Cooperatives. Bangkok. p. 22 (Thai).

Department of Livestock Production (DLD) Thailand. 2012. Thailand. Strategies Report on Beef Production in 2012-2017. Ministry for Agriculture and Cooperatives. Bangkok. 81 pages (Thai).

Department of Pollution Control (DPC) Thailand. 2011. Report on Situation and Management of Pollution from Rice Field. Ministry of Natural Resource and Environment. Bangkok. 87 pages (Thai).

Devendra, C. 1976. Studies in the utilization of rice straw by sheep. IV. Effect of carbohydrate source on the utilization of dietary urea and nitrogen retention Malays. *Agric. J.* 50: 358–70.

Devendra, C. 1980. Non-conventional feed resources in Asia and the Far East. APHCA/FAO Report, FAO Far East Regional Office. Bangkok. 99 pages.

Devendra C. 1985. Non-Conventional Feed Resources in Asia and The Pacific. 2<sup>nd</sup> Edition. Food and Agriculture Organization of the United Nations. Regional Animal Production and Health Commission for Asia, the Far East and the South-West Pacific (APHCA). Bangkok. 149 pages.

Devendra C. 1993. Sustainable Animal Production from Small Farm Systems in South East Asia. FAO. Rome. 131 pages.

Dewanji A. Amino acid composition of leaf proteins extracted from some aquatic weeds. *J. Agriculture and Food Chemistry*. 1993. 41.1232-1236.

Dixon R.K., Brown S., Houghton R.A., Solomon A.M., Trexler M.C., and Wisniewsky J. 1994. Carbon Pool and Fluxes of Global Forest Ecosystems. *Science*. 263. 185-190 in  
Osman K.T. 2013. *Forest Soils: Properties and Management*. Springer Science & Business Media. eBook. p. 177.

Dobermann, A. and Fairhurst T.H. 2000. *Rice Nutrient Disorders & Nutrient Management*. Oxford Graphic Printers Pte Ltd. 191 pages. in  
Promnart P. *The Different Viewpoint of Fertilizer Usage for Rice Production (Thai)*. *Thai Agri. Research. J.* 2001. 19 (3).  
<http://www.geocities.ws/pisitrice/a3.htm>

Dong J., Wang N., and Zhang X. Fungus Protein-Spent Mushroom Substrate Used to Culture Fish with Better Economic Return. *Sci. Fish. Farming*. 1995. 12. p23. in  
Kangmin L. and Qiuhua W. *Digester Fishpond Interaction in Integrated Biomass System*. Int. Conference on Material Flow Analysis of Integrated Bio-Systems. March-October 2000. Integrated Bio-Systems Network, UNU/IAS Alumni Association, UN Univ., MFA Conference Planning Group, and UNESCO Microbial Resources Centre, Stockholm. Tokyo.

Drake D. J., Nader G., and Forero L. 2002. Feeding rice straw to cattle. Publication 8079 - University of California, Division of Agriculture and Natural Resources. p.3.

Egna H.S. and Boyd C.E. 1997. *Dynamic of Pond Aquaculture*. CRC Press. Boca Raton, Fl. 73-100. pp. 73-107.

Elliott M.A., Nebel G.J., and Rounds F.G. The Composition of Exhaust Gases from Diesel, Gasoline and Propane Powered Motor Coaches. 1955. *J. Air Pollut. Control Associat.* 5(2). 103-108.

Energy Policy and Planning Office (EPPO), Thailand. 2004. Summarized data of Project for supporting Biogas Production in Animal Farms: Part 2. Small and Medium Animal Farms. Department of Agricultural Extension (Thai). Ministry of Agriculture and Cooperatives. Bangkok.  
<http://www.eppo.go.th/vrs/VRS-07-47App.3html>

FAO. *Biogas Technology: A Training Manual for Extension*. Development of National Biogas Programme. September 1996. Consolidated Management Services Nepal (P) Ltd. Kathmandu. 202 pages.

FAO. 2001. *Crop-livestock Technologies*. in *Mix Crop-Livestock Farming. A Review of Traditional Technologies Based on Literature and Field Experiment*, FAO Animal Production and Health. Paper 152. Rome.

FAO. 2001. *Mixed crop-livestock farming. A Review of Traditional Technologies based on Literature and Field Experience*. FAO. Rome..

FAO. 2006. *Plant Nutrition for Food Security: A Guide for Integrated Nutrient Management*. FAO. Rome. page 43.

FAO. 2010. *Characterization of Small Farmers in Asia and Pacific*. Asia and Pacific Commission on Agricultural Statistics: 23rd Session. 26-30 April 2010. Siam Reap. Cambodia.

FAO. 2015. *Soil Fertility*. AGP - Plant Production and Protection-FAO Homepage.

Farag A.A. Radwan H.A., Abdrabbo M.A.A., Heggi M. A.M., McCarl B.A. Carbon Footprint for Paddy Rice Production in Egypt. *Nat. Sci.* 2013. 11 (12). 36-45.

Fowler D., Carmichael G., Collins W., Kuulenstierna J.C.I., Oanh N. T. K, Raes F., Ramanathan V., Schulz M., Shindell D., and Goddard, Vignati E. 2011. Chapter 3. Atmospheric Processes Tropospheric Ozone and Black Carbon Concentrations, Deposition and Radiative Forcing. *Integrated Assessment of Black Carbon and Tropospheric Ozone*. UNEP. pp. 57-89.

Farag A.A. Radwan H.A., Abdrabbo M.A.A., Heggi M. A.M., and McCarl B.A. Carbon Footprint for Paddy Rice Production in Egypt. *Nat. Sci.* 2013. 11 (12). 36-45.

Fazaeli H. and Masoodi A.R.T. Spent Wheat Straw Compost of *Agaricus bioporus* Mushroom as Ruminant Feed. *Asian-Australas. J. Anim. Sci.* 2006. 19 (6). 845-851.

Fidanza M.A, Sanford D.L., Beyer D.M., Aurentz D.J. Analysis of Fresh Mushroom Compost. *Hort. Technol.* 2010. 20 (2). 449-453.

Funakawa S. Watanabe T., Kadono A., Nakao A., Fuji K., and Kosaki T. Soil Resources and Human Adaptation in Forest and Agricultural Ecosystem in Humid Asia. in *World Soil Resource and Food Security*. Lal R. and Stewart B.A. eds. 2012. CRC Press. Boca Raton, FL. pp. 83-107.

Gadde B., Bonnet S., Menke C and Garivait S., Air pollutant emissions from rice straw open field burning in India, Thailand and the Philippines, *Environmental Pollution*. 2009. 157 (5), 1554-1558. in Tripathi S., Singh R.N., and Sharma S. Emissions from Crop/Biomass Residue Burning Risk to Atmospheric Quality. *Int. Research J. Earth Sci.* 2013. 1(1). 24-30.

Gadde B., Menke C., and Wasserman R. Possible Energy Utilization of Rice Straw in Thailand: Seasonal and Spatial Variations in Straw Availability as well as Potential Reduction in Greenhouse Gas Emissions. *GMSARN International Conference on Sustainable Development: Challenges and Opportunities for GMS*. 12-14 December 2007. Pattaya. Thailand.

Garivait S., Bonnet S., and Kamnoed O. 2007. Air Pollutant Emissions from Paddy Residues Open Burning and their Potential for Bioenergy in the Mekong River Basin Sub-Region (Cambodia, Lao PDR, Thailand and Viet Nam). *GMSARN International Conference on Sustainable Development: Challenges and Opportunities for GMS*. 1-5.

Garivait S., Bonnet S., and Kamnoed O. 2008. Air Pollutant Emissions from Paddy Residues Open Burning and their Potential for Bioenergy in the Mekong River Basin Sub-Region (Cambodia, Lao PDR, Thailand and Viet Nam). *GMSARN Int. J.* 2008. 2(4). 169-174.

Garrote, G., Dominguez, H., Parajo, J.C., 1999. Hydrothermal Processing of Lignocellulosic Materials. *Holz als Roh- und Werkstoff* 57, 191–202. in Montgomery L.F.R. and Bochmann G. 2014. Pretreatment of Feedstock for Enhanced Biogas Production. *IEA Bioenergy*. 24 pages.

Godkin N.P., Oliveira F., List R., and Doelle K. 2015. Energy, Carbon Dioxide and Economic comparisons of tilapia sp. nnd cyprinus carpio in aquaponics system. *Revista Científica Vozes dos Vales – UFVJM – MG – Brasil*. 2015.7.1-15.

Gross A. and Boyd C. Ammonia Volatilization from Freshwater Fish Ponds. *Journal of Environmental Quality*. 1999. 28(3). 793-797.

Gunnerson C.G., and Stuckey D.C. (1986) *Integrated Resource Recovery - Anaerobic Digestion*. UNDP Project Management Report No. 5. 154 pages. in Marchaim U. 1992. Chapter nine: Output and its use II. in *Biogas Process for Sustainable Development*. FAO. Rome.

Guo L.B. and Gifford R.M. Soil carbon stocks and land-use change: A meta analysis. *Global Change Biol.* 2002. 8. 345–360. in Fairweather H. and Cowie A. 2007. *Climate Change Research Priorities for NSW Primary Industry: Discussion Paper*. NSW DPI for the Ministerial Advisory Council on Primary Industries Science. NSW. 95 pages.

Gupta U., Sook S. S., Jain A. K., and Gautam A. Fabrication and Performance Evaluation of Paddy Straw Based Biogas Digester. *International Journal of Engineering Research and Applications (IJERA)*. 2012. 2(3). 946-949.

Gupta P.U., Anand G., Karamjeet K. Performance Evaluation of Solid State Digester for Biogas Production using Biologically Pretreated Straw. *Int. J. Agri. Environ. Biotechnol.* 2013. 6 (4). 691-694.

Haekal R. What Is An Emerging Market Economy?. Investopedia. December 3, 2013.

Hao, W. M. and Liu, M.-H.: Spatial and temporal distribution of tropical biomass burning, *Glob. Biogeochem. Cycles.* 1994. 8. 495–503. in  
Koppmann, R., Czapiewski, K.V. and Reid, J.S. A Review of Biomass Burning Emissions Part I: Gaseous Emissions of Carbon Monoxide, Methane, Volatile Organic Compounds, and Nitrogen Containing Compounds. *Atmos. Chem. Phys. Discuss.* 2005. 5: 10455–10516.

Heard J., Cavers C., and Adrian G. Up in Smoke-Nutrient Loss with Burning. *Better Crops.* 2006. 90(3). 10-11.

Herrera J., Rodriguez S., and Baez A. Chemical Composition and Sources of PM<sub>10</sub> Particulate Matter Collected in San Jose, Costa Rica. *The Open Atm. Sci. J.* 2009. 3.124-130.

Holford I.C.B., and Patrick W.H.Jr. 1979. Effects of Reduction and pH Changes on Phosphate Sorption and Mobility in an Acid Soil. *Sci. Soc. Am. J.* 43. 292-297. in  
International Rice Research Institute. 1990. Phosphorus Requirements for Sustainable Agriculture in Asia and Oceania: Proceedings of a Symposium. 6-10 March 1989. International Rice Research Institute. The Philippines pp. 213-214.

Hongkul N., Wanichsathien S., Pianpitak P., Damkam T., Anuraktipan Y. Effects of Vetiver Grasses on Soil Aggregate Stability, Total Organic Carbon, and Polysaccharide on Tha Yang Soil Series. Oral Presentation. Project for Development of Tung Kula Ronghai Areas (Thai). Department of Land Development. Ministry of Agriculture and Cooperatives. 2-4 July 2015. Bangkok.  
<https://www.facebook.com/media/set/?set=a.713996341988659.1073741931.386976171357346&type=3>

Hou, H.H. and Wu, L.C., Respiratory changes in the cultivated mushroom, *Agaricus bisporus*. *Mushroom Sci.* 1972. 9(1), 37–49. in  
Miles P.G. and Chang S.T. 2004. *Mushrooms: Cultivation, Nutritional Value, Medicinal Effect, and Environmental Impact* (Google eBook). CRC Press. Florida. page 77.

Ignosh, J., Stephenson, K., Yancey, M., Whittle, B., Alley, M., and Wysor, W.G. 2009. Virginia Landowner's Guide to the Carbon Market. Virginia: College of Agriculture and Life Sciences, Virginia Polytechnic Institute and State University, Publication no. 442-138. in  
Chiarawipa R., Pechkeo S., Keawdong M., and Prommee W. Assessment of Carbon Stock and the Potential Income of the Carbon Offset in Rubber Plantation. *Burapha Sci. J.* 2012. 17 (2) : 91-102.

International Rice Research Institute (IRRI). cited on May 2015. Composition of Rice Residue. Rice Knowledge Bank.

International Monetary Fund. New Setbacks, Further Policy Action Needed . *World Economic Outlook Update.* 2012. July 16. 1-8.

Intrawech A. and Imsompooch K. 2011. Comparison of Soil Chemical Properties in Tung Kula Ronghai Areas. Department of Land Development. Ministry of Agriculture and Cooperatives. Bangkok. 88 pages (Thai).

IPCC. 1996. *Climate Change 1995: The Science of Global Change.* Cambridge Univ. Press. Cambridge. UK. 572 pages. in  
Wang C. and Prinn R.G. 1998. Impact of emissions, chemistry, and climate on atmospheric carbon monoxide : 100-year predictions from a global chemistry-climate model. MIT Joint Program on the Science and Policy of Global Change Report. 11 pages.

IPCC. 1996. Revised 1996 IPCC Guidelines for National Greenhouse Gas Inventories: Reporting Instructions. A1.1-A1.6.



IPCC. 2000. Carbon Stocks and Flows in Major Biomes. in Land Use, Land-Use Change and Forestry. Watson R.T., Noble I.R., Bolin B., Ravindranath N.H., Verardo D.J., and Dokken D.J. eds. Cambridge University Press. UK. p 375.

IPCC. 2001. IPCC Good Practice Guidance and Uncertainty Management in National Greenhouse Gas Inventories. IPCC.

IPCC 2006. 2006 IPCC Guidelines for National Greenhouse Gas Inventories, Prepared by the National Greenhouse Gas Inventories Programme, Eggleston H.S., Buendia L., Miwa K., Ngara T. and Tanabe K. eds. IGES. Japan.

IPCC. 2007. The Physical Science Basis. IPCC. Solomon S., Qin D., Manning M., Chen Z., Marquis M., Averyt K.B., Tignor M., and Miller H.L. eds. Cambridge University Press. UK. 996 pages.

IPCC. 2007. Climate Change 2007. Contribution of Working Group III to the Fourth Assessment Report of the Intergovernmental Panel on Climate Change. Metz B., Davidson O.R., Bosch P.R., Dave R., and Meyer R.A. eds. Cambridge University Press. UK. 851 pages.

Jacob D. J. 1999. Atmospheric Chemistry. Princeton University Press. Princeton. NJ.. pp. 144-153.

Jacob D. J. 2004. Chapter 10: Stratospheric Ozone. in Introduction to Atmospheric Chemistry. Princeton University Press. Princeton. NJ. 162-198.

Jacobson M.C., Hansson H.C., Noone K.J., and Charlson R.J. Organic Atmosphere Aerosols: Review and State of The Science. Geophys. 2000. 38 (2). 267-294.

Jacobson M.Z. The short-term cooling but long-term global warming due to biomass burning, J. Climate. 2004. 17. 2909-2926. in

Tripathi S., Singh R.N., and Sharma S. Emissions from Crop/Biomass Residue Burning Risk to Atmospheric Quality. Int. Research J. Earth Sci. 2013. 1(1). 24-30.

Jacobson M.Z. 2005. Correction to "Control of fossil-fuel particulate black carbon and organic matter, possibly the most effective method of slowing global warming. J. Geophys. Res. 110. pp. D14105

Jai-aree S. 2007. Effects of Land-use Changes on Soil Organic Carbon in Thailand. An Assessment Report for Land Development Department. LDD, Thailand. Bangkok. 34 pages (Thai).

Jain N. , Bhatia A., and Pathak H. Emission of Air Pollutants from Crop Residue Burning in India. Aerosol and Air Quality Research. 2014. 14. 422-430.

Jain N. Pathak H. Mitra S., and Bhatia A. Emission of Methane from Rice Fields-A Review. J. Sci. Industry. Res. 2004. 63. 101-115.

Jayasuryia M.C.N. and Perera H.G.D. Urea Ammonia Treatment of Rice straw to improve its nutritive value for ruminants. Agricultural Wastes. 1982. 4. 143-150. in

Trach N.X., Mo M., and Dan C.X. Effects of Treatment of Rice straw with Lime and/or Urea on Its Chemical Composition, in-vitro Gas Production and in-sacco Degradation Characteristics. Livestock Research. Rural Dev. 2001.13 (4). Article#35.

Jayasuriya M.C.N and Pearce G.R. The Effect of Urease Enzyme on Treatment Time and The Nutritive Value of Straw Treated with Ammonia as Urea. Anim. Feed Sci. Technol. 1983. 8 (4). 271-281.

Jenkins B.M., Baxter L.L., Miles T.R. Jr., and Miles T.R. Combustion Properties of Biomass. Fuel. Proc. Technol. 1998. 54. 17-46.

Jenkins B.M., Mehlishau J.J., Williams R.B., Solomon C., and Balmes J. Rice Straw Smoke Generation System for Controlled Human Inhalation Exposures. Aerosol. Sci. Technol. 2003. 37. 437-454.

Jensen P.A., Sander B., and Dam-Johansen K. Pretreatment of Straw for Power Production by Pyrolysis and Char Wash. Biomass Bioenergy. 2001. 20. 431-446. in

Chiang W.F., Fang H.Y., Wu C.H., Huang C.J. Change C.Y., Change Y.M., and Chen C.L. The Effect of Oxygen on the Kinetics of the Thermal Degradation for Rice Straw. J. Air. Water. Man. Assoc. 2009. 59. 148-154.

Jørgensen P.J., Plan Energi and Researcher for a Day. 2009. 2nd ed. Biogas-Green Energy: Process • Design • Energy supply • Environment. Digisource Danmark A/S. 36 pages.

Jordan S.N., Mullen G.J., and Murhy M.C. Composition Variability of Spent Mushroom Compost in Ireland. Biores. Technol. 2008. 99(2).411-418.

Kadam K.L., Forrest L.H., and Jacobson. W.A. Rice Straw as a lignocellulosic Resource: Collection, Processing, Transportation, and Environmental Aspects. Biomass and Bioenergy. 2000. 18. 369-389.

Kamwangpreuk J. Cost Analysis of A Cement Block Business in Lampoon Province. Research report on course "Present Economic problem". Faculty of Economics. Chiang Mai University. Chiang Mai. 62 pages (Thai).

Kanokkanjana K. and Garivait S. Alternative Rice Straw Management Practices to Reduce Field Open Burning in Thailand. Int. J Environ. Sci. Dev. 2013. 4(2). 119-123.

Kargbo F.R., Xing J., and Zhang Y. Property analysis and pretreatment of rice straw for energy use in grain drying: A review. Agri. Biol. J. North America. 2010 (3). 195-200.

Katya K., Yun Y.H., Park G., Lee J.Y., Yoo G., and Bai S.C. Evaluation of the Efficacy of Fermented By-product of Mushroom, *Pleurotus ostreatus*, as a Fish Meal Replacer in Juvenile Amur Catfish, *Silurus asotus*: Effects on Growth, Serological Characteristics and Immune Responses. Asian Australas. J. Anim. Sci. 2014. 27 (10). 1478-1486.

Kawaguchi K. and Kyuma K. Paddy Soils in Tropical Asia Part 1. Description of Fertility Characteristics. South East Asian Studies. 1974. Vol. 12 (1). 3-24.

Kawaguchi K. and Kyuma K. Paddy Soils in Tropical Asia Part 6. Characteristics of Paddy Soils in Each Country. South East Asian Studies. 1976. Vol. 14 (3). 334-364.

Keophila M., Thammasom N., and Saenjan P. 2013. Effect of Rice Straw on Rice Yield and Soil Bulk Density. Graduate Research Conference 2013. 22 Feb 2013. Khon Kaen. Thailand. pp. 555-559.

Kerdme S., Penpad R., Daengtongdee S., Kaewkaemtong P., and Banyen-ngam P. 2012. Develop of Biogas Using from Livestock Manure and Agricultural Wastes. Faculty of Science. Rajabhat Petchaboon University and. National Council of Research Thailand. Petchaboon, Thailand. 31 pages (Thai).

Khajareern S. and Khajareern J. 1985. Potential for the Better Utilization of Crop Residues and Agro-industrial By-products. in Animal Feeding in Southeast Asia with Special Reference to Methodology, Equipment, Facilities and Personnel involved as well as Outline of Research Priorities of the Region. in Better utilization of crop residues and by-products in animal feeding: research guidelines. Proceedings of the FAO/ILCA Expert Consultation. Preston T.P., Kossila V., Goodwin J., and Reed S.B. eds. FAO. Rome.

Kim M. and Betram. Surface of the sea is a sink for nitrogen oxides at night. Science Daily. 3 March 2014.

Kimura M., Miura Y., Watanabe A., Katoh T., and Haraguchi H. Methane Emission from Paddy Field.1. Effect of Fertilization, Growth Stage and Midsummer Drainage: Pot Experiment. Environ. Sci. 1991. 4. 265-271. in

Watanabe A. Yoshida M., and Kimura M. Contribution of Rice Straw Carbon to CH<sub>4</sub> Emission from Rice Paddies Using <sup>13</sup>C-Enriched Rice Straw. J. Geophysical Res. 1998. 103 (D7). 8237-8242.

Kimura M., Murase J., and Lu Y. Carbon Cycling in Rice Field Ecosystems in the Context of Input Decomposition and Translocation of Organic Materials and the Fates of their End Products (CO<sub>2</sub> and CH<sub>4</sub>). Soil Biol. Biochem. 2004. 36. 1399-1416.

Khon Kaen Rice Seed Center. cited in Aug. 2015. Nutrient Deficiency in Rice and How to Manage (Thai). Ministry of Agriculture and Cooperatives. Thailand.  
<http://kkn-rsc.ricethailand.go.th/rice/plant/nutrient-fail.html>

Knappert, D., Grethlein, H., Converse, A. 1981. Partial acid hydrolysis of poplar wood as a pretreatment for enzymatic hydrolysis. *Biotechnology and Bioengineering Symposium* 11. 67–77. in  
Mongomery L.F.R. and Bochmann G. 2014. Pretreatment of feedstock for enhanced biogas production. *IEA Bioenergy*. 24 pages.

Knud-Hansena C.F., Battersona T.R., McNabba C.D., Harahatb I.S., Sumantadinatab K., and Eidmanb H.M. Nitrogen input, primary productivity and fish yield in fertilized freshwater ponds in Indonesia. *Aquaculture*. 1991. 94. 49-63.

Koppmann R., von Czapiewski K., and Reid J.S. A Review of Biomass Burning Emissions, Part I: Gaseous Emissions of Carbon Monoxide, Methane, Volatile Organic Compounds, and Nitrogen Containing Compounds. *Atmos. Chem. Phys. Discuss.* 2005. 5. 10455-10516.

Koyama T. Chammek C., Niamrichsand N. Nitrogen Application Technology for Tropical Rice as Determined by Field experiments using <sup>15</sup>N tracer Technique. *Tokyo Technol. Bull.* 1973. 3. 1-79. in  
De Datta S.K., Stangel P. J., and Craswell E.T. Evaluation of N Fertility and Increase Fertilizer Efficiency in Wetland Rice Soils. *Proceeding of Symposium on Paddy Soil*. 1981. Institute of Soil Science, Academia Sinica. Science Press. Heidelberg. p. 175.

Kossmann W., Poenitz U., Habermehl S., Hoerz T., Kraemer P., Klingler B., Kellner C., Wittur T., Klopotek F.v., Krieg A., and Euler H. 1997. *Biogas Digest Vol. 1. Biogas Basics*. GTZ Project Information and Advisory Service on Appropriate Technology (ISAT). Eschborn, Germany. 45 pages.

Kumar P., Kumar S., and Joshi L. 2014. *Socioeconomic and Environmental Implications of Agricultural Residue Burning: A Case Study of Punjab, India*. Springer New Delhi. p. 25.

Lal R. interviewing in Judith D. Schwartz. *Soil as Carbon Storehouse: New Weapon in Climate Fight?* *Business. Innovat. Climate Sci. Tech.* 04 Mar 2014.

Lampang Cancer Hospital. 2012. *The Fact about Lung Cancer (Thai)*.  
[http://lampangcancerhospital.blogspot.com/2012/09/blog-post\\_23.html](http://lampangcancerhospital.blogspot.com/2012/09/blog-post_23.html)

Land Classification Division (LCD), Thailand and FAO Project Staff. 1973. *Soil Interpretation Handbook for Thailand*. Department of Land Development. Ministry of Agriculture and Cooperatives. Bangkok. 135 pp. in  
Intrawech A. and Imsompooch K. 2011. *Comparison of Soil Chemical Properties in Tung Kula Ronghai Areas*. Department of Land Development. Ministry of Agriculture and Cooperatives. Bangkok. 88 pages (Thai).

Land Development Department (LDD). 2011. *Strategies of LDD in the 11th National Plan for Economic and Social development (2012-2016)-Draft*. Ministry of Agriculture and Corporate. Bangkok. 62 pages (Thai).

Landolt, E. and Kandeler R. 1987. *Biosystematic Investigations in the Family of Duckweeds (Lemnaceae)*. Veroff. Geobot. Inst. ETH. Zurich. vol. 2. pp 42-43. in  
Cross J. 2012. *Duckweed nutritional composition*. [www.mobot.org](http://www.mobot.org)

Landschoot P. and Mcnitt A. 2015. *Using Spent Mushroom Substrate (Mushroom Soil) as a Soil Amendment to Improve Turf*. Penn. State College of Agri. Science. [plantscience.psu.edu](http://plantscience.psu.edu).

Lardmahalab N. *Comparison of Six Media Cultures on Yields of Straw Mushroom*. 2010. Faculty of Agriculture. Department of Horticulture. Kasetsart University. Bangkok. 42 pages.

Launio C.C., Asis Jr. C.A., Manalili R.G., and Javier. E.F. 2013. *Economic Analysis of Rice Straw Management Alternative and Understanding Farmers' choices*. WorldFish (ICLARM)-Economy and Environment Program for Southeast Asia (EEPSEA). Laguna, Philippines. p. 8.

Leng R.A. 1999. DUCKWEED: A tiny aquatic plant with enormous potential for agriculture and environment. FAO. Rome.

Leu A. Organics and Soil Carbon: Increasing soil carbon, crop productivity and farm profitability. 'Managing the Carbon Cycle' Katanning Workshop. 21-22 March 2007. [www.amazingcarbon.com](http://www.amazingcarbon.com).

Linquist B. and Sengxua P. 2005. Nutrient Management for Lowland Rice Field in Lao PDR. Research Institute for Agriculture and Forestry. Ministry of Agriculture and Forestry. Lao PDR. 100 pages (Laos). in Duangwongsa I. 2010. Rice straw Management for Conserving N, P, and K in Paddy Soil, Laos PDR. Graduate Seminar. Faculty of Agriculture, Ubolrajathani University. Ubolrajathani. Thailand. 7 pages.

Liu C.C., Tseng P. Y., and Chen C.Y. The Application of FORMOSAT-2-high-temporal-and-high-spatial resolution imagery for Monitoring Open Straw Burning and Carbon Emission Detection. Nat. Hazards Earth Syst. Sci. 2013. 13. 575-582.

Liu Z., Xu A., Zhao T. Energy from Combustion of Rice Straw: Status and Challenges to China. Energy. Power. Eng. 2011. 3. 325-331.

Lory J., Davis G., Miller R., Steen D., Li B., and Fulhage C. 2007. Calculating Plant-Available Nitrogen and Residual Nitrogen Fertilizer Value in Manure. Uni. Missouri: Extension.

Luangta S. Chittamart N., Tawornpruek S. Agricultural Potential Evaluation of Rice Base Thai Vertisol. 4th National Soil and Fertilizer Conference "Nature of Soil and Fact of Fertilizer for Sustainable Agriculture"(Thai). Prince of Songkla University. 2-4 July 2015. Hadyai. Thailand.

Manzoni S. and Porporato A. Soil carbon and nitrogen mineralization: Theory and models across scales. Soil Biology & Biochemistry. 2009.41. 1355-1379.

Marchaim U. 1992. Chapter nine: Output and its use II. in Biogas Process for Sustainable Development. FAO. Rome.

Masse D.I., Masse L., Calveau S., Benchaar C. and Thomas O. 2008. Methane Emissions from Manure Storage. Trans. ASABE. 51(5). 1775-1781.

Matsueda H. Inoue H.Y., Ishii M., and Tsutsumi Y. Large Injection of Carbon Monoxide into The upper Troposphere due to Intense Biomass Burning in 1997. J. Geophys. Res. 1999. 104. 26867-26879.

McGee M.V. 2010. Aquaculture of Tilapia and Pangasius; A Comparative Assessment Caribe Fisheries Inc. Lajas, PR.

Men, X.B. Ogle, B., & Preston, T.R., 1995. Use of Duckweed (*Lemna* spp) as Replacement for Soybean Meal in A Basal Diet of Broken Rice for Fattening Ducks. In Livestock Research for Rural Development 7:5-8.

Ministry of Agriculture and Cooperatives (MOAC) Thailand. cited in July 2015. Utilization of Organic Fertilizers in Rice Field. Technology and Innovation for rice production (Thai). [http://www.moac.go.th/ewt\\_news.php?nid=438&filename=index](http://www.moac.go.th/ewt_news.php?nid=438&filename=index)

Ministry of Science and Technology (MOST). 2011. Workshop handbook: Biogas Production for Household. Chiang Rai. 26 pages (Thai).

Mongomery L.F.R. and Bochmann G. 2014. Pretreatment of feedstock for enhanced biogas production. IEA Bioenergy. 24 pages.

Morakarn P., Chittamart N., Tawornpruek S. Fertility Capability of Representative Upland Vertisols in Thailand. 4th National Soil and Fertilizer Conference "Nature of Soil and Fact of Fertilizer for Sustainable Agriculture (Thai). Prince of Songkla University. 2-4 July 2015. Hadyai. Thailand.

Muller M.S. and Bauer C.F. 1996. Oxygen Consumption of Tilapia and Preliminary Mass Flows through a Prototype Closed Aquaculture System. NASA Biomedical Operations and Research Office John F. Kennedy Space Center. Fl. 19 pages.

Multiple Crop Center (MCC). cited in September 2015. Soil Fertility in Rice Farm (Thai). Faculty of Agriculture, Chiang Mai University. Chiang Mai. Thailand  
[http://www.mcc.cmu.ac.th/agsust/lowland\\_SA/soilfertsoille\\_lowland.htm](http://www.mcc.cmu.ac.th/agsust/lowland_SA/soilfertsoille_lowland.htm)

Nagayets O. 2005. Small Farms: Current Status and Key Trends. Information Brief. The Future of Small Farms Research Workshop. Kent. UK. 14 pages.

Naskeo Environment. 2009. Biogas Compositon. [www.biogas-renewable-energy.info](http://www.biogas-renewable-energy.info).

Nath K., Sahai K., and Kehar N. D. 1969 Effect of water washing, lime treatment and lime and calcium carbonate supplementation on the nutritive value of paddy straw. J. Animal Sci. 28. 383-391. in Trach N.X., Mo M., and Dan C.X. Effects of treatment of rice straw with lime and/or urea on its chemical composition, in-vitro gas production and in-sacco degradation characteristics. Livestock Research for Rural Development 13 (4) 2001. Article#35.

National Energy Policy Office (NEPO) Thailand. Promoting of Biogas Production in Animal Farms.. J. Energy Policy. 2000. 47. Jan-March (Thai).  
<http://www.eppo.go.th/vrs/VRS47-07-BioGas.html>

National Environment Research Institute and Danish Institute for Advance Studies. in Ministry of Food, Agriculture, and Fisheries and Ministry of Environment and Energy. 26 April 2001. Action Plan for Reducing Ammonia Volatilization from Agriculture. 17 pages.

National Statistics Office (NSO), Thailand. 2011. Summary of Statistics on Energy consumption of Household in year 2011. NSO service.3 pages (Thai).

Nurit K. 2012. Report on Price Situation of Tilapia and its products in first half year 2012. Department of Fisheries. Ministry of Agriculture and Cooperatives. Bangkok. 6 pages (Thai).

Oan N.T.K. 2012. Integrated Air Quality Management: Asian Case Studies. CRC Press. Boca Raton. FL. p. 334.

Oanh. N. T. K., Bich T.L., Tipayarom D., Manadhar B.R., Prapat P., Simpson C.D., and Liu L.J.S. Characterization of Particulate Matter Emission from Open Burning of Rice Straw. Atmos. Environ. 2011. 45(2). 493–502.

Office of Agricultural Eoomics (OAE) Thailand. 2012. Agricultural Statistics of Thailand 2012. Ministry for Agricultural and Cooperatives. Bangkok. 176 pages (Thai).

Office of Agricultural Economics (OAE) Thailand. 2012. Basic data for Agricultural Economics 2012. Ministry For Agricultural and Cooperatives. Bangkok. pp. 49-52 (Thai).

Office of Agricultural Economics (OAE) Thailand. June 2012. Data on rice farmers' registration in year 2011 (Thai). Ministry of Agriculture and Cooperatives. Thailand.  
<http://www.edoae.doae.go.th/data%20rice%20%2054%20240612%201.pdf>

Office of Agricultural Economics (OAE) Thailand. Report on the Possibility of Exporting Thai Agricultural Products to ASEAN. Workshop "The possibility of exporting Thai Agricultural Products ASEAN ". 16 and 18 Sept. 2013. Bangkok. 15 pages (Thai).

Office of Agricultural Economics (OAE) Thailand. cited in May 2015. Cultivation of Mushroom straw in the basket: Instruction Video-clip (Thai).  
<http://www2.oae.go.th/infozone3/index.php/temashroom-sm>

Office of Air Quality Standard USA., Office of Air and Radiation USA, and US-EPA. 1995. Chapter 13.3. Fugitive Dust. in AP 42, 5th Ed. Compilation of Air Pollutant Emission Factors,

Volume 1: Stationary Point and Area Sources. . Office of Air Quality Standard., Office of Air and Radiation, US-EPA. Research Triangle Park. NC. pp. 13.2-1-13.2-2.

Office of Natural Resources and Environmental Policy and Planning (ONREPP) Thailand. 2010. Thailand's Second National Communication under the United Nations Framework Convention on Climate Change. Ministry of Natural Resources and Environment. Bangkok. p. 43.

Oh Y.K., Lee W.M., Choi C.W., Kim K.H., Hong S.K., Lee S.C., Seol Y.J., Kwak W.S, and Choi N.J. Effects of Spent Mushroom Substrates Supplementation on Rumen Fermentation and Blood Metabolites in Hanwoo Steers. *Asian Australas. J. Anim. Sci.* 2010. 23 (12). 1608-1613.

Ongprasert S. 2004. Nutrient Management for Rice field. Learning Documents. Applied Soil Science. Department of Soil, Water, and Environment, Faculty of Agricultural Products. Maejo University (Thai).

Onwongsa I. 2012. who gains from raising up the price of LPG. Foundation for Consumer, Thailand. 17 July 2012 (Thai).  
[http://www.consumerthai.org/main/index.php?option=com\\_content&view=article&id=2396:2012-07-17-03-21-06&catid=216:2012-05-28-14-23-56](http://www.consumerthai.org/main/index.php?option=com_content&view=article&id=2396:2012-07-17-03-21-06&catid=216:2012-05-28-14-23-56)

Owen E., Klopfenstein T., and Urio N. A. 1984. Treatment with Other Chemicals. in *Straw and Other By-products as Feed*. Amsterdam Sundstøl F. and Owen E. C. Eds. Elsevier. pp 248-275. in Trach N.X., Mo M., and Dan C.X. Effects of treatment of rice straw with lime and/or urea on its chemical composition, in-vitro gas production and in-sacco degradation characteristics. *Livestock Research for Rural Development* 13 (4) 2001. Article#35.

Paipard n., Supannatas S., and Suttiaprapa T. Effects of pesticide use on farmer's health and the environment in Rong Kham district, Kalasin province. *Khon Kaen Agr. J.* 2014. 42 (3). 301-310.

Panpradist B. and Ruenruengjai A. and Biogas digester for Household. *Natural Agriculture.* 2006. 9 (6). 24-28 (Thai).

Paosingha T. Pengdhammakitti P. Assesment of CO2 emission and Carbon absorption in paddy of chemical Farm and Organic Farm with Water irrigation. Climate Thailand Conference. Climate Change and Green Economy: Pathway to Response. The 2nd National Carbon Neutral Conference. Bangkok. 18-19 August 2011.

Phan C.W. and Sabaratnam V. Potential uses of Spent Mushroom Substrate and its Associated Lignocellulosic Enzymes. *Appl Microbiol. Biotechnol.* 2012. 96. 863– 873.

Phopinit S. and Limtrakul K. 1999. Change of The Properties of Forest Soils. *Silvicultural Research Report* 1999. 80-102.

Phyper J. 2012. How to Construct a Straw Bale House.  
<http://www.solarhaven.org/NewStrawbale.htm>

Pibumrung P., Gajasen N., and Popan A. Profiles of Carbon Stocks in Forest, Reforestation and Agricultural Land, Northern Thailand. *J. Forestry Res.* 2008. 19(1). 11 -18.

Polpibool T., Chaisawat I., and Roongpisuttipong A. Disaster in the Winter of Particulate Matter (PM<sub>2.5</sub>). *EAU Heritage J. Sci. Technol.* 2014. 8 (1). 40-46.

Ponnamperuma F.N. 1984. Straw as a source of nutrients for wetland rice. *Organic Matter and Rice*. International Rice Research Institute. Los Banos Philippines page 117-136. in Promnat P. Rice Cultivation without Stubble Burning (Thai). 23 Feb 2006. Department of Agricultural extension. Bangkok.  
<http://www.geocities.ws/pisitrice/a4.htm>

Popma T, Masser M. 1999. Tilapia life history and biology. Southern Regional Aquaculture Center. Publication No. 283: 1-4.

Pottmaier D., Costa M. Farrow T., Oliviera A.A.M., Alarcons O., and Snape C. Comparison of Rice Husk and Wheat Straw: From Slow and Fast Pyrolysis to Char Combustion. *Energy Fuels*, 2013, 27 (11). 7115–7125.

Prapamongkol T., Kerdnoi T., Chantara S., Danpaiboon A., Panichakool P., Rankakulnuwat S., Chaisawat S., and Kiatwatchareon S. Effect of Air Pollution on Health Problems. A study of Air Pollution and its effect on public health in upper North of Thailand. Oral Presentation. National Council of Research Thailand (NCRT). 7 September 2010.  
[http://www1.nrct.go.th/downloads/pc/seminar/file\\_solve\\_global\\_warming/3.presentation3.pdf](http://www1.nrct.go.th/downloads/pc/seminar/file_solve_global_warming/3.presentation3.pdf)

Premprasit S. Carbon dioxide Emission from Rice Straw Burning in Utaradit, Phisanuloke, and Pichit. Oral Presentation. Seminar Presentation for Research Project Supported by NRCT. 3 Feb 2012. National Research Council of Thailand. Bangkok.  
[http://www1.nrct.go.th/downloads/pc/seminar/file\\_solve\\_global\\_warming/2.presentation2.pdf](http://www1.nrct.go.th/downloads/pc/seminar/file_solve_global_warming/2.presentation2.pdf)

Premprasit S., Bunyanupap J., Premprasit R., Poolput T., Ponsathornpreuk S., Na Wichean C., and Kraiwijit P. 2011. Total Carbon Budget in Paddy Rice of Lower Northern Region, Thailand (2011). Oral Presentation Seminar Presentation for Research Project supported by NRCT. 3 Feb 2012. National Research Council of Thailand. Bangkok.  
[http://www1.nrct.go.th/downloads/pc/seminar/file\\_solve\\_global\\_warming/2.presentation2.pdf](http://www1.nrct.go.th/downloads/pc/seminar/file_solve_global_warming/2.presentation2.pdf)

Promnat P. Rice Cultivation without Stubble Burning (Thai). 23 Feb 2006. Department of Agricultural extension. Bangkok.  
<http://www.geocities.ws/pisitrice/a4.htm>

Rakocy JE, Masser M, Losordo TM. 2006. Recirculation aquaculture tank production systems: aquaponics-integrating fish and plant culture. Southern Regional Aquaculture Center; Publication No. 454. 1-16.

Rambo P.W. cited in August 2015. Soil Fertility and Plant Nutrition. Lecture Presentation (Thai). Khon Khan University . Khon Khan. Thailand.  
[http://ag.kku.ac.th/academic/new/file/pattama/132351%20Lec%207%20%20\(Nitrogen\).pdf](http://ag.kku.ac.th/academic/new/file/pattama/132351%20Lec%207%20%20(Nitrogen).pdf)

Rehm G., Schmitt M., Lamb J, Randall G., and Busman L. 2002. Understanding Phosphorus Fertilizers. University of Minnesota: extension.

Reid J.S., Koppman R., Eck T.E., Eleuterio D.P. A review of biomass burning emissions part II: intensive physical properties of biomass burning particles. *Atmos. Chem. Phys.* 2005. 5. 799–825.

Reid J., Hyer E.J., Johnson R.S., Holbern B.N., Yokelson R.J., Zhang J., Campbell J.R., Christopher S.A., Girolamo L.D., Giglio L., Holz R.E., Kearny C., Miettinen J., Reid E.A., Turk J., Wang J., Xian Peng., Zhao G., Balasubramanian R., Chew B.N., Janjai S., Lagrosas N., Lestari P., Lin N., Mahmud M., Nguyen A.X., Norris B., Oanh N.T.K., Oo M., Salinas S.V., Welton E.J., and Liew S.C. Observing and Understanding the Southeast Asian Aerosol System by Remote Sensing: An Initial Review and Analysis for The Seven Southeast Asian Studies (7SEAS) program. *Atmospheric Res.* 2013, 122..403–468

Rennan G. O. Macedo S.M, Korn M.G.A., Pimentel M.F., Bruns R.E., and Ferreira S.L.C. Mineral Composition of Wheat Flour Consumed in Brazilian Cities. *J. Braz. Chem. Soc.* 2008.19 (5). 935-942.

Rodriguez L. and Preston T.R. 1996. Use of Effluent from Low-cost Plastic Biodigesters as Fertilizer for Duckweed Ponds. *Livestock Res. Rural Dev.* 8 (2). Article#19.

Rubasinghege G., Spak S.N., Stanier C.O., Carmichael G.R., and Grassian V.H. Abiotic Mechanism for the Formation of Atmospheric Nitrous Oxide from Ammonium Nitrate. *Environ. Sci. Technol.* 2011. 45 (7). 2691–2697.

Russell C.W. and Johnson W.J. 1996. Kentucky Blue Grass Post-Harvest Straw-Base Particle Board Phase 1 Report to Washington State Department of Ecology. Department of Crop and Soil Science. Washington State University. Pullman. WA. 88 pages.

Saenjan P., Keophila M., Thammasome N., Lawongsa P., Tulaphitak D., and Dejphimon K. Rice Straw Influencing Reductive Condition in Paddy Soil and Methane Emission (Rice Planted Pot Experiment). *Khon Kaen Agr. J.* 2014. 2 (1).235-240.

Sanchis E., Ferrer M., Calvet S., Coscolla C., Yusa V., and Cambra-Lopez a M. Gaseous and particulate emission profiles during controlled rice straw burning. *Atmos. Environ.* 2014. 98. 25-31.

Santos V.B. , Marin T.R., and Freitas R.T.F. Body Composition of Nile Tilapias (*Oreochromis niloticus*) in Different Length Classes. *Ci. Anim. Bras., Goiânia.* 2012. 13(4). 396-405.

Sauvant D., Milgan J.V., Favordin P., Friggens N. 2010. Modeling Nutrient Digestion and Utilization in Farm Animals. Wageningen Academic Pub. Wageningen. The Natherlands. p. 415.

Selfnutrientdata. cited in May 2015. Tilapia cook and dried heat. Nutrition fact. <http://nutritiondata.self.com/facts/finfish-and-shellfish-products/9244/2>

Seinfeld J. and Pandis S. 1998. Atmospheric Chemistry and Physics: From Air Pollution to Climate Change. 2nd ed. John Wiley & Sons, Inc. Hoboken NJ. p. 97.

Shen G., Wang W., Yang Y., Ding J., Xue M., Min Y., Zhu C., Shen H., Li W., Wang B., Wang R., Wang X., Tao S. and Russell A.G., Emissions of PAHs From indoor crop Residue burning in A Typical Rural Stove: Emission Factors, Size Distributions, and Gas-Particle Partitioning, *Environ. Sci. Technol.* 2011. 45. 1206–1212. in  
Tripathi S., Singh R.N., and Sharma S. Emissions from Crop/Biomass Residue Burning Risk to Atmospheric Quality. *Int. Research J. Earth Sci.* 2013. 1(1). 24-30.

Shiga H. 1997. The Decomposition of Fresh and Composted Organic Materials in Soil. FFTC Database. Food& Fertilizer Technology Center. Taipei. 14 pages.

Silalertruksa T. and Gheewala S.H. A Comparative LCA of Rice Straw Utilization for Fuels and Fertilizer in Thailand. *Biores. Technol.* 2013.150. 412-9.

Sillapapiromsuk S., Chantara S., Tengjaroenkul U. , Prasitwattanaseree S., and Prapamontol T. Determination of PM<sub>10</sub> and its Composition Emitted from Biomass Burning in the Chamber for Estimation of Open Burning Emissions. *Chemosphere.* 2013. 93 (9). 1912-1919.

Simachaya V. Air pollution from Haze episode in North of Thailand: Problems and Solutions. Seminar "Global warming:- The Pollution from Haze Episode" Seminar of Senate committee on Natural resources and Environment. 11 Feb. 2011. Chiang Mai, Thailand. 11 pages (Thai).

Singh N., Mittal S.K., Agarwal R., Awasthi A. and Gupta P.K., Impact of Rice Crop Residue Burning on levels of SPM, SO<sub>2</sub> and NO<sub>2</sub> in The Ambient Air of Patiala (India), *Intern. J. Environ. Anal. Chem.* 2010. 90 (10). 829–843. in  
Tripathi S., Singh R.N., and Sharma S. Emissions from Crop/Biomass Residue Burning Risk to Atmospheric Quality. *Int. Research J. Earth Sci.* 2013. 1(1). 24-30.

Singh R. P., Dhaliwal H. S., Sidhu H. S., Manpreet-Singh Y. S., and Blackwell J. 2008. Economic assessment of the Happy Seeder for rice-wheat systems in Punjab, India. Conference Paper, AARES 52nd Annual conference, Canberra, ACT. Australia. in  
Kumar P., Kumar Surender., and Joshi L. Socioeconomic and Environmental Implications of Agricultural Residue Burning: A Case Study in Panjab, India. Springer. New Delhi. page. 25.

Singh Y., Singh B., Ladha J.K., Khind C.S., Kehra T.S., and Bueno C.S. Effects of Residue Decomposition on Productivity and Soil Fertility in the Rice-Wheat Rotation. *Soil. Sci. Soc. Am. J.* 2004. 68. 854-864 in  
Fageria N.K. 2014. Nitrogen Management in Crop Production. CRC Press. Boca Raton. FL. page 197.

Skillicorn P., Spira W., and Journey W. 1993. Duckweed aquaculture : A New Aquatic Farming System for Developing Countries. The World Bank . Washington. DC. 92 pages

Slanina, S. 2013. Aerosols. The Encyclopedia of Earth. [www.eoearth.org](http://www.eoearth.org).



- Srichana P. and Kwalamtharn P. 2012. THE Reduction Wasted Materials in Concrete Brick Production Process Study: Maha-Anajak Company Limited. Special Project. Major Industrial Management. Faculty of Technology. Udonthani Rajabhat University. UdonThani. Thailand. 45 pages (Thai).
- Stamet P. and Chilton J.S .1983. The Mushroom Cultivator. Agarikon Press. Olympia. Washington. pp.110 and 214.
- Steffen R., Szolar, O. and Braun, R. 1998. Feedstocks for Anaerobic Digestion. The European Anaerobic Digestion Network. p. 17.
- Stewart L. Mineral Supplements for Beef Cattle. UGA Cooperative Extension Bulletin. 895. March 2013. 1-16.
- Streets, D.G., Yarber K.F. ,Woo J.H., and Carmichael G.R. Biomass Burning in Asia. Annual and Seasonal Estimates and Atmospheric Emissions. Glob. Biogeochem. Cycles. 2003. 17(4).1099.
- Summer M.D., Blunk S.L., and Jenkins B.M. 2003. How Straw Decomposes: Implications for Straw Bale Construction. Ecobuildingnetwork. USA. 6 pages.
- Suranaree University of Technology (SUT). 2010. Urea Treatment for Rice Straw. Document for training. Community knowledge-base service. SUT. Nakorn Rajaseema. Thailand. 4 pages (Thai).
- Schwartz J. D. Soil as Carbon Storehouse: New Weapon in Climate Fight?. Business&Innovat. Climate Sci. Technol. Sustainability. Water. North America. 04 MAR 2014.
- Tai-Yi Y. Characterization of ambient air quality during a rice straw burning episode. J Environ Monit. 2012. 14(3). 817-29.
- Thananont T. 2014. Biomass Power Plant: Problems and Solutions. Sukothai Thammathirat Open University (Thai).  
[http://www.stou.ac.th/study/sumrit/3-57\(500\)/page1-3-57\(500\).html](http://www.stou.ac.th/study/sumrit/3-57(500)/page1-3-57(500).html)
- Towprayoon S. 2006. Methodology for Measurement of GHG from Rice Field. Oral Presentation. APN Training Workshop. JGSEE. 1-3 May 2006. Bangkok.
- Towprayoon. 2007. Greenhouse Gas (GHG) and Aerosol Emissions under Different Vegetation Land-use in the Mekong River Basin Sub-region. Asia-Pacific Network for Global Change Research. 220 pages.
- Towprayoon S., Rusmana I., Yagi K. 2013. Strategic Rice Cultivation for Sustainable Low Carbon Society Development in South East Asia. FINAL REPORT for Asia-Pacific Network (APN) PROJECT. Asia-Pacific Network for Global Change Research. 476 pages.
- Thailand Research Fund. 2007. Policy Research on Renewable Energy Promotion and Energy Efficiency Improvement in Thailand Project-Final Report in  
 Wannapreera J., Worasuwanarak, and Pipatmanomai S. Product Yields and Characteristics of Rice Husk, Rice Straw, and Corncob during fast Pyrolysis in a Drop-tube/fixed bed Reactor. Sonklanakarin J. Sci. Technol. 2008. 30 (3). 393-404.
- Thammasome N, Kaophila M., Tulaphituk D., Dachphimon K., Songsri P., and Saenjan P. 2013. Rice Straw Rates Influencing Rice Yields and Greenhouse Gases. Khon Kaen Agr. J. 41 (2).33-38.
- The Joint Graduate School of Energy and Environment (JGSEE). 2012. A complete Project Report: Preparation of Database of GHG Emission from Agriculture Sector. OAE. Thailand. 452 pages (Thai).
- Tipayarom A. PM<sub>10</sub> Levels and Hotspots in Western Thailand in Agro-Residue Burning Season. Slipakorn U. Sci.Technol. J. 2012. 6(2) 30-36.
- Tipayarom D. and Oanh N.T. K. Effects from Open Rice Straw Burning Emission on Air Quality in the Bangkok Metropolitan Region. Sci. Asia. 2007. 33. 339-345.

Trach N.X., Mo M., and Dan C.X. 2001. Effects of treatment of rice straw with lime and/or urea on its chemical composition, in-vitro gas production and in-sacco degradation characteristics. *Livestock Research for Rural Development*. 2001. 13 (4). Article#35.

Tripathi S., Singh R.N., and Sharma S. Emissions from Crop/Biomass Residue Burning Risk to Atmospheric Quality. *Int. Research J. Earth Sci.* 2013. 1(1). 24-30.

Thiribhuvanamala G., Krishnamoorthy S., Manoranjittham K., Praksasm V., and Krishnan S. Improved Techniques to Enhance the Yield of Paddy Straw Mushroom (*Volvariella volvacea*) for Commercial Cultivation. *Afri. J. Biotechnol.* 2012. 11(64). 12740-12748.

Truc, N. 2011. Comparative Assessment of Using Rice Straw for Rapid Composting and Straw Mushroom Production in Mitigating Greenhouse Gas Emissions in Mekong Delta, Vietnam, and Central Luzon, Philippines. Unpubish Ph.D. Thesis. University of the Philippines. Los Banos. Phillipines.305 pages.

Truc N.T.T., Sumalde Z.M., and Wassmann R. 2013. Alternative Uses of Rice Straw for Mitigating Methane Emission in Vietnam and the Phillipines: II: Cost-Benefit Assessment of Shifting to Rapid Composting and Straw Mushroom Production. *International Conference on Environmental Pollution, Restoration and Management*. p. 41.

Usack J.G.,Wiratni W., and Angenet L.T. Improved Design of Anaerobic Digesters for Household Biogas Production in Indonesia: One Cow, One Digester, and One Hour of Cooking per Day. *Scientific World J.* 2014. Article No. 318054. 4 pages.

UNESCO. 1982. Dispersion and Self Purification of Pollutants in Surface Water System. Whitehead P.C. and Lack T. eds. *International Hydrological Programme*. UNESCO. Paris. p. 35.

United States Environmental Protection Agency (US-EPA).2000. Air Quality Criteria for Carbon Monoxide. US-EPA. Research Triangle Park. NC. pp. 3.3-3.9.

United States Environmental Protection Agency (US-EPA). 2005. Emission Facts.

United States Environmental Protection Agency (US-EPA).US-EPA. data. from [www.epa.gov](http://www.epa.gov).

Utistham, T., Soontornrangsarn, W. and Piyakuldumrong P. Energy potential from residual biomasses in Thailand. *Proceedings of the 3rd Energy Technology Network of Thailand (ENETT)*, Bangkok, Thailand, May 23-25 2007. 1-6. in

Wannapeera J., Wongrasuwannarak N., and Pipatmanomai S. Production Yields and Characteristics of Rice Husk, Rice Straw and Corncob during Fast Pyrolysis in a Drop-Tube/Fixed-Bed Reactor. *Songklanakarin J. Sci. Technol.* 2008. 30 (3). 393-404.

Verapat P. Utilization of fertilizers in the Rice Field. 1977. 3rd Encyclopedia for youth. Project of Encyclopedia for youth. Bangkok.

Vert M., Doi Y., Hellwich K.H., Hess M., Hodge P., Kubisa P., Rinaudo M., Schué F. Terminology for biorelated polymers and applications (IUPAC Recommendations 2012). *Pure and Applied Chemistry*. 2012. 84 (2). 337-410.

Vibool S. and Taoprayoon S. Estimation of methane and nitrous oxide emissions from rice field with rice straw management in Cambodia. *Environ. Monitoring. Assessment*. 2010. 161 (1). 301-313.

Vidal J. India's rice Revolution. *The Guardian*. Feb 16, 2013.

Violante A. and Huang P.M. Influence of Oxidation Treatment on Surface Properties and Reactivities of Short-range Ordered Precipitates of Aluminium. *Soil Sci. Society Am. J.* 1989. 53. 1402-1407. in Ding W.Y.X, Xue S., Li S., Liao X., and Wang R. Effects of Organic-Matter Application on Phosphorus Adsorption of Three Soil Parent Materials. *J. Soil Sci. Plant Nutrit.* 2013. 13 (4). 1003-1017.

Wanchai K. 2013. The Application of Indigenous Microorganisms Immobilized on Different Materials for Soil Quality Improvement of Flooded Rice Fields: Case Study in Ampor Bangban, Pranakorn Si Ayutthaya. Rajabhat Sriyuthaya University. Thailand. 82 pages (Thai).

Wang C. and Prinn R.G. 1998. Impact of emissions, chemistry, and climate on atmospheric carbon monoxide : 100-year predictions from a global chemistry-climate model. MIT Joint Program on the Science and Policy of Global Change Report. 11 pages.

Wannapeera J., Wongrasuwannarak N., and Pipatmanomai S. Production Yields and Characteristics of Rice Husk, Rice Straw and Corncob during Fast Pyrolysis in a Drop-Tube/Fixed-Bed Reactor. Songklanakarin J. Sci. Technol. 2008. 30 (3). 393-404.

Weiss .W.P. 2007. Energetics for the Practicing Nutritionist. Proc. 2007 Minnesota Nutr. Conf., Minneapolis, MN, pp 9-18.

Wilke A.C. 2013. Biodigesters for Developing Countries. Biogas, A Renewable Biofuel. University of Florida. biogas.ifas.ufl.edu.

WHO-UNEP-WMO. 1999. Health Guideline for Vegetation Fire Events. Schwela D.H., Goldammer J.G., Morawska L.H., and Simpson O. eds. WHO. Geneva. 491 pages.

Yuan Q., Pump J., and Conrad R. Partition of CH<sub>4</sub> and CO<sub>2</sub> Production Originating from Rice Straw, Soil, and Root Organic Carbon in Rice Microcosms. PLOS ONE. 2012. 7 (11). 1-9.

Watanabe A. Yoshida M., and Kimura M. Contribution of Rice Straw Carbon to CH<sub>4</sub> Emission from Rice Paddies Using <sup>13</sup>C-Enriched Rice Straw. J. Geophysical Res. 1998. 103 (D7). 8237-8242.

Zaman M S, Owen E and Pike D J 1994 The Calculation Method Used for Optimizing Conditions of Treatment of Barley Straw with Calcium Hydroxide and Urea, Moisture, Treatment Time and Temperature on *in-vitro* Digestibility. Anim. Feed Sci. Technol. 45. 271-282. in Trach N.X., Mo M., and Dan C.X. Effects of treatment of rice straw with lime and/or urea on its chemical composition, in-vitro gas production and in-sacco degradation characteristics. Livestock Research for Rural Development 13 (4) 2001. Article#35.

Zarfar S. Biogas from Agricultural Wastes. Bioenergy Consult. 27 July 2015.

Zhang C.K., Gong F., Li D.S. A Note on The Utilisation of Spent Mushroom Composts in Animal Feeds. Biores. Technol. 1995. 52.89– 91. in

Phan C.W. and Sabaratnam V. Potential Uses of Spent Mushroom Substrate and its Associated lignocellulosic enzymes. Appl. Microbiol. Biotechnol. 2012. 96. 863– 873.

Zheng Chang Co., Ltd. cited in September 2015. Particle board from Rice straw and Wood Residue. Alternative Energy and Environmental Protection Project.

Zhuang, Q., Melillo J.M., Kicklighter D.W., Prinn R.G., McGuire A.D., Steudler P.A., Felzer B.S., and Hu. S. Methane Fluxes Between Terrestrial Ecosystem and The Atmosphere at Northern High Latitudes During The Past Century: A Retrospective Analysis with A Process-Based Biogeochemistry Model. Global Biogeochem. Cycl. 2004. 18 (3). GB3010, doi:10.1029/2004GB002239.

Zimmo O. 2003. Nitrogen Transformations and Removal Mechanisms in Algal and Duckweed Waste Stabilisation Ponds. PhD. Dissertation. Wageningen University and International Institute for Infrastructural, Hydraulic and Environmental Engineering. Delft. The Netherlands.

## Annex

### Data from references for MFA Calculation in STAN

The definition of abbreviations used for data sources in this Annex.

a1= primary data from chemical analysis in the laboratory

a2 = secondary data from the experiment or statistics

a3 = secondary data from reports or reviews

b1= data with country or conditions specific to Thailand

b2 = data with specific or similar to type of plant, animal, region, climate, method

b3 = universal data, default data, or estimated data

b4 = emission data of N<sub>2</sub>O from volatile N loss to the atmosphere, deposition data of N and PM

where

a1b1 = 10% uncertainty

a2b1-a3b2 = 20% uncertainty

a3b3 = 30% uncertainty

a3b4 = 100%

**Table A1. Data for MFA calculation in Status Quo**

Processes	Parameters or constant values					
	Flows	Data	Abbreviations	Values	Units/ y.ha	Sources
Straw production	st1	paddy grain/ straw	B	1	kg/kg	Devandra (1985) <sup>a2b2</sup>
		Carbon in straw	C <sub>st</sub>	0.41	kg/kg	Jenkins <i>et al</i> (2003) <sup>a2b2</sup>
		Oxygen in straw	O <sub>st</sub>	0.44	kg/kg	
		Hydrogen in straw	H <sub>st</sub>	0.0042	kg/kg	
		N in straw	N <sub>st</sub>	0.0070	kg/kg	
		Phosphorus in straw	P <sub>st</sub>	0.0017	kg/kg	
	O <sub>2p</sub>	O <sub>2</sub> / produced straw	$M_{O2/St1}$	0.93	kg/kg	Calculated data
	H <sub>2Op</sub>	H <sub>2</sub> O/ produced straw	$M_{H2O/St1}$	0.35	kg/kg	Calculated data
	N <sub>fu</sub>	N in N flow fertilizer to produce straw	N <sub>Nfu</sub>	1	kg/kg	defined data
P <sub>fu</sub>	P in P flow from fertilizer for straw	P <sub>Pfu</sub>	1	kg/kg	defined data	
Straw Distribution	st2	Straw for livestock /produced straw	$T_{st2/st1}$	0.15	kg/kg	DEDE (2003) <sup>a2b1</sup> and Choenchoklin <i>et al</i> (2010) <sup>a2b1</sup> , comparing to the data from interviewing
	st3	Straw for burning /produced straw	$T_{st3/st1}$	0.48	kg/kg	
	tst	Trade straw /produced straw	$T_{tst/st1}$	0.014	kg/kg	
	sts	Straw to soil /produced straw	$T_{sts/st1}$	0.35	kg/kg	
RSOB	stcb	Combustible part /straw for burning	$T_{stcb/st3}$	0.80	kg/kg	Kanokkanjana and Gariviat (2013) <sup>21b1</sup> and IPCC, 2006
		C in Combustible part /total C in straw	$T_{Cstcb/Cst3}$	0.92	kg/kg	Kanokkanjana and Gariviat (2013) <sup>a2b1</sup>
		N in combustible part/total N in straw	$T_{Nstcb/Nst3}$	0.90	kg/kg	Singh <i>et al</i> (2008) <sup>a2b2</sup>
		P in combustible P/total N in straw	$T_{Pstcb/Pst3}$	0.25	kg/kg	Singh <i>et al</i> (2008) <sup>a2b2</sup>
	O <sub>2b</sub>	O <sub>2</sub> for RSOB/ combustible part in straw	$M_{o2b/Stcb}$	0.65	kg/kg	Base on Oanh <i>et al</i> (2011) <sup>a2b1</sup>
	CO <sub>2b</sub>	CO <sub>2</sub> emitted/ combustible part in straw	$M_{CO2b/Stcb}$	1.50	kg/kg	Gadde <i>et al</i> (2009) <sup>a2b1</sup>
	CO	CO emitted/ combustible part in straw	$M_{CO/Stcb}$	0.093	kg/kg	Oanh <i>et al</i> (2011) <sup>a2b1</sup>
	PM	PM emitted/ combustible part in straw	$M_{PM/Stcb}$	0.0091	kg/kg	
	CH <sub>4</sub>	CH <sub>4</sub> emitted/ combusible part in straw	$M_{CH4/Stcb}$	0.0096	kg/kg	Christian <i>et al</i> (2003) <sup>a2b2</sup>
	NO <sub>2</sub>	NO <sub>2</sub> emitted/ straw for burning	$M_{NO2/St3}$	0.0020	kg/kg	IPCC (2006) <sup>a3b2</sup>

**Table A1 Data for MFA calculation in Status Quo (continued)**

Process	Parameters or constant value					
	Flows	Data	Abbreviations	Values	Units/ y.ha	Sources
Livestock Digestion	LSwg	C in livestock tissue	C <sub>lswg</sub>	0.58	kg/kg	IPCC (2000) <sup>a3b2</sup> and Stewart (2013) <sup>a3b2</sup>
		N in livestock tissue	N <sub>lswg</sub>	0.17	kg/kg	
		P in livestock tissue	P <sub>lswg</sub>	0.0016	kg/kg	
		C in LS/ straw for livestock	$M_{C_{lswg}/C_{st2}}$	0.081	kg/kg	Calculated data
		Livestock DM	DM <sub>LS</sub>	26	%	de Almeida <i>et al</i> (2006) <sup>a2b2</sup>
	O2ls	O <sub>2</sub> consumed/straw for livestock	$M_{O2ls/St2}$	0.99	kg/kg	Calculated data
	Mls	Manure produced /straw for livestock	$M_{mils/St2}$	0.45	kg/kg	Based on Weiss (2007) <sup>a3b2</sup> and FAO (2001) <sup>a3b2</sup>
	Nals	Supplement N from cost-free plants/ straw for livestock	$M_{Nals/St2}$	0.0080	kg/kg	Calculated data
	LSwg	C in LS tissue / C straw for livestock	$T_{C_{lswg}/C_{st2}}$	0.081	kg/kg	Base on Weiss (2007) <sup>a3b2</sup>
	CH4ls	C in CH <sub>4</sub> from rumen/C straw for livestock	$T_{C_{ch4}/C_{st2}}$	0.07	kg/kg	
CO2ls	C in CO <sub>2</sub> from LS respiration/ C straw for livestock	$T_{CO2/C_{st2}}$	0.45	kg/kg		
Manure Collecting	Nlm	total volatile N loss / N in fresh manure	$T_{Nlm/Mls}$	0.29	kg/kg	Masse <i>et al</i> (2008) <sup>a2b2</sup> , Gunnerson and Stukeley (1986) <sup>a2b1</sup>
	CH4m	Fraction of VS in manure	VS <sub>m</sub>	0.75	kg/kg	Joergensen <i>et al</i> (2009) <sup>a3b2</sup>
		Biodegradability of manure	Bo	0.10	m <sup>3</sup> CH <sub>4</sub> /kgVS	IPCC (2000) <sup>a3b2</sup>
		Density of methane	D <sub>CH<sub>4</sub></sub>	0.75	kgCH <sub>4</sub> /m <sup>3</sup> CH <sub>4</sub>	Joergensen <i>et al</i> (2009) <sup>a3b2</sup>
		Methane conversion factor	MCF	0.02	kg/kg	IPCC (2001) <sup>a3b2</sup>
		manure used/total manure	MF	1	kg/kg	OAE (2011) <sup>a2b1</sup> and interviewing
		Methane emitted/manure	CH <sub>4</sub> /manure	0.0027	kg/kg	calculated data <sup>a3b3</sup>
Chemical Distribution	Fam	P from ammophos/ P plants need from Ammophos to produce straw	$M_{pfa/Pfu}$	5	kg/kg	Rehm <i>et al</i> (2002) <sup>a3b2</sup>
	Fur	N from urea / N plants need from Urea to produce straw	$M_{Fur/Nu}$	3	kg/kg	Ongprasert (2004) <sup>a3b1</sup>

**Table A1 Data for MFA calculation in Status Quo (continued)**

Process	Parameters or constant value					
	Flows	Data	Abbreviations	Values	Units/ y.ha	Sources
Pedosphere and hydrosphere	CH4s	C in CH4 emitted /C straw to soil	$M_{Cch4s/Csts}$	0.059	kg/kg	Thammasom <i>et al</i> (2013) <sup>a2b1</sup>
	CO2	Carbon in CO2emitted/straw left on paddy soil	$M_{Cco2s/Csts}$	0.003	kg/kg	Phaoseeha and Pengdhammakitti (2011) <sup>a2b1</sup>
	Ss	N effectiveness from soil	$M_{NSs/NRs}$	0.6	kg/kg	Lory <i>et al</i> (2007) <sup>a3b3</sup>
		Available P from soil	$M_{Pa/PRs}$	0.6	kg/kg	Rehm <i>et al</i> (2002) <sup>a3b3</sup>
	Nsa	N loss from soil to the atmosphere	$M_{Nsa/NRs}$	0.2	kg/kg	IPCC, 2006 (JGSEE, 2012) <sup>a3b2</sup>
	Rhd	Drain water from paddy field	$V_{wd}$	12500	m <sup>3</sup> /y.ha.	DPC (2011) <sup>a2b1</sup>
		C wash-out/ C released to soil	$M_{CRhd/CRs}$	0.090	kg/kg	DPC (2011) <sup>a2b1</sup>
		N wash-out/ N released to soils	$M_{NRhd/NRs}$	0.089	kg/kg	DPC (2011) <sup>a2b1</sup>
		P wash-out/ P released to soil	$M_{PRhd/PRs}$	0.088	kg/kg	DPC (2011) <sup>a2b1</sup>
	PMd	deposited PM to hydrosphere/ total deposited PM	$T_{PMhd/PMd}$	0.5	kg/kg	IPCC (2006) <sup>a3b4</sup>
	RNA	deposited N to hydrosphere/ total deposited N	$T_{rNt/RNa}$	0.5	kg/kg	Assumed data from IPCC (2006) <sup>a3b4</sup>
Atmosphere	N2Os	N in N <sub>2</sub> O from volatile N/ total loss of volatile N	$T_{NN2Os/Nl}$	0.01	kg/kg	IPCC, 2006 (JGSEE, 2012) <sup>a3b4</sup>
Trade&Profit	tstmk	Market price of trade straw/kg straw	$P_{tstmk}$	0.006	USD/ kg st	Chinawerooch <i>et al</i> (2014) <sup>a2b1</sup>
	LSmk	Market price of Price of Livestock weight gain/kg DW livestock	$P_{LSmk}$	7.55	USD/ kg DW livestock	OAE, 2010 (from DLD, 2011) <sup>a2b1</sup>

**Table A2. Data for MFA calculation for scenario analysis**

Process	Parameters or constant values					
	Flows	Data	Abbreviations	Values	Units/ y.ha	Sources
Baling	stba	Bale straw	$T_{stba/st1}$	0.64	kg/kg	Calculation data
	Coba	C in Diesel	Coil	0.82	kg/kg	EPA (2005) <sup>a3b2</sup>
		N, P in Diesel	Noil, P oil	0	kg/kg	defined data due to no SFA in oil
		oil consumed/ bale straw	$M_{Coba/stba}$	0.004	kg/kg	Chinawerooch <i>et al</i> (2014) <sup>a2b1</sup>
		Total cost/kg oil	$C_{Coba}$	8.76	USD/ kg	Chinawerooch <i>et al</i> (2014) <sup>a2b1</sup>
			Oil density	$D_{oil}$	0.837	kg/dm <sub>3</sub>
	CO2ba	Carbon in CO2/Carbon from diesel	$M_{Cco2ba/Coil}$	0.99	kg/kg	EPA (2005) <sup>a3b2</sup> ,
Scenario A "Food"						
Mushroom cultivation	sp	spawn DW	DWsp	35	%	Laboratory data <sub>a1b1</sub>
		C in spawn	Csp	0.16	kg/kg	Laboratory data <sub>a1b1</sub>
		N in spawn	Nsp	0.0090	kg/kg	Laboratory data <sub>a1b1</sub>
		P in spawn	Psp	0.00080	kg/kg	Laboratory data <sub>a1b1</sub>
		Spawn/straw	$M_{SP/st3}$		kg/kg	Lardmahalab (2010) <sup>a2b1</sup>
	Nmu	N source for mushroom/ straw for mushroom	$M_{Nmu/st3}$	0.005	kg/kg	Composejunkie.com (2015) <sup>a2b3</sup>
	O2mu	O2 for mushroom/ straw for mushroom	$M_{O2/st3}$	0.325	kg/kg	Calculated data
	flour	Starch for mushroom/ straw for mushroom	$M_{Fl/st3}$	0.003	kg/kg	Calculated data
		C in flour/flour	Cfl	0.42	kg/kg	Rennan <i>et al</i> , (2008) <sup>a2b2</sup>
		N in flour/flour	Nfl	0.0004	kg/kg	Rennan <i>et al</i> , (2008) <sup>a2b2</sup>
		P in flour/flour	Pfl	0.0012	kg/kg	Rennan <i>et al</i> (2008) <sup>a2b2</sup>
	Mu	Mushroom DW	Mu	10	%	Laboratory data <sub>a1b1</sub>
		C in mushroom DW	Cmu	0.27	kg/kg	Laboratory data <sub>a1b1</sub>
		N in mushroom DW	Mmu	0.044	kg/kg	Laboratory data <sub>a1b1</sub>
		P in mushroom DW	Pmu	0.0084	kg/kg	Laboratory data <sub>a1b1</sub>
		Mushroom DW/st	$M_{mu/stmu}$	0.016	kg/kg	Lab.data <sup>a1b1</sup> and Lardmahalab (2010) <sup>a2b1</sup>
	SMS	N in SMS	N <sub>SMS</sub>	0.16	kg/kg	Landschoot and McNitt (2015) <sup>a2b2</sup>
CO2	CO2 mushroom produced/straw for mushroom	$M_{CO2/st1}$	0.46	kg/kg	Calculated data	
H2O	H2O mushroom produced/ straw for mushroom	$M_{H2O/st1}$	0.17	kg/kg	Calculated data	



**Table A2. Data for MFA calculation for scenario analysis (continued)**

Process	Parameters or constant values						
	Flows	Data	Abbreviations	Values	Units/ y.ha	References	
Scenario A "Food" (continued)							
Mushroom cultivation (continued)	CH4	CH4 produced from mushroom cultivation/straw for mushroom	$M_{CH4/st3}$	$7.0 \times 10^{-5}$	kg/kg	Truc <i>et al</i> (2013) <sup>a2b2</sup> in Launio <i>et al</i> (2013) <sup>a2b2</sup>	
	Comu	material for operation 12 mushroom's basket	Ma <sub>Comu</sub>	4.1	kg	Estimated data <sup>a3b3</sup>	
		Material costs for mushroom operation	P <sub>Comu</sub>	24	USD	Calculated data	
	Wcmu	material waste from operation/material used for operation	$M_{Wcmu/Comu}$	1	kg/kg	Calculated data	
Scenario B "Fodder"							
Livestock digestion	Nals	Supplement N from cost-free plants/straw for livestock	$M_{Nals/st2}$	0.0019	kg/kg	Calculated data	
	Ust	Urea for straw treatment/straw for livestock	$M_{Ust/st2}$	0.020	kg/kg	Trac <i>et al</i> (2001) <sup>a2b2</sup>	
	CaO	Lime for straw treatment/straw for livestock	$M_{CaO/st2}$	0.030	kg/kg	Trac <i>et al</i> (2001) <sup>a2b2</sup>	
	Nlul	N-loss from Ulime/N in Urea for treatment	$M_{Nul/Nust}$	0.15	kg/kg	Jayasuriya and Pierce (1983) <sup>a2b2</sup>	
	Coul		Materials for construction of U-lime pit	Ma <sub>Coul</sub>	1400	kg	Base on SUT (2015) <sup>a2b1</sup>
			Construction costs for operating U-lime unit	P <sub>Coul</sub>	48	USD/unit	Calculated data
			1- year Material for operating U-lime unit	Ma <sub>Coulst</sub>	1	kg/unit	Estimated data <sup>a3b3</sup>
			cost of 1 year- material/unit	P <sub>Coulst</sub>	8.7	USD/unit	base on Kijthavorn plastic (2015) <sup>a2b1</sup>
	Coyul	yearly construction costs for operating U-lime unit /total cost	P <sub>Coyal/Coul</sub>	0.27	USD/USD	Calculated data	
	Scenario C "Energy"						
Biogas digester (continued)	Bg	N in biogas	N <sub>Bg</sub>	0.01	0.01	FAO (1996) <sup>a3b3</sup>	
		Biogas Density	D <sub>Bg</sub>	1.15	kg/dm <sup>3</sup>	Joergensen <i>et al</i> (2009) <sup>a3b2</sup>	
		Fraction of Volatile Solid in manure	VS	0.75	kg/kg	Joergensen <i>et al</i> (2009) <sup>a3b2</sup>	
		Biogas Yield	Y <sub>Bg</sub>	0.24	m <sup>3</sup> /kg VS	Steffen <i>et al</i> (1995) <sup>a3b2</sup>	
		Biogas produced/ Manure	$T_{Bg/Ms}$	0.21	kg/kg	Joergensen <i>et al</i> (2009) <sup>a3b2</sup>	

**Table A2. Data for MFA calculation for scenario analysis (continued)**

Process	Parameters or constant values					
	Flows	Data for calculation	Abbreviations	Values	Units/ y.ha	References
Biogas digester (continued)	Cobg	Materials for constructing biogas unit	$Ma_{Cobg}$	390	kg/unit	Base on MOST(2011) <sup>a2b1</sup>
		Material Cost of biogas unit	$P_{Cobg}$	130	USD/unit	Base on MOST(2011) <sup>a2b1</sup>
		Long term material for constructing biogas unit	$Ma_{Cobglt}$	340	kg/unit	Calculated data
		Cost of long term material/unit	$P_{Cobglt}$	20	USD/unit	Calculated data
	Coydg	Average yearly cost for construction biogas unit/total construction cost	$P_{Coydg/Cobg}$	0.19	USD/USD	Base on MOST (2011) <sup>a2b2</sup>
	Biogas Return Value	Energy equivalent of biogas/LPG (kg/kg)	$E_{bg/LPG}$	0.40	MJ/MJ	DEDE (2015) <sup>a2b1</sup> and Ananthakrishnan <i>et al</i> (2013) <sup>a2b2</sup>
Slurry Drying	N <sub>sl</sub>	total volatile N loss from slurry/ total N in fresh slurry	$T_{N_{sl}/N_{sb}}$	0.084	kg/kg	Marchaim, (1992) <sup>a2b3</sup> and Joergensen <i>et al</i> (2009) <sup>a3b2</sup>
		N <sub>2</sub> O/total N loss from slurry	$T_{N_{2}O_{sl}/N_{sl}}$	0.01	kg/kg	IPCC (2006) <sup>a3b4</sup>
Straw Brick	Agf	Fine aggregate/ straw for brick	$M_{Agf/st3}$	33	kg/kg	Allam <i>et al</i> (2011) <sup>a2b2</sup>
	Agc	Coarse aggregate/ straw for brick	$M_{Agc/st3}$	33	kg/kg	Allam <i>et al</i> (2011) <sup>a2b2</sup>
	Cement	Portland cement/ straw for brick	$M_{cm/st3}$	10	kg/kg	Allam <i>et al</i> (2011) <sup>a2b2</sup>
	BR <sub>st</sub>	Brick weight	$M_{Br}$	4.8	kg/brick	Base on Kamwangpruek (2011) <sup>a2b1</sup>
	W <sub>br</sub>	Material Waste from brick production/ total material for producing brick	$T_{Wbr/Mbr}$	0.013	kg/kg	Srichana and Khwalamtarn (2012) <sup>a2b1</sup>
	Cobr	Operation Cost	$P_{Cobr}$	1200	USD	Calculated data
	Brmk	Market price of straw brick/brick weight	$P_{Brmk/Br}$	0.034	USD/kg brick	Base on Kamwangpruek (2011) <sup>a2b1</sup>

**Table A3. MFA data for calculating model "Optimized Scenario"**

Process	Parameters or constant values					
	Flows	Data for calculation	Abbreviations	Values	Unit/ y.ha	References
Bale straw storage	stmu	straw for mushroom/ total bale straw	$T_{stm/stba}$	0.51	kg/kg	Calculated data
	tst	traded-bale straw/ total bale straw	$T_{tst/stba}$	0.022	kg/kg	Calculated data
straw brick production	Br	straw brick	$M_{Br}$	95	kg	Calculated data
	Mbr	Material for straw brick/straw	$M_{Mbr/stbr}$	75.25	kg/kg	Calculated data
	Cobr	Cost of material for straw brick	$P_{Mbr}$	19	USD/kg	Calculated data
Mushroom cultivation	Mam	Material for cultivating mushroom/ straw for mushroom	$M_{Mam/stmu}$	0.029	kg/kg	Calculated data
		Cost of material for cultivating mushroom/ mass material used	$PMam$	2.2	USD/kg	Calculated data
	Gmu	Gas produced from mushroom/ straw for mushroom	$M_{Gmu/stmu}$	0.63	kg/kg	Calculated data
	Comu	Material for operating mushroom cultivation	$M_{Comu}$	2.9	kg	Calculated data
		Cost of material for operating mushroom cultivation	$P_{Comu}$	14	USD	Calculated data
SMS distribution	SMSti	SMS for Tilapia/Total SMS	$T_{SMSti/SMSmu}$	0.1	kg/kg	Base on DOF (2015) <sup>a3b2</sup>
Chemical distribution	Coul	Material for U-lime operation	$MCoul$	1.9	kg	Base on Kongsawat (2015) <sup>a2b1</sup>
Biogas digestion	Mls	fraction of volatile solid in manure slurry	$VSms$	0.20	kg/kg	MOST (2011) <sup>33b2</sup>
		Volume of manure slurry/total volume of biogas digester	$V_{ms/dg}$	0.6-0.75	m <sup>3</sup> /m <sup>3</sup>	MOST (2011) <sup>a3b2</sup>
	Cobg	material for HH digester	$MCobg$	50	kg	Calculated data
Duckweeds pond	Dui	Inoculum size DW/N slurry	$M_{Dui/NSbg}$	0.011	kg/kg	Rodriquez and Preston (1996) <sup>a2b2</sup> and Skillicorn <i>et al</i> (1993) <sup>a2b3</sup>
	CO2du	CO2 for duckweeds/ duckweeds produced	$M_{CCO2duiCdu}$	1.0	kg/kg	Calculated data
	H2Odu	H2O for duckweeds/ CO2 for duckweeds	$M_{H2Odu/CO2du}$	0.41	kg/kg	Calculated data

**Table A3. MFA data for calculating model "Optimized Scenario" (continued)**

Process	Parameters or constant values					
	Flows	Data for calculation	Abbreviations	Values	Unit/ y.ha	References
Duckweeds pond (continued)	Du	C in Duckweeds	$C_{Du}$	0.37	0.37	Landolt and Kandeler (1987) <sup>a3b2</sup>
		N in Duckweed	$N_{Du}$	0.061	0.061	Dewanji and Matai (1993) <sup>a2b2</sup>
		Pin Duckweed	$P_{Du}$	0.014	0.014	Men <i>et al</i> (1995) <sup>a2b2</sup>
		N uptake by duckweeds /N in digester slurry	$M_{Ndu/NSbg}$	0.4	0.4	Zimmo, 2003 <sup>a2b2</sup>
		Duckweeds DW	$DW_{Du}$	0.07	kg/kg	Cross (2012) <sup>a3b2</sup>
	O2du	CO2 from duckweed/O2 for duckweed	$M_{CO2du/O2du}$	1.22	kg/kg	calculated data
Nidu	N loss from duckweed ponds/ N in slurry	$M_{Nidu/NSbg}$	0.10	kg/kg	Zimmo, 2003	
Tilapia	Tfi, Ti	C in Tilapia and Tilapia fingerling	$C_{Tfi}, C_{Ti}$	0.48	0.48	Knud-Hansen <i>et al</i> , 1991 <sup>a2b2</sup>
		N in Tilapia and Tilapia fingerling	$N_{Tfi}, N_{Ti}$	0.095	0.095	Knud-Hansen <i>et al</i> , 1991 <sup>a2b2</sup>
		P in Tilapia and Tilapia fingerling	$P_{Tfi}, P_{Ti}$	0.20	0.20	Selfnutrientdata (2015) <sup>a2b3</sup>
		Tilapia and Tilapia fingerling DW	$DW_{Ti}, DW_{Tfi}$	0.30	kg/kg	Knud-Hansen <i>et al</i> (1991) <sup>a2b2</sup>
	O2tir	O2 consumed by Tilapia/total C from RSM residues for fish feed	$M_{O2/CFti}$	0.84	kg/kg	Mueller and Bauer (1996) <sup>a2b2</sup>
	Tfi	Tilapia fingerling/ 1 year cultivated Tilapia	$M_{Tfi/Ti}$	0.02	kg/kg	DOF <sup>a3b1</sup>
	Stip	N for tilapia/total N for Tilapia	$M_{Stip/Sti}$	0.21	kg/kg	Mueller and Bauer (1996) <sup>a2b2</sup> and Knud-Hansen <i>et al</i> , 1991 <sup>a2b3</sup>
	CO2tr	C in CO2respiration/ C in total substances for Tilapia	$M_{CO2tr/C/Sti}$	0.24	kg/kg	Mueller and Bauer (1996) <sup>a2b2</sup>
	Nlti	N loss from Ti pond/ N in effluent and sediment from pond	$M_{Nlti/NESti}$	0.38	kg/kg	Gross and Boyd (1999) <sup>a3b3</sup>
	Coti	Density of tilapia in pond	$D_{ti}$	2	fish/m <sup>2</sup>	DOF (2015) <sup>a3b1</sup>
		Oil for pumping 40 m <sup>3</sup> /hr/Ti	$M_{Coti/Ti}$	0.0070	kg/kg	base on data from DOF (2015) <sup>a3b1</sup> , EPA <sup>a3b2</sup> , Hinota (2015) <sup>a2b1</sup>
		oil consumption of water pump	$O_{pu}$	0.33	dm <sup>3</sup> /hr	Example data from pump Hinota (2015) <sup>a2b1</sup>

**Table A4. Economic data for an exemplary small farm in Thailand**

( exchange rate at 1 USD= 30 BHT)

Data	Types	Values	Units	references
Unbale straw	Market price at farm	0.0060	USD/kg	Chinawerooch et al (2014) <sup>a2b1</sup>
Bale straw	Market price at farm	0.067	USD/kg	Chinawerooch (2014) <sup>a1b2</sup>
Urea fertilizer	Market price	0.50	USD/kg	OAE(2011) <sup>a2b1</sup>
Ammophos fertilizer	Market price	0.50	USD/kg	OAE (2011) <sup>a2b1</sup>
Lime (CaO)	Market Price	0.060	USD/kg	Pantip.com (2005) <sup>a3b3</sup>
Live Cow DW	Market price at farm	5.86	USD/kg	OAE(2009) in DLD Thailand (2012) <sup>a2b1</sup>
500 g Tilapia DW (middle size)	Market price at farm	3.9	USD/kg	DOF and OAE (2012) <sup>a2b1</sup>
10 g Figerling Tilapia DW	Market price	2.25	USD/kg	DOF(2011) <sup>a2b2</sup>
Mushroom	Market price	25	USD/kg	Banmuangkam (2015) <sup>a2b2</sup>
Mushroom spawn DW	Market price	3.0	USD/kg	Mushroom dealer (2015) <sup>a2b1</sup>
Flour	Market price	0.67	USD/kg	Infoquest news (2011) <sup>a1b1</sup>
0.3 kg Basket	Market price	1.3	USD/piece	Thethaitool.com (2015) <sup>a1b2</sup>
0.5 kg Plastic cover size 2.5x4.5 m <sup>2</sup>	Market price	4.3	USD/piece	Kijthavorn plastic (2015) <sup>a1b2</sup>
5.25 kg Soft PVC 3.5x6 m <sup>2</sup> , 0.25 mm	Market price	21	USD/piece	Marketintrend.com (2011) <sup>a2b1</sup>
1.9 kg water proof-blue sheet plastic for wrapping 4x6 m <sup>2</sup>	Market price	2.1	USD/piece	Piboolsin (2013) <sup>a2b1</sup>
10.5 kg plastic tank 200 l (second hand)	Market price	17	USD/unit	www.chiangraifocus.com <sup>a3b3</sup>
6.2 kg Brick	Market price	0.16	USD/brick	Kamwangpreuk (2011) <sup>a2b1</sup>
Coarse aggregate 1 m <sup>3</sup> (1500 kg)	Market price	12	USD/m <sup>3</sup>	Kamwangpreuk (2011) <sup>a2b1</sup>
Fine aggregate 1 m <sup>3</sup> (1500 kg)	Market price	15	USD/m <sup>3</sup>	Kamwangpreuk (2011) <sup>a2b1</sup>
50 kg bag of Cement Portland	Market price	4.3	USD/bag	Kamwangpreuk (2011) <sup>a2b1</sup>
250 kg concrete pit and cover plate diameter 80 cm	Market price	6.9	USD/unit	MOC Thailand (2011) <sup>a2b1</sup>
Electricity cost for producing brick	Electricity cost	0.0033	USD/brick	Kamwangpreuk *2011) <sup>a2b1</sup>
200 l biogas digester and reservoir	Material and installing cost	83	USD/set	Council of Song Peenong's community (2015) <sup>a1b2</sup>
Diesel oil	Market price	0.98	USD/litre	BOT (2011) <sup>a2b1</sup>
LPG	Market Price	0.65	USD/kg	BOT (2011) <sup>a2b1</sup>
Labour fee for skilful brick maker	Labour fee	0.017	USD/brick	Kamwangpreuk (2011) <sup>a2b1</sup>
Daily worker	Labour fee	5.3	USD/day	NESDB (2011) <sup>a2b1</sup>

## **Curriculum Vitae** **Kulwadee Tongpubesra EISINGERICH**



Born in Chiang Mai, Thailand

Married to Mr. Thorsten EISINGERICH, Minister and Director for Press and Information at the Austrian Embassy Washington D.C.; 1 daughter Thara (9 years old)

Presently living in Washington D.C., USA

email address: eisingerich@gmail.com

### **Education**

B.Sc. with Honors (Biotechnology) from King Mongkut's Institute of Technology Ladkrabang (KMITL), Bangkok Thailand (1994)

M.Sc. (Biotechnology) from Mahidol University, Bangkok Thailand (1998)

Dr.rer.nat. (Resource and Waste management) at the Faculty of Civil Engineering, TUWien, Vienna, Austria (2015)

### **Scope of scientific researches**

Past: Biotechnology focusing on Bioprocess engineering and fermentation technology for waste utilization

Present: MFA and productive use of agricultural waste in Emerging Economies

### **Career and Main Activities**

- |            |  |
|------------|--|
| 1994-2004  | University Lecturer<br>Faculty of Science, King Mongkut's Institute of Technology (KMITL),<br>Bangkok Thailand |
| 1999-2001  | Secretary General of the Faculty Senate KMITL, Thailand  |
| 2004       | Assistant Professor<br>Faculty of Science, KMITL Thailand  |
| 2004       | Thai-Austrian coordinator for the Austrian Relief Team to help Tsunami victims in Phuket Thailand              |
| 2006-2010  | Maternity Leave  |
| 2010       | Environmental Management Branch, United Nation Industrial Development Organization (UNIDO), Vienna Austria     |
| 2011-2012  | Initiator, organizer, and Coordinator for Project "Thai Music Festival" 21-23 March 2012, Canberra Australia   |
| 2011- 2012 | Newsletter Editor of DSC (Deputy Spouse Club), Canberra, Australia   |

### **Main Awards and Scholarships**

- 1988 H.R.H. Crown Princess Sirinthorn's 3<sup>rd</sup> Award for Thai Traditional Band at the "5<sup>th</sup> Thai Music Competition at high school level"
- 1988 H.R.H. Crown Princess Sirinthorn's 2<sup>nd</sup> Award for Thai Traditional composer (lyrics) at the "5<sup>th</sup> Thai Music Competition at high school level" (1988)
- 1994 Scholarship to support outstanding undergraduate-students to become lecturers in Public Universities, awarded by the Ministry of University Affairs, Thailand

### **Language**

Thai, English, basic German