



DIPLOMARBEIT

Innovations in Prefabricated High-Rise Timber Construction

ausgeführt zum Zwecke der Erlangung des akademischen Grades
eines Diplom-Ingenieurs /Diplom-Ingenieurin
unter der Leitung

Klaus Zwerger
Ao.Univ.Prof. Mag.art. Dr.phil.

253.6
Institut für Gestaltungslehre und Entwerfen

eingereicht an der Technischen Universität Wien
Fakultät für Architektur und Raumplanung

von
Ivana Milijanovic
0425233

The two most important things for me are time and health. This thesis explores these two topics within high-rise building. It presents prefabrication as an efficient way of construction while concentrating on ecologically friendly design. It is various factors that influence the final outcome of a project. Within this thesis, throughout five example projects, the importance has been stressed on the complete life cycle of a building. As particular points of interest following topics have been discussed: timber as a possible material choice, prefabrication of a construction system, digital fabrication and design for disassembly.

Gesundheit und Zeit sind für mich die beiden wichtigsten Dinge. Diese Arbeit untersucht diese beiden Themen im Zusammenhang mit Hochhäusern. Vorfertigung unter Berücksichtigung eines umweltfreundlichen Designs stellt dabei die effiziente Möglichkeit des Aufbaus dar. Das entgeltige Ergebnis eines Projektes wird von verschiedenen Faktoren beeinflusst. Anhand von fünf Beispielprojekten beschäftigt sich diese Arbeit mit der Bedeutung des gesamten Lebenszyklus eines Gebäudes. Der Schwerpunkt wurde speziell auf Holz als Material, Vorfertigung von Konstruktionssystem, digitale Fertigung und Design für die Demontage gelegt.

Table of Contents

- Problem statement** **6**

- Chapter 1. Influence of materials** **8**
 - 1.1. Environmental aspects of materials 8
 - 1.2. Building energy 10
 - 1.3. Mid and high-rise building. 10

- Chapter 2. Timber composites** **14**
 - 2.1. Adhesives in structural composite timber 17
 - 3.2. Fire regulations and timber construction 20
 - 3.3. Durability 21
 - 3.4. Building codes 21
 - 3.5. Cost. 22

- Chapter 3. Prefabricated system building** **24**

- Chapter 4. Systems in timber high-rise** **30**
 - 3.1. Introduction. 30
 - 3.2. Linear 32
 - 3.3. Point 32
 - 3.4. CLT 34
 - 3.5. Glulam 39
 - 3.6. Hybrid systems 41
 - 3.7. Joints. 46

- Chapter 5. Design for disassembly** **48**
 - 4.2. Connectors and design for disassembly 54

- Chapter 6. Digital prefabrication** **58**

- Chapter 7. Case studies** **62**
 - 6.1. Austria. 62
 - 6.3. Switzerland 68
 - 6.4. Norway 74
 - 6.5. Australia 80
 - 6.6. The Netherlands. 86

Problem statement

Architecture faces a number of issues today including urbanization and climate change.

In next 20 years, 3 billion people will need a new home. 50% of the world's population today is living in cities and the studies show that by 2040 this number is to rise to around 70%.¹ The only way to expand the cities is to go upwards and build higher. London for example already has 236 planned high-rise towers of more than 20 storeys.² Nearly half have already been approved and about a fifth are now being built, according to local studies.

European council for an energy efficient economy has set climate protection targets to be put into place by 2020. The EU Energy Performance of Buildings Directive (the main

European legislative instrument for improving the energy efficiency of Europe's building stock) announced new energy standards that will require that all new buildings that are to be constructed in Europe after 2020, will have to be nearly energy-neutral. The new guidelines will take effect for all new public buildings constructed in the European Union after 2018 and apply to all residential and office buildings after 2020.³ At the moment the New Energy Performance Certification (EPC) laws include:

- Reduction in greenhouse gas emissions of at least 20% below 1990 levels
- 20% of energy consumption to come from renewable resources
- 20% reduction in primary energy use to be achieved by improving energy efficiency.

¹ Green M.; Why we should build wooden skyscrapers; at TED Conference; Feb 2013; retrieved from http://www.ted.com/talks/michael_green_why_we_should_build_wooden_skyscrapers/transcript?language=en; 5.2.2015

² New London Architecture, GL Hearn; 236 Tall Buildings Planned for London; 03.2014; retrieved from http://www.glhearn.com/SiteCollectionDocuments/News%20articles/NLA_GLHearn_Dataset_March2014.pdf; 5.2.2015

³ EUR-Lex; Directive 2010/31/Eu Of The European Parliament And Of The Council on the energy performance of buildings; 19.05.2010; pp.1; in Official Journal of the European Union; 18.6.2010 retrieved from <http://eur-lex.europa.eu/LexUriServ/LexUriServ.do?uri=OJ:L:2010:153:0013:0035:EN:PDF>; 5.2.2015

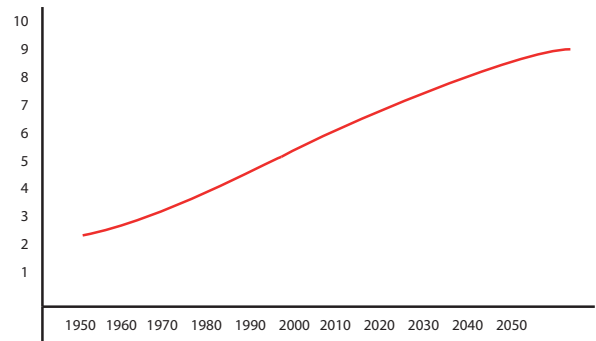

Fig.1: World population 1950 - 2050

The plan is to strive for buildings with Energy Performance Certification (EPC) that equals 0.0

Within the building sector these two factors (the urbanisation and energy issues) require architects to start thinking of new ways to build homes. This thesis analyses prefabricated timber high-rise building as a possible answer to these issues.

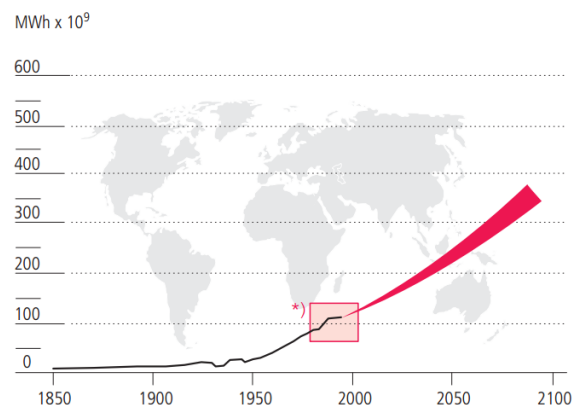

Fig.2: Global energy use 1850 - 2100

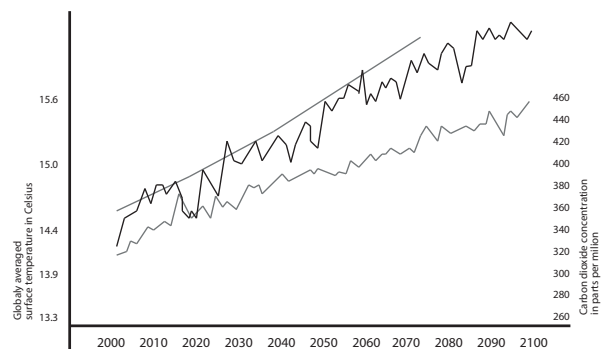

Fig.3: Global average temperature and CO2 concentration 2000-2100

Chapter 1: Influence of materials

Construction industry (as a whole) with its conventional construction methods today consumes 40% of our energy and resources as well as generating 40% of our waste and 36% of EU's greenhouse gases. The branch is also responsible for 60% of the world's transport routes.⁴ Improving the energy efficiency in building is crucial for meeting the EU's climate change goals. One way to approach this issue is to use materials that are more ecologically friendly.

Environmental aspects of materials

Environmental impact is caused by the extraction of resources and by the later emissions of those resources. The assessment of materials regarding their environmental impacts is carried out through framework of Life Cycle Assessment. "Life Cycle Assessment (LCA) is a tool for the systematic evalu-

⁴ United Nations Environment Programme; Buildings And Climate Change: Status, Challenges and Opportunities; 2007; pp:1-8; retrieved from <http://www.unep.fr/shared/publications/pdf/DTIx0916xPA-BuildingsClimate.pdf>; 5.2.2015

ation of the environmental aspects of a product or service system through all stages of its life cycle....The International Organisation for Standardisation (ISO), has standardised this framework within the series ISO 14040."⁵

Life Cycle Assessment divides building materials into following categories:

- Minerals
- Wood products
- Metals
- Synthetic materials
- Insulation materials (made from minerals or synthetics)⁶

Diagram above shows the results of analysis done by PE International company stating the overall comparison of embodied energy of the different categories. PE International is the international market leader in strate-

⁵ United Nations Environment Programme; Life Cycle Assessment; retrieved from <http://www.unep.org/resourceefficiency/Consumption/StandardsandLabels/MeasuringSustainability/LifeCycleAssessment/tabid/101348/Default.aspx>; 5.2.2015

⁶ Knaack U., Bilow M., Auer T., Hilderbrand L.; Energy; Imagine 05 series; 010 Publishers, Rotterdam 2011; pp:29

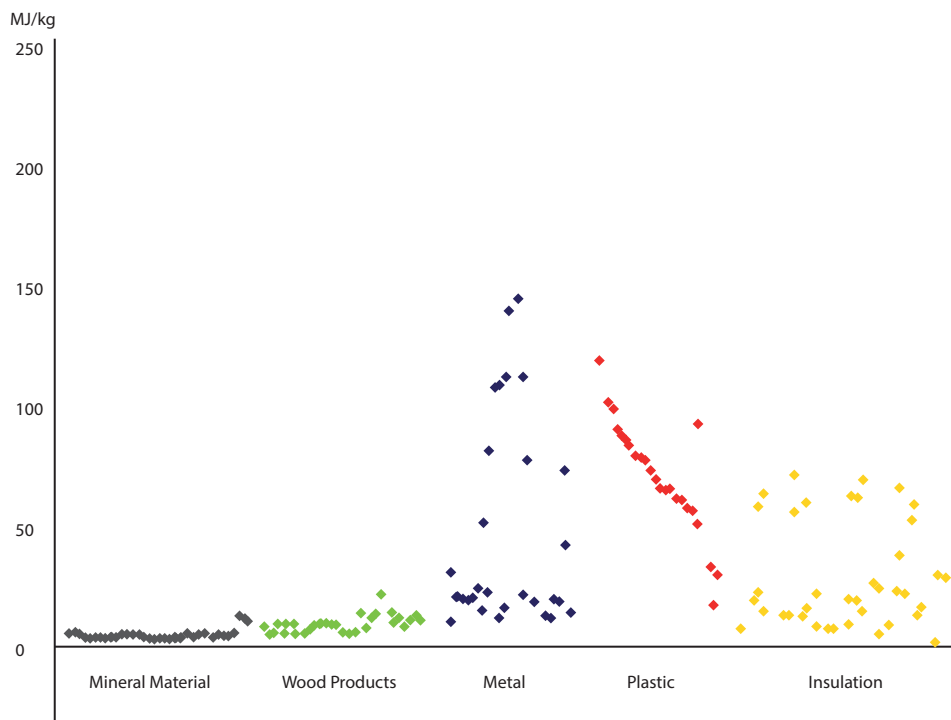

Fig.4: Material comparison

gic consultancy, software solutions and extensive services in the field of sustainability.⁷ Embodied energy is the energy needed for the production, maintenance and disposal of a material. The analysis (fig.4) shows that mineral and wood products have the best energy scores (lowest embodied energy) :

- Minerals 0.5 -5MJ/kg
- Wood 5-15MJ/kg
- Synthetics 30 -160 MJ/kg
- Metals up to 155MJ/kg

Mineral materials include: concrete, cellular concrete, plaster, glass and mineral wool. They are long lasting materials. Their bonding is permanent and irreversible which makes them hard for reuse, deconstruction or recycling. Once the building comes to the end of its life cycle these materials usually end up as waste or are used in road construction. It

should also be kept in mind that minerals do show low energy scores, but are heavy materials when looked at the quantities needed in relation to its function in a building. (e.g. :1 kg of cement has very little function, this material is usually used in big quantities, which in turn raises its energy score). The energy needed for recycling and possible transport of big loads of heavy materials, is usually very high, which puts into question the efficiency of the process.

Wood products are a very efficient material when considering weight to performance ratio. (e.g.: steel is 10 times harder then wood but 20 times heavier). Processing wood has a lower impact on the environment then processing steel or concrete for example. Wood is also an easily reusable material. It can be re-used, down-cycled or recycled depending on it's original use. Wood may have a little higher energy assessment then minerals, however

⁷ PE International; retrieved from <http://www.pe-international.com/international/company/about-pe-international/>; 5.2.2015

if the whole life cycle is taken into account this statistic changes. At the end of life cycle, wood can be burnt which will generate more energy than was needed for extraction.

Building energy

When it comes to energy efficient building three different categories of energy need to be considered:

1. Transportation energy is the amount of energy needed to transport all the building components to the site where it will be built.

2. Operational energy is the amount of energy needed to operate a building.

3. Embodied energy is the amount of energy needed to construct a building and dispose of it after its end of life.

Architects today are very aware of the operational energy and this is becoming an ever more important factor when designing a

building. In comparison, the embodied energy factor is rarely considered in the design process. This should be an important factor as the embodied energy can "account for 50% of the overall energy usage of a building if its operational energy is low."⁸

Also to be taken into account is a life span of a building. Energy efficient building should be looked at in terms of a buildings' complete life cycle. In Switzerland this is assumed to be 30 years, in Germany between 50 and 100 years.⁹

Mid and high-rise building

Currently most mid and high-rise buildings are built using predominantly 2 materials : steel and concrete. These two existing materials have been excellent choices and will continue to be important materials in the construction of all buildings in the future.

⁸ Knaack, Bilow, Auer, Hilderbrand; 2011; pp:27
⁹ Knaack, Bilow, Auer, Hilderbrand; 2011; pp: 39

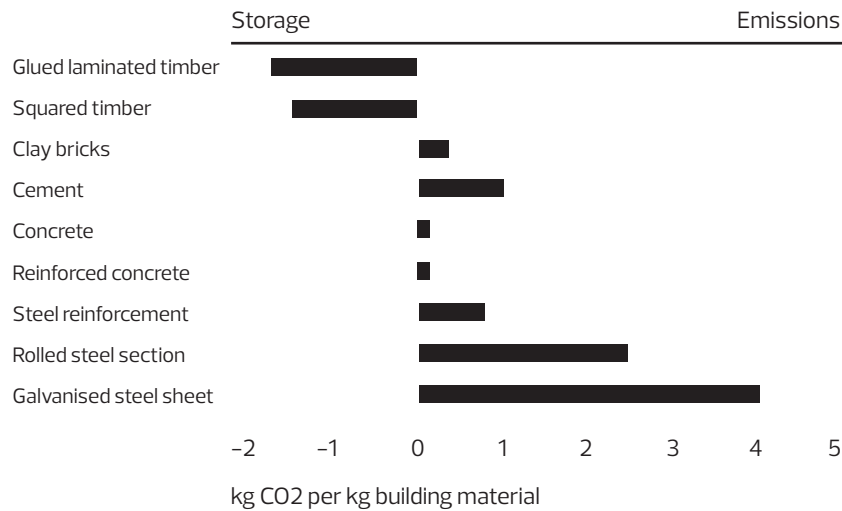

Fig.5: CO2 storage and emissions from different materials

However, both concrete and steel have a large carbon footprint and are highly energy intensive materials to produce. 8 % of greenhouse gas emissions today come from these 2 materials alone.

Why build with timber

A way to address the problem of too much CO2 production is to reduce the emissions and to find a way to store the emissions that we produce. Wood, is the only building material that does both. Wood is a building material that is manufactured by nature, grown by the power of the sun, a material that is renewable, durable and strong. It gives off oxygen and has the ability to bind CO2. If we take wood and put it into an object, a building gains the capacity to store the carbon. One ton of wood collects almost one ton of CO2 out of the atmosphere. In comparison one ton of cement exposes one ton of CO2.

Figure 5¹⁰ shows the relation of CO2 emission and storage capabilities of different materials. It is however disputable why according to Josef Kolb, the CO2 storage has been rated higher in laminated timber material in comparison to natural timber.

Wood is the man's oldest building material. In central and northern Europe especially, but also in other parts of the world that have abundant forest areas timber was the first used building material.

In the 19th century industrialisation happened. New methods of processing and building were discovered and led to a boom in building with iron, steel, concrete and synthetics.

In the 20th century, in the crisis years (WWI, WWII) wood was back in demand as it is an easily available raw material. However as the economical situation improved the interest

¹⁰ Kolb J.; Systems in Timber Engineering: Load bearing Structures and Component Layers; Birkhauser; Basel; 2008; pp: 19

shifted to high tech materials and new horizons. New materials enabled us to build better, higher, different. Steel and concrete allowed us to build what we could not build with wood.

However in the 21 century, timber as a material has “undergone the most effective developments for construction practice.”¹¹ This factor is the reason to now again revisit the building possibilities with this material considering it's superiority over other materials in terms of its ecological benefits.

¹¹ Kolb J.; 2008; pp: 11



Fig.6: Timber composites

Chapter 2: Timber composites

Timber is graded into two categories based on its intended use: load bearing and non-load bearing. Structural timber is primarily used as load-bearing timber. It is graded based on strength classes and its most important properties are strength, deformation properties and durability. Non-load-bearing timber is graded based on its quality classes where its durability and surface properties are most important. It is used for space-dividing functions as well as cladding.

In the 1990's came a development of wood engineered materials that are today known as Mass Timber panels.

Mass Timber is defined as solid panels of wood, engineered for strength through laminations of different layers. The panels vary in size but can range up to 20m x 2.4m while thickness can range from a few to over 40 centimetres. These are considered very large and very dense solid panels of wood when it

comes to constructions.

The approved moisture content for solid wood panels (at KLH manufacturer) is 12% (+/-2%).¹²

The primary mass timber products, from engineered structural composite lumber (SCL) that are at the moment being used in high-rise constructions are :

- Cross Laminated Timber (CLT)
- Laminated Strand Lumber (LSL)
- Laminated Veneer Lumber (LVL)
- Glue laminated wood (Glulam)

Cross laminated timber (CLT) is an engineered product that consists of multiple layers of timber that are bonded together by structural adhesives, alternating the grain directions of each layer, to produce a solid, load-bearing timber panel with each layer of

¹² KLH; Made for building Built for living Cross laminated Timber; KLH Massivholz GmbH; Feb 2013; pp:4 retrieved from http://www.klh.at/fileadmin/klh/kunde/2011/Download/Kreuzlagenholz_engl.pdf; 12.2.2015

the panel alternating between longitudinal and transverse lamellae. Multiple perpendicular layers are built up to create CLT panels for use as structural elements. CLT panels can be oriented vertically and horizontally. In mid- and high-rise construction the CLT panels are used as load-bearing walls and floors. Walls typically consist of three to five layer panels, whereas floors consist of five or more layers for greater stability. CLT panels can be designed to create internal and external partitions within the structure that makes their use practical for housing units in residential buildings. One of the primary benefits of CLT panels is the use of off site prefabrication. Holes and notches in panels can be pre-cut prior to arrival to site. This minimizes work on site, reduces construction time and costs, and increases the accuracy of structural components and quality of workmanship. Cross-laminating layers of wood veneer improves the structural properties by dis-

tributing the along-the-grain strength of wood in both directions, and this means that solid wood panels can be used to form complete floors, walls and roofs. The advantages this offers are quite exciting; timber panels are much lighter than concrete, more easily worked and easier and safer to erect.

Gluing at high pressure reduces the timbers expansion and shrinkage potential to a negligible level. The result is a rigid structural timber member that can be used both vertically and horizontally to construct a buildings frame.¹³ Within KLH (manufacturer from Austria) pressing power of 0.6 N/mm² is used when gluing CLT layers.¹⁴

CLT layers can have slightly different properties depending on their positions. There are 3

¹³ Mils F.; Cross Laminated Timber Frames; in Briefing note13; Apr 2010; pp:2; retrieved from <http://www.willmott-dixon-group.co.uk/assets/c/r/cross-laminated-timber-frames-v3-april-2010.pdf>; 5.2.2015

¹⁴ KLH; Feb 2013; pp:4

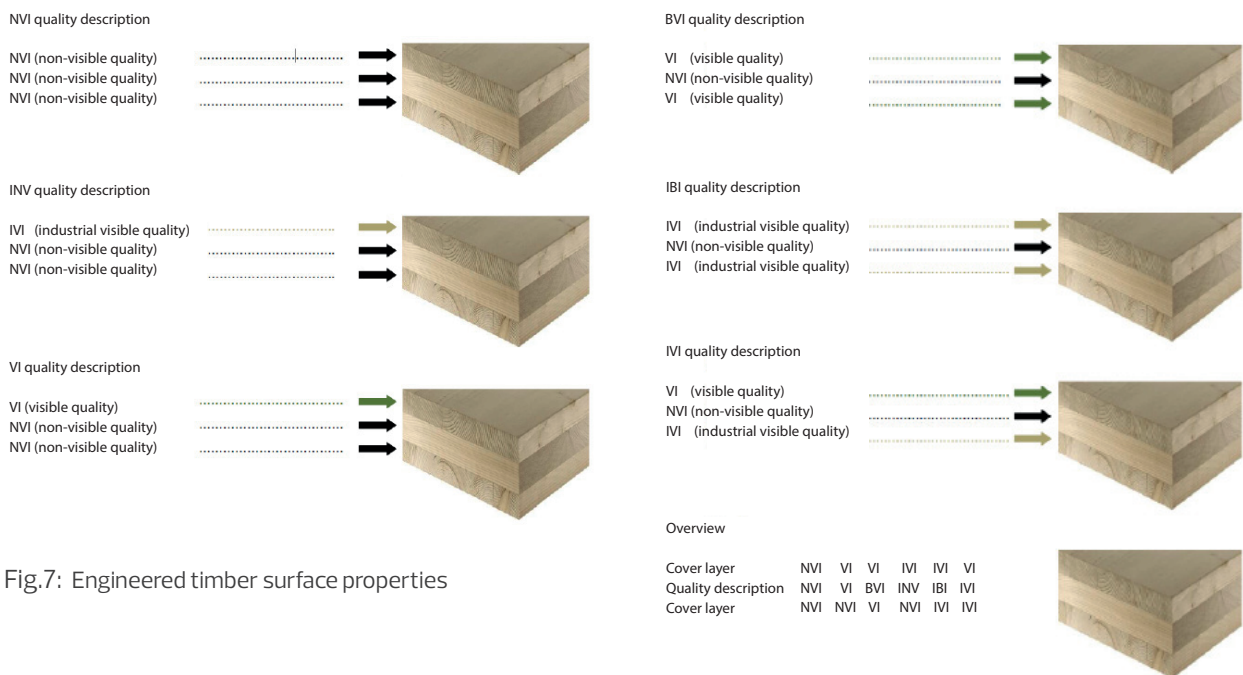

Fig.7: Engineered timber surface properties

categories:

- NVI (non-visible quality)
- IVI (industrial visible quality)
- VI (visible quality)

Laminated veneer lumber (LVL) is composed of multiple layers of thin wood veneers, approximately 3 mm thick, which are laminated parallel to each other under heat and pressure. Slicing the timber into thin veneers and laminating them together reduces the effect of imperfections in the wood, resulting in improved structural performance compared to solid sawn timber members.

Laminated Strand Lumber (LSL) is made from a matrix of thin chips.

Glue laminated wood (Glulam) is an engineered product that consists of smaller pieces of wood, usually 50 mm x 100 mm, which are bonded together with durable, moisture-

resistant structural adhesives. This produces a structural element that is stronger than solid sawn lumber as it is more homogenous and reduces the impact of knots and other imperfections. It has "greater tensile strength than steel, and can resist compression better than concrete".¹⁵ Similar in size and structural application as solid sawn lumber, Glulam elements are commonly used as structural beams and columns.

The analysis performed withing the Tall Wood Study carried out by Michael Green Architects from Canada, shows that types of structural composite timber can be used in different variations resulting in slight changes in dimensioning of the element types and that panel type will have an impact on specific details of the design. For example, the bearing of steel beams on panel ends will be

¹⁵ Harris M; Wooden high-rise buildings; in Engineering and Technology Magazine; 17.9.2012; retrieved from: <http://eandt.theiet.org/magazine/2012/09/wood-goes-high-rise.cfm>; 15.2.2015

affected by grain orientation and will be lower in CLTs, which have a mixture of vertical and horizontal layers (compared to LVL). On the other hand, the shear capacity of LSL and LVL panels at this time is higher than that of CLTs. However, CLTs can be readily produced in thicker panels.¹⁶

Adhesives in structural composite timber

In the production of timber engineered products different adhesives are being used. The adhesives are used as a bonding agent between the layers but they also transfer some of the stresses between adjoining wood fibres. The adhesives can vary depending on the manufacturer. The selection, application, and curing of adhesives are controlled at the point of manufacture with extensive testing of physical properties, reliability of bond, performance under environmental factors and emission of VOCs (volatile organic compounds).

Adhesives based on formaldehyde

Formaldehyde based adhesives can contain: Phenol Formaldehyde (PF), Phenol Resorcinol-Formaldehyde (PFR) or Polymeric Methylene Diphenyl Diisocyanate (pMDI). Different types of formaldehyde compounds have different levels of chemical stability and hence

¹⁶ Mgb Architecture + Design; The Case For Tall Wood Buildings; 2.22.2012; pp:83; retrieved from <http://cwc.ca/wp-content/uploads/publications-Tall-Wood.pdf>, 12.2.2015

different emissions of VOCs (volatile organic compounds) under different environmental conditions. Depending on these levels they can impact human health and comfort. Formaldehyde is a naturally occurring substance that is present in the atmosphere, our bodies and even some vegetables, but depending on levels of VOC's emissions it is also an irritant and potential carcinogen. For this reason the use of the adhesives is strictly controlled by the manufacturers.

- Phenol Formaldehyde (PF) is an adhesive derived from the chemical reaction between phenolics and formaldehyde which create a strong bond that is necessary for the composition of any exterior wood adhesive application and eliminates the possibility of VOC emissions.

- Phenol Resorcinol Formaldehyde (PRF) has similar properties, but is more reactive than phenol-formaldehyde meaning that curing is faster and takes place at room

temperature. LVL and LSL manufacturers typically use a blend of PF and PRF.

- Polymeric Methylene Diphenyl Diisocyanate (pMDI) is an isocyanate based adhesive. As is the case with PF and PRF, cured pMDI forms a strong bond that is not susceptible to the hydrolysis reaction that would cause the adhesive to release VOCs. Properly hardened pMDI is inert and is proven to be well below any emissions standard. pMDI is limited in use due to higher costs and its unique handling procedures.¹⁷

- Urea-formaldehyde (UF) is used in interior and non-structural wood products. UF is more economical than PF, PFR and pMDI but more readily releases VOCs into the environment when it is sawn or when it is exposed to moisture. UF is not used in Structural Composite Lumber, nor in CLT.¹⁸

¹⁷ Vacca Phil, LP SolidStart Engineered Wood Products and Formaldehyde Emissions, Oct 21, 2009; http://www.jpcorp.com/Resources/Literature/SolidStart_Rim_Board/Green_Briefs/LP_EWP_Formaldehyde_Emissions/; 12.2.2015

¹⁸ EmeryJ.; Formaldehyde Release from Wood Products; Washington D.C.; 1986; chapter 3; retrieved from <http://rosboro>.

The emissions from PF, PRF, and pMDI are well below the standard levels that are considered harmful.

LVL and LSL testing performed by Institute for Research in Construction 2009 has shown that formaldehyde emissions from these products range from 0.02 ppm to 0.04 ppm. Testing conducted by FP Innovations in 2011 has shown that a CLT panel emits between 0.015 ppm to 0.05 ppm.¹⁹

Adhesives free from formaldehyde

A more ecologically friendly adhesive is Polyurethane. It was developed by Otto Bayer in 1937 and typical examples of its use include coating systems for waterproof, windproof and breathable clothing, articles for medical technology, implants, flexible foams for cushions and mattresses, and rigid foams for the construction industry. Since the mid 1980s,

com/pdfs/WoodPanelsFormaldehyde.pdf; 12.02.2015
19 Mgb Architecture + Design; The Case For Tall Wood Buildings; 2.22.2012; pp:41; retrieved from <http://cwc.ca/wp-content/uploads/publications-Tall-Wood.pdf>; 12.2.2015

Bayer Material Science has been working with the partner Purbond in the field of engineered wood adhesives. The adhesive is now sold under a name Purbond. KLH is one of the companies that uses it. The individual layers of wood are glued together with adhesive applied to the entire surface. The percentage of adhesive is 0.2 kg/m². In the first step of the bonding process, the water contained in the substrate (for example: the moisture in the wood) reacts with some of the isocyanate to form amine, splitting off carbon dioxide. As with carbonated drinks, the adhesive begins to foam up slightly. The amine then reacts very quickly with a further isocyanate group and results in a crosslinked structure.²⁰

Within KLH, gluing takes place using solvent-free and formaldehyde free PUR adhesive which has been tested in accordance with DIN 68141 and other strict criteria of MPA

20 Bayer material science; Purbond; Adhesives for modern timber construction; pp2-3; retrieved from http://www.klh.at/file-admin/klh/kunde/2011/Kreuzlagenholz/Verleimung/Purbond_-_Adhesives_for_modern_timber_construction.pdf; 12.2.2015

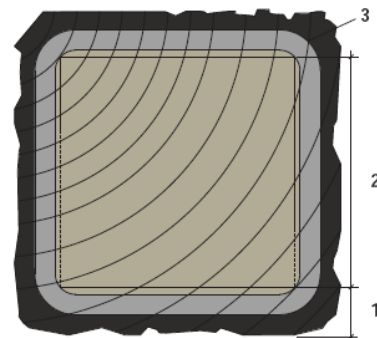

Fig.8: Timber charring principle

Stuttgart, and approved for the production of load-bearing and non-load-bearing timber components and special constructions in accordance with DIN 1052 and EN 15425.²¹

Purbond states the following advantages:

- Proven to be toxicologically safe.
- Less environmental impact – they do not react further with substances in the environment.
- Odourless
- 100 % solids without solvent.
- Easy handling as the adhesives are applied directly from the can to the joints of the timber parts.²²

Fire regulations and timber construction

Wood burns and this is the biggest issue that the general population has when they hear about wooden skyscrapers. The fact is that they would just feel safer in a steel building. This might partially be due to not recognising the difference between the behaviour of light timber construction used for lower building and heavy timber construction used in high rise building. Heavy timber elements simply exhibit different fire performance compared to light timber. It has been proven that solid wood structural elements can meet the requirements of 2 hour fire-resistance rating as required for high buildings.²³ Two different approaches can be taken to assure this.

a) Charring Method

Heavy timber elements that are used in mass timber construction have a thickness that allows for a charr layer to form once the wood

²¹ KLH; Feb 2013; pp:4

²² Purbond; Adhesives for modern timber construction; pp:3; retrieved from http://www.mnamai.it/uploads/pdf/KLH-5/Purbond_-_Adhesives_for_modern_timber_construction.pdf; 12.2.2015

²³ Gerard R., Barber D., Wolski, A.; Fire Safety Challenges of Tall Wood Buildings, Quincy, MA, 2013; pp4-5

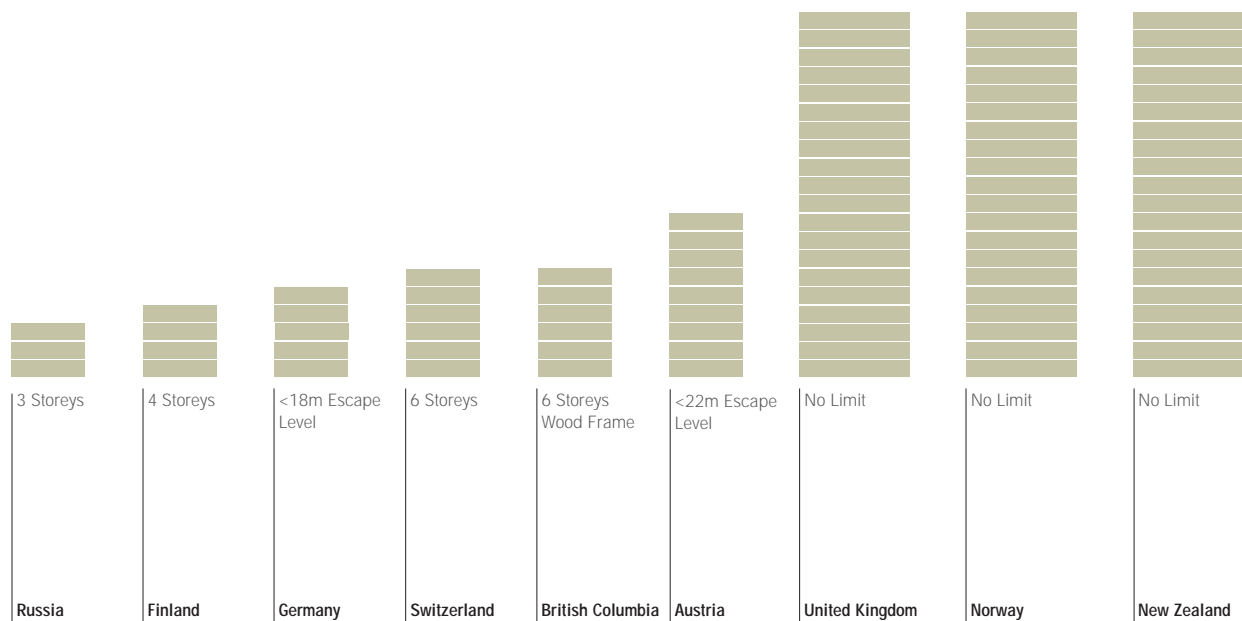

Fig.9: Allowed heights of timber constructions depending on country

starts burning. This is a layer of incompletely combust wood that then acts as an insulator slowing down the burning process, insuring that the structure passes the safety regulations testing.

b) Encapsulation Method

Fire resistance can also be achieved by applying 2 layers of fire-rated gypsum board to the underside of floors and throughout the building.

Durability

There is a strong perception that concrete is a preferable material choice with better long-term value and performance. Durability of timber depends on its species and maintenance. Different species have different quantities of resistant substances. For example Oak is one of the most resistant types, and Scots pine and Larch are also very resistant

Building codes

Building regulations play a big part in an architect's design and they are also one of the barriers when it comes to high-rise building with timber. They shape and limit the realisation of ideas. They are specific to individual countries and are based on the environmental and social factor besides technical possibilities. It is to be noted that many of the building codes were at first approved based on light frame building with wood. However, Mass Timber products offer significant benefits over light wood frame techniques in terms of fire, acoustic performance, and structural performance, scale, material stability and construction efficiency.²⁴ This is why building codes are being revised, and changed according to the new studies and new findings.

²⁴ Mgb Architecture + Design; 2012; pp:192

Costs:

The analysis conducted by Michael Green Architects suggests that the cost of timber constructions are comparable to those done in concrete. Their study compares the potential costs of building with concrete frame and with their own Mass Timber building approach called FTTT (Finding the Forest through the Trees).²⁵ Expected price are calculated based on the building cost in Vancouver.

	12 Storey height	20 Storey height
Concrete frame:	\$ 17 550 800	\$ 30 097 200
FTTT: (charring method)	\$ 17 518 000	\$ 30 297 100
FTTT: (encapsulation method)	\$ 17 650 200	\$ 30 989 900

25 Mgb Architecture + Design; 2012; pp:17

Chapter 3: Prefabricated system building

Prefabricated building is a name for system building where the components are pre-planned and pre-manufactured before being assembled into a final product. The aim is for a more efficient and more cost effective production. Main characteristic of system building is that such a system does not relate to a specific building. It is not an answer for a specific idea but rather a set of options that can be applied as a universal solution in multiple cases.

Building systems include production of building elements that can be assembled on or off site. Prefabrication includes all systemized off site manufacturing of components and elements.

From the point of view of architecture prefabrication has positive and negative sides. Prefabrication allows for development of technical knowledge: connections, details,

technical standards. Higher quality results, lower costs. On the other side prefabrication is seen as a less creative architecture, giving the product an overall lower value. Architects pride them selves on individuality and prefabrication takes that away with its mass production. Repetitiveness of industrialised parts is looked at with scepticism and as something lacking quality. Prefabricated building is associated with grid planing, boxed orthogonal shapes. The projects analysed in this thesis paper have been chosen to show that this is not entirely true and that despite grid planning, and mass production of parts, the projects can reach very different results in all architectural aspects (visual, functional, technical...etc)

Building systems have come a long way, and there is a long road ahead. The logistics of building systems and the development of materials and building components have fol-

lowed the progression of the building industry and shaped the design of homes, offices and cities built today.

The material quality available today and performance have reached a very high level. The production methods have reached a very efficient level. The future of building does not lie in the new improvements but instead, attention must be turned towards the innovative systems that will allow for a more energy efficient final product.

Architects are becoming aware of this, and are forced to consider, from the beginning of projects design phase, the need for conservation of the earth's natural resources and the need to plan our built environment in an intelligent and conscious way.

The idea behind using elements that are systematised, means that they can be produced

by different companies and that their system can be used in other countries with local companies. The goal is to find a universal system that is adaptable and flexible in order to accommodate different individual and global needs but without hampering the beauty of design, the aesthetics and originality that is always asked for.

Advantages of prefabrication

- Defined time lines, planning steps and building sequences
- Grid and modular arrangements
- Monitored and certified production
- Batch production and manufacture for storage
- Design of joints
- Restrictions regarding transport
- Short erection times
- High efficiency
- Fast construction speed
- High quality control



Fig.10: Transporting modules

- High precision
- Reduction of construction time on site
- Optimum working conditions (Production regardless of the weather)
- Economical use of materials
- Cost certainty
- Cost savings
- Low noise and dust pollution on site
- Minimized errors
- Use of computer aided design
- Use of computer aided manufacturing

Issues in prefabrication:

- Problematic of Transporting bulky elements (cost issues, air pollution, noise levels)
- The importance of coordination between design, fabrication and assembly
- Negative assumption that prefabricated systems are less creative.

Categorization based on production

a)flat-pack method

This is the do-it-yourself house kit. Ikea concept is an example in the small scale production. The precut flat panels are prebuilt in the factory, then compactly stacked together and transported to the location. They are then easily assembled on site. In Japan and Sweden 90 % of housing is prefab.²⁶

b)modular building

Modules are three dimensional independent units or partially complete sections. They can be repeated and connected to each other extending the space. Modular building is a more complete form of prefabrication than flat-pack method and includes completely equipped bathrooms or kitchens. The biggest advantage is that once delivered the system part is ready for use. The modules are often parts of plug and play systems where for example a bathroom just needs to

²⁶ Knaack U.; Prefabricated Systems: Principles of Construction; Birkhauser; Basel; 2012; pp 47

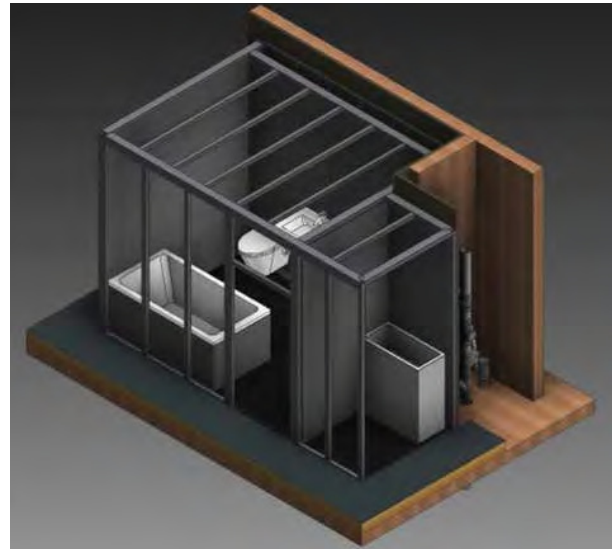

Fig.11: Prefabricated bathroom

be connected to power and water and is finished. The biggest disadvantage is the transportation of such a module. Also the on site placement is usually done by cranes and can pose problems as the modules might be exposed to forces different to what they were built to sustain.²⁷

Systems and their components

A system is a structure of elements that form a whole.

Systems can be divided into:

- Primary systems (structural system)
- Secondary systems (envelope)
- Modules (windows, doors, stairs, roof systems, facade modules)
- Elements (bricks, window frames, roof beams)
- Connections
- Technical elements (building services)

²⁷ Knaack U; Prefabricated Systems: Principles of Construction; Birkhauser; Basel; 2012; pp 48-49

A structural frame of the building is a primary system. It distributes the loads throughout the building. Parts of structural frame can either be load bearing only or can also have a function as space dividers. Building's envelope as a secondary system regulates the inside and outside such as temperature and the moisture. Partition walls are considered finishing elements. Both primary and secondary systems are made up of modules. Modules are elements assembled together by connectors. Some connections are done off site, some are assembled on site. The biggest challenge in prefab is designing connection systems that are simple to manufacture and can be assembled fast. It is the connectors that are responsible for not only the assembly of a prefabricated system but also it's future in terms of flexibility and possibility of reassembly and reuse as well as disassembly and options for recycling.

The components of a building can be categorised into basic forms: point, line, plane and volume form. The connections that correspond usually follow the form of the parts that they are connecting and are either nodal, linear or planar. The connectors also vary in intention and function and can be stiff, hinged, waterproof, airtight and flexible meaning that they can be made out of a number of materials (steel, aluminium, wood, glue). Technical elements include heating, ventilation, sanitary fittings, electrical units.²⁸

28 Knaack; 2012; pp 98-104



Fig.12: Assembly process

Chapter 4: building systems in timber high-rise

Introduction

The basic timber systems include:

- Log construction
- Timber-frame construction
- Balloon and platform frame
- Panel construction
- Frame construction
- Solid timber construction

Log and timber frame construction were commonly used in Europe throughout history, while balloon and platform frame construction were common in England and USA. Today, the importance has to be stressed on the difference between Light-Frame and heavy timber frame construction and especially the development of heavy timber construction with wood engineered materials that started in the 1990's.

While Light-frame is still used in low-rise to mid-rise building (up to 6 stories) heavy tim-

ber constructions are increasingly being used for mid- to high-rise building. The primary difference between the construction types is the section size of the timber members used in construction. "Although there is currently no universally accepted definition of "light" and "heavy" timber, timber can be considered as heavy where its minimum dimension of solid wood exceeds approximately 80 mm"²⁹

Light-frame timber construction is generally made up of a greater number of smaller elements. An example are frames that are made up of stud elements which are then enclosed within cladding to form a wall or a floor.

In comparison, heavy-timber construction is composed of fewer elements that are considerably larger in size. Heavy timber constructions enable longer spans, bigger open floor areas and taller constructions (than light frame constructions).

²⁹ Buchanan, A., Structural Design for Fire Safety. John Wiley and Sons, West Sussex, UK, 2001. retrieved from <http://magazine.sspe.org/content/high-rise-timber-buildings>; 12.2.2015

Current timber high-rise building systems can be divided into linear supported and point supported systems. In either case, engineered wood products are the main material used. It is the developments of the timber materials and processing techniques that have inspired the new high-rise systems. Solid sawn timber sections can be included but the engineered products offer greater strength.

A construction may be considered as a timber construction when its timber content is over 50% of the load-bearing system.³⁰

Choosing a building system depends on several factors: space, function, location, design, material. Also it is to be noted that the high-rise timber constructions are limited by the building regulations which differ depending on the country.

Many countries are still unaware of the cur-

rent possibilities of Mass Timber construction in comparison to conventional construction and it is exactly the appearance of timber high-rise project that is slowly causing the building codes to change.

³⁰ Kolb; 2008; pp: 39

Linear supported

This type of construction consists of solid timber panels as the primary structural elements. The loads are divided along linear elements (walls) and transferred from the roofs and the floors to the foundation. The advantage of the linear supported structures is that the load is distributed more evenly resulting in lower loading actions on the singular building components. Depending on the design the components can also carry out other functions such as bracing the structure, enclosure, space division.

Currently, the preferred material for the panel system is the wood engineered product referred to as cross laminated timber (CLT) and the system itself takes a name after it and is now known as CLT system.

Point supported

This type of construction concentrates the loading actions into points and then transfer them further to the foundation. Within these systems there is a clear division between load bearing and enclosing elements of a building. Typically, columns are positioned on a grid system and they carry the loads from the beams down to the foundation. Timber used in post and beam construction systems can include traditional solid sawn timber and contemporary engineered product such as glue-laminated wood, laminated veneer timber and cross laminated timber. The preferred material in high-rise timber constructions is Glulam.

There are combinations that use steel and concrete reinforced load bearing structure and interior timber walls. Intelligent construction and intelligent choice of materials adds up to quality architecture . We are look-

ing for a synthesis between parts.

Most buildings, however, are constructed with hybrid solutions for which linear and point supported systems are used as a basic idea. Regardless of the choice of system, all current timber high-rise buildings have been built on a concrete foundation. Depending on the location the concrete foundation may be chosen because of the need for a lighter construction because of poor underground terrain, and/or to provide extra stability and/or to protect from termites, etc. When the foundation is set in place, firstly the complete floor plan needs to be drawn (usually with a chalk) on the concrete marking all the measurements, carefully down to the last millimetre. Mounting points, fastening bracket and positioning strips are installed on to the foundation making it ready for the timber construction to be placed. Fastening brackets are usually manufactured as steel plates. In KLH

systems the distance between the brackets is usually between 100 and 150 cm. There is also a need for a horizontal moisture sealant.

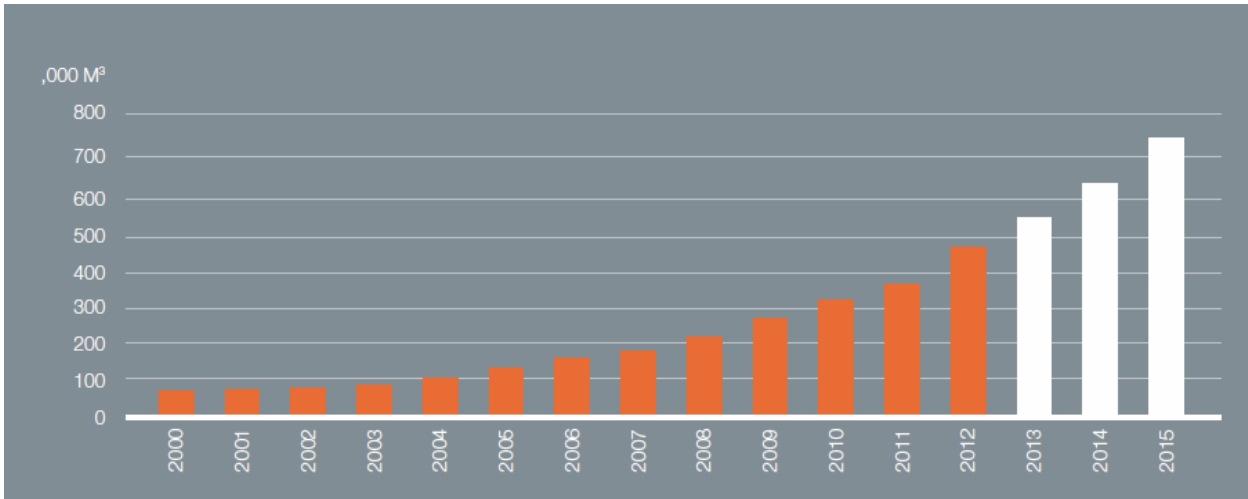

Fig.13: Growth of CLT usage in Europe

CLT panels

CLT is increasingly used in Europe as an alternative to steel and concrete. It was first used in Switzerland, Germany and Austria. Recently the panels have been adopted by Canada and New Zealand. The market leader at the moment is the KLH company from Austria. Apart from the local projects they also transport their product internationally. The currently highest timber building in the world (Forte, 32.17m), built in Melbourne, Australia also used their products.

CLT panel elements are prefabricated and then delivered, usually as flat pack systems to the site. The thickness of the elements is determined by calculating the loads that are to be carried and the critical buckling length. Usually, the thickness varies from 50 to 500 mm depending on manufacturer. CLT panels produce planar load bearing elements that can carry loads in both directions. There is

however a distinction between primary and secondary load-carrying direction. The system is not restricted by module or grid dimensions. However, attention is taken in design process in vertically aligning vertical load bearing elements. CLT panels correspond to a floor by floor building erection. This means that once the construction of a floor is finished the finishing touches can already begin without having to wait for all the other floors to be finished, shortening the overall needed time for a completion of the building. Also there is no need for a temporary roof to shield the construction from the outside weather influences.

In case of KLH company, CLT panels are generally produced out of spruce while other types of wood are available on request.

The size of their elements range within:

Length: 8.50m - 16.50m

Width: 2.25m - 2.95m

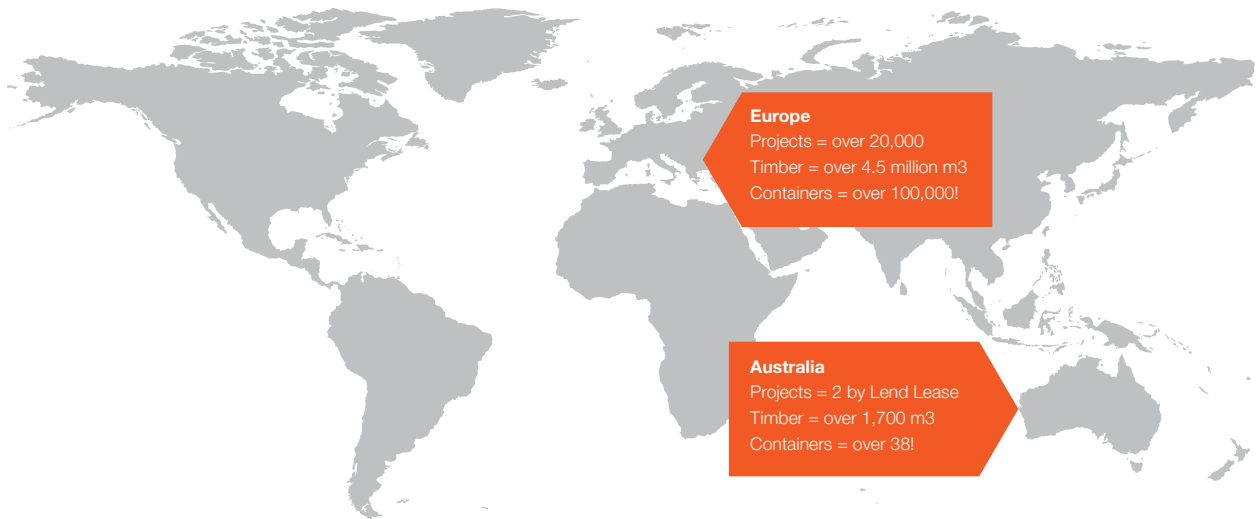

Fig.14: CLT world potential

Thickness: 0.10 – 0.50m³¹

Once the foundation is in place and the mounting points have been placed, CLT panels can be lifted into place. Temporary supporting struts may be placed as assistance until the whole structure is constructed.

CLT panels may arrive on site with pre-installed lifting strops. Once a panel is in place, the strops should be rolled up, put inside the anchor hole and then taped over. This enables the building to be reconstructed in the future. Depending on the manufacturer, tighteners may be used to insure insure a tight fitting between timber elements. The opening for windows and doors are precut in the factories and reduce the on site building time.

CLT panels that are perpendicular to each other (walls to floors) are connected using

standard fasteners: e.g. screws, brackets, stud anchors (for transition into concrete). Also sealing tapes are used to make the construction airtight. KLH also use elastomer supports to improve sound insulation.

Possible connection techniques :

Fig.17 shows 3 layer CLT board connections. CLT panels usually have 5–7 layers in high-rise building. However the principle is the same.

- Wall to base connections:

CLT boards can be installed on dry or wet mortar and over a sill plate with a joint-sealing tape.³²

- Wall to wall connections:

CLT boards should preferably have a full storey height, however both vertical and horizontal connections are possible.³³

³¹ KLH, Feb 2013; pp:06

³² KLH; Component catalogue for cross laminated timber structures; KLH Massivholz GmbH, Jan 2012; pp:4

³³ KLH; Jan 2012; pp:6



Fig.15: Glulam assembly, joint fastening



Fig.16: CLT assembly, joint fastening

- Horizontal wall joints (usually used in floors/ceilings) are constructed with the use of so called "butt boards". In the case of internal "butt boards" their minimal size is 27x80mm. The butt boards can also be placed externally.

- Vertical wall connections are also performed with the use of butt boards. Another way of connecting the floors is using a simple pre cut "lap joint"

- Corner joint:

The walls are connected by joint-sealing tape on the inside of the joint, and can additionally be sealed on the outside of the joint with a suitable adhesive tape. Also screw connection may be added: either at 90° angle or slanted.³⁴

use the least number of material possible. A wood only construction is most ecologically friendly, however this is not the only criteria and each option comes with its positive and negative attributes.

When considering the entire life cycle of a building, and its potential for reuse, reconstruction or deconstruction it is preferable to

³⁴ KLH; Jan 2012; pp:18

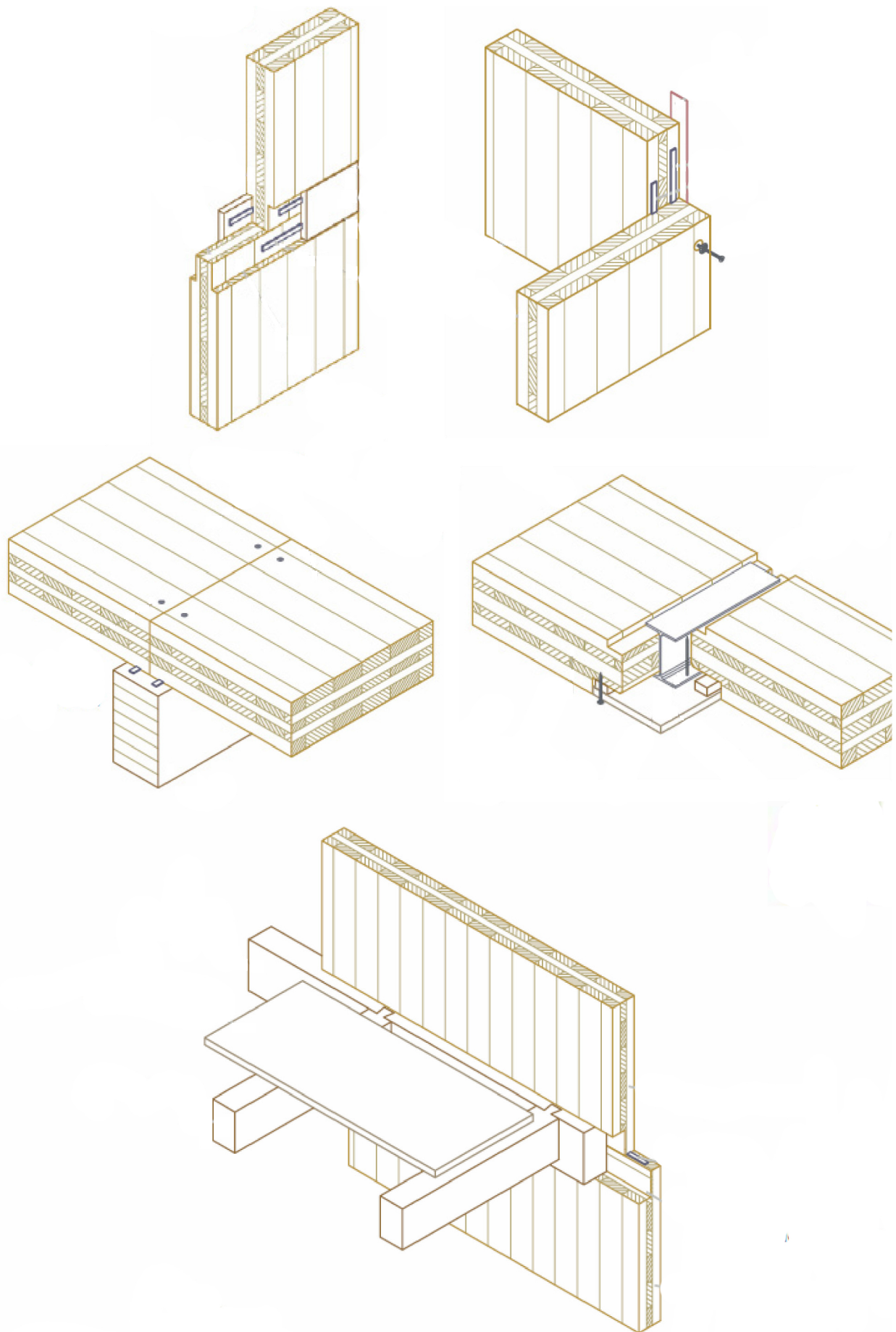

Fig.17: Possible connections



Fig.18: Interlocking CLT principle



Fig.19: Wall composed entirely of timber products; Wood-cube project , IBA, 2013

Future potentials

Interlocking CLT (ICLT) is a recent innovation still being developed. The ICLT construction idea came from Kip Apostol of Euclid Timber Frames. The reason is the striving for an even more ecologically friendly solution. Without adhesives the ICLT would be easier for deconstruction, recycle and reuse. Interlocking CLT is being designed to not use glue adhesives or fasteners to bind the layers together but instead focuses on using the method of dovetailed boards. The complex board joints that are designed to interlock are designed using the computer numerical control (CNC) equipment and cutting methods. The panels are milled with the joints and then the panels are connected like a puzzle. Interlocking cross laminated timber panels are still in the development phase.³⁵ "We've done structural testing on three- and five-layer ICLT panels

and have already built our first structures from them," says Ryan Smith, director of the Integrated Technology in Architecture Centre at the University of Utah, USA.³⁶

³⁵ University of Utah, College of Architecture + Planning; Interlocking CLT by Euclid Timber; retrieved from: <http://itac.utah.edu/ICLT.html>; 12.2.2015

³⁶ Ryan Smith; Wasted Wood Sees New Life; 4.6.2012; retrieved from <https://www.youtube.com/watch?v=f0bWytzMX08#t=118>, 12.2.2015



Fig.20: Glulam system by Shigeru Ban

Glulam load bearing elements

Glulam columns are load bearing elements. They are used as primary structural elements: columns and beams, and are placed on a wide regular grid. With this method internal and external walls (and facades) can be constructed separately. This allows for a free floor plan and large facade openings. Also by being on the inside of the building the load bearing system is protected from weather and can be left exposed internally. The primary structure forms a frame and carries the secondary structure and its loads. Both primary and secondary structures are prefabricated. Floors form a secondary system and are suspended on the primary column system. Since the envelope is not connected to the primary column system it can be constructed without joints or seems. It is a very favourable system with investors, because of its flexibility and the fact that it can be adapted to suit individual requirements.

The columns can either span over a single floor height as is the case in the Life Cycle Tower building in Austria, or can span the entire height of the building as it can be seen in Tamedia building in Switzerland. In this case, attention should be paid to the protection of the construction from the weather and usually a temporary roof is constructed.

The connectors and fasteners used sometimes remain visible, but concealed steel components inserted into the timber are preferred. Occasionally even true wood joints are used (Tamedia building, Switzerland)

Most commonly used Glulam has classification strength grade GL24h, appearance class N (normal), or I (industrial).

To achieve the same strength as a steel beam, a Glulam beam is typically much larger; This results in large amount of ceiling void space in comparison to steel.

Column spacing

From a structural side it is not the columns themselves that limit the spacing, as timber has high efficiency parallel to the grain and can carry high loads. The limitations depend on the buckling length and joint detail (where the load acts perpendicular to the grain).

Common spacing is:

- 2.5x2.5m
- 2.5x5.0m
- 5.0x5.0m
- 8.5x7.5m
- 8.5x10m

Frame construction

- Compound columns and beams
- Columns and over sailing beams
- Beams and continuous columns
- Forked columns

Grid

Proven grid dimensions for frame construction in timber include:

- 1250x1250
- 2500x2500
- 5000x5000
- 6250x6250
- 7500x7500

These dimensions are most likely to complement the standard sheeting and cladding material sizes.

Constructional aspects of the grid design:

- The construction and limitations of joints.
- The spacing of joints, rafters and columns in the secondary structure
- Format of floor, wall and roof elements
- Formats of sheeting and cladding material
- Dimensions of doors and windows.

Life Cycle Tower building in Austria, Dornbirn, uses double Glulam columns (hinged columns) as a primary system. The grid spacing measures 1.25m, 1.35m and 1.5m. Maximal floor span is 9.45m.

Hybrid systems

The biggest achievements can be expected in hybrid systems. It cannot be expected that one newly engineered material or one system will be able to fulfil all requirements in terms of energy neutral building while considering the complete Life Cycle of a building inclusive the end of life phase whether the planned action is disassembly, reuse, down-cycling or recycling. It is unrealistic to expect a perfect 100% outcome. The importance however is, to strive for it, in order to come as close as possible. Hybrid solutions aim to bring out the best traits of the individual systems within the hybrid system, while lowering the negative side effects of each.

A realised example of a hybrid high-rise timber construction building is currently under construction in Norway. The system is a combination of prefabricated 3D modules, a CLT core, and Glulam beams as the external

load bearing system. Detailed explanation of the system is covered in the Case Studies chapter.

Damage control

In every building system, no matter how small, the danger of the building collapsing is a possibility. The way to minimise the damage is to be able to control the damage. By combining the advantages of different materials, systems can be optimised for particular situations. For example, there have been innovations related to danger from earthquakes. "When a building sways on a movement there will be damage, but the goal is to control it in order to prevent the complete collapse. It's also not good enough to just save lives, you have to design buildings so that you also save property." Low damage system, developed in the first place for concrete buildings, has proven to perform even better in timber constructions. Press Lam is a name

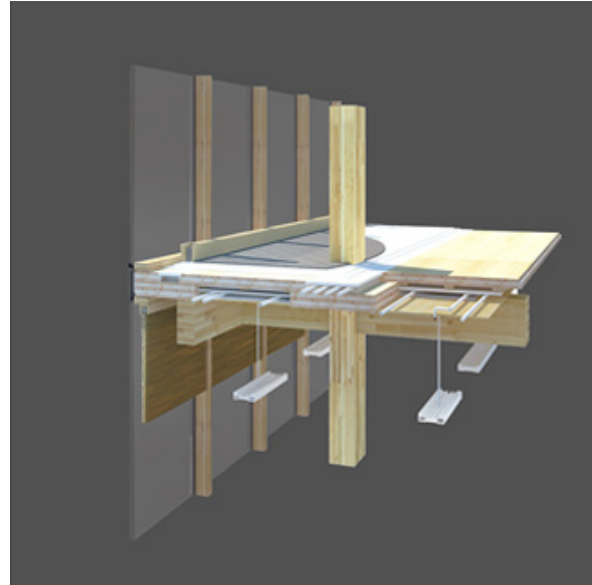

Fig.21: Prefabricated hybrid floor

for prestressed laminated timber. It contains prefabricated beams and columns that have a cavity in the centre so that steel rods can be threaded in and stressed up and then the elements are anchored in. The tendons can be straight or draped (using a deviator).³⁷ First building to use this system was NMIT Arts & Media Building in New Zealand in 2010.

Floors

The post and beam form of construction is often used in combination with steel and reinforced concrete. We can see that on the example of Cree's Life Cycle Tower that Glulam posts support hybrid floor panels made from Glulam beams embedded in reinforced concrete. The Glulam adds strength for little weight, while the concrete gives fire protection and sound insulation.

"Experience shows that timber suspended floors spanning more than 5.5 m require a greater structural depth than reinforced concrete floors. Compared to concrete, a timber floor is 1 to 1.3 times deeper for spans of 5 or 6 m, or 1 to 1.5 times deeper in the case of heavier loads and longer spans."³⁸ There are, however, timber building systems in which a smaller structural depth is possible: solid timber floors, timber-concrete composite floors, and hollow-box systems. Voids are useful for routing pipes and cables, and for accommodating layers of insulation. In fact, deeper suspended floor structures result in simpler and more economic constructions. It is important that an adequate depth is planned from the beginning of the design process.

Depending on the plan layout and the timber building system chosen, the floors can be

³⁷ Buchanan A.; Resilient Seismic Design in Multi-Story Wood Buildings; 11.8.2014; retrieved from: <https://www.youtube.com/watch?v=NiE4eWf89xo>; 12.2.2015

³⁸ Kolb; 2008; pp183

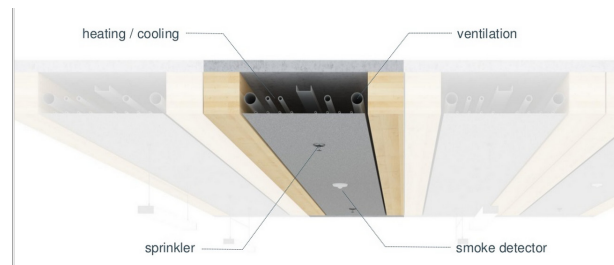

Fig.22: Life Cycle Tower, installations

positioned level with the beam construction or suspended below.

Installations:

The space for the installations is prefabricated using milling machines. For electrical installations, plumbing, heating, ventilation and similar building services it is either necessary to cut chases in the solid elements or add a framework of battens (usual size: 40 to 60mm). KLH recommends that the maximum depth can reach 4/5 of the panel thickness.³⁹ Many suppliers today design complete installation systems as Plug and play systems, and then make use of separate service ducts for the building services which enables re-fitting or modifications at anytime.

Current system heights

The projects that have been realised until now suggest following possibilities regarding the height of the building and the applicable construction system:

- Up to 12 stories : Glulam columns (Life Cycle Tower in Austria, Shigeru Ban building in Switzerland, Wood Innovation and Design Centre in Canada)
- Up to 20 stories: CLT panels with internal load bearing functions (Forte building in Australia)
- Up to 30 stories : load bearing exterior and interior mix. (Treet building in Norway)

Michael Green Architects from Canada have conducted a study: Tall Wood (2012), where different structural possibilities are presented for buildings from 12 to 30 storeys in height. They have developed the FFTT system (Finding the Forest Through the Trees). FFTT is available for free under a Creative

³⁹ KLH; Component catalogue for crosslaminated timber structures; KLH Massivholz GmbH Version: 01; 2011; pp:20

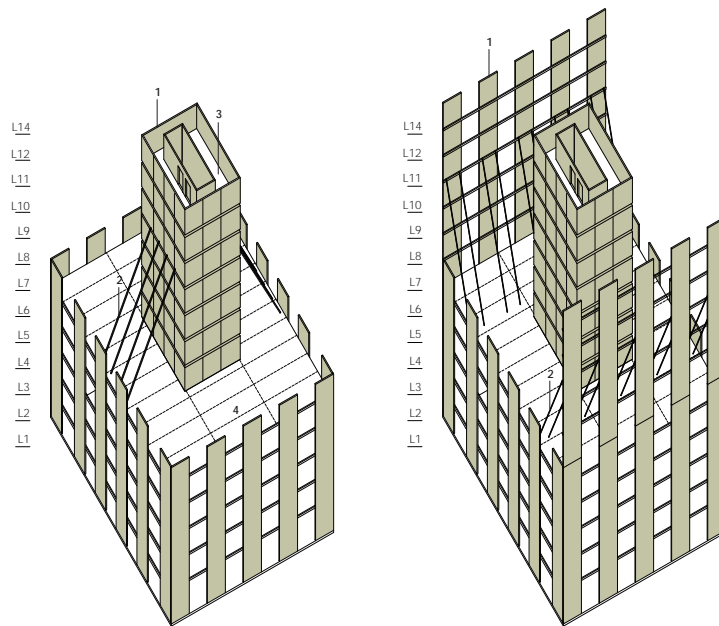

Fig.23: Tilt-up assembly system by Michael Green Architect

Commons license. The system includes suggested materials, cost analyses, structural, acoustic and fire performance data, and full floor plans and cross-sections.⁴⁰

Their study is a long term plan and it is team work. Timber buildings are nothing new in Canada, and they can be seen as experts when it comes to the wood materials themselves. However their experience in prefabricated systems for high-rise in timber is still low. They are very much looking at the developments in Austria, and CREE in particular for solutions, suggestions, ideas.. It is exactly though this collaboration of architects from all around the world that we can hope to come up with even better solutions and expand in this field.

FFTT is a unique tilt-up system. Mass Timber panels are used for floors, walls and the

⁴⁰ <http://eandt.theiet.org/magazine/2012/09/wood-goes-high-rise.cfm>

building core with engineered wood columns (up to 12 storeys) and steel beams and ledger beams (12 storeys and up) integrated into the Mass Timber panels supporting floors. The introduction of steel allows for the 'weak beam' solution and great flexibility for the system to achieve heights with a predominantly all-wood solution.

The FFTT System proposes a following system solution:

For a maximal 12 storey height:

Wood core walls and Glulam perimeter columns are the supporting structure. Interior walls are not load bearing allowing for a flexible floor plan layout and flexible facade design with the ability to support an entire curtain wall envelope. Interior modifications are easily possible for changes in occupancy or use.

- For maximal 20 storey height:

a) Compared to previous system, additional

interior structural walls are introduced. The absence of exterior structural walls, allows flexibility in the design of facade and possible curtain wall construction. In terms of interior planning, the introduction of interior load bearing walls diminishes some flexibility in floor plan layout making this structure more suitable for a residential application.

b) As an alternative, a complete structure can be achieved with CLT panels. However, this option closes up the facade as it uses external load bearing walls instead of columns.

- For heights of up to 30 storeys: Structural core, and internal as well as external load bearing CLT panels would be needed for support. In comparison to the previous solution this one has the least flexibility.

Joints:

An overall cost of a load bearing system is influenced by the number of joints that are needed. Lowering the number of joints lowers the price. Connectors themselves also play an important part in overall structural strength. Connections transfer loads between structural elements. Steel connections are often used with wood, representing a case where connector itself is stronger than the element. Steel connections are relatively small, require little labour. Wood connections are in comparison bigger and more labour intensive.

The connection between columns and beams can be :

- Close tolerance bolts and screws
- Shear-plate and split-ring connectors
- Notched joints
- Side plates
- Welded steel components



Fig.24: FFTT Option 1

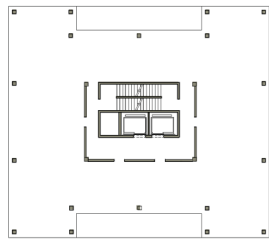

Fig.25: FFTT Option 2

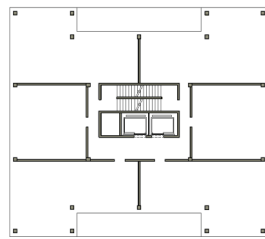

Fig.26: FFTT Option 3

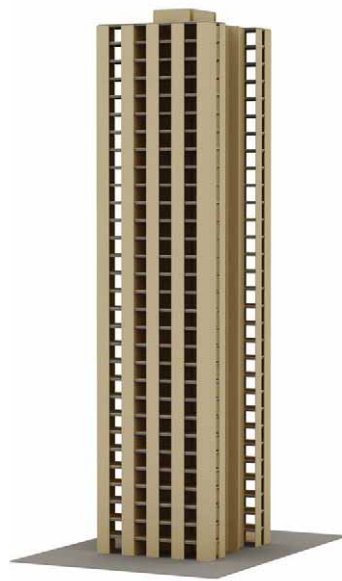
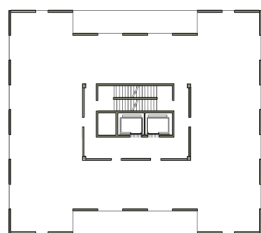
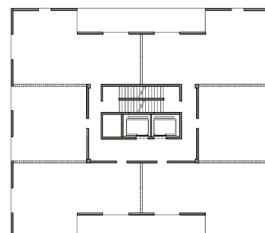

Fig.27: FFTT Option 4



-
- Mortise and tenon joint
 - Sheet steel components
 - Bonded threaded bars
 - Wood screws (for tensile forces)⁴¹

The new challenges that architecture is facing today when it comes to prefabricated buildings is to improve the systems in order to fulfil the requirements for sustainable building. A complete life cycle of a system needs to be considered and this means not only the way to construct it but also how to deconstruct it.

Deconstruction or disassembly represents the most effective way to preserve the embodied energy of the materials that make up the built environment. To facilitate the recycling of materials, buildings need to be designed to enable the dismantling and the reuse of elements and it is architects responsibility to take action by including the method of Design for Deconstruction in the design process itself and this needs to be done from the very begin of the project.

To initiate the awareness of the Design for Deconstruction (DfD), the main ideas need to be presented and understood.

- The technologies should be used to it's full potential in order to build while creating minimum waste in the first place.
- The buildings need to be adaptable, and able to change together with users' needs.
- The buildings must have the ability to be dismantled into their components or as a

41 Kolb, 2008, pp95



Fig.28: Building layers scheme by Lukas Lang

Chapter 5: Design for Disassembly

whole to be re-assembled, re-used or recycled.

Disassembly technique is a new discipline within the field of architectural engineering practice and theory. It should be pointed out that it is absolutely not part of the current daily routine among professional architects to plan for and to explain how buildings are demolished, or how materials can be reused and recycled respectively. The large quantities of construction and demolition waste, produced from construction related activity, are resulting in a significant burden on society and that is why this factor should be considered.

General principles for DfD

The following general principles should be followed already during design process in order to maximize the possibility of reuse of elements or recycling of materials:

- The building needs to be documented in detail with as-built drawings, photographs of hidden components, connections and material descriptions. A list of building elements with their life span and potential for reuse should be added.⁴² Labelling of the elements by a bar code, stamp or RFID microchip speeds up the identification at element level and is optionally to be considered (information stored can include: material type, characteristic properties, origin, place, time, dimensions, toxic risks, etc.)⁴³
- Instructions for disassembly should be added in the building documentation. The deconstruction steps and aids should be simple.

⁴² Crowther P. 2005. Design for disassembly: Themes and principles. RAIA/BDP Environment Design Guide, Aug 2005; pp5-7; retrieved from <http://eprints.qut.edu.au/2888/1/Crowther-RAIA-2005.PDF>, 15.2.2015

⁴³ Hechler O.; Life-time structural engineering: Design for durability, life-cycle performance, maintenance and deconstruction. Design for deconstruction. Faculty for the Built Environment, University of Malta, Malta. 2011. pp: 343; retrieved from http://iftc.civil.uminho.pt/C25_Final_Outcome_Volume_2_2011.pdf; 12.2.2015

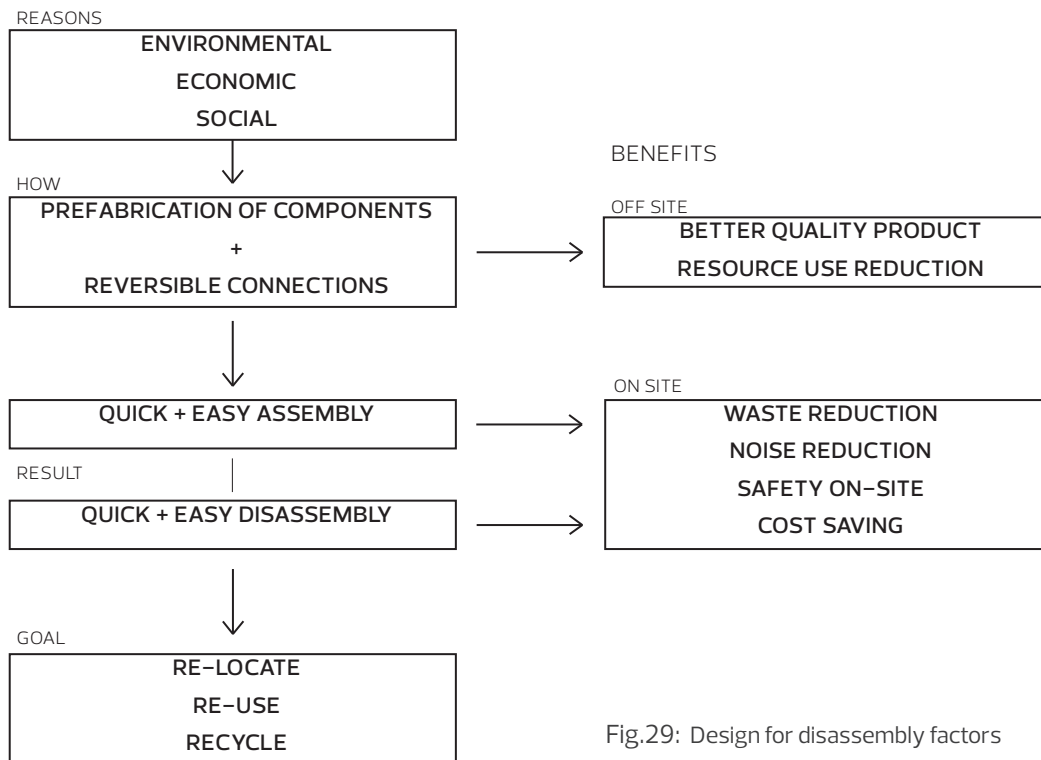

Fig.29: Design for disassembly factors

- Layering during design is recommended. This means having a strategy in place for handling different life cycles of separate building elements. It accounts for differences in expected lifetime for⁴⁴:

- Structure (30 – 300 years life expectation; typically 60 years for buildings)
- Skin (cladding, roofing: ca. 20 years),
- Services (ca. 7-15 years)
- Space plan (change each 3 years in commercial buildings, every 30 years in domestic buildings)
- Stuff (furniture and non-attached space elements: may change daily to monthly)

The layers in a building should be technically separated to allow for changes with a minimal use of resources and cost. A recycling hierarchy should be accounted for in layering in such a way that independent exchange of

⁴⁴ Durmisevic E.; Transformable building structures: Design for disassembly as a way to introduce sustainable engineering to building design and construction. Ph.D. Thesis. Delft Technical University; 2006; pp:103

building parts according to life cycles is enabled.

- Plaster or screed should not be foreseen
- On the level of service integrations, concealed wires should be avoided; services in channels (e.g. integrated in facade or slabs) are recommended

Principles for the choice of materials

With the right choice of materials the reuse/ recycling rate can be significantly stimulated. Following requirements illustrate a step in right direction:

- Use recycled and recyclable materials: to allow for all levels of the recycling hierarchy; increased use of recycled materials will encourage industry and government to develop technologies for recycling and to create larger support networks and future markets.⁴⁵

- In general, limited number of materials

⁴⁵ Crowther; 2005; pp7

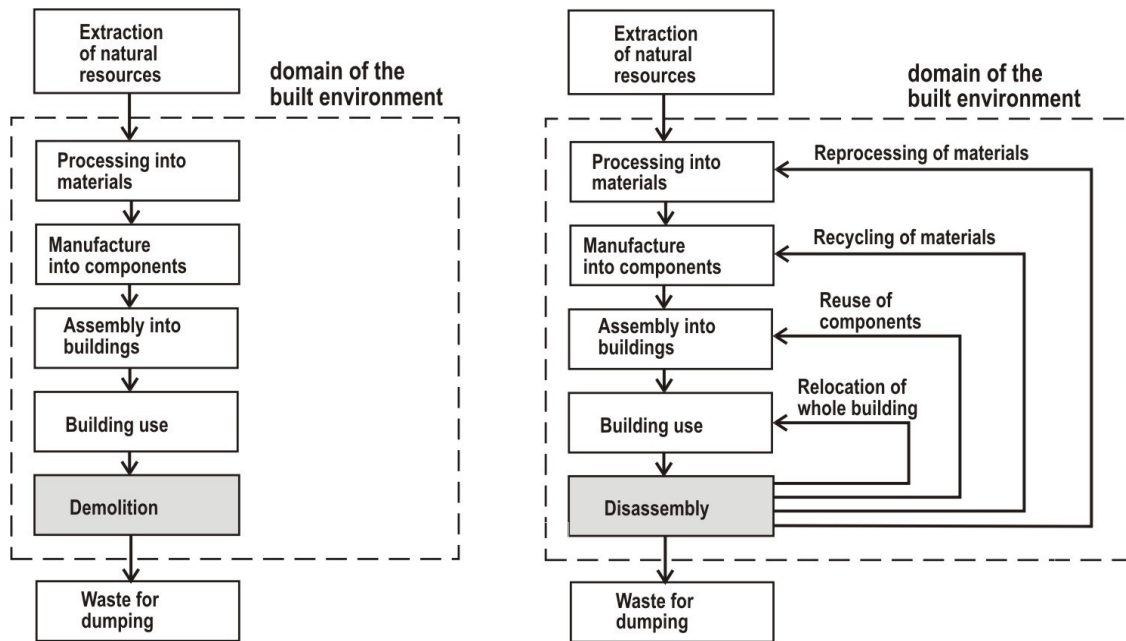

Fig.30: End-of-life scenario in a building;

leads to higher reuse/recycle rates – this will simplify the process of sorting during disassembly, reduce transport to different recycling locations and result in greater quantities of each material.⁴⁶

- Avoid paintings, fire protection spray or intumescent paints to get back clean material⁴⁷
- Durable materials and components with good tolerances are to be preferred⁴⁸
- The use of non-recyclable materials like thermal insulation (glass wool, polystyrene), hard plaster, light-weight materials with low recycling possibilities should be avoided.
- Avoid toxic and hazardous materials. This will reduce the potential for contaminating materials that are being sorted for recycling, and will reduce the potential for health risks that might otherwise discourage disassembly.

46 Crowther; 2005, pp:7
 47 Crowther; 2005, pp:7
 48 Hechler; 2011, pp: 345

Principles for the structural design for DfD

In general, the structural system of a building comprises over 50% of the building weight and, traditionally, has the lowest potential for reuse. Thus by respecting the following principles in the structural design will increase the potential for reuse/recycling:

- Use a standard column grid and inter-storey height.⁴⁹
- Use as wide of structural grid as possible to maximize the non-structural wall elements.⁵⁰ Also, to allow for flexibility of reuse, e.g. by trimming to a new length.
- Use prefabricated subassemblies and a system of mass production to reduce site work and allow greater control over component quality and conformity.⁵¹
- Use an open building system where parts of the building are more freely interchangeable

49 Hechler; 2011, pp: 345
 50 Guy B., Ciarimboli N.; Design for Disassembly in the built environment; Seattle; 2005; pp: 8; retrieved from <http://www.life-cyclebuilding.org/docs/DfDseattle.pdf>; 12.2.2015
 51 Crowther; 2005, pp:7

and less unique to one application. This will allow alterations in the building layout through relocation of component without significant modification.⁵²

- Minimize the number of different types of components for simplification of sorting, reduction of different disassembly procedures to be undertaken and for making recycling and reuse more attractive due to greater numbers of fewer components.⁵³

- Roof structures are generally suitable for reuse after deconstruction if made of truss or framework systems. After dismantling, they may be reassembled in their original configuration or in alternative layout.

- Design modular structures. The use of dimensionally and functionally compatible components and materials is supported.

- Partial deconstruction process should be taken into account during design of the structure.

⁵² Crowther; 2005, pp:7
⁵³ Crowther; 2005, pp:7

- The smaller and less complicated the elements are, the better their potential for reuse. Further handling becomes easier during assembly, disassembly, transport, reprocessing, and re-assembly⁵⁴

Principles for foundation design for DfD

The foundations are the basis of any construction. For their design for deconstruction the following should be considered⁵⁵:

- Precast concrete pad foundations or steel screw piles should be preferred for easy removal and reusing

- Steel and precast concrete driven piles can be used for deconstruction

- Sheet piles are commonly used as temporary retaining structures (a stock market for reused element already exists)

- Design foundations to allow for potential vertical expansion in lieu of demolition.

⁵⁴ Hechler; 2011; pp: 346
⁵⁵ Hechler; 2011; pp: 347-348

Life cycle assessment and DfD

The lifetime of structures is conditioned by market economy, sociopolitical constraints, popularity. At end of their life, buildings should be deconstructed.

The end-of-life scenario of a building can be separated into 3 sub-phases:

- Environmental impact of deconstruction activities (dust, noise, etc.),
- Re-use and recycling rates of materials,
- Environmental impact of re-processing of materials

The 3 sub-phases must be considered together. The ability to recycle waste only partially addresses the problem because the energy and resources that would be needed to carry out the transportation and re-processing must also be considered, and then the complete calculation must be taken into account.

Principles for connection design for DfD

A primary way to ensure easy deconstruction and increase the recycling/reuse rate is seen in appropriate design of connections. Further, connections are being responsible for design, fabrication and erection issues and thus, the necessity and pressure for an appropriate connection design becomes obvious. The following should be considered for designing the connectors:⁵⁶

- Connection of element should facilitate dismantling and mutual independency between the elements should be considered
 - Use of standard and reversible fixing should be considered such as bolted connections instead of welded joints for steel structures, tongue and groove or expansion sealant.
 - Connections as cast joints, glued fixation and elastic sealant should be avoided.
 - Timber structures may easily be

⁵⁶ Hechler ; 2011; pp: 345-347

disassembled if mechanical connections instead of glued joints are used. With regard to recycling, screws are to be preferred to nails, which may remain embedded in the timber during separation

- Less different types of bolts inside the system
- Easy and permanent access to connection should be guaranteed

Connectors and design for disassembly

Innovative CLT and Glulam connectors give new opportunities for faster assembly by having the connectors included into the panel. Examples include SHERPA and KNAPP systems. They allow easy disassembly and give opportunity of re-use of initial component with included connector.

1) Sherpa connection is best suited for post and beam construction and it has a wide connection range. As opposed to traditional connector, installation is faster and with less screws damaging the panels.

Connectors cover:

- Timber to timber connection
- Timber to concrete or steel connection
- CLT component connection

The Sherpa connector, developed by Vinzenz Harrer GmbH in cooperation with the Technical University Graz (Austria), can be used in

load-bearing timber to timber or timber to concrete or steel connections. It comprises of two aluminium pieces following the tongue and groove principle. Sherpa system allows for a safe force transfer in installation direction both opposite the installation direction and perpendicular to the installation direction. Tension and compression forces are also effortlessly handled.⁵⁷

- Pre-installation of connection elements are done at the plant by routing each timber element with CNC machine and inserting the aluminium connection elements. Components are transported to the construction site ready for assembly without use of additional tools.

- Connection range⁵⁸

- XS-M Series (5–40kN)

(Beam hanger for smaller wooden structures)

⁵⁷ SHERPA; Connection Systems; Company; retrieved from <http://en.sherpa-connector.com/company>; 12.2.2015

⁵⁸ SHERPA; Connection Systems; Products; retrieved from <http://en.sherpa-connector.com/products>; 12.2.2015



Fig.31: SHERPA connector

- L-XXL Series (30–300kN)
(Beam hanger for bigger wooden structures)
- M-XXL CS (Steel–Concrete)
(Beam hanger between wood and steel or concrete)
- CLT Connector (BSP wall connector)
Angle joints, T-joints and parallel joints.
- Power Base (Column Base)
Column base with zinc–nickel coating

- Installation

SHERPA connectors can either be screwed on, or mounted in such way that they remain invisible. For an invisible connection, it is necessary to mill the connector in, at either the main beam or the supporting beam. This can be done with the help of a manually operated router. Alternatively, it can be done with the help of a cutting centre and a CNC machine.

- Assembly is carried out by simple tongue and groove principle without use of additional tools. This quick and simple assembly also allows demountability without

damage.

- System advantages
- Fast installation – cost saving
- Standardized connectors
- Multifunctional in strength & application
- High degree of prefabrication
- Simple installation with standard tools
- Demountability of components without damage
- Reusability of entire elements
- Hidden connections

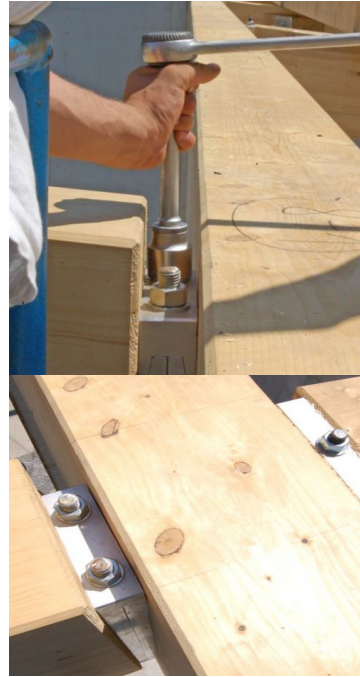

Fig.32: MEGANT connector

2) KNAPP is an Austrian company that specializes in developing high-quality, patented fastening systems. With more than 50 connecting systems KNAPP offers its customers a wide range of innovative efficient solutions such as furniture and interior design, wood-glass facades, timber-framing and prefabricated wall systems. All systems have in common the feature that when installed they are invisible, self-tightening and if needed can be disassembled.⁵⁹

- Connectors cover:
 - Timber to timber connection
 - Timber to concrete or steel connection
 - CLT component connection
 - Wood - glass facades
- Structural system:
 - Post&beam
 - Pre-manufactured timber walls
 - Portal frame system

⁵⁹ KNAPP; retrieved from http://www.knapp-verbinder.com/index.php?option=com_virtuemart&page=shop.browse&category_id=58&Itemid=198, 15.2.2015

- Types of connectors:

A) MEGANT⁶⁰

The heavy duty system for engineered connections up to 500 kN load range; standard sizes for up to 341 kN, custom solutions for up to 500 kN

- Installation possible from any direction
- Short hook-in; only 20 mm; parallel lowering of main / secondary beam not necessary
- Installation: reduced crane time through high degree of prefabrication
- Minimum required timber width only 100mm

- Assembly

Timber elements with incorporated connector are lifted in place, then threaded rods are inserted and nuts and washers tightened

⁶⁰ KNAPP; retrieved from <http://www.knapp-verbinder.com/microsites/en/megant.html>; 15.2.2015



Fig.33: RICON connector



Fig.34: GIGANT connector

B) RICON⁶¹

The connector for post/latch and header/joint connections for up to 28 kN

- Approved for eccentric loads up to 850kg glass load
- RICON is adjustable to compensate timber tolerances
- Wood to wood/ steel /concrete
- Flexible installation: from outside to inside or reverse
- Versatile: can be used for single and double connection
- Unique: possible for polygon facades
- Minimum required timber width only 50mm

C) GIGANT⁶²

The connector for main and secondary beam for up to 29,2 kN

- Highly loadable: Load resistance in four directions
- Self-tightening
- Fire resistance (DIN 4102-2) by 4 sided concealed mounting
- Optional locking clip secures against uplift
- Minimum required timber width : 60mm

Knapp has simpler production of connections than Sherpa, but not as broad use. It is also more suitable for lower buildings.

⁶¹ KNAPP; retrieved from http://www.knapp-verbinder.com/index.php?option=com_virtuemart&page=shop.browse&category_id=59&Itemid=198, 15.2.2015

⁶² KNAPP; retrieved from <http://www.koch.ch/katalog/uniDoc/Datenbl%C3%A4tter/94.074.0120/Knapp%20Gigant.pdf>; 15.2.2015

Chapter 6: Digital prefabrication

Development of engineered timber materials is closely connected with the developments in digital prefabrication. Once the timber panels are produced it is with the means of digital prefabrication that they are cut to size and shape that is required by the design.

“We've had a digital revolution, and we don't need to keep having it: we've won. What's coming now is the revolution in digital fabrication”⁶³.

Digital fabrication is a way of making products using digital data. It is a process that connects the digital and the physical world. It relies on computer driven machines that control the fabrication, either by cutting the material, bending it, welding, milling, or building the product. It is the integration of these two worlds that will enhance both, creating huge potential.

⁶³ Neil Gershenfeld, Unleash your creativity in a Fab Lab, at TED Conference: Feb 2007, retrieved from http://www.ted.com/talks/neil_gershenfeld_on_fab_labs/transcript?language=en; 2.2.2015

Rapid Prototyping is the process used to create prototypes in design process and Rapid Manufacturing to create the end product. Laser cutter, 3D printer and CNC milling machines are the currently most used machines used for digital fabrication. While 3d printers are used for smaller products, the CNC milling machines are already being used to cut and prefabricate Massive Timber products that are used in construction. The benefits of these machines is that because they are controlled by computers they are faster and more accurate to traditional hand controlled methods. The definition of computer driven machinery is quite broad: both in what the machines do (bending, cutting, welding, milling, printing...), on what scale (from printing on the Nano scale to complete buildings) and for what price (the machine's price tags range from tens of euros to several millions).

Computer aided Design (CAD) can be seen all around us. Computers and their various soft-

ware are being used in design, planning, virtual testing, calculations, etc.⁶⁴

"Every few generations, the fundamental means of production is transformed: steam, electricity, standardization, the assembly line, lean manufacturing, and now robotics. Sometimes this comes from management techniques, but the really powerful changes come from new tools. And there is no tool more powerful than the computer itself. Rather than just driving the modern factory, the computer is becoming the model for it."⁶⁵

The next step we are moving towards is Computer Aided Manufacturing (CAM). When considering Mass Timber panels that are fabricated using CNC machines it is the accuracy of the machines that allows for the construction joints to be produced precisely to the last

⁶⁴ Stoutjesdijk P.; Digital design & Digital fabrication for ultimate challenges; TU Delft; thesis; Jan 2013; pp20–30;

⁶⁵ Anderson, C.; Makers: the new industrial revolution. New York, Crown Business; 2012; pp141

millimetre which allows the material to perform up to its full potential. The cutting accuracy is within the range of of +/- 2 mm for a 1 m² size panel.⁶⁶ The versatile highly efficient timber connections allow for innovations in design. The newly engineered wood products also allow for more flexibility and diversity in system design.

Today, our industries no longer have to be a slave of mass production, repetition, and sameness. A great advantage of digital fabrication is that it does not depend on quantity to be cost-effective. Technologies like water jet-cutting, 3D printing and CNC-milling make it possible to achieve high quality and low-cost production without the need to produce in series.⁶⁷

"It is just as easy and cost effective for a CNC-milling machine to produce 1000 unique

⁶⁶ KLH; Feb 2013, pp:5

⁶⁷ Stoutjesdijk P.; 2013; pp27

objects as to produce 1000 identical ones." (Kolarevic 2003)⁶⁸

In relation to the 10% of architecture that architects are currently involved with, their role can change in multiple ways. In some of this 10% projects, like individual houses and small offices, it is likely that architects lose some control to nonprofessional designers. However, as functional as these tools can be, they will always remain just a tool, and never take over the process itself.⁶⁹

21st century innovations in architecture will not mean coming up with yet another never-been-built gimmick or conceptual experiment. Instead, innovation will focus on the process of designing and the process of making, embracing new technologies, new

cultural shifts and new challenges.⁷⁰

By some estimates, there is a potential for building construction to become 28–40% more efficient.⁷¹

68 Kolarevic, B.; *Designing and Manufacturing Architecture in the Digital Age*; pp.122; retrieved from <http://www.e-architekt.cz/digiarch/ecaade-01paper.pdf>; 15.2.2015;

69 Stoutjesdijk P.; 2013; pp27;

70 Stoutjesdijk P.; 2013; pp27;

71 Kolarevic B; *Digital Fabrication: Manufacturing Architecture in the Information Age*; ACADIA; 2001; pp274

Chapter 6: Case studies

Austria, Dornbirn, 2012

Building: The Life Cycle tower

- Facts

Height: 27m (8 floors)

Length: ca. 24m

Width: ca. 13m

Floor space: ca. 2500m² (brutto)

Volume: ca. 7400m³ (brutto)

Architect: Hermann Kaufmann

Client: Rhomberg Bau

Consulting engineer: Arup Group

Life Cycle Tower (LCT) is the first realised project based on the Life Cycle standardized system developed by CREE. The system has been developed with the aim of reaching the height of 100m (ca. 30 stories) with a timber construction.⁷² This has yet to be achieved. "We want to make buildings like car com-

panies make cars, or computer companies make computers, using an industrial process and a systems approach," says Nabih Tahan, an architect from CREE.

LCT is an office building with a ground floor being used for retail purposes. One of the standouts was the speed of the erection time. Once the base of the building was completed, the erection was performed floor by floor, each floor needing only 1 day to be completely erected and sealed from weather conditions. On-site erection was carried out by only 6 people at a time. In total construction (including prefabrication) began in September 2011 and was completed in September 2012.⁷³ The main feature of LCT is its exposed timber structure. It has been achieved with a hybrid construction system.

⁷² Cree Buildings; The Natural Change in Urban Architecture, Info brochure; pp: 7; retrieved from <http://www.creebuildings.com/files/CreeBrochure.pdf>; 6.2.2015

⁷³ Wood design & building; LCT ONE: winter 2012-13, pp:26; retrieved from http://www.creebuildings.com/files/130129Wood_Design_BuildingLCT_ONE.pdf; 6.2.2015



Fig.35: Life Cycle Tower, cross sections

- Base

Basement and ground floor are constructed in reinforced concrete and built on-site completely separate and previous to the rest of the building. Concrete was chosen in order to exclude any external impact from humidity, fire or insects. The floor slab above the ground floor is furnished with the mounting points ready for the timber system to be placed on it.

- Core

houses vertical circulation and mechanical utilities. According to the research and calculations performed by Cree the LCT system allows for the core to be constructed either in wood or concrete. The choice of material depends on regional building regulations, and in this project it lead to the choice of concrete as Austrian building code states that the circulation and service cores must be built from non-combustible materials. The central core

acts as a stiffening element within the LCT system. It provides stability by resisting lateral forces (wind loads, seismic loads, and loads provoked by the sloping site). Steel brackets are attached to the core to act as connectors and support for the horizontal slabs. Steel brackets were sized for a live load of 4kN/m^2 .⁷⁴

- Load bearing system:

The primary system consists of vertical and horizontal load bearing elements. Double Glulam columns (triple on corners) are the vertical elements. They are $0.24 \times 0.24\text{m}$ in size and positioned with 1.25m , 1.35m and 1.5m in between. The columns have a single floor height. There are 112 double columns and 21 triple columns (corners). Already in prefabrication process the columns are fitted with the floor/ceiling con-

⁷⁴ Tectonica; Tectonica Projects; Office Building in Dornbirn; pp:6-8; retrieved from <http://www.tectonica-online.com/projects/41t70/>; 6.2.2015



Fig.36: LCT assembly scheme

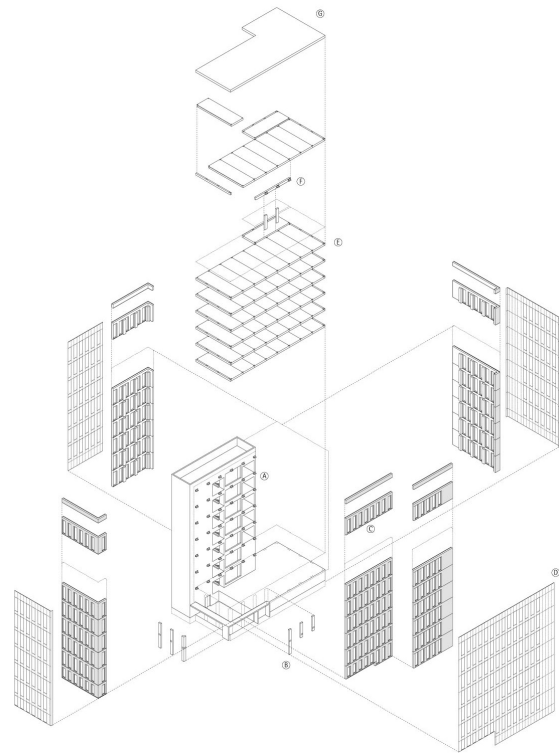

Fig.37: LCT axonometric display

nectors. Also as the columns are positioned on the external edge of the floor plan they are already in prefabrication connected to the outside wall panels and brought to the building site as one hybrid element: load bearing columns and non-load-bearing walls.

The horizontal load-bearing elements are prefabricated as timber concrete hybrid elements. Continuous layer of concrete that runs in the horizontal floor elements acts as a fire protection as it provides a break between the timber columns that span vertically.⁷⁵ They are connected to the core by steel bracket connections and rest connected to the Glulam columns. Floor slabs can have a maximal span up to 9.45m.⁷⁶ The wooden beams are laid into a steel framework of 8.1x2.7m; The distances in between are formed and con-

creted using a grouting technique.⁷⁷ The connection between concrete and laminated timber construction is achieved with screws and shear grooves.

The primary load-bearing system kept on the outside edge of the floor plan results in a flexible space division which compliments the multipurpose function of the building.

- Secondary system

Aluminium facade is a non-load-bearing element. Facade envelope is made up of prefabricated elements that are positioned on a grid measuring 2.70x10m.

Outside walls are in prefabrication attached to the double columns to create one component. On the interior side are sheathed OSB boards and exterior panels are composites of wood and cement binder. The windows are prefabricated as wood and aluminium com-

⁷⁵ Arup; Arup projects; Life Cycle Tower; retrieved from http://www.arup.com/Projects/LifeCycle_Tower/Details.aspx; 5.2.2015

⁷⁶ Cree Buildings; The Natural Change in Urban Architecture, Info brochure; pp: 15; retrieved from <http://www.creebuildings.com/files/CreeBrochure.pdf>; 6.2.2015

⁷⁷ Kaufmann Hermann; Projektdatenblatt: LifeCycle Tower - LCT ONE; pp: 4; http://www.hermann-kaufmann.at/pdfs/10_21.pdf

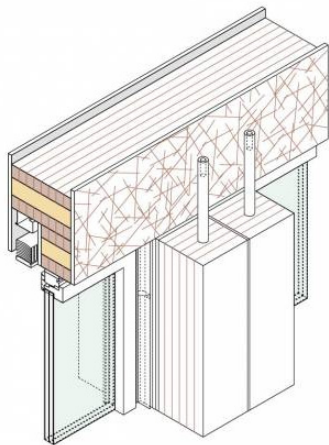

Fig.38: Prefabricated self-supporting facade panel with Glulam timber engaged columns.

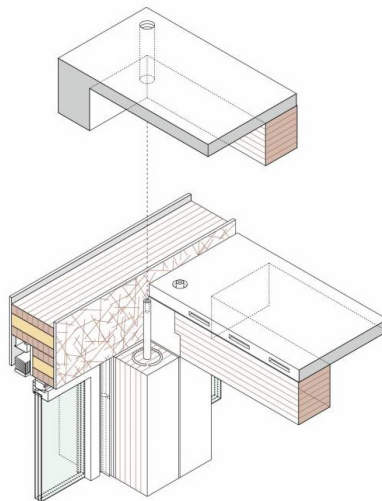

Fig.39: Fitting of wood-concrete composite slab panel onto hollow pin provided in the column cap.

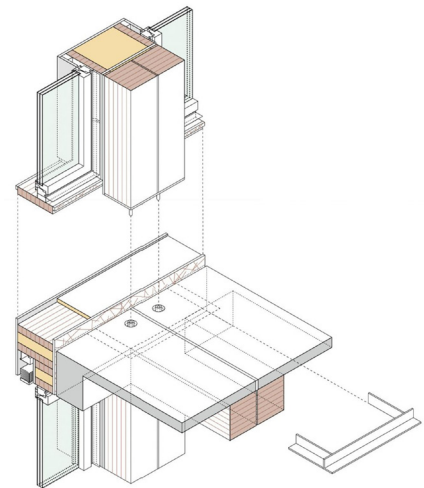

Fig.40: Assembly of upper facade panel with the pins attached to the column base fitted into steel tubes

posites and have a triple glazing. Aluminium was chosen because it is a non-combustible material.

- Technical

Technical services include: the ventilation, power supplies, pipes, smoke detectors, sprinklers and lighting systems. They have been prefabricated into the ceiling space in-between Glulam beams. Ceiling panels are fastened accurately onto the underside of the hybrid slabs as a partial cover for the technical services. The ventilation ducts can be freely seen at some places. Additional building services such as motion detectors, occupancy sensors, power supply to the façade, fire extinguishing systems can all be added optionally.

- Discussion

CREE claims a 90% improvement in CO₂ in comparison to a standard non-timber build-

ing.⁷⁸ Over 260 tons of CO₂ are to be stored and another 320 tons to be saved by using timber as a substitute for conventional construction materials.⁷⁹ CREE claims that LCT One Tower complies with passive house standards.

The potential for disassembly, reuse and recycling is not presented in detail. The elements are hybrid and therefore at best it can be assumed that the deconstruction would be highly energy and time consuming. Although simple joining systems were used to assemble the building there is mention of steel and concrete reinforcing that is laid over the connectors. For example: joints between the slabs are filled with polyurethane foam and then non-shrink grout is poured over it⁸⁰.

⁷⁸ Cree; Cree Buildings; The Natural Change in Urban Architecture, 27.2.2015; ; retrieved from <http://www.slideshare.net/rethinkwood/lifecycle-tower-hybrid-timber-system>; 5.2.2015

⁷⁹ Arup; Arup projects; Life Cycle Tower; retrieved from http://www.arup.com/Projects/LifeCycle_Tower/Details.aspx; 5.2.2015

⁸⁰ Tectonica-online magazine; document:Office Building in Dornbirn; pp 10; <http://www.tectonica-online.com/projects/41t70/>; 6.2.2015



Fig.41: Life Cycle Tower exterior

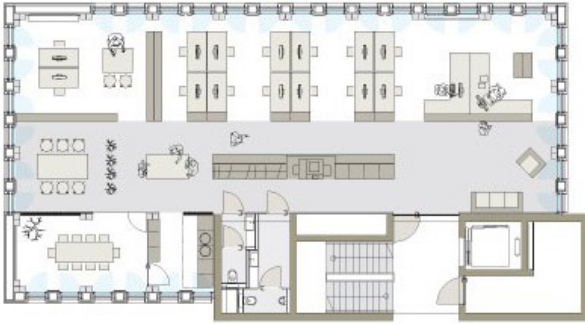

Fig.42: Life Cycle Tower floor plan

It remains unclear how this process would be reversible. In addition to hybrid system, walls are protected with fire-proof cladding to ensure the required fire rating is achieved. This will undoubtedly lower the options when the building gets to its end of life cycle.

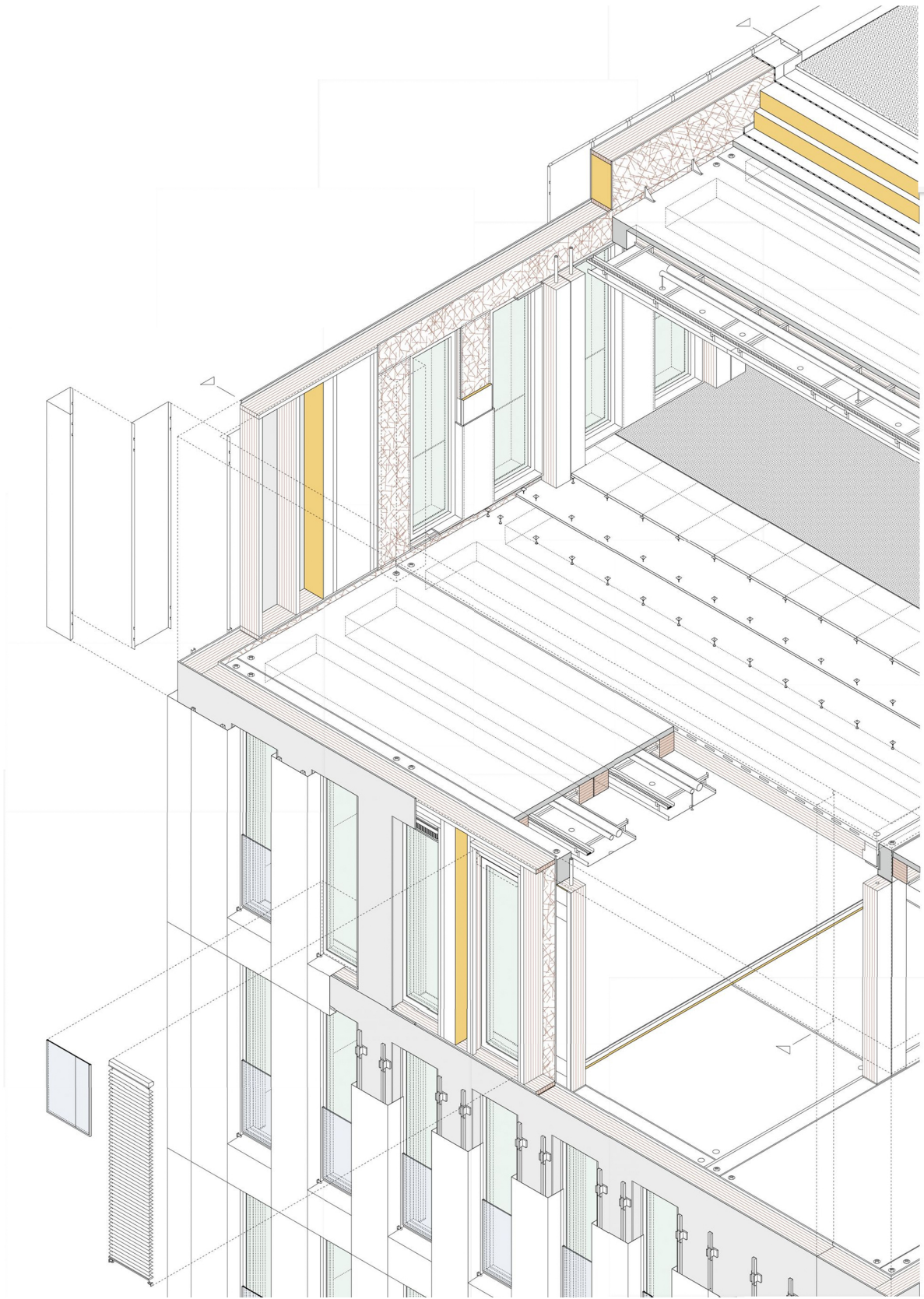

Fig.43: LCT axonometrics

Switzerland, Zurich, 2013

Building: Tamedia AG Building

- Facts

Height: 26,32m, (7 floors)

Floor Area: 8 905 m²

Volume: 39 085 m³

Architect: Shigeru Ban Architects

General planner: Itten+Brechtbühl

General contractor: HRS Real Estate Wooden

Construction: Blumer-Lehmann AG, Gossau

The Contractor claims that the aim was to make this building as sustainable as possible⁸¹. Roughly 80 per cent of construction components, including the timber construction, as well as the glass facade, stairs, interior glass partitions and cooling ceilings were completed in prefabrication stage. Within the construction period from May 2011 until

March 2013, four months were allocated for timber erection and two months for interior fitting. This is an office building and it provides a workplace for around 480 people.

- Base:

The double height ground floor and 5 floors above it sit on 2 concrete underground levels.

- Core

Two concrete cores, one in the new part and one in the adjacent existing building, provide lateral bracing.⁸²

- Load bearing

The defining feature of this project is an interlocking wooden lattice primary load bearing structure where the timber columns span throughout the entire height of the building. The load bearing system is entirely prefabri-

⁸¹ Tamedia; The New Tamedia Building; retrieved from <http://www.tamedia.ch/en/company/tamedia/the-new-tamedia-building/>; 6.2.2015

⁸² Cohn David; Tamedia Headquarters Expansion; July 2014; retrieved from <http://archrecord.construction.com/projects/portfolio/2014/07/1407-Tamedia-Headquarters-Expansion-Shigeru-Ban-Architects.asp>; 6.2.2015



Fig.44: Tamedia building in construction phase

cated out of timber, with no additional reinforcements. Not only columns and beams, but also joint connections are prefabricated out of Timber. Instead of screws, nails or steel connectors, special dowels, developed by Hermann Blumer, were used. The wood used in construction was Spruce from Styria and 2,000 m³ in total were needed.⁸³

There are 8 load bearing frames. Each comprises of four 21m high columns and five 17.5m long double beams. Each column is made of three glue-laminated block-bonded timber components. They are 21m tall with a cross section of 440x440 mm and weigh 2.5 tons each. Double beams have a 240mm width (120mm each beam), span 11m across the building's main tract, are cambered at 25 mm and weigh 24 tonnes in total. The load bearing frames are positioned 5.45m apart.⁸⁴

⁸³ Tamedia; The New Tamedia Building; retrieved from <http://www.tamedia.ch/en/company/tamedia/the-new-tamedia-building/>;6.2.2015

⁸⁴ Brandt Katarina; Japanese details & Swiss precision;12.9.2013; in Swedish Wood,Wood Magazine; retrieved from <http://www.woodarchitecture.se/stories/japanese-details->

The column to beam joints have been specially crafted from beech plywood. The precisely balanced geometry of the joint form contributes to its impression – a fact that the architect placed great importance in.

3D modelling and CNC milling machines with extraordinary precision were required for these components. Precision of fitting and geometry played a central role in the planning and production of the structure. The beam pairs are attached to a large, oval beech plywood dowel placed into a precisely milled oval notch within the column. Two oval beech plywood panels reinforce the reduced column cross section along the joints, enabling controlled introduction of loads.⁸⁵ The loads are transmitted via contact and exact fitting was a prerequisite for planning and production. The connections are additionally stabilized by the pressure of the secondary structure.

swiss-precision ;6.2.2015

⁸⁵ Antemann Martin; Seven Storey Timber Office Building in Zurich; in DETAIL; Institut für Internationale Architektur Dokumentation GmbH&CO, München;Jan 2014; pp: 61



Fig.45: Transportation of elements

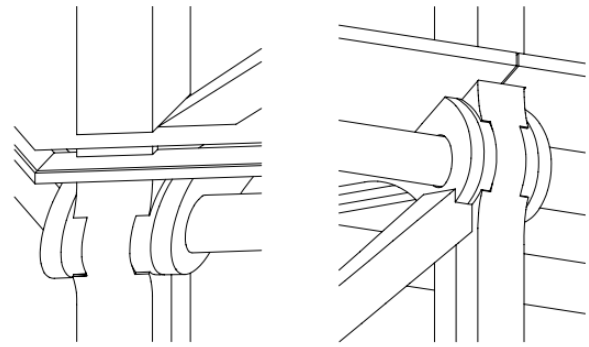

Fig.46: Glulam joints

Corner guards and foil were used to protect the primary structure during transport and storage. Since the load bearing system and tolerances reverse when the element is elevated, cracking sounds could be heard until the connecting surfaces were in proper alignment.

- Secondary system

Ceiling and floor elements measure 2.70x5.30m. The hollow-core elements were prefabricated and assembled with wood joists, three-layer timber board, and gypsum and cement board. Nails and screws were used as fasteners. Sand infill between the joists was used to dampen vibration and provide thermal inertia. The ceiling and floor elements provide the necessary thermal storage mass, as well as improve sound proofing.⁸⁶

After the insertion of the floors and ceilings

came the installation of the glass façade. In order to reinforce and express the conceptual idea the building skin is entirely transparent through the use of Wicona aluminium glass systems. Wicona's Wicline 75 SK system has been used to create a complex triple glazed façade, which achieves a U value as low as 1.0W/m²K.⁸⁷ Double façade system spans along the 60m long side of the building acts as a thermal buffer and helps with the natural ventilation of the building. The retractable window system allows for "transforming" these spaces into open air terraces.

- Discussion

A double facade facing the Sihl river acts as a natural ventilation system. The building will also be operated without CO₂ and will not make any use of nuclear power. Moreover, fossil fuels are eliminated thanks to a futur-

86 Cohn David; July 2014;

87 Wicona; Magnificent double skin glass façade created using WICONA glazing systems; 3.9.2014; retrieved from <http://www.wicona.at/en/About-WICONA/News-and-events/17027/>; 6.2.2015



Fig.47: Tamedia interior

istic heating and cooling system that utilises the groundwater,⁸⁸ Good thermal insulation and the use of heat pumps keep the operating costs of the first carbon-neutral wooden skyscraper in Switzerland low.

The fact that the primary construction is made exclusively out of timber makes this project perfectly suitable for disassembly. However the reuse of the elements in their original state will not be possible due to the fact that every single part was specifically made for this construction. A potential remains for down-sizing, redesigning of the parts and then later re use because the structural elements are all entirely made out of Glulam. Also, all Glulam timbers went through a separate inspection to ensure their load-bearing capacity in the event of a fire. There is a sprinkler system but no extra coat-

ings or materials were used in order to provide fire safety. What remains up for discussion is the sustainability of Glulam itself as a composite material.

At least a disassembly is ensured without any necessary energy input for separating different materials from each other. It is a first step into a new perception of the building process.

88 Tamedia; The New Tamedia Building; retrieved from <http://www.tamedia.ch/en/company/tamedia/the-new-tamedia-building/>;6.2.2015

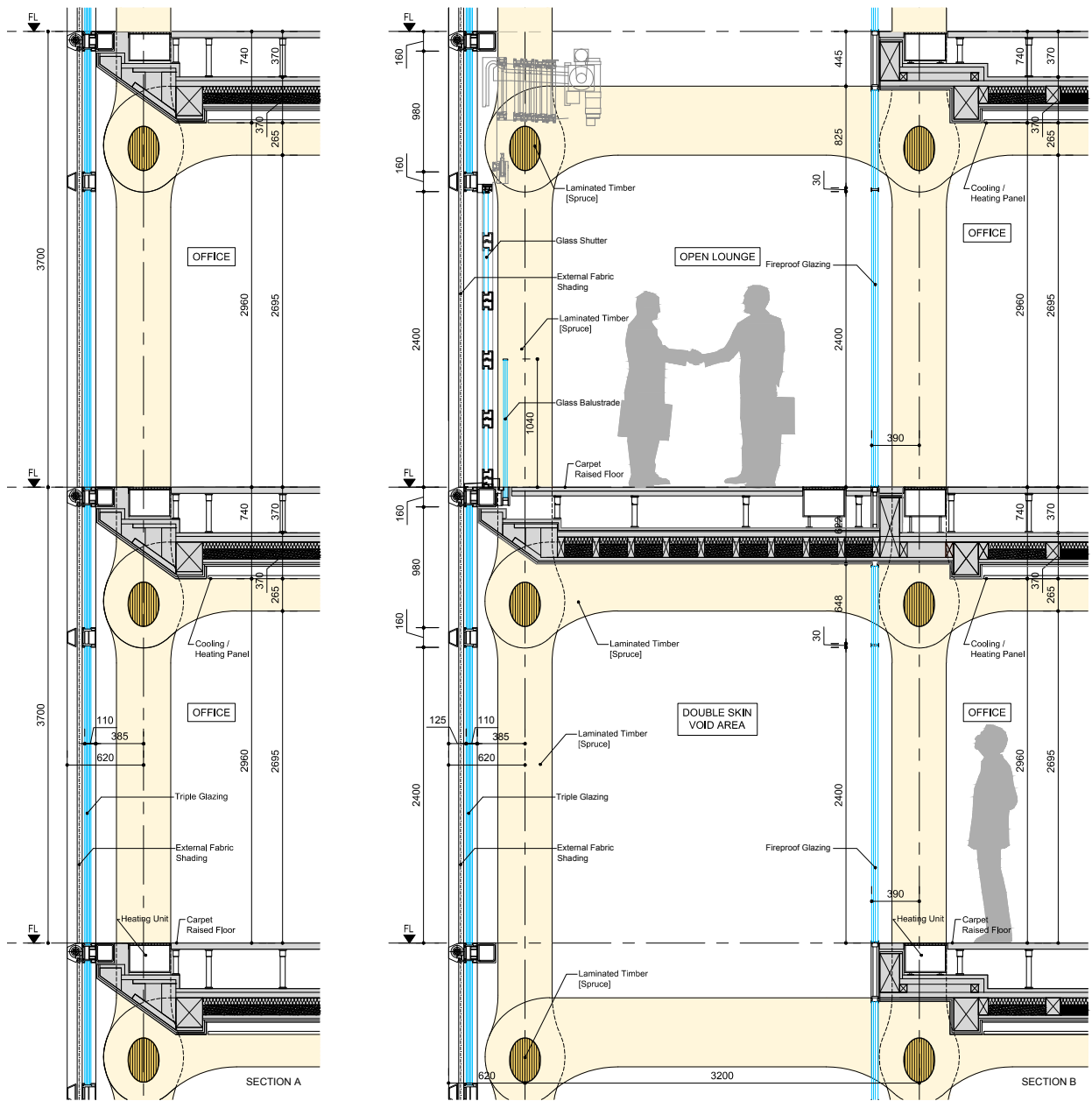

Fig.48: Tamedia, section plan

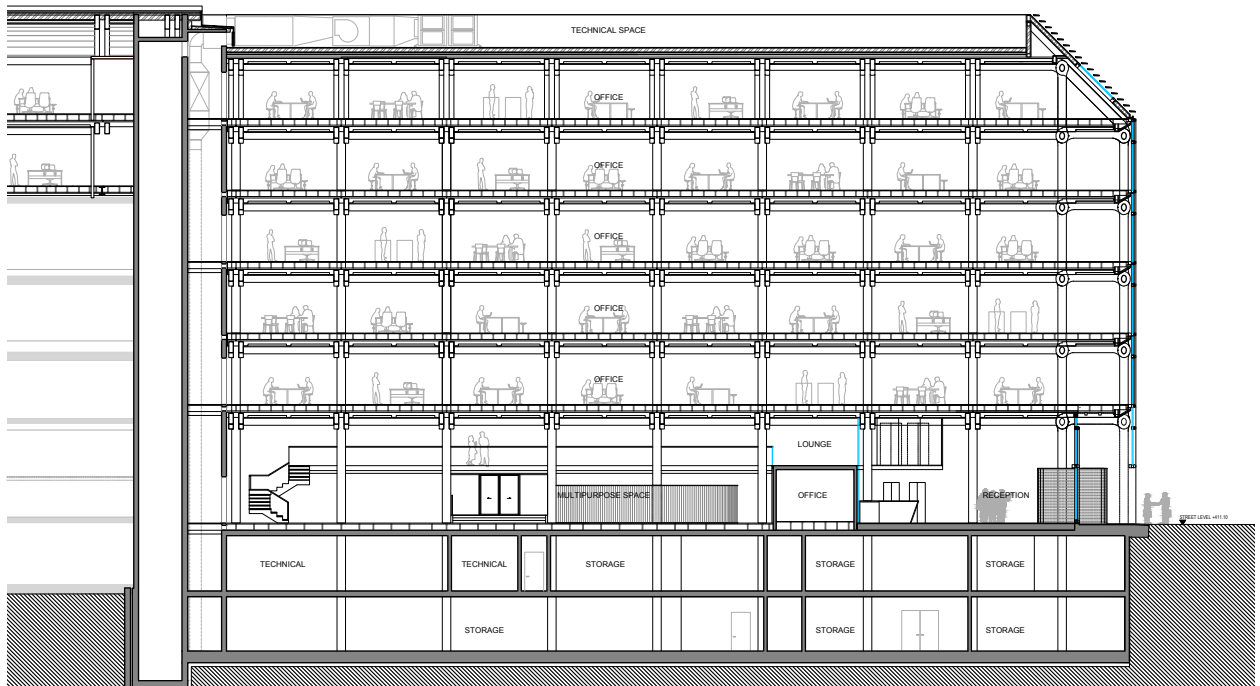

Fig.50: Tamedia section full height

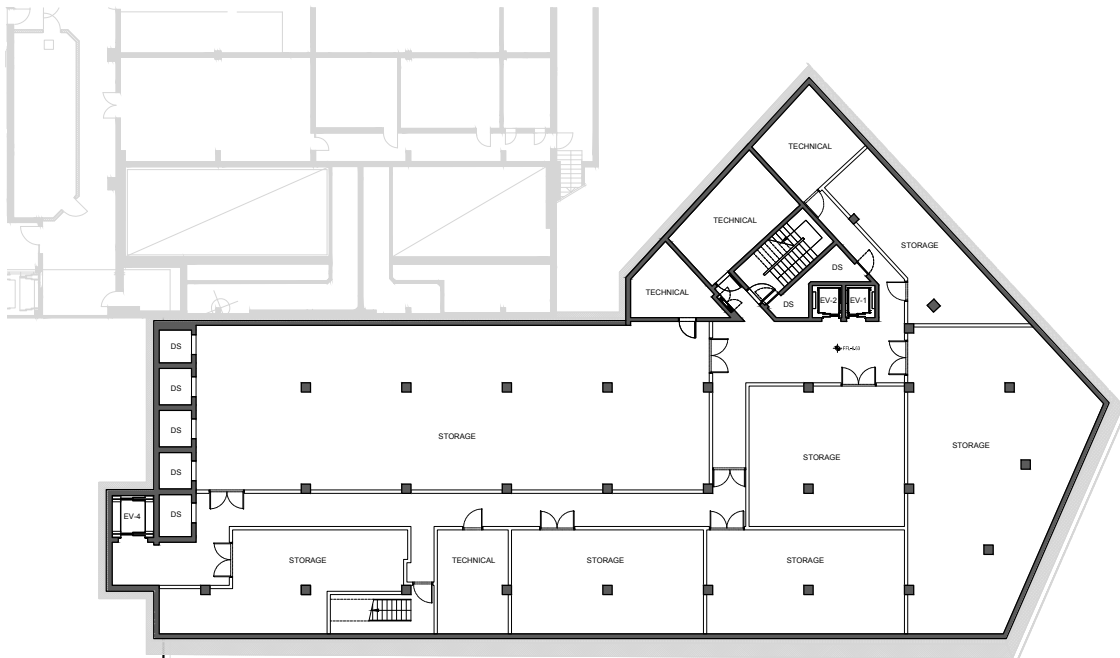

Fig.49: Tamedia floor plan

Norway

Building: Treet

- Facts

Height: 14 floors, 45m

Architecture: Artec

Contractor: Bergen and Omegn Boligbyggelag

Engineering consultant: SWECO

Timber structure: MoelvenLimtre

Building modules: Kodumaja (Estonia)

Brutto Area: 3780 m² (heated BRA)

Netto area : 5830 m²

This is a currently ongoing project. Construction started on 6.10.2014 and it is expected to reach full height by May 2015 with tenants moving in by end 2015. There will be 62 apartments ranging between 41 and 66m² in size. Once finished it will be the highest built timber construction building. What makes this building system a competitor on

the market beside it's carbon footprint is it's faster construction time in comparison to on site building.

- Base:

The hybrid timber construction will be positioned on top of a concrete underground garage underneath which more than a hundred vertical and tilted steel core piles will be driven into a 5m deep bedrock.

- Core:

The core, including the elevator shaft and the staircase, is to be completed in CLT panels. The panels used are 15m high, which means that only 3 were needed to reach to needed height.⁸⁹ The CLT construction is not connected to the external Glulam system. Because of their different characteristics the designers were not comfortable in directly connecting

⁸⁹ Abrahamsen R, Bergen Project- The Design and Construction of the World's First 14 Story Wood Building; video retrieved from https://www.youtube.com/watch?v=e5XsqauBCX4&list=P_Lip3ehq5Y9MSRWwAkpTP9YV0tAIFL8KIB&index=3; 12.2.2015

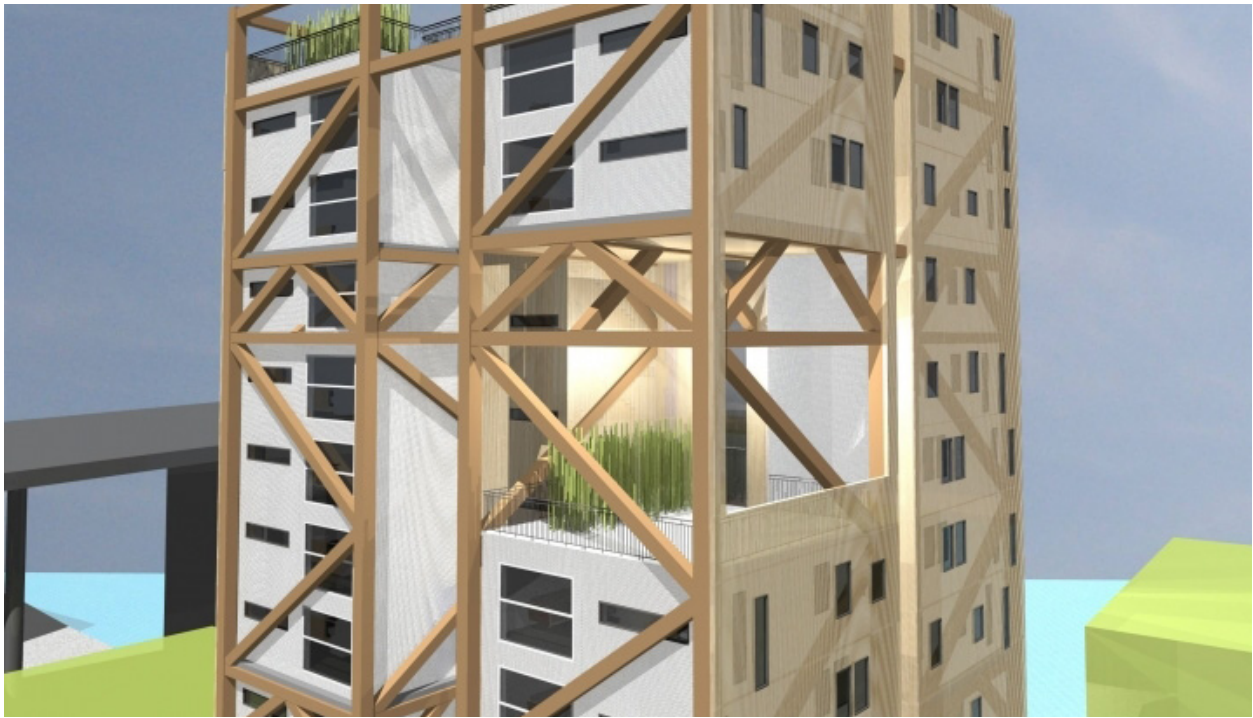

Fig.51: Treet building 3d realisation

the systems, and neither was it necessary. The CLT elements in the shafts are not structural elements in the design. They only act as vertical bearing for the stairs and elevators.

- Load bearing:

This is a hybrid building system. It is a combination of prefabricated 3D modules (timber framework) as well as linear (Glulam and CLT) elements. In total 550 m³ of Glulam and 385 m³ of CLT are to be used. The majority of the Glulam is made out of untreated Norway Spruce. Glulam that can be exposed to weathering is made of copper-treated lamellae from Nordic Pine. Structural timber in the building modules and CLT is produced from Norway spruce.

Conventional prefabricated modules can be safely stacked up to 6 stories. Stacking 4 storeys is proven to be quite economical. Therefore, to enable higher construction, an external load bearing Glulam lattice has been

designed as the main load bearing system.

Typical sizes used for the lattice elements are 405x650mm and 495x495mm for vertical columns and 405x405mm for diagonal trusses.⁹⁰ The Glulam trusses along the façades give the building its necessary stiffness. All Glulam elements are connected by slotted-in steel plates and dowels.⁹¹ This is a high capacity connection commonly used in bridges and large buildings. The joining technique was chosen because the engineers and Glulam manufacturer were familiar and confident with the type. The steel plates in the connections have steel grade S355 and are hot dip galvanized. The steel dowels are of type A4-80 (acid-proof stainless grade).⁹²

⁹⁰ Abrahamsen R., Bergen in a wood construction fever – the first 14 storey building; at International Wood Symposium. Vancouver, 23.1.2014; pp:58; retrieved from <http://wood-works.ca/wp-content/uploads/5-rune-abrahamsen-bergen-in-a-wood-construction-fever.pdf>; 12.2.2015

⁹¹ Abrahamsen R., 2014; pp:19;

⁹² Abrahamsen R, Malo K.; Structural design and assembly of "Treet" – a 14-storey timber residential building in Norway; at World conference on timber engineering; 10.8.2014; pp:5; retrieved from: http://scho.wa/hosted_files/wcte2014/9d/ABS624_Abrahamsen_web.pdf; 12.2.2015

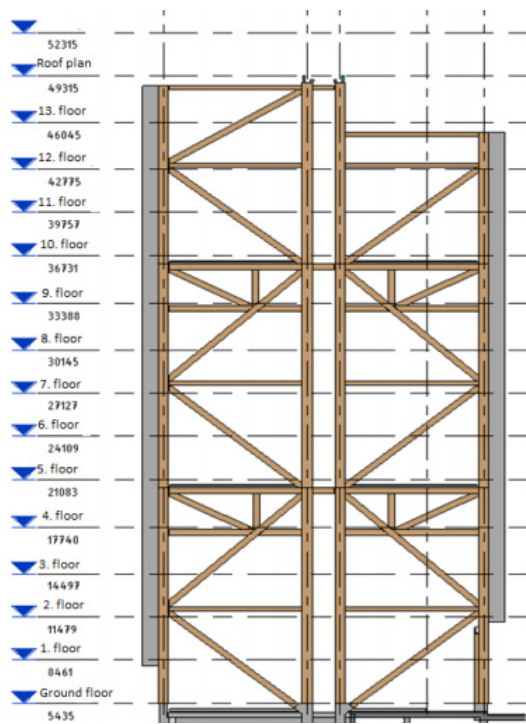

Fig.52: Treet building external load bearing structure

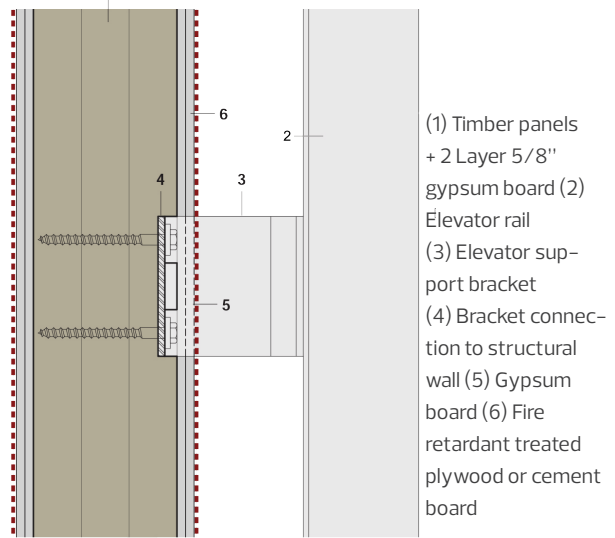

Fig.53: Treet building CLT core, shaft

The use of galvanized steel ensures that rust water will not discolour the timber during the assembly.

The basis of the prefabricated modules is timber frame work. Each module is completely prefabricated and complies with passive house standard. Floor and roof are constructed with timber beams; plasterboard, oak parquet finishing, wall-hung toilet, shower dishwasher, cupboards, kitchen, shower, tiles and all technical installations such as sprinklers, electricity, water pipes are all pre-installed and ready for use. All that is left is to connect the systems.

Modules are prefabricated in two sizes: 4x8,7 m and 5,3x 8,7m. From a construction point of view, using individually sealed and almost air-tight modules reduces the challenge with water and moisture in the building phase considerably. The modular system provides double walls between apartments which puts the acoustic requirements well within limits

for apartment buildings.⁹³

Modules are stacked in 4 level groups. Levels 1-4 rest on the deck of a concrete garage and are not connected to the surrounding load bearing structure. Level 5 is a "power storey" level: it is a strengthened Glulam storey connected to the external Glulam structure and does not rest on the building modules below. The "power storey" carries a prefabricated concrete slab on top, which acts as a base for the next four levels of stacked modules (levels: 6-9). The modules on levels 6 to 9 do not connect to the main load bearing structure at any other point than at their foundation, which is the concrete slab. The system then repeats itself with an additional "power storey" (level 10) and modules on top of that again (levels 11-14). Other than acting as a carrying base for the stacked modules the concrete adds weight to the building so its more stable in the wind. A possible 70mm

93 Abrahamsen R; 2014; pp:59;



Fig.54: Treet building interior

max deflection has been calculated.⁹⁴

There is a clearance of 34mm between building modules and Glulam trusses. This is enough to ensure the necessary building tolerances, and to avoid possible interference between horizontal movement of modules and trusses. The possible wind load will not affect the modules directly (except during the erection phase) but rather it is the diagonals and columns that will take on the tensile forces that appear. These forces are transferred to the ground by joints that are anchored to the concrete foundation. It has been verified that in case of a failing timber element the building will not collapse as the other elements will simply take over more forces.⁹⁵

The construction system was very much in-

fluenced by the fire protection strategy. The main load bearing system must resist 90 minutes of fire without collapse. Secondary load bearing systems, such as corridors and balconies, must resist 60 minutes of fire exposure. A charring rate of 0,7mm/min leads to a charring depth of 63 mm after 90 minutes. Based on this calculation, 7mm were added to reach the effective residual cross-section.⁹⁶ All steel connectors, plates and dowels, are placed inside the timber at a minimum distance of 70 mm from the outer surface. All gaps between connected timber members are blocked with a fireproof joint filler. In this way the load bearing system will not fail within the required fire resistance time.⁹⁷

- Secondary structure:

The internal CLT walls are independent of the main load bearing system, and are not re-

94 Abrahamsen R, Malo K. 2014; pp:2-4

95 Bjertnæs M., Malo K. Wind-induced motions of "treet"; 10.8.2014; pp:1-4; retrieved from: <http://www.sweco.no/Global/Norway/Areas%20of%20operation/Bygg%20og%20konstruksjoner/Projects/WIND-INDUCED%20MOTIONS%20OF%20TREET%20-%20A%2014-STOrey%20TIMBER%20RESIDENTIAL%20BUILDING%20IN%20NORWAY.pdf>; 12.02.2015

96 Abrahamsen R.; 2014; pp:20

97 Abrahamsen R, Malo K. 2014; pp:4

sponsible for horizontal stability of the building.

Glass facade (on north and south) and metal sheeting facade (east and west) protect the structural timber from rain and sun. The external cladding and glazing of the building are attached to the load bearing trusses and to the balconies.

Kodumaja and Moelven Limtre use a tower crane as well as a climbing scaffolding system during the building erection.⁹⁸ Temporary roofs are used to protect apartments, joints and timber from moisture during the building process.

- Discussion

Although an example of a hybrid system in terms of materials and different systems within one project, the Treet building exhibits a high potential for disassembly and reuse.

⁹⁸ Abrahamsen R.; World's tallest timber building, Bergen; 26.9.2014; pp:3; retrieved from: http://forumholzbau-nordic.com/assets/bilder/Presentations/Abrahamsen_Worlds_tallest_Bergen.pdf; 12.02.2014

It is the separate functions of the individual parts and the way that they are connected that allows for this. Modules are self sufficient units, and what is more important they are connected to the external load bearing structure only at a minimal number of points. One can assume that they can easily be disassembled from the whole structure, replaced, and used at a different location.

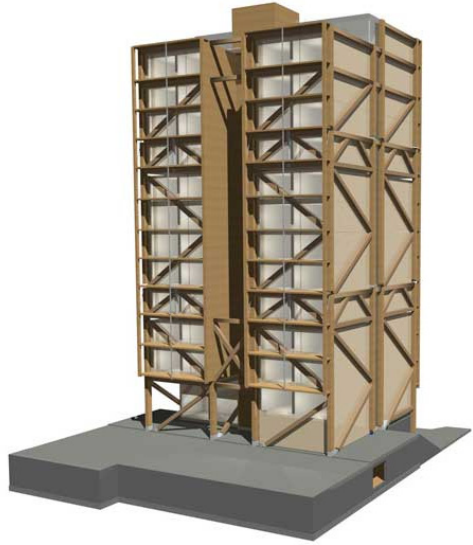
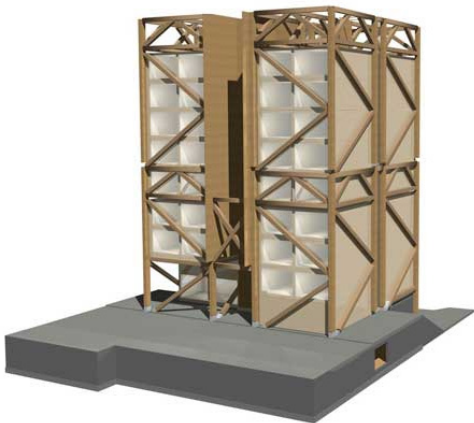
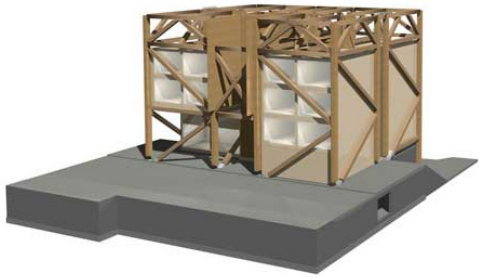
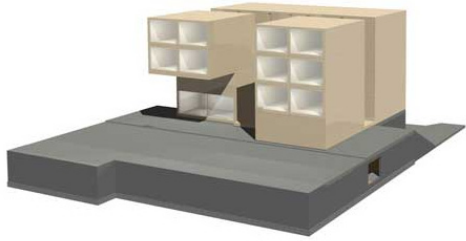

Fig.55: Treet building assembly scheme

Australia, Melbourne

Building: Forte

- Facts:

Height: 32.17m, (10 stories)

Floor area: 1937m²

Developer: Lend Lease

Cost: 8.8 million euro

Forté Apartments in Melbourne, Australia are currently the highest building with a timber construction. It is Australia's first large CLT building and a landmark project for the whole timber industry in Australasia. The choice of CLT material are particularly relevant to the projects location. Being close to the Victoria Harbour meant poorer than usual ground conditions. The benefits of using wood in comparison to usually used concrete meant an 80% weight reduction which in turn meant less mass for the foundation to support resulting in substantial savings on be-

low-ground construction of the foundation⁹⁹. Also major benefits were seen in speed and safety of the construction process. It

In the design are 23 apartments between 59m² and 102m² and a commercial ground floor. Mark Menhinnitt, CEO of the developer Lend Lease, anticipates that 'this project will unlock a new era for sustainable development by offering a viable alternative to traditional construction options, which are carbon intensive' [62] and that 'in future 30 to 50 per cent of their residential projects could be executed in CLT'¹⁰⁰.

- Base

Ground level was designed in concrete which provides for a stronger base and rises the wooden construction out of reach from ter-

99 Lend Lease, FORTé Creating the world's tallest CLT apartment building; 2013; pp:9;

100 Halkett J.; Wooden building revolution; in AWISA the Magazine; Austum 2014, pp: 13; retrieved from: <http://www.clt.info/wp-content/uploads/2013/08/2014-04-AUS-The-AWISA-Magazine-The-Docklands-Library-Wooden-building-revolution.pdf>; 12.2.2015



Fig.56: Forte building

mites. Also space function was taken into account and because the ground floor was going to be used for commercial purposes the architects preferred to have a different grid compared to the load bearing CLT walls on the levels above.¹⁰¹ There is no underground level, the concrete ground level is standing on deep driven pillars.

- Core:

The core of the building including the elevator shaft and emergency staircase is also prefabricated in mass timber panels. To achieved the required safety levels a double boxed design was used.

- Load bearing

The primary system is linear and consists of load bearing CLT walls. The walls are constructed from 760 CLT panels that were

shipped in 25 containers from Austria's manufacturer KLH. The panel size was limited to 12 meters length due to shipping container size.

CLT system erection began in June 2012 and was completed in August 2012. In the assembly process, around 25 panels per day were put in place¹⁰².

Walls themselves were prefabricated with CLT Double Panels (2x123mm thickness) with 1x13mm FRPB lining and including furring channels and insulation to one side.

The inner CLT skin is protected by interior wall linings. The outer CLT skin is protected by façade cladding. Floors are also made up of CLT.¹⁰³ Panels used had a thickness of 146mm, concrete screed with uniroll and a double layer of FRPB ceiling.

Detailing CLT elements and their connectors

¹⁰¹ Daryl Patterson; Forte - Creating the World's Tallest CLT Apartment Building; 20.9.2013; video min: 3.00-4:00 retrieved from: <https://www.youtube.com/watch?v=pHpthNBiYqE>; 12.2.2015,

¹⁰² Lehmann S.; Sustainable Construction for Urban In-fill Development Using Engineered Massive Wood Panel Systems 18.10.2012; pp:2728; retrieved from: www.mdpi.com/2071-1050/4/10/2707/pdf; 12.2.2015

¹⁰³ Lend Lease, 2013; pp:57;

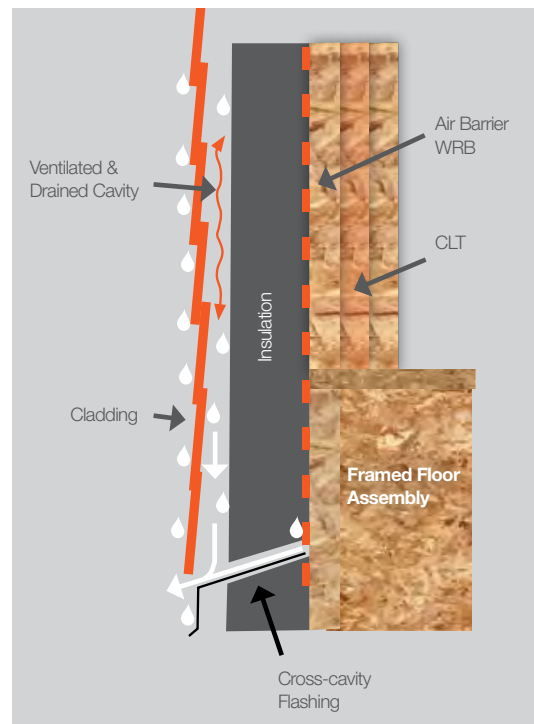

Fig.57: Rain screen facade

(KLH manufacturer) was discussed in chapter 4 of this thesis document. Three different panel types were used for load bearing structural elements and all passed pretests for fire performance:

- FR90/90/90:128mm wall panel with 13mm fire grade plasterboard direct fixed
- FR90/90/90: 158mm wall panel bare
- FR120/120/120: 146mm floor panel with 2 layers 16mm fire grade plasterboard.¹⁰⁴

The developer claim that a 15 storey height can be achieved with exactly the same system. While a 20 storey height would require some structural changes.

- Secondary system

Facade is made up of CLT Panel [128mm or 158mm thick], rain screen and scaffolding. The surface material is Alubond, a recyclable metal prefabricated to required panel sizes.

¹⁰⁴ Lend Lease; 2013, pp: 35–36;

Between Alubond and CLT there is a cavity which has a vapour barrier and an insulation layer. The rain screen facade system was chosen to protect the CLT system and improve its durability.¹⁰⁵ The developer decided on “a more ordinary façade to have a building not completely out of the ordinary”. Ventilation cavity draws heat away from timber.¹⁰⁶ Bathrooms were prefabricated and brought to site as ready to use 3D modules.

- Discussion

According to the developers, by using CLT, Forté will reduce carbon emissions by more than 1600 tonnes of CO₂, compared with building in concrete and steel which is the equivalent of removing 400 cars from our roads.¹⁰⁷ The building is predicted to be 30%

¹⁰⁵ Daryl Patterson; Forte – Creating the World's Tallest CLT Apartment Building; 20.9.2013; video min:1.20–2.00 retrieved from: <https://www.youtube.com/watch?v=pHpthNBiYqE>; 12.2.2015,
¹⁰⁶ Lehmann S.2012; pp:22
¹⁰⁷ XLam; Case studies, Projects; Lighter Footprint; pp:93; retrieved from: <http://www.xlam.co.nz/system/files/web-editor/ForteTrendzJuly13.pdf>; 12.2.2015

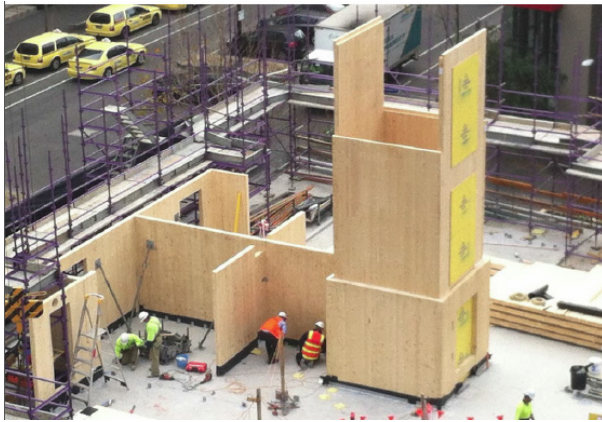

Fig.58: Forte construction process

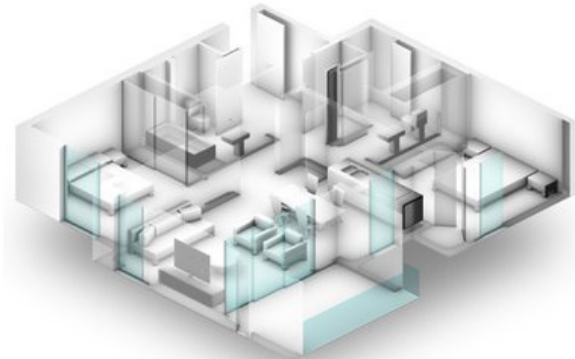

Fig.59: Forte apartment 3d realisation

faster to build, had less construction traffic, caused less disruption and less waste than if it was constructed with other materials for example concrete or steel. Lend Lease founder, Dick Dusseldorp, believes that :The time is not far off when companies will have to justify their worth to society, with greater emphasis being placed on environmental and societal impact than straight economics.¹⁰⁸

High Performance Windows allow the light in while reflecting heat. The window framing technology minimise air leakage. The elevators have regenerative braking, which is a power off feature resulting in lower standby power. The appliances are energy efficient . Low energy lights, are used. Overall , all energy saving features should amount to 25 per cent less energy to heat and cool than a similar apartment built in reinforced concrete;

¹⁰⁸ Lend Lease; Forté – Building australia's first timber High-rise; 6.2.2013; pp:7; retrieved from: <http://www.woodworks.org/wp-content/uploads/2013-WSF-ATL-Collins.pdf>

There is a rainwater tank on the ground floor for reuse in toilet flushing which should save water. Steel joints are made from recycled steel. All apartments will have smart meters which link to an in home display and show real time and historic data on energy consumption. ¹⁰⁹ For moisture protection CLT walls have been protected by sarking and cladding and a rain screen facade. Moisture content is kept around 12%. The thermal envelope that CLT panels provide is very pleasant: with an outside temperature of 34 Celsius, while indoor temp will be 17 Celsius without any cooling system in place.

Despite all of these positive features of Forte building it is interesting to hear that the timber surface interior was cladded in order to “reduce the timber aesthetic, to avoid mar-

¹⁰⁹ Lend Lease; The Lend Lease Sustainability Plan; Case Study AUSTRALIA FORTÉ; pp5; retrieved from: http://www.lend-lease.com/~/-/-/-/-/media/Group/Lend%20Lease%20Website/Australia/Documents/Sustainability/Forte_Case%20Study.ashx;12.2.2015

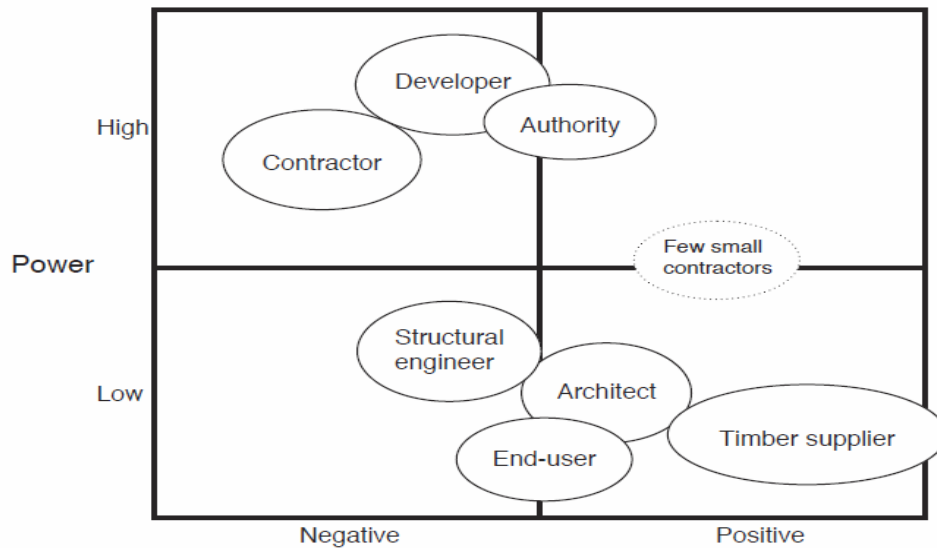

Fig.60: Attitude towards timber

keting risks'. The developer also decided that 'the building would be fully sprinkled to make it look safe and simplify the approval process, although this measure was not requested by the Fire Department'. (Forte relies on both charring principle and supplementary coating as a fire protecting system), This facts shows how complex the design process is and how many things must be considered from the beginning of the design process for a completion of a successful project.

In terms of design for disassembly, it goes in favour of this system is that it is very homogenous, made up almost entirely of CLT elements. On top of that, the CLT elements are connected with bolts and screws, a technique that is potentially easy to dismantle. It remains questionable in what state the dismantled elements will be at the end of life cycle. Will they be damaged once the metal

connectors are all disconnected.

The Netherlands, Delft

Project: Disaster shelter project

- Facts:

Height: single level

Architect: Pieter Stoutjesdijk

Production: ECO-nnect

This currently ongoing project illustrates the collaboration of fast digital fabrication, natural materials, engineered materials and digital fabrication, and suggests its potentials. The goal was to design a disaster shelter that would be fast to erect, cheap, simple to be constructed in an area shortly after it is hit by a disaster. Preferably it would be made of local material, prefabricated on the location itself. The erection time for a single unit is aimed at 24 hours.

This project is a result of a collaboration with ECOboard and based on research work con-

ducted at Technical University in Delft. It is currently being developed for application in fast growing countries like Senegal, Rwanda and Thailand.

- Load bearing system:

The building system developed for the Disaster shelter project is entirely composed of ECOboards which are locally produced sheet material from what is today considered agricultural waste because they are seen as unsuitable source for food or fuel. The panels are made out of agricultural residues such as straw or reeds, bonded together with the natural lumen of the cellulose fibres. These sheets, produced by ECOboard, store 1,6 times their weight in CO₂. As the building system is designed with integrated CNC cut friction fit connection, no glue or fasteners are required to bond the sheets.

It is to be noted that this is an ongoing project and adjustments are still being made in order



Fig.61: EcoBoard Prototype

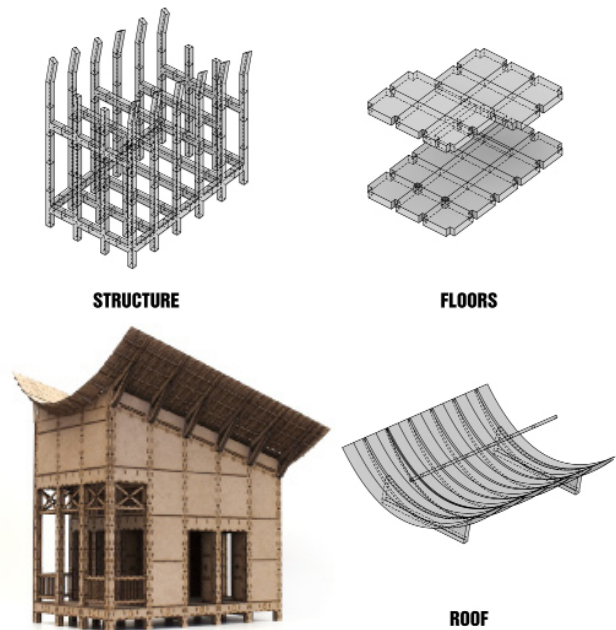

Fig.62: Project design

to optimize it and make the production available.

CNC machine milling and computer software were used in design and production. The system is transported as a flat-pack system. Once delivered the 2d elements are hammered into position. No other tool is needed.

- Project features

The developed digital design process and building system are tested and specified via the design of a transitional shelter for Villa Rosa; an informal settlement south east of Port-Au-Prince, Haiti¹¹⁰. The specific advice and adjustments in the design process are merged in a concept that perfectly fits its climatic, cultural, technological and historical context. A concentrated solar power system integrated in the parabolic roof provides three basic needs: protection, electricity and

¹¹⁰ Stoutjesdijk P. (2013). TU Delft thesis

clean drinking water. The ornamentation made possible by the building system demonstrates similarities with Haitian vernacular architecture of highly decorated gingerbread houses.

The production stores 1.95 CO₂ eq, after completion the roof produces daily 12,9 kWh of energy and 130 litres of water.¹¹¹

- Discussion

The reason for the development of ECO Boards was the fact that because of its natural environment the Netherlands do not have an abundance of wood.

This is not a high-rise timber project but it is the projects that was the inspiration for the topic of this thesis. It illustrates an out-of-the-box way of thinking and I believe that it is ultimately these project that will lead to biggest innovations and bring change.

¹¹¹ Stoutjesdijk P. (2013). TU Delft thesis



Fig.63: Joint principle

It is exactly because countries like the Netherlands do not have a long tradition of building with wood, that they will not be lead by customs and tradition, and therefor can be expected to come with innovations. All countries need to start building energy neutral and effectively. Bringing the pieces together and learning from each other is the way to go .

References

- Anderson, C. (2012). The new industrial revolution; New York. Crown Business.
- Arup. (2015). Arup projects: Life Cycle Tower; Source http://www.arup.com/Projects/LifeCycle_Tower/Details.aspx.
- Abrahamsen R. (2014). World's tallest timber building, Bergen. Source: http://forumholzbau-nordic.com/assets/bilder/Presentations/Abrahamsen_Worlds_tallest_Bergen.pdf
- Bjertnæs M., Malo K.(2014). Wind-induced motions of "Treet". Source: <http://www.sweco.no/Global/Norway/Areas%20of%20operation/Bygg%20og%20konstruksjoner/Projects/WIND-INDUCED%20MOTIONS%20OF%20TREET%20-%20A%2014-STO-REY%20TIMBER%20RESIDENTIAL%20BUILDING%20IN%20NORWAY.pdf>.
- Bayer (2015). Purbond: Adhesives for modern timber construction. Source: http://www.klh.at/fileadmin/klh/kunde/2011/Kreuzlagenholz/Verleimung/Purbond_-_Adhesives_for_modern_timber_construction.pdf.
- Buchanan, A. (2001). Structural Design for Fire Safety. Source: <http://magazine.sfpe.org/content/highrise-timber-buildings>.
- Buchanan A. (2014). Resilient Seismic Design in Multi-Story Wood Buildings. Source: <https://www.youtube.com/watch?v=NIE4eWf89xo>.
- Crowther P. (2005). Design for disassembly: Themes and principles. RAIA/BDP Environment Design Guide. Source: <http://eprints.qut.edu.au/2888/1/Crowther-RAIA-2005.PDF>
- Cree Buildings. The Natural Change in Urban Architecture. Info brochure. Source: <http://www.creebuildings.com/files/CreeBrochure.pdf>.
- Daryl Patterson. (2013). Forte` - Creating the World's Tallest CLT Apartment Building; video Source: <https://www.youtube.com/watch?v=pHpthNBiYqE>;
- Durmisevic E. (2006). Transformable building structures: Design for disassembly as a way to introduce sustainable engineering to building design and construction. Ph.D. Thesis. Delft Technical University.
- EUR-Lex. (2010). Directive 2010/31/Eu Of The European Parliament And Of The Council on the energy performance of buildings. Official Journal of the European Union. Source: <http://eur-lex.europa.eu/LexUriServ/LexUriServ.do?uri=OJ:L:2010:153:0013:0035:EN:PDF; 5.2.2015>
- Emery J. (1986) Formaldehyde Release from Wood Products. Washington D.C. Source: <http://rosboro.com/pdfs/WoodPanelsFormaldehyde.pdf>;
- Guy B., Ciarimboli N. (2005) Design for Disassembly in the built environment. Seattle; Source: <http://www.lifecyclebuilding.org/docs/DfDseattle.pdf; 12.2.2015>
- Green M. (2013). Why we should build wooden skyscrapers. TED Conference. Source: http://www.ted.com/talks/michael_green_why_we_should_build_wooden_skyscrapers/transcript?language=en.
- Gerard R., Barber D., Wolski, A. (2013). Fire Safety Challenges of Tall Wood Buildings. Quincy, MA,
- Harris M. (2012). Wooden high-rise buildings. Engineering and Technology Magazine. Source: <http://eandt.theiet.org/magazine/2012/09/wood-goes-high-rise.cfm>.
- Hechler O. (2011). Life-time structural engineering: Design for durability, life-cycle performance, maintenance and deconstruction. Design for deconstruction. Faculty for the Built Environment, University of Malta. Source: http://lftc.civil.uminho.pt/C25_Final_Outcome_Volume_2_2011.pdf;
- Kaufmann Hermann. Projektdatenblatt: LifeCycle Tower- LCT ONE. Source: http://www.hermann-kaufmann.at/pdfs/10_21.pdf
- Knaack U., Bilow M., Auer T., Hilderbrand L.(2011). Energy. Imagine 05 series. 010 Publishers. Rotterdam.
- Knaack U. (2012). Prefabricated Systems: Principles of Construction. Birkhauser. Basel. 2012;
- Kolb J. (2008). Systems in Timber Engineering: Load bearing Structures and Component Layers. Birkhauser. Basel.
- KLH. (2013). Made for building Built for living Cross laminated Timber. Source: http://www.klh.at/fileadmin/klh/kunde/2011/Download/Kreuzlagenholz_engl.pdf;
- KLH. (2012). Component catalogue for cross laminated timber structures. KLH Massivholz GmbH.
- KNAPP. Source: http://www.knapp-verbinder.com/index.php?option=com_virtuemart&page=shop.browse&category_id=58&Itemid=198.

KNAPP. Source: http://www.knapp-verbinder.com/index.php?option=com_virtuemart&page=shop.browse&category_id=59&Itemid=198.

KNAPP. Source: from <http://www.koch.ch/katalog/uniDoc/Datenbl%C3%A4tter/94.074.0120/Knapp%20Gigant.pdf>

Kolarevic, B. Designing and Manufacturing Architecture in the Digital Age. Source: <http://www.e-architekt.cz/digiarch/ecaade-01paper.pdf>

Kolarevic B; (2001) Digital Fabrication: Manufacturing Architecture in the Information Age. ACADIA.

Lend Lease. (2013). Forté – Building australia's first timber Highrise; Source: <http://www.woodworks.org/wp-content/uploads/2013-WSF-ATL-Collins.pdf>

Lehmann S.(2012). Sustainable Construction for Urban Infill Development Using Engineered Massive Wood Panel Systems. Source: www.mdpi.com/2071-1050/4/10/2707/pdf

Lend Lease. The Lend Lease Sustainability Plan. Case Study AUSTRALIA FORTÉ. Source: http://www.lendlease.com/~/~/~/~/~~/media/Group/Lend%20Lease%20Website/Australia/Documents/Sustainability/Forte_Case%20Study.ashx

Mgb Architecture + Design. (2012). The Case For Tall Wood Buildings; Source: <http://cwc.ca/wp-content/uploads/publications-Tall-Wood.pdf>

Mils F. (2010). Cross Laminated Timber Frames. Briefing note13. Source: <http://www.willmottidixon-group.co.uk/assets/c/r/cross-laminated-timber-frames-v3-april-2010.pdf>

New London Architecture, GL Hearn. (2014). 236 Tall Buildings Planned for London. Source: http://www.glhearn.com/SiteCollectionDocuments/News%20articles/NLA_GLHearn_Dataset_March2014.pdf

Neil Gershenfeld. (2007). Unleash your creativity in a Fab Lab. TED Conference. Source: http://www.ted.com/talks/neil_gershenfeld_on_fab_labs/transcript?language=en

PE International. Source: <http://www.pe-international.com/international/company/about-pe-international/>

Purbond. Adhesives for modern timber construction. Source: http://www.mnamai.lt/uploads/pdf/KLH-5/Purbond_-_Adhesives_for_modern_timber_construction.pdf

Ryan Smith. (2012). Wasted Wood Sees New Life. Source: <https://www.youtube.com/watch?v=f0bWytzMX08#t=118>

SHERPA. Connection Systems; Company. Source: <http://en.sherpa-connector.com/company;>

Stoutjesdijk P. (2013). Digital design & Digital fabrication for ultimate challenges. TU Delft thesis.

Tectonica. Tectonica Projects: Office Building in Dornbirn. Source: <http://www.tectonica-online.com/projects/41t70/>

University of Utah, College of Architecture + Planning. Interlocking CLT by Euclid Timber. Source: <http://itac.utah.edu/ICLT.html>

United Nations Environment Programme. (2007). Buildings And Climate Change: Status, Challenges and Opportunities. Source: from <http://www.unep.fr/shared/publications/pdf/DTIx0916xPA-BuildingsClimate.pdf>

United Nations Environment Programme. Life Cycle Assessment. Source: <http://www.unep.org/reSourceefficiency/Consumption/StandardsandLabels/MeasuringSustainability/>

Vacca Phil. (2009). LP SolidStart Engineered Wood Products and Formaldehyde Emissions. Source: http://www.lpcorp.com/ReSources/Literature/SolidStart_Rim_Board/Green_Briefs/LP_EWP_Formaldehyde_Emissions/

Wood design & building magazine. (2012-13). LCT ONE: winter 2012-13, pp:26; retrieved from http://www.creebuildings.com/files/130129Wood_Design_BuildingLCT_ONE.pdf

XLam. Case studies: Projects: Lighter Footprint. Sources: <http://www.xlam.co.nz/system/files/web-editor/ForteTrendzJuly13.pdf>

Figure List	Page	
Figure 1	World population 1950–2050; source: http://www.census.gov/population/international/data/idb/worldpopgraph.php	7
Figure 2	Global energy use 1850 –2100; source: Stoutjesdijk P. (2013). Digital design & Digital fabrication for ultimate challenges. TU Delft thesis, pp: 8	7
Figure 3	Global average temperature and co2 concentration 2000–2100; source: Stoutjesdijk P. (2013). Digital design & Digital fabrication for ultimate challenges. TU Delft thesis, pp: 8	7
Figure 4	Material composites; source: Knaack U., Bilow M., Auer T., Hilderbrand L.(2011). Energy. Imagine 05 series. 010 Publishers. Rotterdam; pp29	9
Figure 5	Co2 storage and emissions from different materials; source: Kolb J. (2008). Systems in Timber Engineering: Load bearing Structures and Component Layers. Birkhauser. Basel; pp:19;	11
Figure 6	Timber composites; source: http://www.clt.info/fi/wp-content/uploads/sites/11/2014/05/05-Building-with-Cross-Laminated-Timber.pdf ; pp:3	14
Figure 7	Engineered timber surface properties; source: http://www.clt.info/fi/wp-content/uploads/sites/11/2014/05/01-Technical-folder-Stora-Enso-Building-Solutions-CLT.pdf ; pp:8–9	16
Figure 8	Timber charring principle; source: http://www.woodworks.org/download.php?file=152 ; pp: 133	20
Figure 9	Allowed heights of timber constructions depending on country; source: http://www.woodworks.org/download.php?file=152 ; pp:49	21
Figure 10	Transporting modules; source: http://wood-works.ca/wp-content/uploads/5-rune-abrahamsen-bergen-in-a-wood-construction-fever.pdf ; pp:22	26
Figure 11	Prefabricated bathroom; source: http://www.woodworks.org/wp-content/uploads/CLT-PATTERSON.pdf ; pp5	27
Figure 12	Assembly process; source: https://www.flickr.com/photos/creebyrhomborg/sets/72157632057638322/	30
Figure 13	Growth of clt usage in europe; source: http://www.timberqueensland.com.au/Docs/News%20and%20Events/Events/Andrew-Nieland_web.pdf ; pp:13	34
Figure 14	Clt world potential; source: http://www.woodworks.org/wp-content/uploads/2013-WSF-ATL-Collins.pdf ; pp26	35
Figure 15	Glulam assembly, joint fastening; source: SHERPA connector systems	36
Figure 16	Clt assembly, joint fastening; source: http://www.timberqueensland.com.au/Docs/News%20and%20Events/Events/Andrew-Nieland_web.pdf ; pp:26	36
Figure 17	Possible connections; source: http://www.clt.info/fi/wp-content/uploads/sites/11/2014/05/01-Technical-folder-Stora-Enso-Building-Solutions-CLT.pdf	37
Figure 18	Interlocking clt principle; source: http://www.woodsolutions.com.au/Blog/Interlocking-Cross-Laminated-Timber-ICLT	38
Figure 19	Wall composed entirely of timber products; source: http://www.woodarchitecture.se/stories/thinking-inside-the-box	38

Figure 20	Glulam system by shigeru ban; source: http://www.designboom.com/architecture/shigeru-ban-architecture-and-humanitarian-activities/	39
Figure 21	Prefabricated hybrid floor; source: http://www.forum-holzbau.ch/pdf/IHF_13_Danzig.pdf ; pp:10	42
Figure 22	Life cycle tower installations; source: http://www.creebuildings.com/files/CreeBrochure.pdf	43
Figure 23	Tilt-up assembly system, michael green; source: http://www.woodworks.org/download.php?file=152 ; pp:186	44
Figure 24	Fftt option 1; source: http://www.woodworks.org/download.php?file=152 ; pp:62,66	46
Figure 25	Fftt option 2; source: http://www.woodworks.org/download.php?file=152 ; pp:62,66	46
Figure 26	Fftt option 3; source: http://www.woodworks.org/download.php?file=152 ; pp:63,67	46
Figure 27	Fftt option 4; source: http://www.woodworks.org/download.php?file=152 ; pp:63,67	46
Figure 28	Building layers scheme by Lukas Lang; source: http://www.lukaslang.com/ru.html	48
Figure 29	Design for disassembly factors; source: Dordevic M. (2014); Design for disassembly:Construction systems and joining techniques; Master Thesis, Barcelona	49
Figure 30	End of life scenario in a building; source: http://eprints.qut.edu.au/2888/1/Crowther-RAIA-2005.PDF ; pp4	50
Figure 31	Sherpa connector; source: http://de.sherpa-connector.com/lockingscrews and http://de.sherpa-connector.com/products	55
Figure 32	Knapp megant connector; source: http://www.knapp-verbinder.com/microsites/en/megant-installation.html	56
Figure 33	Knapp ricon connector; source: http://www.knapp-verbinder.com/microsites/en/ricon.html	57
Figure 34	Knapp gigant connector; source: http://www.knapp-verbinder.com/index.php?page=shop.product_details&flypage=flypage.tpl&product_id=375&category_id=45&option=com_virtuemart&Itemid=198&lang=en	57
Figure 35	Life cycle tower cross section; source: http://inhabitat.com/lifecycle-tower-in-austria-will-be-worlds-tallest-wooden-building/	63
Figure 36	Lct assembly scheme; source: http://www.creebuildings.com/files/CreeBrochure.pdf ; pp8	64
Figure 37	Clt axonometric display; http://www.tectonica-online.com/projects/41t70/ ; pp:19	64
Figure 38	Prefabricated facade with glulam columns; source: http://www.tectonica-online.com/projects/41t70/ ; pp15	65
Figure 39	Fitting of wood-concrete composite slab; source: http://www.tectonica-online.com/projects/41t70/ ; pp:15	65
Figure 40	Assembly of facade panels; source: http://www.tectonica-online.com/projects/41t70/ ; pp:15	65
Figure 41	Life cycle tower exterior; source: https://www.flickr.com/photos/creebyrhomburg/sets/72157632524547513/	66

Figure 42	Life cycle tower floor plan; source: http://www.detail.de/architektur/themen/erstes-holz-hybrid-hochhaus-in-dornbirn-003391.html	66
Figure 43	Life cycle tower 3d axonometry; source: http://www.tectonica-online.com/projects/41t70/ ; pp:19	67
Figure 44	Tamedia in construction phase; source: http://www.tamedia.ch/en/media-centre/photo-gallery/zurich-werdstrasse-new-building-during-construction/	69
Figure 45	Transportation of elements; source: http://www.tamedia.ch/en/media-centre/photo-gallery/zurich-werdstrasse-new-building-during-construction/	70
Figure 46	Glulam joints; source: http://www.blumer-lehmann.ch/fileadmin/documents/10_Unternehmen/142_In-den-Medien/056_061_BOH_Tec_Blumer_cf.pdf	70
Figure 47	Tamedia interior; source: http://www.tamedia.ch/fileadmin/files/images/neubau_werd/Tamedia_Grundrisse_Anischten_Shigeru_Ban_2.pdf	71
Figure 48	Tamedia section detail; source: source: http://www.tamedia.ch/fileadmin/files/images/neubau_werd/Tamedia_Grundrisse_Anischten_Shigeru_Ban_2.pdf	72
Figure 49	Tamedia section full height; source: http://www.tamedia.ch/fileadmin/files/images/neubau_werd/Tamedia_Grundrisse_Anischten_Shigeru_Ban_2.pdf	73
Figure 50	Tamedia floor plan; source: http://www.tamedia.ch/fileadmin/files/images/neubau_werd/Tamedia_Grundrisse_Anischten_Shigeru_Ban_2.pdf	73
Figure 51	Treet building 3d realisation; source: http://www.skyscrapercity.com/showthread.php?t=716272	75
Figure 52	Treet building external load bearing system; source: http://forumholzbau-nordic.com/assets/bilder/Presentations/Abrahamsen_Worlds_tallest_Bergen.pdf	76
Figure 53	Treet building clt core shaft; source: http://www.woodworks.org/download.php?file=152 ; pp: 165	76
Figure 54	Treet building interior; source: http://wood-works.ca/wp-content/uploads/5-rune-abrahamsen-bergen-in-a-wood-construction-fever.pdf ; pp: 52	77
Figure 55	Treet building assembly; source: http://statisk.bt.no/gfx/Treet/index.html	79
Figure 56	Forte building; source: http://www.forteliving.com.au/index.html	81
Figure 57	Rain screen facade ; source: http://www.woodworks.org/wp-content/uploads/2013-WSF-ATL-Collins.pdf ; pp57	82
Figure 58	Forte construction process; source: http://www.timberqueensland.com.au/Docs/News%20and%20Events/Events/Andrew-Nieland_web.pdf ; pp:25	83
Figure 59	Forte apartments, 3d realisation; source: http://www.treehugger.com/green-architecture/tallest-timber-apartment-building-opens-australia.html	83
Figure 60	Attitude towards timber	84
Figure 61	Ecoboard prototype; Pieter Stoutjesdijk, Press_Kit_Econnect pictures	87
Figure 62	Disaster shelter project joint principle; Pieter Stoutjesdijk, Press_Kit_Econnect pictures	88