



# DIPLOMARBEIT

## “Comparative analysis of optimisation methods for optimal sizing of stand-alone hybrid energy systems”

ausgeführt am Institut für  
Wirtschaftsmathematik  
der Technische Universität Wien

unter der Anleitung von  
Ao.Prof. Dr. Gernot Tragler

durch  
Judith Fechter  
Nappersdorf 7  
2023 Nappersdorf-Kammersdorf

23. Oktober 2014

## **Ehrenwörtliche Erklärung**

Ich versichere, dass ich die eingereichte Diplomarbeit selbstständig verfasst, andere als die angegebenen Quellen und Hilfsmittel nicht benutzt, und mich auch sonst keiner unerlaubten Hilfsmittel bedient habe. Ich erkläre weiters, dass ich die eingereichte Diplomarbeit weder im Inland, noch im Ausland in irgendeiner Form als wissenschaftliche Arbeit veröffentlicht habe.

Wien, Oktober 2014

Judith Fechter

## Danksagung

Ich möchte mich an dieser Stelle bei all jenen Personen bedanken, die mich bei der Erarbeitung dieser Diplomarbeit unterstützt haben. Mein herzlicher Dank gilt Herrn Prof. Dr. Gernot Tragler, dem Betreuer meiner Arbeit. Durch seine große Begeisterung für das Forschungsgebiet der Optimierung und durch seine zahlreichen Publikationen, sowohl im theoretischen, als auch im angewandten Kontext, hat er mein Interesse an diesem Gebiet verstärkt, weshalb ich diesen Themenbereich der Mathematik für meine Diplomarbeit gewählt habe.

Ein großes Dankeschön gilt meinen Eltern und meinen Geschwistern. Sie haben mir nicht nur das Studium finanziell ermöglicht, sondern mich auch in schwierigen Zeiten unterstützt und durch ihre kritischen Anmerkungen und durch ihre intra- und interdisziplinären Denkanstöße und Forderungen einen großen Teil zu meiner Entwicklung beigetragen.

An dieser Stelle möchte ich auch die Korrekturleserin und Korrekturleser Mag. Karin Fechter und Dr. Lukas Scagnetti dankend erwähnen, welche sich meiner Arbeit sehr gewissenhaft angenommen haben.

Abschließend möchte ich mich bei meinem Freundeskreis und meiner Kollegenschaft bedanken. Durch meine Freunde und Freundinnen war es mir stets möglich, die Studienzeit zu genießen und den Spaß an der Weiterbildung zu behalten.

Herzlichen Dank,

Judith Fechter

## **Abstract**

As a result of environmental pollution, increasing energy prices and technological progress, renewable power generation has gained in importance. Renewable energy sources have proved to be a reasonable alternative to fossil fuels. Especially in rural areas with scattered settlements it can be cost-intensive to meet the demand for energy in a reliable way. Hence, stand-alone hybrid energy systems have become very popular. This master thesis analyzes and compares optimisation techniques for the optimal design of a hybrid energy system. For this purpose three papers are examined and compared with respect to efficiency and speed. The discussed papers feature an iterative method, quadratic programming and dynamic programming as the chosen mathematical methods. As a result of the comparison, parameters for choosing the best possible optimisation technique are presented.

keywords: *optimisation, renewable energy, hybrid energy system*

# Contents

<b>1</b>	<b>Introduction</b>	<b>7</b>
<b>2</b>	<b>Renewable Energy</b>	<b>10</b>
<b>3</b>	<b>Hybrid Energy Systems</b>	<b>17</b>
3.1	Classes of Hybrid Energy Systems . . . . .	18
3.1.1	Hybrid Energy Systems with Battery Storage . . . . .	18
3.1.2	Hybrid Energy Systems with Battery Storage and Hydrogen Tank . . . . .	19
3.2	Modelling of a Hybrid Energy System . . . . .	20
3.2.1	Photovoltaic System . . . . .	20
3.2.2	Wind Energy System . . . . .	22
3.2.3	Micro Hydro System . . . . .	24
3.2.4	Battery Storage System . . . . .	25
3.2.5	Diesel Generator . . . . .	27
3.3	Criteria for Optimal Sizing . . . . .	28
3.3.1	Minimising Operational Costs . . . . .	28
3.3.2	Minimising Life Cycle Costs . . . . .	29
3.3.3	Minimising Levelled Costs of Energy . . . . .	30
3.3.4	Maximising Profit . . . . .	30
<b>4</b>	<b>Mathematical Models for Solving the Problem of Optimal Sizing</b>	<b>32</b>
4.1	Non-Linear Programming . . . . .	33
4.1.1	Problem Formulation . . . . .	33

4.1.2	Algorithmic Procedure . . . . .	37
4.1.3	Properties of the Optimisation Problem . . . . .	38
4.2	Quadratic Programming . . . . .	39
4.2.1	Problem Formulation . . . . .	39
4.2.2	Properties of the Optimisation Problem . . . . .	41
4.3	Mixed Integer Linear Programming . . . . .	42
4.3.1	Problem Formulation . . . . .	42
4.3.2	Properties of the Optimisation Problem . . . . .	44
4.3.3	Extension of the Problem . . . . .	46
<b>5</b>	<b>Comparative Analysis</b>	<b>50</b>
5.1	Characteristics of Considered Cites . . . . .	50
5.2	Results . . . . .	53
5.2.1	Results of the Iterative Method . . . . .	53
5.2.2	Results of Quadratic-Programming . . . . .	54
5.2.3	Results of Mixed-Integer-Programming . . . . .	56
<b>6</b>	<b>Summary</b>	<b>58</b>
6.1	Choice of Renewable Sources . . . . .	58
6.2	Choice of Optimisation Technique . . . . .	60
6.3	Choice of Constraints . . . . .	62
6.4	Conclusion . . . . .	63
	<b>Bibliography</b>	<b>66</b>

*“In most sciences one generation tears down what another has built, and what one has established, another undoes. In Mathematics alone each generation adds a new storey to the old structure.”*

**Hermann Hankel**

German mathematician; 1839–1873.

# Chapter 1

## Introduction

In recent years renewable energies have developed rapidly. This is not only due to the awareness of the exhaustibility of fossil fuels and the risks inherent in atomic power, but is also due to an increasing environmental awareness and the known fact that climate change is caused by carbon emissions into the atmosphere [Nasa, 2014].

Renewable energy sources are either integrated into an existing grid, or autonomous systems are built to provide energy to an object or area which is not connected to the grid. Such autonomous systems can be useful in remote areas, like islands or very distant villages. Hybrid energy systems, that is systems which integrate different power sources, serve this purpose best as they can provide energy reliably. The undertaking of building hybrid energy systems has also posed new challenges for the field of optimisation in so far as either the operating strategy or the sizing process have to be optimised, both of which being essential factors for making a system economically feasible. Various aspects must be considered. Two of the main aspects are the system costs and the reliability. Hybrid systems are more reliable than systems which generate power using just one energy source [Dufo-López et al., 2007]. Another advantage is that they can be designed in various different ways depending on climate and demand. From a mathematical point of view the task of designing includes a large number of variables which makes



the task complicated [Seeling–Hochmuth, 1997]. Different authors have approached the designing problem in various ways.

[Yang et al., 2007] apply an iterative technique to develop a model for Hybrid Solar–Wind System Optimization Sizing. The aim is to size the capacity of the different components of the system optimally. The model employs the model of Loss of Power Supply Probability, the model of the Levelised Cost of Energy and the model of the Hybrid Energy System. [Chedid, Saliba, 1998] use a linear–programming approach for minimising the average costs for generating energy, taking account of the demand– and reliability requirements. [Cai et al., 2009] apply Interval–Linear Programming, Chance–Constrained Programming and Mixed–Integer–Linear Programming to build a framework, which allows to incorporate uncertainties, like probability distributions and interval values, and to facilitate capacity–expansion planning while minimising costs and maximising reliability. The approach of [De, Musgrove, 2007] consists of a Stochastic Dynamic Programming model, RAPSODY. This model determines optimal operating strategies for a hybrid energy system. It analyzes the average daily costs of satisfying the power demand. It takes fuel–, investment–, operating–, and maintenance costs into account.

This master thesis bears upon [Ashok, 2007], [Billionnet et al., 2014] and [Tazvinga et al., 2013]. [Ashok, 2007] uses an iterative method for sizing a hybrid energy system. The technical facts of the single components as well as the power output and the energy demand are assumed to be known. Three renewable sources can be integrated, also a battery system and a diesel generator. The aim is to find a reliable system with minimised unit energy costs.

[Billionnet et al., 2014] consider a Mixed–Integer–Linear Programming method, approached as a two–stage problem. For the second stage a Dynamic Programming algorithm is developed. The results for the optimisation problem when using Dynamic Programming are compared to

the achieved results when using a standard solver with regard to two renewable sources as well as a battery system and a diesel generator. The aim is to find a reliable system with minimised total costs.

[Tazvinga et al., 2013] make use of a Quadratic Programming approach with the aim of finding an optimal operating strategy for an existing hybrid energy system. The system was designed using a simple spreadsheet method [Tazvinga, Hove, 2012]. It incorporates one renewable source, a battery system and a diesel generator. The objective is to achieve minimal operating costs.

The goal of this master thesis is to achieve essential results for economic applications of hybrid energy systems by comparing the papers introduced above. The main reason for discussing those papers lies in the fact that they are using different optimisation methods, while only considering renewable sources, a battery system and a diesel generator. All three papers describe systems for remote areas, providing the energy demand of a village. The aim is to discuss the accuracy of the results, the efficiency of the considered algorithms and some recommendable further work.

This thesis is organised as follows. The 2nd chapter talks about renewable sources in general, and leads into the discussion of energy- and political standards in Austria. The 3rd chapter introduces hybrid energy systems, in particular the mathematical modelling of the single components as well as the most common criteria for optimising hybrid energy systems. The 4th chapter discusses three optimisation models in detail. The 5th chapter considers the characteristics of the sites discussed in the above mentioned papers as well as the results of each optimisation model. The last chapter draws a conclusion regarding the choice of renewable sources and the optimal choice of the optimisation method.

## Chapter 2

# Renewable Energy

In 2010, the energy import dependency of the European Union amounted to 56% and is estimated to increase till 2030 to 67% [EC, 2014]. In 2013, 41% of the imported natural gas was imported from Russia [Pongas et al., 2014]. This means a strong dependence on one country. Using fossil fuels does not only implicate a risk of economical dependence, but also a high impact on climate conditions. A comparison of renewable energies and fossil fuels shows that the use of renewable energies has a lot of advantages: wind-, solar- or hydrokinetic systems do not implicate any air pollution. Further they do not require any additional water for operating. Hence, neither are water resources polluted nor agricultural- or drinking water systems influenced. In contrast with this are fossil fuels, which can have an adverse effect on water resources. Not only can natural gas drilling or coal mining pollute drinking water sources, but also the extraction of natural gas by hydraulic fracturing requires large amounts of water and so do all thermal power plants, which require tons of water for cooling [UCSUSA, 2014].

With technological progress the costs for renewable energy have decreased steadily. For example, the average system price for an installed rooftop solar system of up to 100 kW has decreased by 60% from 2006 to 2012 [Energiewende, 2014]. Also the costs for generating wind energy have decreased by more than 20% between 2010 and 2012 and more than 80%

since 1980. Due to the fact that the operating costs are low once the facilities are built, the energy prices are relatively stable over long time [UCSUSA, 2014], while energy prices for fossil fuels can vary greatly and are contingent on economical development [?].

Already faced with the consequences of climate change and increasing import dependence, the EU has committed to “binding targets” [EC, 2014], which state:

- reducing greenhouse–gas emissions by 20%,
- increasing the share of renewable energies to 20% of total EU energy consumption,
- increasing the share of renewable energies in transport to 10% and
- improving energy efficiency by 20%.

Those targets seem reasonable as the development of renewable energies will have an essential impact on society. The percentages are average values in regard to the EU in general. The targets are determined individually for each country depending on their wealth [EC, 2014].

Germany takes a pioneering role when it comes to implementing measures for producing energy by renewable sources. The share of supplied electricity generated by renewable sources increased from 6,3% in 2000 to 31% in the first half of 2014 [Winter, 2014]. While electricity production by uranium, gas, brown– and hard coal reported a drop, production by wind, solar and biomass experienced an upswing when comparing the first half of 2013 with the first half of 2014 [Kroh, 2014]. Germany is also one out of six European countries (beside Spain, France, Great Britain, Italy, Malta) that produce more than 5000 MW of supplied electricity by wind power. In comparison Austria produced 1684 MW by wind power in 2013 [IGWindkraft, 2014].

The potential of renewable energy in Austria will be discussed in the following section.

## Renewable Energies in Austria

In 2011 Austria was dependent on energy imports by 70,1% in order to meet its energy demands. In 2012 the energy dependency came to 63,6%. From 2001 to 2012 Austria's energy dependency amounted to 62,2–72,3%. Compared to the other EU states Austria is above average, which is in the range of 47,4–54,7% from 2001 to 2012 [Eurostat, 2014]<sup>1</sup>. In 2010 the share of imported energy was 85,4%, in 2011 it was 90,3% of the gross inland energy consumption [Bointner, 2013]. A large share of energy is imported from Germany, followed by the Czech Republic. Since 2001 the energy imports have exceeded the exports of energy in order to meet the demands [Umweltbundesamt, 2014]. In 2011 the demand was met by providing 69,4% fossil fuels, 28,6% renewable energies [Bointner, 2013]. A closer look at energy produced in Austria shows that most of it is hydrokinetic energy. From 2007 onwards the share of hydroelectricity was steadily increasing from 52,72% to 65,26% in 2012, with the exception of 2011 (56,13%) due to low water quantity, followed by natural gas with a mere 13,22% and coal with 4,66% in 2012. Wind power, another renewable source, accounted for 4,29% [EControl, 2013].

A research group of the Vienna University of Technology dealt with the question: “Can the Austrian electricity demand be fully covered by renewable generation, and if so, how?”. The report [Boxleitner et al., 2011] shows very interesting results. For the purpose of answering the question, whether the Austrian power demand can be fully met by renewable energy, the potential of renewable sources was investigated.

The potential of hydrokinetic energy was calculated based on the data on water flows from 1976–2006<sup>2</sup>, depicted in Figure 2.1.

---

<sup>1</sup> percentage results from net imports divided by the sum of gross inland consumption of energy

<sup>2</sup> based on an underlying digital terrain model and on the basis of interpolated water flows, differences in altitude from the beginning to the end of one water segment were calculated

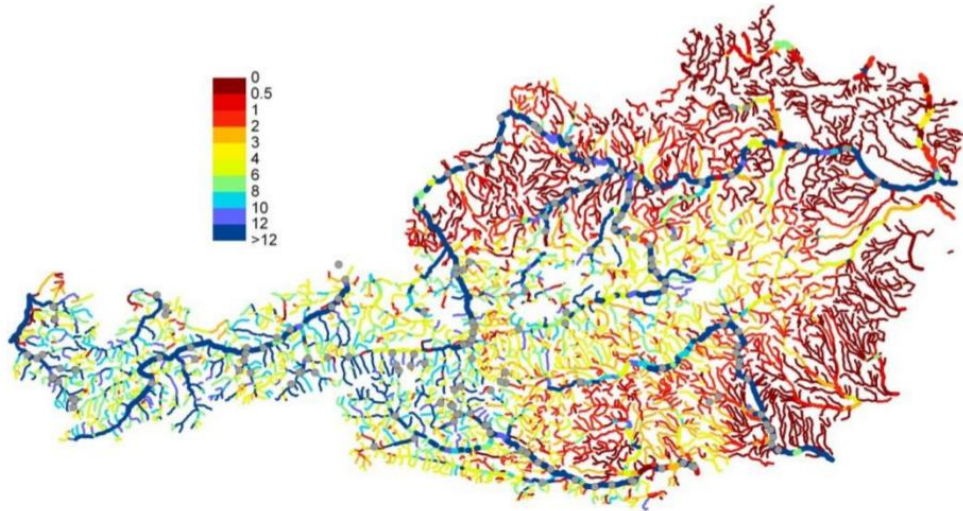

Figure 2.1: Potential of hydropower in Austria [Boxleitner et al., 2011]

The Danube region in Upper Austria has the highest potential of hydrokinetic energy, and the lowest seasonal variation is observed in that region too. On the other hand a wide range of variation between summer and winter can be observed in the Alpine regions. Due to the disparity in seasonal water flows the energy extraction can be reasonably interchanged between the regions.

Wind power has developed rapidly in Austria. While in 2000 only 77 *MW* wind power were produced, the output increased to 966 *MW* in 2006 and even to 1684 *MW* in 2013. For 2014 a power output of 2064 *MW* is projected [IGWindkraft, 2014]. The above mentioned report [Boxleitner et al., 2011] investigated the potential of wind power under technical–juridical restrictions.<sup>3</sup> The results can be seen in Figure 2.2. The coloured areas show the regions with potential for generating wind power, allowing for technical– as well as juridical requirements.

<sup>3</sup> restrictions of spatial use, altitude (2000 m above sea level), hills, buffer zones, conservation area, minimum size requirements

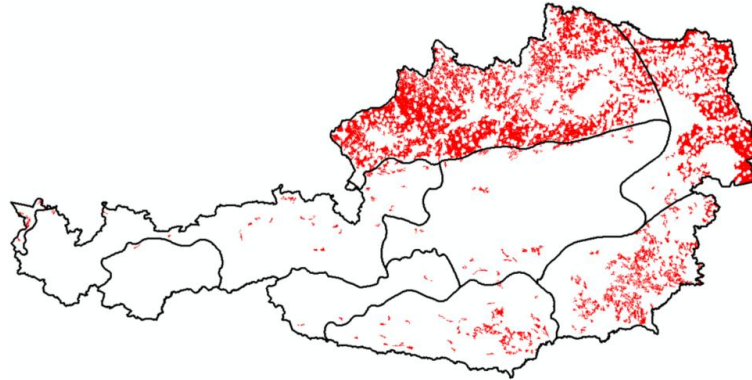

Figure 2.2: Potential of wind power in Austria [Boxleitner et al., 2011]

Under further restrictions, like those imposed by farming areas, the calculated area for producing wind energy is around  $1000 \text{ km}^2$ , which accounts for around 1.2% of the Austrian state.

The results can be verified by comparing the potential areas with areas already occupied by wind generators. Figure 2.3 shows operating wind farms and their output.

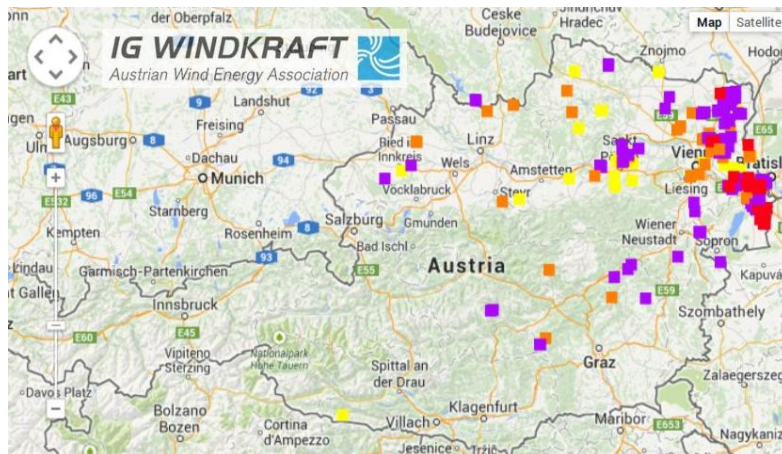

Figure 2.3: Installed wind generators in Austria [IGWindkraft, 2014]

The colour represents the plant system rating of a windpark: yellow: 0–

500kW, orange: 500kW–1MW, violet: 1MW–2,5MW, red: >2,5MW.

For calculating the potential area for producing energy by solar power, the restrictions summarized in table 2 must be considered.

Table 2.1: Limiting values for PV-systems [Boxleitner et al., 2011]

insolation p.a.	> 1885
hillslope south	< 20°
hillslope west-east	< 5°
sealevel	< 2000m

Figure 2.4 shows the potential of solar power in Austria under the above mentioned restrictions. Green coloured areas are agricultural areas, red coloured areas are cultivated areas.

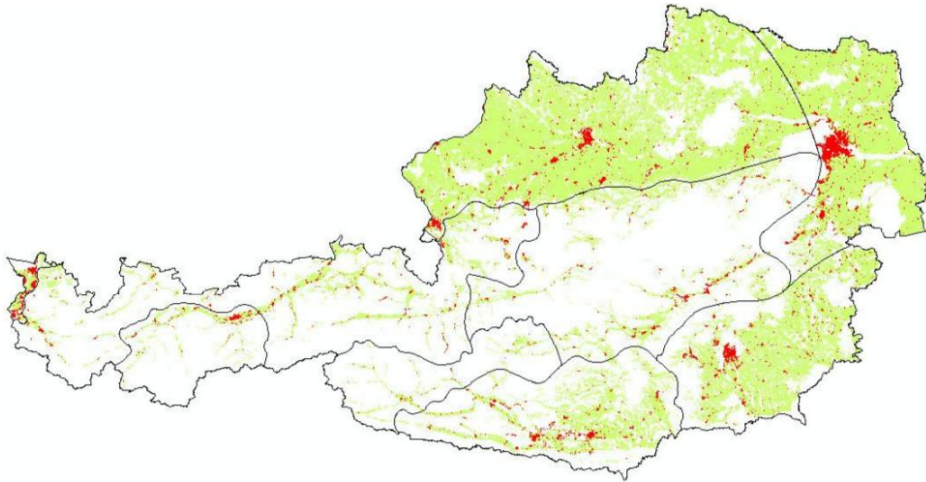

Figure 2.4: Potential of solar power in Austria [Boxleitner et al., 2011]

The potential cultivated area is around 3272 km<sup>2</sup>, the potential agricultural area around 26221 km<sup>2</sup>. Regarding restrictions, like architectural suitability, module efficiency, space for accessory or insolation,



the potential power output of cultivated areas is estimated as 23 *GW* (17 *GW* rooftops, 6 *GW* frontage) per annum. The average power output of agricultural areas is estimated as 24 *GW/km<sup>2</sup>* per annum [Boxleitner et al., 2011].

The above discussed report [Boxleitner et al., 2011] outlines that Austria has suitable geographic and climatic conditions for satisfying the Austrian energy demand with 100% renewable energy. One of the EU targets for Austria says that 34% of the supplied electricity must be produced by renewable sources. In 2010 the share of renewable energy was 31%. Furthermore Austria committed itself to reduce greenhouse gas emissions in sectors which do not underlie emission trading by 16%. Another target is to increase energy efficiency by 20% [Umweltbundesamt, 2014].

## Chapter 3

# Hybrid Energy Systems

The term “Hybrid Energy System” describes a dynamic system which integrates different energy sources as well as storage systems. Renewable energy systems, like solar-panels, wind-generators or hydrokinetic-turbines are interconnected via a battery storage or a diesel generator to satisfy the given energy demand at any time [Gupta et al., 2011]. One advantage of connecting different systems is that performance reliability is improved. Further on, the size of the storage system can be reduced since performance is less dependent on a single source of energy [Supriya, Siddarthan, 2011].

In the following Section 3.1 two classes of hybrid energy systems are introduced. Section 3.2 discusses the modelling of the single components. Since the constraints of an optimisation problem are the direct result of the modelling process, modelling is an essential and necessary task. Obviously the more accurate the constraints are, the more exact is the solution. At the end of this chapter some criteria for optimal sizing are quoted with a view to the discussion of the practical application of three optimisation methods in Chapter 4.

### 3.1 Classes of Hybrid Energy Systems

The following sections introduce two differently assembled stand-alone hybrid energy systems. Integrated in both of the systems considered here is a battery storage system, a charge regulator, a diesel generator as well as an AC (alternate current) and DC (direct current) load. Also an inverter is needed because renewable sources and fuel cell power systems generate power in DC form, which must be converted to AC [Mehrpooya, Daviran, 2013]. Hybrid energy systems differ depending on the integrated energy sources, like wind-, solar- or hydropower, as well as by integrating either a hydrogen tank, an electrolyser or a fuel cell. Due to the intermittent power generation using renewable sources, the main aspects of the optimal sizing of hybrid energy systems consist of satisfying the power demand in a reliable way as well as minimizing costs [Koutroulis et al., 2006].

#### 3.1.1 Hybrid Energy Systems with Battery Storage

In this section we consider hybrid energy systems which are composed of various renewable energy sources, a battery storage and a diesel generator. Such a system is shown in Figure 3.1.

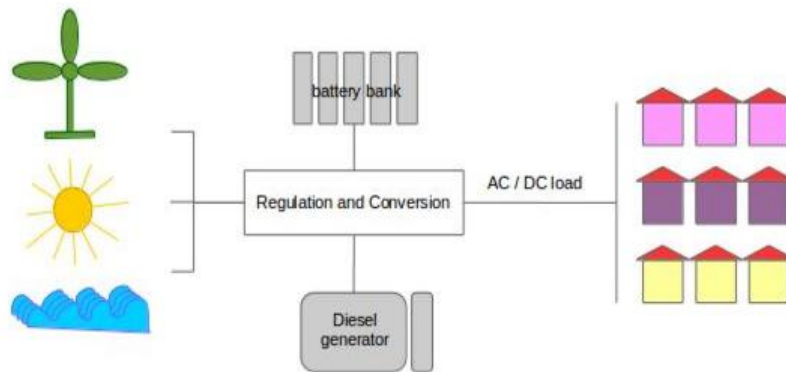

Figure 3.1: Hybrid Energy System with battery storage

When the weather conditions are advantageous, so that more energy is

produced by renewable sources than required, the battery storage will be loaded. In case of producing less energy than required, the demand can be served by either the battery storage or the diesel generator. However, the diesel generator will only be used when the battery storage is empty as the costs of using it are very high [Billionnet et al., 2014]. The discussed papers (see Chapter 4) proceed on the assumption that the diesel generator does not charge the battery.

In this thesis we only consider hybrid energy systems with battery storage as they are more common. Systems with hydrogen tanks are not economically viable due to the high investment costs for fuel cells and the low efficiency of electrolyzers in converting electricity to hydrogen and back to electricity [Bernal–Agustín, Dufo–López, 2009]. For the sake of completeness the following section also quotes systems which additionally integrate a hydrogen tank.

### **3.1.2 Hybrid Energy Systems with Battery Storage and Hydrogen Tank**

This section describes hybrid energy systems which integrate a hydrogen tank, an electrolyser as well as a fuel cell. If more energy is produced by renewable sources than required, the spare energy can be either used for charging the battery storage or for the hydrogen production in the electrolyser. The hydrogen can be used for charging the fuel cell. However, the fuel cell can also be charged by externally purchased hydrogen [Dufo–López et al., 2007]. Such a system is illustrated in Figure 3.2.

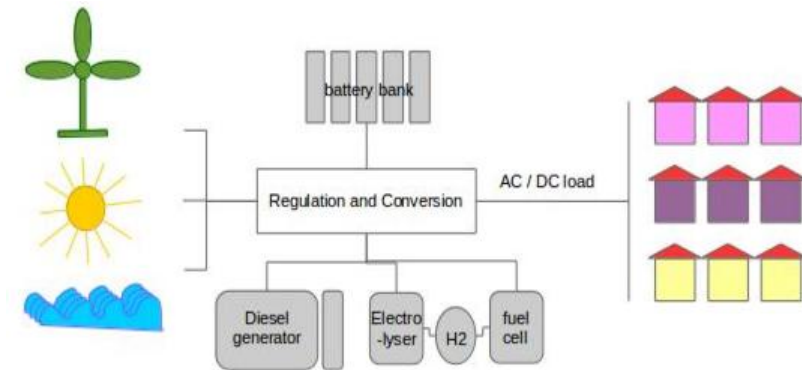

Figure 3.2: Hybrid Energy System with battery storage and H2 tank

## 3.2 Modelling of a Hybrid Energy System

In this section we propose an approach for mathematical modelling of the single components of a hybrid energy system. As mentioned before the modelling process is an important prestage in the formation of an optimisation problem as the constraints are derived from the mathematical modelling. In this section we propose simplified models of components, which are integrated in the optimisation models discussed in Chapter 4.

### 3.2.1 Photovoltaic System

Photovoltaics (PV) is a technology that generates electrical power by converting solar energy into DC electricity. Power is generated by solar panels which consist of a number of solar cells. Solar cells convert sunlight into a flow of electrons. When photons are absorbed by a solar cell, their energy is transferred to an electron. Electrons associated with an atom can be used as charge carriers for an electric current. Solar cells generate direct current (DC) electricity [Thomas, 2008]. DC electricity must then be converted into AC electricity inside the hybrid energy system, since the energy in demand must be supplied as AC load.

Photovoltaic cells are made of mono-crystalline silicon, poly-crystalline silicon or amorphous silicon [Pearce, 2002]. To meet the load demand, PV-panels are connected. The total number of connected panels is determined by the DC load of the system, whereas the total area of the PV-system describes the power output of the system [Yang et al., 2007].

In a first step we estimate the total solar irradiation on an inclined surface  $SR_t$  (kWh/m<sup>2</sup>) following [Deshmukh, Deshmukh, 2008]:

$$SR_t = SR_n * \sigma_n + SR_d * \sigma_d + (SR_n + SR_d) * \sigma_r$$

with:

$SR_n, SR_d$  ... direct solar radiation, diffuse solar radiation,  
 $\sigma_n, \sigma_d, \sigma_r$  ... normal, diffuse, reflected tilt factors.

The power output  $P_j$  per hour on an average day of  $j^{th}$  month can be expressed as [Deshmukh, Deshmukh, 2008]:

$$P_j = SR_t * A_{PV} * \eta$$

with:

$A_{PV}$  ... total area of PV-modules (m<sup>2</sup>),  
 $\eta$  ... system efficiency [Deshmukh, Deshmukh, 2008] [Habib et al., 1999],  
 where:

$$\eta = \eta_{pc} * P_f * \eta_m$$

with:

$\eta_{pc}$  ... power conditioning efficiency, if a perfect maximum power tracker is used it is equal to 1 [Kaabeche et al., 2010],  
 $P_f$  ... packing factor,  
 $\eta_m$  ... module efficiency defined as:

$$\eta_m = [1 - \beta * (T_c - T_r)] * \eta_r$$

with:

$\eta_r$  ... module reference efficiency,

$\beta$  ... generator efficiency temperature coefficient which is assumed to be constant (for silicon cells: 0,004–0,006) [Kaabeche et al., 2010],  
 $T_r$  ... reference temperature for the cell efficiency ( $^{\circ}\text{C}$ ),  
 $T_c$  ... monthly average cell temperature ( $^{\circ}\text{C}$ ) with:

$$T_c = T_a + \frac{NOCT - T_{a,NOCT}}{SR_{t,NOCT}} * SR_t$$

Since  $T_{a,NOCT}$  can be estimated as  $20^{\circ}\text{C}$  and  $SR_{t,NOCT}$  estimated as  $800 \text{ W/m}^2$ , for a wind speed of  $1 \text{ m/s}$  [Deshmukh, Deshmukh, 2008], we achieve:

$$T_c = T_a + \frac{NOCT - 20}{800} * SR_t$$

with:

$T_a$  ... ambient temperature ( $^{\circ}\text{C}$ ),  
 $NOCT$  ... nominal cell operating temperature ( $^{\circ}\text{C}$ ).

The parameters  $\eta, \eta_{pc}, \beta, A$  and  $NOCT$  depend on the type of the PV-module in use and must be obtained from the manufacturer [Kaabeche et al., 2010].

### 3.2.2 Wind Energy System

Wind energy systems are composed of wind turbines. A wind turbine is a device which converts kinetic energy into electrical energy. The wind turns the blades, which in turn spin a shaft. If this is connected to a generator, electricity is produced [Energy 101, 2014]. The power output depends on the wind speed distribution for a selected site. Due to that fact, characteristics of wind energy systems, like site, type of turbines and hub height, must be taken adequately into account [Kaabeche et al., 2010]. Wind speed at hub height can be calculated by using the power-law equation [Deshmukh, Deshmukh, 2008] [Kaabeche et al., 2010]:

$$V(H) = V(H_{ref}) * \left( \frac{H}{H_{ref}} \right)^{\alpha}$$

with:

$H, H_{ref}$  ... hub height and reference height,

$V(H), V(H_{ref})$  ... wind speed at hub height and reference height ( $m/s$ ),  
 $\alpha$  ... power-law exponent. The value of  $\alpha$  depends on the specification  
of the selected site. If no site-specific data exist,  $\alpha$  is mostly estimated  
as  $1/7$ .

The power output  $P_W$  ( $kW/m^2$ ) of a wind turbine can be considered as  
[Deshmukh, Deshmukh, 2008]:

$$\begin{aligned} P_W &= 0, & V &\leq V_{ci} \\ P_W &= aV^3 - bP_r, & V_{ci} &\leq V \leq V_r \\ P_W &= P_r, & V_r &\leq V \leq V_{co} \end{aligned}$$

with:

$P_r$  ... rated power,

$V_{ci}, V_{co}, V_r$  ... cut-in, cut-out and rated speed of the wind turbine,

$$a = P_r / (V_r^3 - V_{ci}^3),$$

$$b = V_{ci}^3 / (V_r^3 - V_{ci}^3).$$

The power output of a wind turbine can be estimated as [Chedid et al., 1998]:

$$P = P_W * A_W * \eta$$

with:

$A_W$  ... total swept area,

$\eta$  ... efficiency of wind turbine generator and corresponding converters.

Figure 3.3 shows the relation between wind speed and power output.



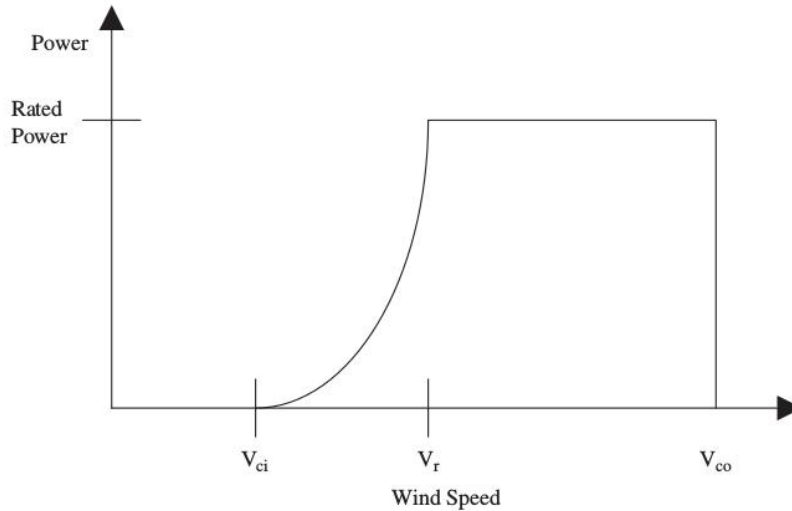

Figure 3.3: Wind speed to power output [Deshmukh, Deshmukh, 2008]

### 3.2.3 Micro Hydro System

Micro hydro power is a type of hydroelectric power that generates electricity by using some natural flowing water body. The energy is derived from running or falling water, which is used to turn the blades of a turbine. The turbine is connected to a generator that converts the mechanical energy into electricity [Pembina Institute, 2014].

Two basic types of hydropower systems can be distinguished: those that use dammed up water and those that use a channel running parallel to a river. Both systems feature a vertical pipe that transports water to the turbines. Hence both systems can quickly respond to a varying demand by releasing and diverting more water. During periods of low power demand dam systems can keep back water for peak periods. However, systems installed parallel to a river have a lower impact on the environment since the flow direction, the riverbed and hence the aquatic life is less affected than when damming water [Pembina Institute, 2014].

Following [Mostofi, Shayeghi, 2012] the potential of generated power is calculated as follows:

$$P_{total} = P_h * \eta_g * \eta_t$$

where:

$P_h$  ... hydraulic power,

$\eta_g$  ... generator efficiency,

$\eta_t$  ... turbine efficiency.

The power output depending on the turbine location can be estimated as follows:

$$P_h = C_w * \rho_e * g * h_f$$

with:

$C_w$  ... water density,

$\rho_e$  ... coefficient of electrical discharge,

$g$  ... gravitational acceleration,

$h_f$  ... water head.

### 3.2.4 Battery Storage System

In periods of non-availability of renewable sources the energy demand must be met by using battery storage systems. As mentioned before the battery of a hybrid energy system is charged during periods of surplus production of renewable sources. Normally Pb-acid batteries are used for energy storage [Yang et al., 2007]. For an appropriate sizing of the battery storage the following requirements must be briefly analyzed: charge and discharge requirements of the battery, the efficiency of the charger and other components, pattern and output of the renewable sources and the operating temperature [Yang et al., 2007]. Operating the battery storage induces a loss of energy. This is taken into account by using a rate of return factor  $\gamma$  in the examined optimisation methods (see Chapter 4).  $\gamma$  is less than 1 and represents the percentage that can effectively be used when charging 1 kWh into the battery system [Billionnet et al., 2014]. The battery storage must be adequately sized

so that the energy demand can be provided in periods when no renewable sources are available. Such periods are referred to as days of autonomy [Deshmukh, Deshmukh, 2008]. The total capacity of the battery system can be estimated as [Kaabeche et al., 2010]:

$$C_B = \frac{E_l * SD}{V_B * DOD_{max} * \eta_t * \eta_B}$$

with:

$E_l$  ... electrical load ( $Wh$ ),

$SD$  ... number of storage days,

$V_B$  ... battery system voltage,

$DOD_{max}$  ... maximum battery depth of discharge,

$\eta_t$  ... temperature correction factor,

$\eta_B$  ... battery efficiency.

The state of charge ( $SOC$ ) depends on whether the demand is greater or less than the power supply by renewable sources. Hence the  $SOC$  can be expressed as the difference between the generated power and the power demand [Kaabeche et al., 2010]:

Charging process:

$$SOC_t = SOC_{t-1} * (1 - \sigma) + (E_{gen}(t) - E_l(t)/\eta_{inv}) * \eta_B$$

Discharging process:

$$SOC_t = SOC_{t-1} * (1 - \sigma) + (E_l(t)/\eta_{inv} - E_{gen}(t))$$

with:

$SOC_t, SOC_{t-1}$  ...  $SOC$  of the battery storage at time  $t$  and  $t - 1$  ( $Wh$ ),  
 $\sigma$  ... hourly self-discharge rate.  $\sigma$  depends on the current condition of the battery and the accumulated charge. The proposed average approximation is 0.02% [Yang et al., 2007].

$E_{gen}$  ... generated energy by renewable sources,

$E_l$  ... load demand,

$\eta_{inv}, \eta_B$  ... efficiency of inverter, charge efficiency.  $\eta_B$  is determined by the condition of the battery.

As a constraint the following equation [Deshmukh, Deshmukh, 2008] must be satisfied:

$$SOC_{min} \leq SOC(t) \leq SOC_{max}.$$

$SOC_{max}$  is determined by the nominal capacity of the battery storage  $C_B$ ,  $SOC_{min}$  can be expressed depending on the value of  $DOD$ , the maximum depth of discharge:  $SOC_{min} = (1 - DOD) * C_B$ . In most studies,  $DOD$  takes the value of 30%–50% as manufacturers say that the capacity can be prolonged to its maximum if the  $DOD$  is between 30%–50% [Kaabeche et al., 2010] [Yang et al., 2007].

### 3.2.5 Diesel Generator

A diesel generator consists of a diesel engine combined with an electric generator to produce electrical energy. If the power demand can not be met by either renewable sources or by the battery storage, the diesel generator is engaged so that the power demand can always be satisfied [Deshmukh, Deshmukh, 2008]. The choice of a diesel generator depends on the type and nature of the electric load. When specifying the capacity, the following cases should be considered [Notton et al., 1996] [Deshmukh, Deshmukh, 2008]:

- In the case of connecting the diesel generator to the load, the capacity should be modulated at least equal to the maximum load.
- In the case of charging the battery storage, the current production should not be greater than  $C_{amph}/5A$ , where  $C_{amph}$  denotes the ampere-hour capacity of the battery.

A diesel generator is usually designed to run between 80%–100% of the kW-rating while operating concurrently with renewable systems or the battery system [Kusakana, Vermaak, 2014]. However, it has been observed that operating at 70%–90% of full power is more economical [Hefnawi, 1998]. The power output can be expressed as:

$$DG = DG_{max} * X_{DG}$$

with:

$DG$  ... current output as a percentage of the maximum output,

$DG_{max}$  ... maximum nominal output,

$X_{DG} \in [0, 1]$  ... output decision variable. 0 means no output, 1 means maximum output.

### 3.3 Criteria for Optimal Sizing

An optimally sized hybrid energy system should not only meet the power demand. Also economical requirements must be satisfied. The analysis of costs is an important issue when it comes to the study of whether a hybrid energy system is economically feasible or not. In the following sections we will discuss different optimisation criteria for sizing a hybrid energy system. First we will consider three different types of costs whereby the lowest costs are usually preferred. Further, we will look at the profit of a company, another criterion when analysing economical feasibility. Profit is defined as the difference between the revenue of selling energy and the life cycle costs of an operating system, which must be maximised.

#### 3.3.1 Minimising Operational Costs

Operational costs are incurred while operating the system, like costs for fuel, operation and maintenance. Operating and maintenance costs can be neglected as they are proportionally low compared to the fuel costs. The fuel costs constitute the main part of the operating costs [Ashok, 2007]. [Kusakana, Vermaak, 2014] developed a Quadratic-Programming model for the optimal sizing of a hybrid energy system. The model is based on a description of current flows from different energy sources. They take into account the number of modules and the size of the renewable sources, as well as the operation control settings and strategies which influence the shifting between the diesel generator and the battery system. [Zhang, Li, 2011] present a Dynamic-Programming method for solving the optimal sizing problem.

### 3.3.2 Minimising Life Cycle Costs

Life cycle costs include, beside the operational costs, also costs of investment [Senyu et al., 2006]. In many papers it is assumed that the total costs are proportional to the number of PV-panels installed, wind turbines or hydrokinetic turbines [Ashok, 2007] [Billionnet et al., 2014] [Supriya, Siddarthan, 2011]. The maintenance costs,  $mC_S$ , can be assumed to be proportional to their squares [Supriya, Siddarthan, 2011]. Based on the mathematical model of PV-modules from [Supriya, Siddarthan, 2011], the initial costs,  $iC_S$ , of renewable sources can be generally expressed as follows:

$$iC_S = \frac{S_c * S_n}{S_T}$$

$$mC_S = \frac{S_c * (1 - \eta_S) * S_n^2}{S_T^2}$$

with:

$S_c$  ... cost per  $m^2$  of PV-panel, per one generator of wind- or hydrokinetic turbine,

$S_n$  ... number of panels or generators,

$S_T$  ... lifetime (in years) of panels or generators,

$\eta_S$  ... coefficient of reliability of panels or generators.

[Ashok, 2007] developed a model for designing a hybrid energy system with the objective of minimising life cycle costs. Based on the the examination of different system components, a general model is found for sizing the system's hardware and selecting operating options.

[Supriya, Siddarthan, 2011] propose a Quadratic-Programming approach for minimising costs of electricity production, while still making sure that the energy demand is met, and minimising the power purchased from the grid. [Tazvinga et al., 2013] propose a Quadratic-Programming method for minimising the total costs of a system. This paper is not about designing a hybrid energy system, only about minimising costs.

[Billionnet et al., 2014] examine different approaches to the optimal sizing of a stand-alone hybrid energy system. They compare a two-stage robust approach, a constraint generation algorithm with sub-problems reformulated as Mixed Integer Linear Programs as well as a Polynomial Dynamic Programming algorithm. The optimisation models of [Ashok, 2007], [Tazvinga et al., 2013] and [Billionnet et al., 2014] are examined in Chapter 4. They will be introduced, analyzed and compared with each other.

### 3.3.3 Minimising Levelled Costs of Energy

Another benchmark for economical feasibility are the levelled costs of a system. Levelled costs of energy are defined as the total costs of a hybrid energy system divided by the energy supplied by the system. They can be expressed as [Yang et al., 2007]:

$$lCE = \frac{\sum_{i=1}^n C_{S_i}/S_{T_i}}{E_{an}}$$

with:

$n$  ... number of components, which are PV-panels, wind- or hydrokinetic generators or a battery system,

$C_{S_i}$  ... sum of costs of investment, replacement or maintenance during the lifespan of the  $i^{th}$  component,

$S_{T_i}$  ... lifetime year of  $i^{th}$  component

$E_{an}$  ... energy supplied per year.

[Yang et al., 2007] describe a model for optimising the capacity of the components of a hybrid solar-wind system with the objective of minimising the probability of loss of power supply (LPSP) and the levelled costs of energy (LCE).

### 3.3.4 Maximising Profit

A further objective for an optimal sizing problem can be the systems profit. The difference between revenue and costs must be maximised

while modifying the capacity size of the renewable sources as well as of the battery storage on condition of meeting the energy demand [Verma, Kumar, 2010]. Some papers propose to maximise the profits by maximising the electricity sold to a distribution network. Sold energy at time  $t$  can be expressed as the difference between produced power and power demand [Nowdeh et al., 2012]:

$$P_{ES}(t) = P_{prod} - P_{load}$$

with:

$P_{ES}$  ... sold energy,

$P_{prod}$  ... produced energy,

$P_{load}$  ... energy demand.

[Nowdeh et al., 2012] discuss the modelling of a Mixed Integer Linear Program with the objective to maximise the sold energy. The model is solved by using GAMS software. First the proposed hybrid energy system provides the power demand. In peak times energy can be sold to a distribution network to compensate for some costs. Also [Verma, Kumar, 2010] propose a Mixed Integer Linear Program which is solved by using GAMS software but with the objective to maximise the difference between the revenue and the systems costs. Based on [Verma, Kumar, 2010] the objective function can be formulated as follows:

$$\sum_{t=1}^T (p_t * \sum_{i=1}^N (P_{sup_{i,t}}) - C_t)$$

with:

$T$  ... lifetime years,

$N$  ... number of components,

$p_t$  ... electricity price at time  $t$ ,

$P_{sup_{i,t}}$  ... supplied power by  $i^{th}$  component at time  $t$ ,

$C_t$  ... total costs of the system at time  $t$ . Total costs consist of shut-down-, start-up-, and operating costs of a component.



## Chapter 4

# Mathematical Models for Solving the Problem of Optimal Sizing

In this Chapter three different optimisation methods for minimising the costs of a hybrid energy system are introduced. Since a small system cannot meet the energy demand and an oversized system generates too high costs, it is important to size the system optimally. Models by [Ashok, 2007], [Billionnet et al., 2014] and [Tazvinga et al., 2013] will be discussed, analyzed and finally compared with each other.

The hybrid energy systems considered are mainly composed of renewable energy sources, a battery storage and a diesel generator. The energy demand should ideally be met by the renewable sources. In case of higher demand, which the renewable sources cannot generate in sufficient amount, the battery storage is discharged to meet the power demand. In case of lower demand, the power generated by the renewable sources charges the battery storage. If the demand cannot be met by either the renewable sources or by the battery storage, the diesel generator is switched on to provide the energy in demand. The diesel generator switches off when the renewable sources and/or the battery storage can

again fully satisfy the demand.

The optimisation problem is to find a strategy which schedules the functional interaction between renewable sources, battery storage and diesel generator optimally while satisfying the energy demand, taking into account the availability of renewable sources and considering limits of operation [Ashok, 2007] [Billionnet et al., 2014] [Tazvinga et al., 2013].

[Tazvinga et al., 2013] propose a method for minimising fuel costs, while [Ashok, 2007] and [Billionnet et al., 2014] consider minimising life-cycle costs, which are given by the sum of investment costs and operating costs. Since investment costs are constant, they can be removed from the operating costs which allows a comparison of all three optimisation models.

## 4.1 Non-Linear Programming

[Ashok, 2007] propose non-linear programming for minimising life-cycle costs. The aim is to minimise the annual operating costs based on daily operating costs. Since investment costs are constant they can be added at the end of the minimising process to determine the optimal solution.

### 4.1.1 Problem Formulation

The objective function for minimising operational costs is stated as follows:

$$\min C_{ot} = \sum_{i=1}^{365} \sum_{t=1}^{24} C_{oh}(t) + C_{ow}(t) + C_{os}(t) + C_{og}(t) + C_{ob}(t)$$

where:

$C_{oh}(t), C_{ow}(t), C_{os}(t), C_{og}(t), C_{ob}(t)$  are the operational costs of the single components for an hourly interval ( $t=1, \dots, 24$ ).

The following constraints (4.1)–(4.3) represent the power outputs of the renewable sources:

$$P_h = H_{net} * Q * g * \rho_{wat} * \eta_h \quad (4.1)$$

$$P_w = V_r^3 * A * C_p * \rho_a * \eta_g * \eta_t \quad (4.2)$$

$$P_s = I_{pv} * V_{pv} * N_{pvs} * N_{pvp} * \eta_{pv} \quad (4.3)$$

The constraint (4.4) corresponds to the fuel costs of the diesel generator:

$$F = a * P^2 + b * P + c \quad (4.4)$$

The constraints (4.5)–(4.6) represent the charge– and discharge dynamics of the battery storage, respectively:

$$P_b(t) = P_b(t-1) * (1 - \sigma) - \left( \frac{P_h(t)}{\eta_i} - P_l(t) \right) \quad (4.5)$$

$$P_b(t) = P_b(t-1) * (1 - \sigma) + \left( P_h(t) - \frac{P_l(t)}{\eta_i} \right) * \eta_b \quad (4.6)$$

The costs of electricity per unit,  $C_{oe}$ , are used to determine the optimal solution. They are calculated from the annual life-cycle costs divided by the electrical load supplied per year. The annual life-cycle costs are composed of investment costs and minimised operating costs.

$$C_{oe} = \frac{C_{an}}{E_l} \quad \text{with} \quad C_{an} = C_c * CRF + C_{ot},$$

where  $C_c$  describes the total investment costs composed of the investment costs of all units:

$$C_c = \sum_{h=1}^{N_h} C_h + \sum_{w=1}^{N_w} C_w + \sum_{s=1}^{N_s} C_s + \sum_{g=1}^{N_g} C_g + \sum_{b=1}^{N_b} C_b,$$

where  $N_i$  are the numbers, and  $C_i$  the investment costs of installed units (for  $i = h, w, s, g, b$ ). Finally,  $CRF$  is a capital recovery factor for the system and  $E_l$  is the supplied energy load in  $kWh$  per year.

Table 4.1: Variables and parameters [Ashok, 2007]

$C_{ot}$	sum of operational costs
$C_{oh}(t)$	operational costs of a micro–hydro turbine for an hourly interval
$C_{ow}(t)$	operational costs of a wind turbine for an hourly interval
$C_{os}(t)$	operational costs of a solar panel for an hourly interval
$C_{og}(t)$	operational costs of a diesel generator for an hourly interval
$C_{ob}(t)$	operational costs of a battery system for an hourly interval
$P_h(t)$	total power generated by micro–hydro turbine (kW)
$P_w(t)$	total power generated by wind turbine (kW)
$P_s(t)$	total power generated by solar panel (kW)
$P_b(t)$	battery power at the end of time interval $t$
$P_b(t - 1)$	battery power at the beginning of time interval $t$
$P_l(t)$	power demand
$H_{net}$	effective water head
$Q$	flow rate
$g$	acceleration due to gravity
$\rho_{wat}$	density of water
$\eta_h$	hydro efficiency
$V_r$	wind velocity
$A$	wind turbine rotor swept area
$C_p$	power coefficient of wind turbine
$\rho_a$	density of air
$\eta_g$	wind generator efficiency
$\eta_t$	wind turbine efficiency
$I_{pv}$	module operating current
$V_{pv}$	module operating voltage
$N_{pvs}$	number of series solar cells
$N_{pvp}$	number of parallel solar cells
$\eta_{pv}$	conversion efficiency of a PV–module

Table 4.2: Nomenclatur [Ashok, 2007]

$F$	fuel costs
$a, b, c$	fuel cost coefficients
$P$	total power generated by diesel generator (kW)
$\sigma$	self-discharge factor
$\eta_i$	inverter efficiency
$\eta_b$	battery charging efficiency
$C_{oe}$	unit costs of electricity
$C_{an}$	total annualized life-cycle costs
$E_l$	load served in kWh/year
$C_c$	total capital costs
$CRF$	capital recovery factor
$N_h$	number of installed micro-hydro turbines
$N_w$	number of installed wind turbines
$N_s$	number of installed solar panels
$N_g$	number of installed diesel generators
$N_b$	number of installed battery systems
$C_h$	investment costs of installed micro-hydro turbine
$C_w$	investment costs of installed wind turbine
$C_s$	investment costs of installed solar panel
$C_g$	investment costs of installed diesel generator
$C_b$	investment costs of installed battery system

### 4.1.2 Algorithmic Procedure

The algorithm used in Ashok's paper can be described as follows:

- 1) *select any combination of renewable sources out of  $2^n - 1$*
- 2) *initialize  $N_h = N_w = N_s = 1$*
- 3) *calculate  $\Delta P = P_h * N_h + P_w * N_w + P_s * N_s - load$* 
  - $\Delta P > 0$ : *return  $N_h, N_w, N_s$*
  - $\Delta P < 0$ : *increase  $N_s = N_s + 1$* 
    - *calculate generated power per hour*
    - *determine initial scheduling based on:*
      - \*  $\Delta P > 0$ : *charge battery*
      - \*  $\Delta P < 0$ : *discharge battery (if sufficiently charged)*
      - \*  $(\Delta P + \text{battery state of charge}) < 0$ : *switch on diesel generator*
    - *optimal scheduling*
    - *calculate*
      - \* *annual life-cycle costs*
      - \* *unit costs of energy*
      - \* *percentage of contribution*
    - *increment  $N_w = 2, 3, 4, \dots?$* 
      - \* *yes:  $N_s = 1$  and return to step 3)*
      - \* *no:  $i = i + 1$  and return to step 2) while  $i < 2^3 - 1$ .*  
*If  $i > 2^3 - 1$ : display calculated costs and percentage of contribution for all combinations*
- 4) *select the combination with 100% renewable energy and minimal unit costs of energy*

### 4.1.3 Properties of the Optimisation Problem

Ashok's method is an iterative algorithm, in which hydrokinetic-, wind- and solar energy are taken into account as renewable sources. At each iteration the step numbers of either wind-turbines, PV-panels or battery storage are increased as long as the power output is lower than the energy demand. Once the power output is greater than the demand, values of annual life-cycle costs, unit costs of energy and percentage of contribution are calculated to allow for a comparison of the differently combined systems.

At the beginning the numbers of the installed battery storage and diesel generator are set to one since the aim is to meet the demand only through renewable sources. Apart from that, the capital- and operating costs of the battery system and the diesel generator are very high. The number of micro-hydrokinetic turbines is set to one as the power output per unit is relatively high compared to the output of one wind turbine or one PV-panel. The considered hydrokinetic turbine is a micro-hydro turbine. The battery storage is sized based on a curve of energy data. The capacity must be equal to the difference between negative and positive peaks of the curve. The function for modelling the diesel generator is quadratic in good approximation to data of rated power. Constraints are non-linear. They are modelled in such a way that renewable sources are more likely being used than the diesel generator.

Since three renewable sources are integrated, there are  $2^3 - 1 = 7$  combinations for generating energy. The combination with the lowest total costs, a minimum usage of the diesel generator and a reliable supply of the power needed is the optimal one. Investment costs are incorporated accurately. The aim is to minimise the annual operating costs based on daily time intervals, which are again composed of hourly periods. The developed model can be solved by non-linear constrained optimisation techniques. [Ashok, 2007] uses a Quasi-Newton method for solving the optimisation problem. Results will be discussed in Chapter 5.

## 4.2 Quadratic Programming

Please note that the remaining variables and parameters used in the following problem formulation are summarized in Table 4.2.1.

[Tazvinga et al., 2013] propose Quadratic Programming for minimising operational costs. Based on the assumption that the main part of operating costs arise from using a diesel generator the aim is to minimise the fuel costs.

### 4.2.1 Problem Formulation

The objective function for minimising fuel costs is stated as follows:

$$\min C_f \sum_{t=1}^{24} (a * P_1^2(t) + b * P_1(t)),$$

where  $C_f$  is the fuel price.

The constraint (4.7) states that the energy flow from PV-panels to the supply and to the battery cannot exceed the amount of power generated by PV-panels:

$$P_2(t) + P_3(t) \leq P_s(t). \quad (4.7)$$

The constraint (4.8) indicates that the energy demand must be met by power generated by the diesel generator, battery storage and/or the PV-system:

$$P_1(t) + P_2(t) + P_4(t) = P_l(t). \quad (4.8)$$

The constraints (4.9) and (4.10) state that an energy flow cannot be negative and is bounded by a lower- and an upper bound:

$$0 \leq P_i(t) \quad , \quad i = 1, 2, 3, 4, \quad (4.9)$$

$$P_i^{min} \leq P_i(t) \leq P_i^{max}. \quad (4.10)$$

The constraint (4.11) bounds the state of charge of the battery system and states the dynamics of (dis)charging the battery storage, namely



initial state plus energy flow generated by PV-modules minus energy flow to the supply:

$$B_c^{min} \leq B_c(0) + \eta_c \sum_{\tau=1}^t P_3(\tau) - \eta_d \sum_{\tau=1}^t P_4(\tau) \leq B_c^{max}. \quad (4.11)$$

Table 4.3: Variables and parameters [Tazvinga et al., 2013]

$a, b$	fuel cost coefficients
$P_1(t)$	control variable representing energy flow from the diesel generator to the supply at any hour (kW)
$P_2(t)$	control variable representing energy flow from the PV array to the supply at any hour (kW)
$P_3(t)$	control variable representing energy flow from the PV array to battery at any hour (kW)
$P_4(t)$	control variable representing energy flow from the battery to the supply at any hour (kW)
$P_l(t)$	control variable representing the supply at any hour (kW)
$B_C(t)$	state of charge of the battery system at any hour
$B_C(t - 1)$	state of charge of the battery system at the previous hour
$B_C(0)$	initial state of charge of the battery
$B_C^{min}$	minimum allowable battery system capacity (kWh)
$B_C^{max}$	maximum allowable battery system capacity (kWh)

### 4.2.2 Properties of the Optimisation Problem

[Tazvinga et al., 2013] discuss a PV–hybrid energy system. The energy demand should mainly be met by energy from the PV–panels. In case of lacking renewable sources the battery system should be activated. The diesel generator will only be switched on if the demand cannot be met by either the PV–system or the battery storage. PV–system, battery system and diesel generator can also work as a compound structure. Energy generated by the PV–system and the diesel generator is modelled as a control variable in the range of a lower– and an upper bound. The battery system is modelled as a storage entity with a lower– and an upper bound of capacity.

[Tazvinga et al., 2013] do not take into account costs for investment. Costs for operating the PV–system or the battery storage are not incorporated due to the short time interval. The operating costs for the diesel generator are comprised of the fuel costs. Fuel costs are modelled as a non–linear function of the energy flow from the diesel generator to the supply [Seeling–Hochmuth, 1997]. Experimental tests have shown that a linear function is only relevant for supplying light loads [Ashok, 2007].

The state of charge of the battery storage at time  $t$  mainly depends on the state of charge at time  $t - 1$ . Whether the battery is charging or discharging depends on the power output of the PV–panels and on the energy demand. The diesel generator is not supposed to charge the battery storage.

The problem of optimisation is the scheduling of generating energy while minimising fuel costs as well as satisfying operational limits and the power demand. The power demand is a fixed value per hour based on empirical data. [Tazvinga et al., 2013] differentiate between summer– and winter data, as well as weekend– and weekday loads. Parameters like size, efficiency and capacity of PV–panels, battery system and diesel generator are already known. They are chosen based on a sizing model

in [Tazvinga, Hove, 2012]. This paper focuses on the development of a model for designing the hybrid energy system, which is then optimised in the paper by [Tazvinga et al., 2013] discussed above. The aim is to find an optimal strategy for generating energy for a given system. The problem is solved using Matlab using the function *quadprog*. Results will be discussed in Chapter 5.

### 4.3 Mixed Integer Linear Programming

[Billionnet et al., 2014] propose a Mixed Integer Linear Program for minimising the total costs of a hybrid energy system. The total costs are composed of the investment costs for the wind-, photovoltaic- and battery system and the operational costs for the diesel generator, which mainly depend on the amount of energy generated. The investment- and maintenance costs of the diesel generator are not part of the optimisation process, but assumed to be fixed.

#### 4.3.1 Problem Formulation

With the variables and parameters summarized in Table 4.3.1, the objective function for minimising costs is stated as follows:

$$\min \quad C^w x^w + C^p x^p + C^b x^b + C^g \sum_{t=1}^T e_t^g.$$

The constraint (4.12) ensures that the energy demand is satisfied:

$$E_t^p x^p + E_t^w x^w - e_t^{in} + \gamma e_t^{out} + e_t^g \geq D_t. \quad (4.12)$$

The following constraints (4.13)–(4.15) limit the charge, discharge and load of the battery:

$$e_t^{in} \leq x^b E^{in}, \quad (4.13)$$

$$e_t^{out} \leq x^b E^{out}, \quad (4.14)$$

$$e_t^b \leq x^b K. \quad (4.15)$$

The load of the battery system is constituted by the load at time  $t - 1$  plus generated energy, which flows in, minus the amount of energy, which flows out, to meet the demand:

$$e_t^b = e_{t-1}^b + e_t^{in} - e_t^{out}. \quad (4.16)$$

Constraints listed in (4.17) allow bounding the number of installed units:

$$x^p \leq N_{max}^p, \quad x^w \leq N_{max}^w, \quad x^b \leq N_{max}^b. \quad (4.17)$$

The number of installed units must be non-negative and an integer, the amount of generated energy is non-negative and real:

$$x^w, x^p, x^b \in \mathbb{N}, \quad e_t^{in}, e_t^{out}, e_t^b, e_t^g \in \mathbb{R}^+, \quad e_0^b = 0. \quad (4.18)$$

Table 4.4: Variables and parameters [Billionnet et al., 2014]

$C^w$	costs of a wind turbine
$C^p$	costs of a PV-panel
$C^b$	costs of a battery system
$C^g$	unit costs for 1 $kWh$ generated energy
$x^w$	number of wind turbines
$x^p$	number of PV-panels
$x^b$	number of battery units
$E_t^p$	expected nominal output power of solar panels
$E_t^w$	expected nominal output power of wind turbines
$E^{in}$	maximum charge per hour ( $kWh$ )
$E^{out}$	maximum discharge per hour ( $kWh$ )
$e_t^{in}$	amount of charged energy in the battery at time $t$
$e_t^{out}$	amount of discharged energy from the battery at time $t$
$e_t^g$	amount of energy generated by diesel generator at time $t$
$e_t^b$	load of the battery at time $t$
$D_t$	expected energy demand per time interval
$\gamma$	rate of return per 1 $kWh$ charging the battery
$K$	capacity of battery system
$N_{max}^p$	maximum number of installed solar panels
$N_{max}^w$	maximum number of installed wind turbines
$N_{max}^b$	maximum number of installed battery systems

### 4.3.2 Properties of the Optimisation Problem

[Billionnet et al., 2014] formulate a method that integrates wind- and solar energy as renewable sources, and prove that the model has an optimal solution. Further they show that the model can be extended by other renewable sources and that the generated problem is NP-hard. That is, an algorithm for solving it can be translated into one for solving

any NP–problem<sup>1</sup> [Leung, Anderson, 2004]. This is proved by showing that the bounded knapsack problem (BKP) can be reduced to the generated problem. Since the optimisation problem of BKP is NP–hard, the generalised optimisation problem for more than two renewable sources is NP–hard. The proof can be seen in [Billionnet et al., 2014].

Further, the paper deals with a problem that allows for a varying demand, the robust problem. The robust problem is partitioned into a two–stage problem, whereof the second stage is the interesting one for this master thesis. It deals with the minimisation of energy generated by the diesel generator and is solved using either a standard solver or a dynamic programming approach. Both methods are compared with each other regarding CPU time and minimised costs. We will look at the results in Section 5.2. The robust problem is then solved using a constraint generation algorithm.

The paper by [Billionnet et al., 2014] assumes that generating energy by renewable sources has no operational costs. Therefore only investment costs need to be taken into account. Operating costs only accrue from using the diesel generator, which are the costs for fuel. They are denoted as unit costs per 1 kWh. Since investment– and maintenance costs for a diesel generator are fixed, they are not part of the optimisation process.

The problem focuses on a time span of one year which is composed of  $T$  time periods of one hour. One time period lasts from  $t - 1$  to  $t$ . One advantage of hourly time intervals is that changing weather conditions can be taken into account. This is an important factor as the output of renewable sources mainly depends on weather conditions. As a function of weather conditions and location the type and characteristics of the wind turbines and PV–panels need to be predetermined. An essential characteristic is the nominal output power per time interval. The number of wind turbines and PV–panels will be calculated as an outcome of the op-

<sup>1</sup> NP=nondeterministic polynomial time

timisation process. The denoted costs include investment-, installation- and annual maintenance costs per unit. The battery storage is composed of connected units where the number of units has to be determined during the optimisation process. Each unit has a minimal load and a maximal capacity, as well as a maximal charge and discharge per hour. These properties are predetermined by the manufacturer. Using the battery storage induces a loss of energy which means that only a certain percentage of 1 kWh charged energy is available. Further, it is assumed that either all battery units are charging or all units are discharging. Under that constraint the operation of the battery system is optimal. Depending on characteristics of the location, wind turbines and PV-panels and evaluated data regarding demand, a maximum number of wind turbines, PV-panels and battery units has to be predetermined.

The original problem (4.3.1) can be solved using any MILP-software since it has only three integer variables. The following section deals with an extension of the problem, the robust problem. The above problem is discussed with regard to the modification of taking varying demand into account, as a varying demand on energy is more realistic.

### 4.3.3 Extension of the Problem

So far we have discussed the above optimisation problem with a fixed value for demand. As realistically demand depends on season, daytime and weather conditions, it is useful to allow for a varying demand in a certain domain  $\mathfrak{D}$ . The objective is to find a feasible solution  $(x, e)$ , consisting of the number of installed units  $x$  and the amount of supplied energy  $e$ , that minimises the total costs of the system.

Following [Billionnet et al., 2014], the domain can be stated as follows:

$$\mathfrak{D} = \{d \in \mathbb{R}_+^T : d_t = D_t + \delta_t \Delta_t, \sum_{t=1}^T \delta_t \leq \bar{\delta}, 0 \leq \delta_t \leq 1, t = 1, \dots, T\}.$$

Demand  $d_t$  is between  $D_t$  and  $D_t + \delta_t \Delta_t$  depending on the uncertainty of demand.  $D_t, \Delta_t$  and  $\bar{\delta}$  are data, depending on site, weather conditions

and historically evaluated data regarding demand.  $\delta_t$  represents the uncertainty of demand at time  $t$ . As we only discuss worst case scenarios,  $\delta_t$  is between 0 and 1. (If the aim was to view a varying demand in worst- and best case scenarios, we would consider  $-1 \leq \delta_t \leq 1$ .) The cumulated value of  $\delta_t$  is bounded above by  $\bar{\delta}$ , which is an integer.  $\bar{\delta}$  must be chosen between 0 and  $T$ . For all  $t$ :

- $\bar{\delta} = T \quad \Rightarrow d_t = D_t + \delta_t \Delta_t$
- $\bar{\delta} = 0 \quad \Rightarrow d_t = D_t$

$\bar{\delta}$  plays an important role in the optimisation process, because only from a certain level of  $\bar{\delta}$  the demand is met at any time. Also CPU time depends on the choice of  $\bar{\delta}$ . Some results regarding CPU times are discussed in Chapter 5.

As in [Billionnet et al., 2014] we first quote the extended problem:

$$EP : \quad \min_{x \in \mathcal{P}^x} C^p x^p + C^w x^w + C^b x^b + \max_{d \in \mathcal{D}} \min_{e \in \mathcal{P}^e} C^g \sum_{t=1}^T e_t^g \quad (4.19)$$

subject to

$$E_t^p x^p + E_t^w x^w - e_t^{in} + \gamma e_t^{out} + e_t^g \geq d_t.$$

$\mathcal{P}^x$ ,  $\mathcal{P}^e$  denote the polyhedrons defined by the constraints on  $x$  and  $e$ , i.e., the constraints (4.12) – (4.18). For feasible  $x$  we can derive the recourse problem [Billionnet et al., 2014]:

$$\max_{d \in \mathcal{D}} \min_{e \in \mathcal{P}^e} C^g \sum_{t=1}^T e_t^g$$

subject to

$$E_t^p x^p + E_t^w x^w - e_t^{in} + \gamma e_t^{out} + e_t^g \geq d_t.$$



### Solving the Recourse Problem

Following [Billionnet et al., 2014], we will give a brief outline of how to solve the recourse problem. From [Thiele et al., 2014] we know that there is an optimal solution for the recourse problem.

The worst case scenario is  $\sum_{t=1}^T \delta_t = \bar{\delta}$ . Thus  $\delta_t = 1$  for  $\bar{\delta}$  periods,  $\delta_t = 0$  for the other periods. The aim of solving the problem is to find the  $\bar{\delta}$  periods, i.e., when the power demand is high. [Billionnet et al., 2014] propose a dynamic programming model as it is supposed to solve the problem in polynomial time.

Since the amount of installed units  $x$  is assumed to be fixed,  $E_t^p x^p + E_t^w x^w$  is fixed. We can achieve a fixed demand, which still needs to be met:  $\hat{D}_t = D_t - E_t^p x^p - E_t^w x^w$ , as well as a varying demand:  $\hat{d}_t = d_t - E_t^p x^p - E_t^w x^w = \hat{D}_t + \delta_t \Delta_t$

It is assumed that the number of installed battery-units is equal to 1:  $x^b = 1$ . Further, the battery load at time  $t$ ,  $e_t^b$ , as well as the amount of energy supplied by the diesel generator at time  $t$ ,  $e_t^g$ , can be determined from  $e_{t-1}^b$  depending on the amount of demanded energy  $\hat{d}_t$  in excess or lack:

- $\hat{d}_t \geq 0$ :

$$e_t^b = \max \left( 0, e_{t-1}^b - E^{out}, e_{t-1}^b - \frac{\hat{d}_t}{\gamma} \right),$$

$$e_t^g = \hat{d}_t - \gamma \min \left( e_{t-1}^b, E^{out}, \frac{\hat{d}_t}{\gamma} \right),$$

- $\hat{d}_t < 0$ :

$$e_t^b = \min \left( K, e_{t-1}^b + E^{in}, e_{t-1}^b - \hat{d}_t \right),$$

$$e_t^g = 0,$$

for given values of  $\hat{d}_t, e_{t-1}^b$  with  $0 \leq e_{t-1}^b \leq K$  and for  $t = 1, \dots, T$ .

The algorithm operates from  $\tau = T$  to  $\tau = 1$  and looks for an optimal operating strategy for each period depending on the battery load at the beginning of each period as well as on the number of time periods with  $\delta_t = 1$  among the  $(T - \tau + 1)$  time periods. For a discussion of the program in detail please refer to [Billionnet et al., 2014]. Results will be discussed in Chapter 5.

# Chapter 5

## Comparative Analysis

The following chapter discusses results of the optimisation procedures and analyzes the methods comparatively. Characteristics of the sites, the process of selecting the system components and resulting costs as well as the share the energy systems have in supplying the needs are considered.

### 5.1 Characteristics of Considered Cites

Stand-alone hybrid energy systems, which are used for meeting the energy demand of a village, are most common in rural areas with a low population density and scattered settlements. If the location is miles away from a grid line it is more cost effective to build a decentralised system which is not connected to the grid. In this case diesel generators are often given preference because of the low investment costs. Ultimately, there are high operational costs due to a high consumption of fuel as well as costs for maintenance. Incorporating a battery storage system and renewable resources for the supply of energy can greatly reduce the life-cycle costs [Tazvinga, Hove, 2012].

The three optimisation models discussed above can be applied to the optimisation process for rural areas all around the world.

[Tazvinga et al., 2013] talk about a rural area in Zimbabwe, South Africa, which is remote from an existing grid line. Due to the high amount of solar radiation, a photovoltaic–battery–diesel power system is considered.

[Ashok, 2007] discusses the optimal sizing of a hybrid energy system located in Kerala, India. He presents a farming village of Western Ghats which is 110 *km* apart from the nearest local town. As the existing grid is 15 *km* away, an extension of the grid would be too expensive. The village houses 120 families or 600 people. So far, there is a diesel generator to cover the energy demand. It operates six hours per day and supplies energy to 35% of the population. Some houses use a small generator which can provide 1 *kVA*, but 40% of the population do not have any access to electricity. Potential renewable resources comprise several water streams, wind energy and solar energy.<sup>1</sup>

[Billionnet et al., 2014] discuss a rural area in Montana, USA. Montana has a very low population density with around two inhabitants per *km*<sup>2</sup> [U.S. Census, 2012].

Generally it can be said that hybrid energy systems are mainly built in areas with a low population density, that are remote from an existing grid. In the long term, a hybrid energy system can be more cost–effective than a grid extension, depending on the distance to an existing grid and on the energy demand. The higher the energy demand, the higher the investment costs for a hybrid system. The further away the existing grid, the higher the extension costs. An optimal trade–off must be found by comparing the costs for an optimal hybrid energy system and the costs for a grid extension. Another important issue in building a hybrid energy system is the capability of renewable energy sources. The best parameter for the evaluation of the solar energy potential is the global horizontal irradiation (see Figure 5.1). This is the sum of direct normal irradiance, diffuse horizontal irradiance, and ground reflected irradiation.

---

<sup>1</sup> Data from People’s School of Energy, Kannur, Kerala.

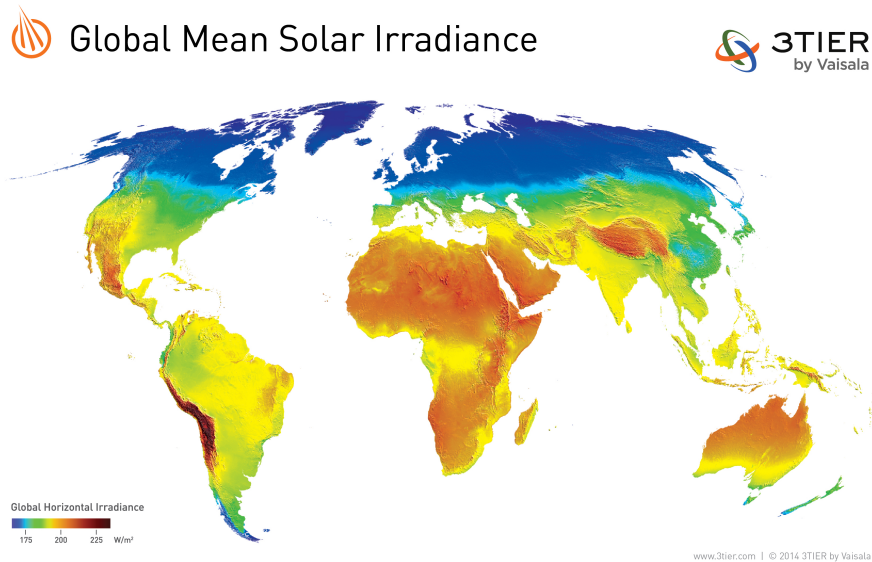

Figure 5.1: Global horizontal irradiation [3tier, 2014]

Related to the papers discussed above it can be seen that Zimbabwe has a solar energy potential of around  $6,5 \text{ kWh/m}^2$ , Kerala of around  $7 \text{ kWh/m}^2$  and Montana of around  $4,5\text{--}5 \text{ kWh/m}^2$ .

Figure 5.2 shows wind speed worldwide. Relating to the above papers it can be seen that wind speed in Montana amounts to  $6\text{--}9 \text{ m/s}$  and  $5\text{--}9 \text{ m/s}$  in Kerala.

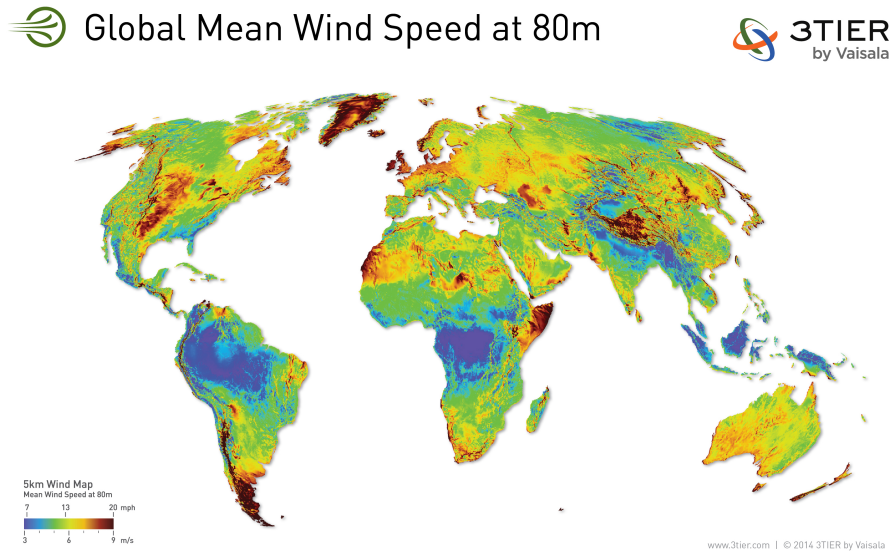

Figure 5.2: Global wind speed [3tier, 2014]

## 5.2 Results

### 5.2.1 Results of the Iterative Method

[Ashok, 2007] proposes an iterative optimisation method. It tests seven combinations of a hybrid energy system composed of three renewable energy sources. The number of hydrokinetic-turbines is set to one as the power output is high in comparison with the output of a wind-turbine or a PV-panel. The numbers of wind-turbines and PV-panels also start from one but will be increased following the algorithmic procedure.

An interesting result is that the optimal combination does not incorporate PV-panels. Due to high capital costs for PV-panels only micro-hydro- and wind-turbines are suggested as renewable sources. During peak time in the evenings, the battery storage helps to meet the demand.

Another interesting result is that the hybrid energy system goes without a diesel generator. Due to high maintenance- and operating costs, like fuel, no diesel generator is incorporated. The main part of the demand is met by the hydrokinetic turbine. It supplies 78% of the energy. Two wind turbines supply 22% and the battery throughput is 85 *kWh* per day. The unit costs for the optimal system are Rs. 6,5/*kWh*, which corresponds to 0,0816*EUR/kWh*. The optimal system can fully meet the power demand through the employment of renewable sources only.

In Table 5.1 the costs for the estimated daily average demand of 317 *kWh* are given for three different systems: an optimal hybrid energy system, a grid extension and a diesel generator. The costs for a grid extension are calculated on the basis of an annualised grid extension charge of Rs. 50.000/*km*, that is around 633,5/*km*, and grid energy costs of Rs. 4/*kWh*, that is around 0,05 *EUR/kWh*.

Table 5.1: Cost comparison [Ashok, 2007]

system	daily operation hours	population electrified	EUR/kWh
HES	24	100%	25,87
grid	24	100%	28,21
DG	6	40%	41,21

The hybrid energy system is more cost-effective than a grid extension by 8,3% and 37,2% more cost-effective than using a diesel generator.

### 5.2.2 Results of Quadratic-Programming

[Tazvinga et al., 2013] propose a quadratic program for minimising the costs of an existing hybrid energy system. They refer to a previous paper written by [Tazvinga, Hove, 2012], which is about the optimal component sizing of the considered system. The optimal component sizing is developed from a spreadsheet-based mathematical model with the objective

of minimising the unit energy costs (see Section 4.2).

In the paper by [Tazvinga et al., 2013], the discussed system makes use of solar energy as single renewable source. The constraints ensure that PV-energy is prioritised for covering the energy demand and charging the battery storage. Only when the PV-output is lower than the power demand, the diesel generator is switched on. Due to the fact that the battery is only charged by the PV-system (not by the diesel generator) it is ensured that the PV-system is used as much as possible, and no energy is wasted.

The results show that the battery storage is charged during the day and supplies energy during the night. During night hours until early morning, the demand has to be met either by the diesel generator or the battery system if the *SOC* is within the limits. In the morning and towards sunset all three components function jointly. During the day, the diesel generator switches off as soon as the PV- and the battery-system can fully supply the power in demand. Working hours of the diesel generator depend on the PV-power output and the battery *SOC*. Generally it can be said that the PV-output is higher in summer than in winter. At the same time, the energy demand is lower in summer than in winter. Those facts result in fewer working hours of the diesel generator in summer. [Tazvinga et al., 2013] also differentiate between weekends and weekdays. Due to work and other activities, the demand on weekdays is generally lower than on weekends, both in summer and in winter. Table 5.2 shows the fuel costs for meeting the energy demand by using the hybrid energy system compared with the sole use of the diesel generator.

It can be seen that the hybrid energy system is more cost-effective than the diesel generator – by 74,8% in winter and by 81,4% in summer. The significant difference in fuel costs between summer and winter shows that it is very important to consider seasonal variations in demand. Considering a varying demand ensures a more accurate minimisation of costs.



Table 5.2: Cost comparison in EUR [Tazvinga et al., 2013]

energy system	winter weekend	winter weekday	summer weekend	summer weekday
HES	10,02	8,57	6,37	5,16
DG	39,00	35,29	33,16	28,68

### 5.2.3 Results of Mixed–Integer–Programming

[Billionnet et al., 2014] propose a Mixed Integer Program, solved by using a standard solver as well as a dynamic programming model. The original problem is reformulated into a two–stage problem with varying demand. The dynamic programming method is deduced for the second stage problem, which is about minimising the power generated by the diesel generator. This approach is then compared to using a standard solver regarding CPU time and minimised costs. Looking at the results in Table 5.3 it can be seen that the factor  $\bar{\delta}$  plays an important role, where  $\bar{\delta}$  is the upper bound of the cumulated value of the uncertainty at time  $t$ :  $\sum_{t=1}^T \delta_t \leq \bar{\delta}$  (see Section 4.3.3).

Table 5.3: Costs (EUR) per system for T=8760 [Billionnet et al., 2014]

$\bar{\delta}$	0	100	500	700	850	1000	8760
$x^w$	45	46	48	48	48	48	48
$x^p$	64	65	67	67	67	67	67
$x^b$	467	476	499	499	499	499	499
costs	37818,1	39099,2	41356	41630,2	41630,2	41630,2	41630,2

The optimal value increases with  $\bar{\delta}$  until a certain threshold is reached, which here is 700. From 700 onwards it remains constant. Since any solution of  $\bar{\delta} = \hat{\delta}$  is feasible for  $\bar{\delta} > \hat{\delta}$ , the optimal value can not decrease when  $\bar{\delta}$  increases. Once  $\bar{\delta}$  is large enough, the costs remain constant.

That means that once the optimal system can cover the demand during some critical periods, it can cover the demand at any time.

Table 5.4 shows a comparison of the CPU times of the dynamic programming method and the standard solver, here Cplex.

Table 5.4: CPU time in sec. [Billionnet et al., 2014]

$\bar{\delta}$	0	100	500	700	850	1000	8760
dynamic programming	82	90	97	95	94	102	67
standard solver	46	88	7422	375	204	65	22

It can be seen that the dynamic programming method is fast throughout. The CPU time of the standard solver increases rapidly for  $100 < \bar{\delta} < 850$ . For  $\bar{\delta} > 850$  the CPU time decreases again because less and less nodes are explored in the underlying branch & bound algorithm [Billionnet et al., 2014].

As already mentioned in the legend of Table 4.3.1, a timespan of one year is chosen ( $T=8760$ ). The uncertainty regarding demand is calculated based on a variation of 10% from the mean value. The number of installed units is bounded above by 500.

[Billionnet et al., 2014] propose a very accurate method for solving the optimal sizing problem. The exact incorporation of a varying demand allows for a precise calculation of estimated costs.

# Chapter 6

## Summary

The following sections propose some key features and parameters when considering optimisation problems for designing a hybrid energy system. The suggested features and parameters result from the comparison of the above discussed optimisation techniques.

### 6.1 Choice of Renewable Sources

This section will deduce parameters that should be taken into account while assessing the renewable sources to be used in a hybrid energy system.

When considering photovoltaic systems the landscape or structure conditions play an important role. Those must be examined in detail. Clearly PV-systems in built-up areas have different requirements than systems in agricultural areas. Some aspects to bear in mind with regard to built-up areas are: the location of a PV-system must be on the top of a building, south-facing or horizontal, and it must allow for a slope of less than  $35^\circ$  [Boxleitner et al., 2011]. Aspects to consider regarding agricultural systems are: module efficiency, related output efficiency and insulation per year [Boxleitner et al., 2011]. For that purpose, the horizontal global irradiation is an essential parameter.

Generally it can be said that the higher the irradiation, the higher is the power output. However, most panels have a decreasing power output when the temperature rises above 25°C. The temperature coefficient states by how many percentage points the power output will decrease per degree when the temperature rises above 25°C [Jordan, Kurtz, 2012].

Also the lifespan of a PV-system can be affected by too extreme conditions. Panels in desert climates exhibit a decrease in power production close to 1% per year. The main reason for that is the high levels of UV exposure [Jordan, Kurtz, 2012]. Usually, a PV-module comes with a 20-year warranty, which means that the solar panels are expected to generate at least 80% of the rated power after 20 years of use. The National Renewable Energy Laboratory (NREL) conducted a meta-analysis of studies that outlined results concerning the long term degradation rates of various PV-panels. The degradation rate of PV-panels that consist of monocrystalline silicon, which is the most commonly used silicon, is less than 0,5% for panels produced before 2000 and less than 0,4% for PV-panels produced after 2000 [Jordan, Kurtz, 2012].

An essential parameter when assessing wind generators is the expected lifespan. Wind turbines have an estimated lifetime of 20 years. Most of them are designed to work for 120.000 hours within those 20 years, which is around 68% of the estimated lifespan. The average lifetime can be affected by humidity, air density or wind factors. Clearly the more turbulent the conditions are, the more the expected lifespan will decrease [WMI, 2014]. In fact, there are not many wind turbines which have reached the estimated lifetime of 20 years [Iuga, 2014]. Also, costs for operation and maintenance are hard to predict. But based on experiences with older turbines, those costs are estimated to be around 0,012–0,015 Euro per kWh of generated power, calculated over the total lifespan. Costs for operation and maintenance include costs for insurance, regular maintenance, repair, replacing parts and administration [Iuga, 2014].

Parameters for hydro turbines relate primarily to the flow rate and the head. The flow rate indicates how much water flows per second. The head represents the vertical distance the water is falling. It is recommended to consider data of at least one year to decide whether a hydro-turbine is a reasonable investment [MnstrOnt., 2014]. Data of life expectancy and costs vary greatly depending on the size of the turbine [Irena, 2012]. Micro-hydro turbines have an expected lifetime of 25–30 years [MnstrOnt., 2014].

## 6.2 Choice of Optimisation Technique

Generally it can be said that the choice of a suitable optimisation technique mainly depends on the characteristics of the optimisation problem. Nevertheless the optimisation technique can have a significant influence on the accuracy and speed of the solving process. This section will discuss some general characteristics of the optimisation methods discussed above.

[Ashok, 2007] used an iterative method to design an optimal hybrid energy system. An algorithm was implemented with the objective to compare differently combined hybrid energy systems and to calculate the total related costs. The algorithm terminated after having tested seven combinations. The number of seven results from the number of integrated energy sources and the related number of possibilities ( $2^n - 1 = 2^3 - 1 = 7$ ). Due to setting a termination criterion, the algorithm converged. Such a termination criterion is called an “A-Priori Termination Criterion”, in contrast to an “A-Posteriori Termination Criterion”, which use already computed iteration steps to determine when to stop [Colton et al., 2000]. Regarding the small size of the developed optimisation problem, an iterative method is a suitable optimisation technique for comparing all results. All the system combinations can be compared rather easily regarding their costs and their share in renewable energy.

The paper by [Tazvinga et al., 2013] uses the Matlab function *quadprog* to solve the optimisation problem. A Quadratic Programming model is developed for minimising the fuel costs. *quadprog* is an implemented function that uses an active set method for a general quadratic program [Mathworks, 2014]. Active set methods are based on the Simplex algorithm, an algorithm for solving Linear Programming models. Active set methods are efficient. The number of iterations, as a polynomial function, depends on the dimension of the problem. Some problems can even be solved in exponential time. In fact, active set methods can fail if the matrices become singular, or have difficulties in case of ill-conditioned KKT-optimality conditions [Maes, 2010]. In the case of a convex quadratic program, *quadprog* runs an interior point method. In theory those methods have a polynomial iteration bound. In practice the number of iterations does not depend on the dimensions of the matrices [Maes, 2010].

Beside that, quadratic programs can also be solved with the solver CPLEX, which is used by [Billionnet et al., 2014] to prove one of the main advantages of Dynamic Programming: the speed of solving. [Billionnet et al., 2014] use the solver for solving a Mixed Integer Linear Program. Originally, CPLEX was developed based on the simplex algorithm, implemented in the programming language *C*, although today the solver uses simplex optimisers, barrier optimisers and mixed integer optimisers based on different optimisation methods [Lima, 2010]. For solving Mixed Integer Programs, CPLEX uses a branch & cut algorithm, which is based on a branch & bound algorithm. This implementation improved the performance of CPLEX [Lima, 2010]. But for many optimisation problems, Dynamic Programming is a faster approach, as [Billionnet et al., 2014] have proved.

Dynamic Programming is a suitable method for solving complex problems. In contrast to Linear or Quadratic Programming, there is no mathematical standard formulation of the problem. It is a general ap-

proach, wherefore particular equations must be developed. Hence some mathematical knowledge and familiarity is necessary to be able to apply Dynamic Programming procedures. Still, requirements are that the problem has an optimal substructure, which means that the optimal solution is composed of optimal subsolutions. Also, the problem can be decomposed in overlapping subproblems [Bradley et al., 1977]. Even if a careful analysis is needed, Dynamic Programming can be very powerful when it comes to speed and accuracy of optimisation methods.

### 6.3 Choice of Constraints

A well-considered choice of constraints is recommended to achieve practicable results. This subsection will present some constraints as a suggestion for designing or evaluating optimisation models for hybrid energy systems.

- *Setting the systems power output to be greater than or equal to the power demand.* This is an essential constraint to ensure that the demand can be reliably met. Nevertheless, it requires that the energy consumption data of the considered site are known. In addition, the technical data of the single components must be taken into account.
- *Bounding the energy flows.* Energy flowing from renewable sources cannot be negative, as the only reasonable energy flow is from any renewable source to the demand or to the battery system. The energy flows can also be bounded above to ensure a proper functioning. This requires that the technical data of the single components are known.
- *Determining the charging process of the battery system.* It is advisable to determine the (dis)charging process of the battery storage depending on the state-of-charge of the previous stage and on the energy that flows in or out of the storage.

- *Choice of numbers set.* It is advisable to set the number of units to natural numbers and the amount of energy to real numbers.
- *Bounding the number of installed units.* If there is an upper limit of finances or space, it is recommendable to bound from above the number of installed units.
- *Considering installation- and maintenance costs.* Depending on installation costs and power output, some renewable energy sources are not integrated, if the power output is relatively low compared to the installation- and maintenance costs.

## 6.4 Conclusion

The objective of this master thesis was the development of a comparison of three different optimisation techniques for designing an optimal stand-alone hybrid energy system. The discussed models are applicable to power generation via renewable energies in rural villages. The comparison was applied to the method of optimisation, various objective functions and constraints, properties and results of each optimisation model. In fact, a one-to-one comparison is hardly feasible, as the conditions concerning site, energy demand and climate differ. Even so, there are some similarities regarding climate and remoteness. A precise comparison is hardly possible due the disparity in demand and renewable sources. Nevertheless, some results are obtained, which can help when considering the designing problem of a hybrid energy system.



# List of Figures

2.1	Potential of hydropower in Austria [Boxleitner et al., 2011]	13
2.2	Potential of wind power in Austria [Boxleitner et al., 2011]	14
2.3	Installed wind generators in Austria [IGWindkraft, 2014]	14
2.4	Potential of solar power in Austria [Boxleitner et al., 2011]	15
3.1	Hybrid Energy System with battery storage . . . . .	18
3.2	Hybrid Energy System with battery storage and H2 tank	20
3.3	Wind speed to power output [Deshmukh, Deshmukh, 2008]	24
5.1	Global horizontal irradiation [3tier, 2014] . . . . .	52
5.2	Global wind speed [3tier, 2014] . . . . .	53

# List of Tables

2.1	Limiting values for PV-systems [Boxleitner et al., 2011] .	15
4.1	Variables and parameters [Ashok, 2007] . . . . .	35
4.2	Nomenclatur [Ashok, 2007] . . . . .	36
4.3	Variables and parameters [Tazvinga et al., 2013] . . . . .	40
4.4	Variables and parameters [Billionnet et al., 2014] . . . . .	44
5.1	Cost comparison [Ashok, 2007] . . . . .	54
5.2	Cost comparison in EUR [Tazvinga et al., 2013] . . . . .	56
5.3	Costs (EUR) per system for T=8760 [Billionnet et al., 2014]	56
5.4	CPU time in sec. [Billionnet et al., 2014] . . . . .	57

# Bibliography

- [Ashok, 2007] S. Ashok. *Optimised model for community-based hybrid energy system*. *Renewable Energy*, 32, 1155–1164, 2007.
- [Bernal–Agustín, Dufo–López, 2009] J.L. Bernal–Agustín, R. Dufo–López. *Simulation and optimization of stand-alone hybrid renewable energy systems*. *Renewable and Sustainable Energy Reviews* 13, 2111–2118, 2009.
- [Billionnet et al., 2014] A. Billionnet, M.–C. Costa, P.–L. Poiron. *Robust optimal sizing of an hybrid energy stand-alone system*. [http://www.optimization-online.org/DB\\_FILE/2014/03/4291.pdf](http://www.optimization-online.org/DB_FILE/2014/03/4291.pdf), 2014, retrieved on 5.5.2014.
- [Bointner, 2013] R. Bointner. *Blue Globe Report. Erneuerbare Energien 1/2013*. [klimafonds.gv.at/assets/Uploads/Blue-Globe-Reports/BlueGlobeReportWirtschaftsfaktorErneuerbareEnergie.pdf](http://klimafonds.gv.at/assets/Uploads/Blue-Globe-Reports/BlueGlobeReportWirtschaftsfaktorErneuerbareEnergie.pdf), retrieved on 8.9.2014.
- [Boxleitner et al., 2011] M. Boxleitner, C. Groß, M. Chochole, G. Brauner, J. Hiebl, C. Springer, G. Blöschl, C. Maier, H. Schmöller. *Super-4-Micro-Grid. Nachhaltige Energieversorgung im Klimawandel*. Klima- und Energiefonds, Österreichische Forschungsförderungsgesellschaft mbH (FFG), 2011.
- [Bradley et al., 1977] S.P. Bradley, A.C. Hax, T.L. Magnanti. *Applied Mathematical Programming*. Addison–Wesley Pub. Co., Minnesota, 1977.

- [Cai et al., 2009] Y.P. Cai, G.H. Huang, Z.F. Yang, Q.G. Lin, Q. Tan. *Community-scale renewable energy systems planning under uncertainty – an interval chance-constrained programming approach*. Renewable and Sustainable Energy Reviews, 13(4), 721–735, 2009.
- [Chedid et al., 1998] R. Chedid, H. Akiki, S. Rahman. *A decision support technique for the design of hybrid solar-wind power systems*. IEEE Trans Energy Convers, 13(1), 76–83, 1998.
- [Chedid, Saliba, 1998] R. Chedid, Y. Saliba. *Optimization and control of autonomous renewable energy systems*. International Journal of Energy Research, 20(7), 609–624, 1998.
- [Colton et al., 2000] D. Colton, H. W. Engl, A. K. Louis, J. R. McLaughlin, W. Rundell. *Surveys on Solution Methods for Inverse Problems*. Springer-Verlag, Wien, New York, 2000.
- [De, Musgrove, 2007] A.R. De, L. Musgrove. *The optimization of hybrid energy conversion systems using the dynamic programming model-Rhapsody*. International Journal of Energy Research, 12(3), 447–457, 2007.
- [Deshmukh, Deshmukh, 2008] M.K. Deshmukh, S.S. Deshmukh. *Modeling of hybrid renewable energy systems*. Renewable and Sustainable Energy Reviews, 12, 235–249, 2008.
- [Dufo-López et al., 2007] R. Dufo-López, J.L. Bernal-Augustin, J. Contrerasb. *Optimization of control strategies for stand-alone renewable energy systems with hydrogen storage*. Renewable Energy, 32, 1102–1126, 2007.
- [EC, 2014] *EU Climate and Energy Policy*. [ec.europa.eu/research/energy/eu/index\\_en.cfm?pg=policy-energy-and-climate-policy](http://ec.europa.eu/research/energy/eu/index_en.cfm?pg=policy-energy-and-climate-policy), retrieved on 4.9.2014.
- [EControl, 2013] *Stromkennzeichnungsbericht 2013*. [www.e-control.at/portal/page/portal/medienbibliothek/oeko-](http://www.e-control.at/portal/page/portal/medienbibliothek/oeko-)

energie/dokumente/pdfs/Stromkennzeichnungsbericht2013.pdf,  
retrieved on 8.9.2014.

[Energiewende, 2014] *Photovoltaics*. energytransition.de/2012/09/  
f-solar/, retrieved on 4.9.2014.

[Energy 101, 2014] *How do wind turbines work?*  
<http://energy.gov/eere/wind/how-do-wind-turbines-work>,  
retrieved on 11.6.2014.

[Eurostat, 2014] *Energy dependence*. epp.eurostat.ec.europa.eu/tgm/  
table.do?tab=table& plugin=0& language=en& pcode=tsdcc310,  
2014, retrieved on 4.9.2014.

[Gupta et al., 2011] A. Gupta, R.P. Saini, M.P. Sharma. *Modelling of  
hybrid energy system*. Renewable Energy, 36, 459-481, 2011.

[Habib et al., 1999] M.A. Habib, S.A.M. Said, M.A. El-Hadidy, I. Al-  
Zaharna. *Optimization procedure of a hybrid photovoltaic wind en-  
ergy system*. Energy, 24, 919-929, 1999.

[Hefnawi, 1998] S.H. El-Hefnawi. *Photovoltaic diesel-generator hybrid  
power system sizing*. Renewable Energy, 13(1), 33-40, 1998.

[IGWindkraft, 2014] *Windkraft in Österreich, Europa und weltweit*. ig-  
windkraft.at/?xmlval\_ID\_KEY[0]=1047, retrieved on 10.9.2014.

[Irena, 2012] *Hydropower*. Renewable Energy Technologies: Cost Analy-  
sis Series, IRENA, Vol.1: Power Sector, 3(5), 2012.

[Iuga, 2014] *Operation and Maintenance Costs of Wind Generated  
Power*. [wind-energy-the-facts.org/operation-and-maintenance-  
costs-of-wind-generated-power.html](http://wind-energy-the-facts.org/operation-and-maintenance-costs-of-wind-generated-power.html), retrieved on 12.9.2014.

[Jordan, Kurtz, 2012] D.C. Jordan, S.R. Kurtz. *Photovoltaic Degrada-  
tion Rates—An Analytical Review*. Progress in Photovoltaics: Re-  
search and Applications, 2012.

- [Kaabeche et al., 2010] A. Kaabeche, M. Belhamel, R. Ibtiouen. *Optimal sizing method for stand-alone hybrid PV/wind power generation system*. Revue des Energies Renouvelables SMEE'10 Bou Ismail Tipaza, 205–213, 2010.
- [Koutroulis et al., 2006] E.Koutroulis, D. Kolokotsa, A. Potirakis, K. Kalaitzakis. *Methodology for optimal sizing of stand-alone photovoltaic/wind-generator systems using genetic algorithms*. Solar Energy, 80, 1072–1088, 2006.
- [Kroh, 2014] K. Kroh. *Bye-bye brown coal: Germany's new renewables mark*. [businessspectator.com.au/article/2014/7/10/renewable-energy/bye-bye-brown-coal-germanys-new-renewables-mark](http://businessspectator.com.au/article/2014/7/10/renewable-energy/bye-bye-brown-coal-germanys-new-renewables-mark), retrieved on 10.9.2014.
- [Kusakana, Vermaak, 2014] K. Kusakana, H.J. Vermaak. *Hybrid diesel generator/renewable energy system performance modeling*. Renewable Energy, 67, 97–102, 2014.
- [Leung, Anderson, 2004] J. Y-T. Leung, J. H. Anderson. *Handbook of Scheduling: Algorithms, Models, and Performance Analysis*. Chapman and Hall/CRC, 1st edition, Danvers, USA, 2004.
- [Lima, 2010] R. Lima. *IBM ILOG CPLEX. What is inside of the box?* [egon.cheme.cmu.edu/ewocp/docs/rlima\\_cplex\\_ewo\\_dec2010.pdf](http://egon.cheme.cmu.edu/ewocp/docs/rlima_cplex_ewo_dec2010.pdf), retrieved on 12.9.2014.
- [Maes, 2010] C.M. Maes. *A regularized active-set method for sparse convex quadratic programming*. Ph.D. Thesis at the Institute for Computational and Mathematical Engineering at Stanford University, 2010.
- [Mathworks, 2014] *quadprog*. <http://www.mathworks.de/products/matlab/>, retrieved on 6.10.2014.

- [Mehrpooya, Daviran, 2013] M. Mehrpooya, S. Daviran. *Dynamic Modeling of a Hybrid Photovoltaic System with Hydrogen/Air PEM Fuel Cell*. Iranica Journal of Energy & Environment, 4(2), 104–109, 2013.
- [MnstrOnt., 2014] *Micro Hydro Systems*. [omafra.gov.on.ca/english/engineer/ge\\_bib/micro.htm](http://omafra.gov.on.ca/english/engineer/ge_bib/micro.htm), retrieved on 12.9.2014.
- [Mostofi, Shayeghi, 2012] F. Mostofi, H. Shayeghi. *Feasibility and Optimal Reliable Design of Renewable Hybrid Energy System for Rural Electrification in Iran*. International Journal of Renewable Energy Research, 2(4), 2012.
- [Nasa, 2014] *Global climate change*. [climate.nasa.gov/causes/](http://climate.nasa.gov/causes/), retrieved on 3.9.2014.
- [Notton et al., 1996] G. Notton, M. Muselli, A. Louche. *Autonomous hybrid photovoltaic power plant using a back-up generator: a case study in a Mediterranean Island*. Renewable Energy, 7(4), 371–391, 1996.
- [Nowdeh et al., 2012] S. A. Nowdeh, A. Rajabi-Ghahnavieh, A. Bazazi. *Designing a PV/FC Hybrid System considering Sale Electricity*. Buletinul Institutului Politehnic din Iasi, Tome LVIII (LXII), Fasc. 2, 2012.
- [Pearce, 2002] J. Pearce. *Photovoltaics – A Path to Sustainable Futures*. Futures, 34(7), 663–674, 2002.
- [Pembina Institute, 2014] *Energy Source: Hydropower*. [pembina.org/re/sources/hydro-power](http://pembina.org/re/sources/hydro-power), retrieved on 11.9.2014.
- [Pongas et al., 2014] E. Pongas, A. Todrova, G. Gambini. *Trade in energy products*. [epp.eurostat.ec.europa.eu/statistics\\_explained/index.php/Trade\\_in\\_energy\\_products](http://epp.eurostat.ec.europa.eu/statistics_explained/index.php/Trade_in_energy_products), retrieved on 4.9.2014.

- [Seeling–Hochmuth, 1997] G. Seeling–Hochmuth. *A combined optimization concept for the design and operation strategy of hybrid–PV energy systems*. *Solar Energy*, 61(2), 77–87, 1997.
- [Senyu et al., 2006] T. Senjyu, D. Hayashi, N. Urasaki, T. Funabashi. *Optimum Configuration for Renewable Generating Systems in Residence Using Genetic Algorithm*. *IEEE Transactions On Energy Conversion*, 21(2), 459–466, 2006.
- [Supriya, Siddarthan, 2011] C.S. Supriya, M. Siddarthan. *Optimization and sizing of a grid-connected hybrid PV–Wind energy system*. *International Journal of Engineering Science and Technology (IJEST)*, 3(5), 4296–4323, 2011.
- [Tazvinga, Hove, 2012] H. Tazvinga, T. Hove. *A techno–economic model for optimising component sizing and energy dispatch strategy for PV–diesel–battery hybrid power systems*. *Journal of Energy in Southern Africa*, 23(4), 18–28, 2012.
- [Tazvinga et al., 2013] H. Tazvinga, X. Xia, J. Zhang. *Minimum cost solution of photovoltaic–diesel–battery hybrid power systems for remote consumers*. *Solar Energy*, 96, 292–299, 2013.
- [Thiele et al., 2014] A. Thiele, T. Terry, M. Epelman. *Robust linear optimization with recourse*. [http://www.optimization-online.org/DB\\_FILE/2009/03/2263.pdf](http://www.optimization-online.org/DB_FILE/2009/03/2263.pdf), 2010, retrieved on 18th of August 2014.
- [Thomas, 2008] I. Thomas. *The Pros and Cons of Solar Power*. The Rosen Publishing Group Inc., New York, 2008.
- [UCSUSA, 2014] *Benefits of Renewable Energy Use*. [ucsusa.org/clean-energy/our-energy-choices/renewable-energy/public-benefits-of-renewable.html](http://ucsusa.org/clean-energy/our-energy-choices/renewable-energy/public-benefits-of-renewable.html), retrieved on 4.9.2014.
- [Umweltbundesamt, 2014] *Energie*. [umweltbundesamt.at/umweltschutz/energie/](http://umweltbundesamt.at/umweltschutz/energie/), retrieved on 8.9.2014.



- [U.S. Census, 2012] *United States*. <http://www.worldatlas.com/aatlas/populations/usadensityh.htm>, retrieved on 6.10.2014.
- [Winter, 2014] C. Winter. *Germany Reaches New Levels of Green-dom, Gets 31 Percent of Its Electricity From Renewables*. [businessweek.com/articles/2014-08-14/germany-reaches-new-levels-of-green-dom-gets-31-percent-of-its-electricity-from-renewables](http://businessweek.com/articles/2014-08-14/germany-reaches-new-levels-of-green-dom-gets-31-percent-of-its-electricity-from-renewables), retrieved on 10.9.2014.
- [WMI, 2014] *Operational and Maintenance Costs for Wind Turbines*. [windmeasurementinternational.com/wind-turbines/om-turbines.php](http://windmeasurementinternational.com/wind-turbines/om-turbines.php), retrieved on 12.9.2014.
- [Verma, Kumar, 2010] Y. P. Verma, A. Kumar. *Profit Maximization and Optimal Sizing of Renewable Energy Sources in a Hybrid System*. International Journal of Engineering Science and Technology, 2(9), 4575–4584, 2010.
- [Yang et al., 2007] H. Yang, L. Lu, W. Zhou. *A novel optimization sizing model for hybrid solar-wind power generation system*. Solar Energy, 81, 76–84, 2007.
- [Zhang, Li, 2011] L. Zhang, Y. Li. *Optimal energy management of hybrid power system with two-scale dynamic programming*. Proceedings of 2011 ASME Dynamic Systems and Control Conference, 247–254, 2011.
- [3tier, 2014] *Global Wind Speed Map*. [3tier.com/en/support/resource-maps/](http://3tier.com/en/support/resource-maps/), retrieved on 31.8.2014.