



MASTER-/DIPLOMARBEIT

DEMOLITION WASTE MANAGEMENT AND DESIGN FOR DECONSTRUCTION

**ausgeführt zum Zwecke der Erlangung des akademischen Grades
eines Diplom-Ingenieurs / Diplom-Ingenieurin
unter der Leitung**

Univ.Prof. Dipl.-Ing. Dr.techn. Ardeshir Mahdavi

E259

Institut für
Architekturwissenschaft

eingereicht an der Technischen Universität Wien

Fakultät für Architektur und Raumplanung

von

Eirini Pisti

0928216

Türkenstraße 3/303, 1090 Wien

My special thanks to :

My supervisor Prof. Ardeshir Mahdavi for his guidance during the evolution of this thesis.

I would also like to thank Prof. P. H. Brunner from the Waste Management Department for his valuable advice and support.

Moreover I would like to thank Mr. Heinz Buschmann, Mr. David Clement, Mrs. Kristina Schinegger and Mr. Bernard Sommer for their time to answer the questions of my interviews.

DEMOLITION WASTE MANAGEMENT AND DESIGN FOR DECONSTRUCTION

PISTI EIRINI

Department of Building Physics , Vienna University of Technology

Keywords: demolition, deconstruction, demountable structures ,toxic substances

Abstract

This thesis presents a systematic approach to the state-of-the-art in the demolition waste management field, by collecting information from the current related literature. In addition, it aims to find out whether and how the architectural design could play a part in applying more effective demolition practices contributing in the reduction of waste. The construction industry during the last decades has realized that the gradual depletion on natural resources should be seriously taken into consideration and the huge amount of construction waste, disposed as useless on landfills, should be treated and recycled so that environmental protection is achieved. Some literature references state that the huge amount of deconstruction waste is a problem which has resulted from the fact that construction has been following the linear building scenario. The linear scenario starts with the raw material extraction and ends with the demolition and the landfill of the material stream. Landfill is proved to be an unsustainable way to deal with the waste, not only because the material is not recovered, but also because the construction waste apart from stones, bricks and metals contains pollutant substances which cause soil erosion and air pollution both in the short as well as long term.

Because of the above stated problem, action has already been taken by recycling the demolition waste in some European countries. The second chapter of this thesis presents a detailed description of the available technology and methods to break down a building and segregate the inhomogeneous demolition debris into the initial construction materials. After the segregation, the separated materials may be disposed, incinerated recycled or reused. Disposal of waste leads to complete loss of it. Similarly incineration results to no material recovery. Recycling, on the other hand, leads to material recovery which, however, in most cases (ex. concrete aggregates) is "downcycled". Finally, reuse is the ideal waste treatment, which allows the saving on energy and raw materials. However the issue is how demolition waste may be reusable.

The third chapter deals with that issue by showing that we have arrived to having a huge waste stream due to the fact that buildings have not been designed with the objective of the reuse or recycling of the materials at the end of their lifecycles. The answer to this is a new design approach the "Design for Deconstruction (DfD)" aiming to transform buildings from fixed permanent structures into flexible ones with demountable components. These components will be reused after the deconstruction of the building. The European Union has established a set of standards urging the European member countries to recycle up to 70% of their demolition waste until the year 2020. Pilot programs for demountable buildings and the creation of an industry to produce recyclable materials are already under way in the highly industrialized countries like Germany, Netherlands and the UK. These practices should be applied in all European countries, so that in future the deconstruction waste is reduced.

The fourth chapter includes a series of interviews with waste management researchers and architects, working in Vienna. The interviews show the extent to which demolition practices can be applied as presented in the relative literature. They also reveal the obstacles in "Designing for Deconstruction", one of them being the lack of standards to guide such an innovative design concept. In addressing to the lack of standards, this thesis concludes by suggesting a list of design guidelines towards deconstruction.

TABLE OF CONTENTS

Abstract	2
1 INTRODUCTION	
1.1 Motivation	6
1.2 Research Background	7
1.3 Methodology	10
2 DEMOLITION WASTE MANAGEMENT OVERVIEW	
2.1 Definitions	11
2.2 Techniques for Demolition	13
2.3 Technology for Waste Treatment	18
2.3.1 The Sorting Process	19
2.3.2 Description of Waste Treatment Installations.....	20
2.3.3 Demolition Waste Treatment in the Installations	20
2.3.4 The Shredding Process	21
2.3.5 Separation from foreign (non-mineral) material.....	24
2.4. After the Treatment: Incineration, Landfill, Recycling	31
3 DESIGN FOR DECONSTRUCTION OVERVIEW	
3.1 Closing the building life-cycle loop	34
3.1.1 Why being less bad is not effective	34
3.1.2 Design for Deconstruction (DfD)	36
3.2 Detailing for deconstruction	40
3.3 General Principles towards no waste disposal	47
3.4 Deconstruction Planning.	48
3.5 Waste Management a European Overview.....	53
3.5.1 Demolition Contracts.....	55
3.5.2 Recycling Standards stated by the European Parliament.	56
3.5.3 A short overview of countries with the most comprehensive documentation.	58
4 INTERVIEWING EXPERTS	
4.1 Interviewing waste management researchers	69
4.2. Interviewing architects	79

5 RESULTS AND DISCUSSION

5.1 Conclusions on demolition waste management overview..... 87

5.2 Conclusions on design for deconstruction overview..... 87

5.3 Conclusions interviewing waste management experts..... 88

5.4 Conclusions interviewing architects 90

5.5 General Conclusions 93

6 REFERENCES

6.1 Literature 94

6.2 Web pages 96

6.3 Tables 96

6.4 Figures 96

chapter 1

INTRODUCTION

1.1.Motivation

The demand for sustainable structures is gradually becoming more pronounced as the environmental concern becomes stronger, the earth population tremendously increases and the global economic crisis forces constructors to reduce cost, save on energy and material waste in the construction process.

A large number of studies are proved that building demolition has a negative impact on the environment. The main problem of the demolition is that it does not allow material recovery and the material waste stream ends up to landfills. Lately researchers focus on the replacement of the conventional demolition practices with the selective demolition or deconstruction wherever applicable. Both methods result in material recycling reducing, thus, the depletion of natural resources.

The goal of this research is to give an overview of the current demolition practices and provide guidelines in the design of the buildings, so that they may be deconstructed in the future and their material stream may be recycled or reused. In fact, in the related literature architects and urban planners are urged to apply such design guidelines so as to contribute to improved demolition practices. If the theoretical background on Design for Deconstruction (DfD) is there, what prevents it then from being applied? Is it the ignorance of the designers concerning the negative consequences of conventional demolition or are there other economic, social and technical obstacles that still make it a preferable solution?

The literature overview and the information collected from the interviews will be used in answering the above questions and throw the light on the obstacles Design for Deconstruction encounters in in the daily design process.

1.2 The Research Background

A short overview of the demolition waste problem and the latest strategies dealing with it will be presented, along with their references here below. Several universities and research institutes are focusing their studies on the negative impact demolition waste has on the environment and search for constructions less environmentally harmful and more adaptable to rapid socioeconomic changes.

Definition of the demolition waste problem

During the years that followed the industrial revolution an extensive extraction and use of raw materials took place in order to serve the purposes of mass production. During that time there was no provision for waste recovery. Figures 1.1 and 1.2 illustrate the observation above made.

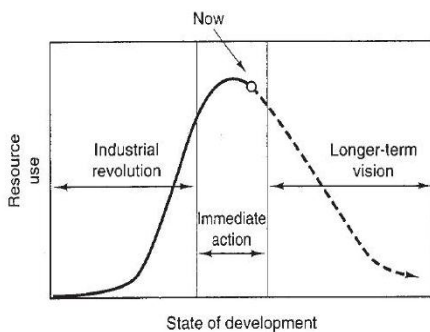

Figure 1.1. The diagram depicts the relation between the state of the technological development of society and the consumption of natural resources (Greadel and Allenby 1996)

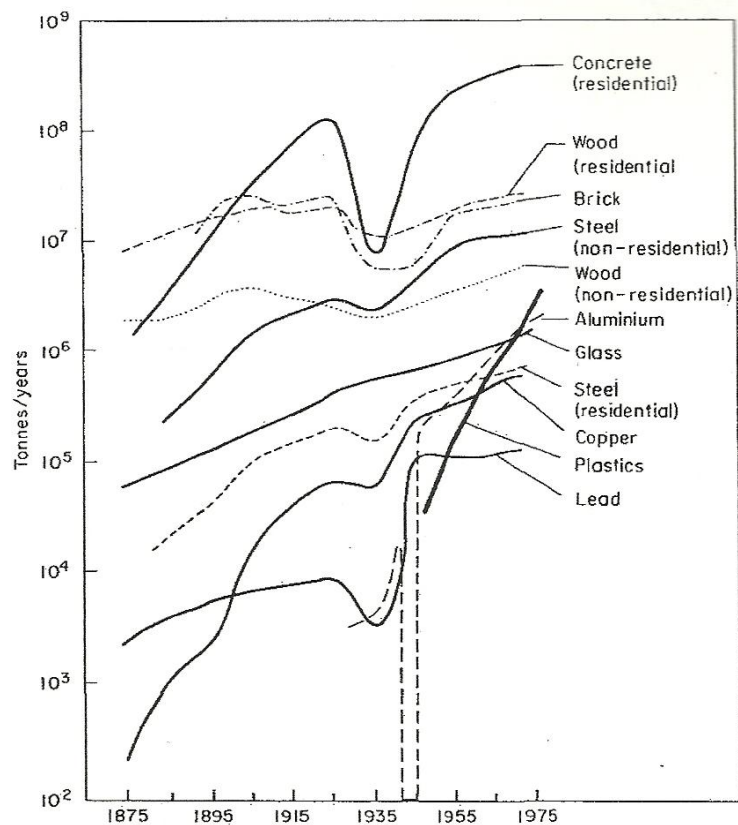

Figure 1.2. Materials used in the USA the last century (Wilson 1990)

Observers of current and future trends predict that the 21st century is the beginning of an era that will be marked by temporary, multi-functional building performance. Buildings are commonly regarded as long permanent structures and therefore designed with their components fixed on the core structure.

" However, the conventional building industry has a limited understanding of building efficiency. Buildings are conceived as fixed and permanent structures although they may be subject to daily transformation. For that reason most building structures have to be broken down, in order to be changed, adapted, upgraded, or replaced. Their material flow is one-directional, starting from material extraction, and finishing with landfill. This results in huge waste production and material consumption. Buildings are commonly regarded as long permanent structures and therefore designed with their components fixed on the core structure." (E. Durmisevic 2006)

During the last decades of mass industrialization and urbanization it was taken for granted that buildings were long-life permanent structures and a little thought was given as to how all the material assembled on the structure would be treated when blocks of urban buildings were to be broken down. That was happening because materials and structural components were designed to be mounted with no consideration for them being demountable.

At the end of the building's life cycle, demolition still remains the most rapid and cost effective way to get rid of an old structure. It requires some bulldozers and explosives to transform the building into a mass of fragments. Demolition however is proved to have very negative effects on the environment.

Why is demolition harmful?

1. Many studies have proved that the construction industry is the biggest consumer of natural resources and energy globally, as well as the biggest dumper of waste.

The demolition of buildings produces enormous amounts of waste materials. In most countries this results in significant waste streams. In the U.S. demolition waste represents to 92% of the total construction and demolition waste streams. (C.Kibert 2000)

According to Eurostat statistics the building industry in Europe produces 450 million tonnes of waste per year, with yearly increases of 9.7 million tonnes.

Recent estimates indicate that existing buildings account for:

- 40% of energy consumption
- 50% of material resources
- 40% of waste production

2. Apart from the excessive use of raw materials and the increase of the demolition waste during the last century, the embodied energy loss is a supplementary problem is when the debris ends up to landfills. As Elma Durmisevic describes in her PhD "Transformable buildings structures:

" Embodied energy is the energy required to produce or manufacture a product. This includes:

- *Direct energy used in the manufacturing process,*
- *Indirect energy required to extract raw materials, transport them, and*
- *Energy needed to produce the infrastructure required for these production activities."*

(E. Durmisevic 2006).

When the demolition debris is directly disposed without any treatment for reuse or recycle, not only the materials, but also the embodied energy used for their production is disposed of in the landfill.

3. For centuries construction and demolition waste was mostly consisted of virgin material: stone, brick, steel and wood. After demolition, the debris was either landfilled or burned in the incinerator to produce energy.

After the decade of 1940 new materials like: aluminium, plastics and organic compounds were introduced changing the quality of the demolition stock. Construction waste of the 1970s was containing small, but increasing numbers of plastic and metal fragments (Wilson 1975), which themselves contained a considerable amount of energy for their manufacture. The chemical behavior of the new organic substances (mainly plastics) when landfilled is different than that of virgin material. Also certain of them are regarded hazardous as they denature the soil consistency and pollute the aquifer. Such hazardous materials are paint, coatings, anti-fouling agents, fungicides etc. These materials should receive special treatment before their landfill (P.H. Brunner & M. Stampfli 1993).

It was in the beginning of the 90' s when the arising concern about environmental pollution resulted in the taking measures for the treatment of the demolition debris (DGXI European Commission 1999).

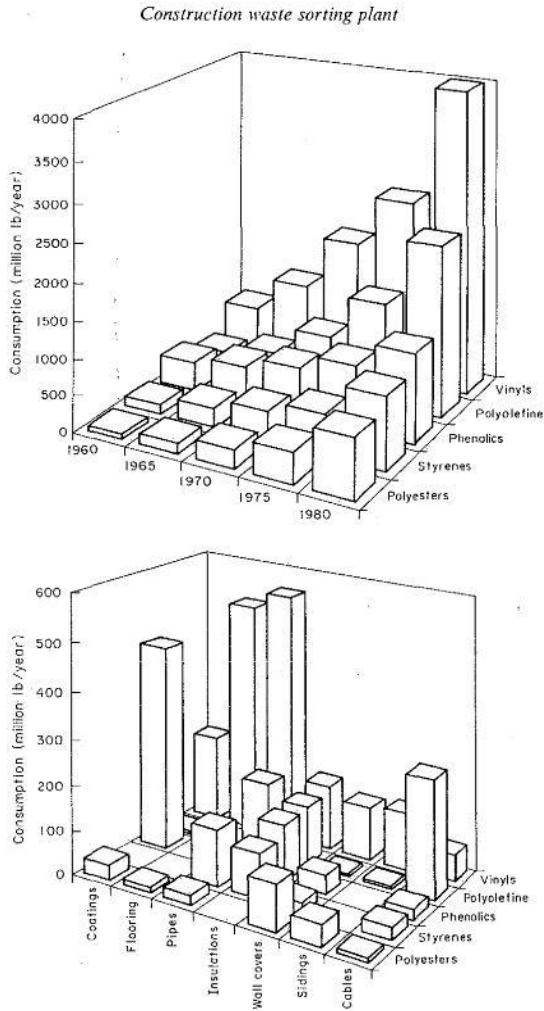

Figure 1.3. Use of plastics for various construction purposes: (a) estimated consumption of specific plastics in the US in the years 1960 - 1980, (b) use of selected plastics for main purposes in 1970 (Rosato 1972 and Stahl 1972).

1.3 Methodology.

Being aware that the disposed waste has an immense environmental negative impact, the target of this thesis is to present the state of the art of the demolition waste treatment and to point out the potential contribution of architectural design in reducing the construction waste in the future. The findings of the research are based on information acquired from several journals and literature sources, which describe tools and techniques used in different European countries to treat the demolition waste. The literature overview is enriched by interviews with experts in the waste management field and with energy design architects. The methodology is structured in three steps

[1] The first step aims to collect literature data on the demolition waste treatment practices and to identify the problematic areas of these methods, in order to optimize them in the future.
[2] The second step is the collection of literature data about the Design for Deconstruction, a design concept for structures whose material stream is to be reused at its entirety after demolition.
[3] The third step is the taking of interviews with architects and waste management experts to enrich and prove the feasibility of the literature findings in practice.

Each step is covered by a whole chapter, more specifically step [1] in chapter 2, step [2] in chapter 3 and step [3] in chapter 4. Chapter 2 answers to the following questions:

- What demolition techniques are available and how do they differ from each other?(description of conventional demolition, selective demolition and deconstruction)
- What technological tools do we have in our disposal to treat the waste after it is created? (crushers, sieves, dry and wet classifiers)
- Which materials, recovered from the debris, are recycled, incinerated or landfilled? What are the disadvantages of these techniques as far as material reuse is concerned?

Chapter 3 deals with design for deconstruction and material reuse. Deconstructing a building by demounting and reusing its components is a more sustainable waste treatment method than landfill and incineration presented in chapter 2. The present chapter intends to answer the following questions:

- What is Design for Deconstruction (DfD)?
- Are there any guidelines for Design for Deconstruction in the literature?
- Are there any official standards for Design for Deconstruction?
- What waste management strategies the various European countries use? Are there any well documented case studies on design for deconstruction?

Chapter 4 intends to find out the feasibility of design for deconstruction. The interviews took place in Vienna and involved waste management researchers and architects. Questions towards waste managers aimed to find out:

- what demolition practices are applied in everyday practice in Vienna?
- what are their advantages and disadvantages?
- what are the main obstacles to apply more sustainable demolition practices than conventional demolition such as selective demolition or deconstruction.

Finally, interviews with architects aimed to find out :

- is demolition taken into consideration at the design phase?
- Are architects aware of the guidelines presented in chapter 3 about DfD?
- Which are the main impediments to apply these guidelines on the current design process?

chapter 2

DEMOLITION AND MATERIAL RECYCLING

This chapter describes the most common tools for demolition and demolition waste treatment. In many cases on a global level the conventional demolition has been replaced by the selective demolition. In selective demolition components are removed from the building before it is demolished and treated as toxic waste, while reusable components are salvaged from the debris. The demolition waste treatment takes place in specific treatment installations, where the mineral material (stone, ceramics, concrete), the wood, the metals and the plastics are separated from each other with the use of classifiers.

2.1 Definitions

Demolition is the process, whereby a building is broken down and the created demolition debris ends up to landfills without previous treatment for reusability.

Selective Demolition is the process, whereby reusable and toxic components are removed from the building before it is crushed.

Deconstruction is the dismantling of a building so that all of its parts can be reused.

Recovered material is the material extracted from the demolition debris in a state that it can be used for the same function again.

Reuse The use of recovered materials for their original purpose.

Recycling is the manufacture of a new product using recovered material, scrap or waste feedstock

Upcycling taking a low grade material and turning it into a high grade material

Downcycling taking a high grade material and turning it into a low grade material.

Material Waste arising from building Industry

The waste related to the building infrastructure derives from both construction and deconstruction processes. In particular one could describe the sources of construction debris as follows(CIB 2005):

- Waste produced by partial or total building demolition or civil infrastructure
- Waste produced by construction of buildings and civil infrastructure
- Waste produced by excavations for land leveling and general civil works
- Waste produced by road planning and road maintenance.

A. Soil Waste

It is the sort of waste containing native material extracted from the construction site. It is composed by soil, rocks, sand, clay and other materials. It causes no contamination because it is consisted of the same composition as the ground (Brunner P.H. & Stämpfli M. 1993).

B. Inert Waste

Resulting from construction or deconstruction that kind of waste includes pure concrete fractions (without reinforcement), brick fragments and masonry. Inert waste is considered to have "final storage quantity", that means it can be landfilled without pretreatment. *"A material has final storage quantity when it is in equilibrium with natural environment and when its leachates in a landfill do not change the geogenic fluxes and reservoirs"* (Baccini 1989)

C. Construction Wastes

Mixture of various inert and reactive materials which compose the demolition mass. The mixture includes concrete, bricks, wood, plastics and metals. In some cases this mixture contains paints, surplus materials and leftovers resulting from renovation and construction processes. The composition of this mixture may vary according to the location and the construction site. These waste requires pretreatment or long term control within a landfill for leachates and landfill gas.

D. Hazardous construction waste

Hazardous waste contains contaminated materials which include organic and inorganic chemicals like paint, coatings, anti-fouling agents, fungicides etc. This type of waste should not be landfilled before previous treatment and for each pollutant type there is a different guideline. Pollutants are classified into four categories according to their toxicity dispersed in the environment as shown in the table below.

Group 1 (pollutants the most toxic)	As, Sb, Cd, PB, Hg, Se
Group 2	Ni, Cr, Mo, phenol
Group 3	Fluorides, Cu, Zn, Ba
Group 4	Sulphates, Chlorides, DOC

Table 2.1. Table with hazardous construction materials . (Roussat, Dujet, Méhu 2008)

2.2 Techniques for Demolition

The most common techniques are the following (Raess et al. 2003):

1. Crash with metal ball hanging from crawler crane
2. Use of explosives
3. Pulling with tractor and cable.
4. Pushing with hydraulic machine Unit
5. Tearing with hydraulic crane
6. Grabbing and pulling with pliers and scissors
7. Down leveling with drills and hammers
8. Demontage

1. Crashing with metal ball hanging from crawler crane

To break down buildings the metal ball weighting from 0,5 to 5 tons hangs with a rope from a crane and collides with the structure by oscillating movements. Oscillation results in parallel crushes, while the vertical crushes are achieved by freefall of the metal ball on the building mass. This technique does not respond anymore to the contemporary technical standards. It is recommended mainly for heavy masonry. The maximum height of the rope with the crane should not exceed the 50 m and the distance of the metal ball should be minimum the 40% of the building height to be sufficient for the oscillation.

Advantages:

- cost convenient method
- high efficiency
- limited workforce and machinery

Disadvantages:

- large broken pieces which require further crushing
- arising noise, dust and vibrations disturb the surrounding area
- danger of injury from the falling debris

2. Use of explosives

This is the most commonly used method to demolish a building structure. The explosives are inserted in previously specified holes created with a drill in the building mass. The most critical point of this method is the correct position of the holes and the quantity-quality of the explosive material in order to eliminate the danger of the explosion. The explosion demolition technique is suitable for masonry and concrete structures, however in some cases strongly reinforced concrete components might not be exploded as expected.

Advantages:

- very fast
- high efficiency
- no need for static calculations

Disadvantages:

- large broken pieces which require further crushing
- arising noise, dust and vibrations disturb the surrounding area
- danger of injury from the exploded elements
- required explosion authorization

3. Pulling with tractor and cable.

This method can pull down specific walls or components of the structure or even the whole buildings itself depending on the structural frame of the construction each time. Excavators, bulldozers and winches can be used as pulling machines. Mini excavators can be efficient in pulling down specific walls or other components from the interior without pulling down the whole structure. This method is applicable for masonry walls, concrete structures with light reinforcement and frame-based structures.

Efficiency rating with winch : 2-4 m³/h

Efficiency rating with tractor: 5-10 m³/h

Advantages:

- high productivity
- fast application on the construction site
- high quality material selection using the mini excavator.

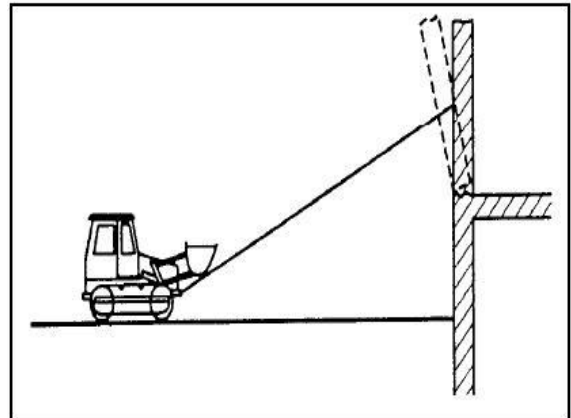

Figure 2.1. Pulling with tractor and cable (Osebold 1981)

Disadvantages:

- strong damage of the cables because of the pulling
- the falling parts of the inner structure pulled down by the mini excavator must be supported by the rest of the structure

4. Pushing with hydraulic machine Unit

With the hydraulic machine the walls of a building are gradually demolished. The procedure is always directed from outside to inside. The height of hydraulic arm should reach the total height of the building in order to keep the process under control. For this process is usually used a crane with a shovel on top. This process is used for buildings with max. height 25m made of masonry, concrete with light reinforcement or wooden structures.

Efficiency rating: 20-40 m³/h

Advantages:

- limited workforce and machinery
- limited functional space at construction site (6m next to the building)
- The crane with the shovel can serve for the assembling of the debris.

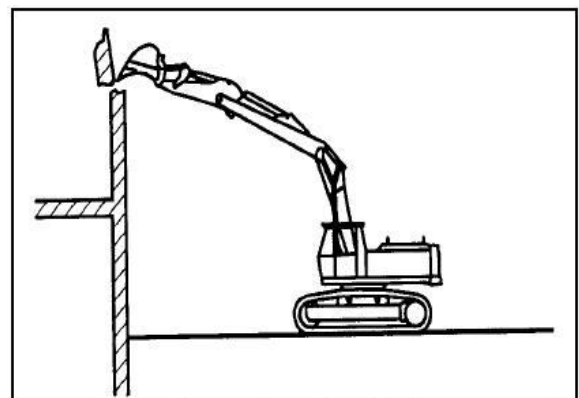

Figure 2.2. Pushing with hydraulic machine unit (Osebold 1981)

Disadvantages:

- limited Material selection
- arising noise and dust disturbing the surrounding area
- the stability of the building is harmed because of vibrations

5. Tearing with hydraulic crane

This technique takes place the opposite way of the previous one. A telescope structured demolition stick with a hook at the end pulls the walls down from the inside to the outside direction. The demolition stick can reach a building height of 25m. maximum. An hydraulic crane supports the stick structure and supplies it with the necessary energy to tear the the walls apart. The method of the telescope stick is used to demolish masonry, concrete structures with light reinforcement and wooden structures.

Efficiency rating: 20-40 m³/h

Advantages:

- limited workforce and machinery
- The crane equipped with an extra shovel can serve for the assembling of the debris as well.

6. Grabbing and pulling with pliers and scissors

This method is applied on the deconstruction sites for a long time period. Similarly to the previous demolition methods, a crane supports a metal arm with grippers, pliers or scissors on top. The pliers and the scissors can succeed in strong cuts of the building components even of the ones with heavy reinforcement.

In masonry structures sorting grippers contribute in an efficient material sorting during the demolition. The operation proceeds gradually downwards without effecting severely the building stability through vibrations and debris freefalls. An experienced crane operator can select specific building components (ex. windows, doors, staircases) and detach them from the main structure in a few minutes.

Advantages:

- good material selection
- The crane equipped with an extra gripper can serve for the assembling of the debris as well.
- limited noise and dust arising from the process.
- not severe vibrations to harm the main structure

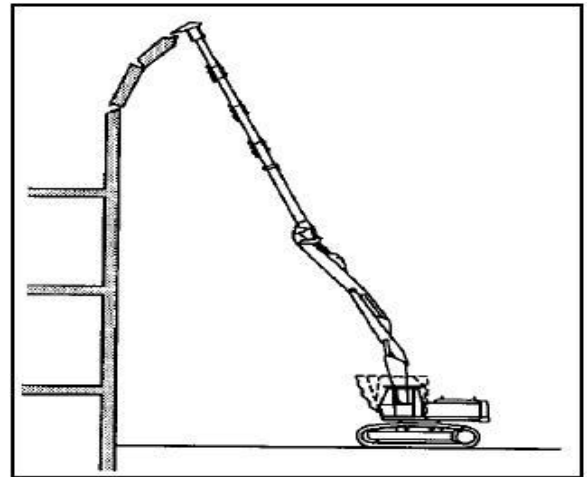

Figure 2.3. Tearing with hydraulic machine unit (Osebold 1981)

Disadvantages:

- limited Material selection
- arising noise and dust disturbing the surrounding area
- the stability of the building is harmed because of vibrations
- large space required for the demolition procedure

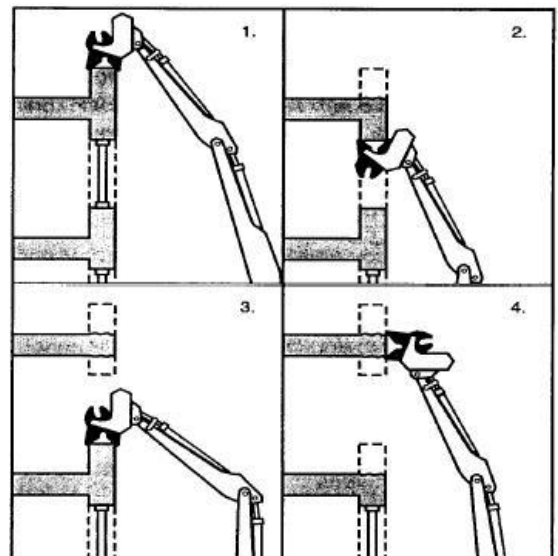

Figure 2.4. Grabbing and Pulling with pliers and scissors (Abbruch Handbuch 1985)

Disadvantages:

- a big number of workforce and machinery required
- pliers and scissors severely damaged
- limited time effectivity

7. Down leveling with drills and hammers

The demolition technique of this type proceeds downwards in two possible ways: either with small manual drill-hammers or with a drill mounted on a hydraulic crane. The manual drills are mainly used for the higher parts of the building to break mainly masonry and light reinforced concrete. The machine based drill is used for the lower parts of the structure.

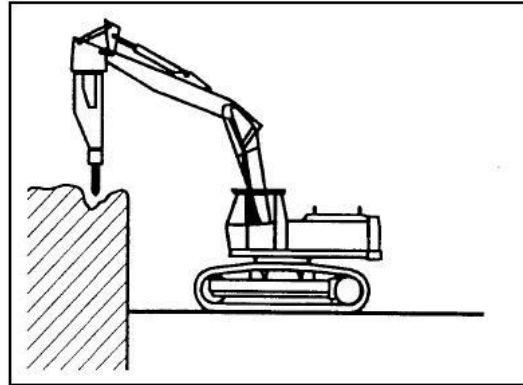

Figure 2.5. Down leveling with drills and hammers (Osebold 1981)

Advantages:

manual

- high quality of material selection
- limited space around the building for the operation required
- not severe vibrations to harm the main structure

with machinery

- highly time effective

Disadvantages:

manual

- time consuming
- large number of working staff required
- accident high probability

with machinery

- limited material selection
- operation limited by the building height
- auxiliary space required next to the building

8. Selective Demolition

The selective demolition is a step beyond conventional demolition. Within this process building material which can be reused or needs special treatment (ex. asbestos a toxic substance included in plaster of older buildings), is removed from the building before the demolition starts. The successive stages of selective demolition are presented below:

Stage one: First, stripping of the building of reusable components takes place. Such components include radiators, sanitary fixtures, wooden floor finishes, doors and windows (Durmisevic 2006). Second, components which are possibly contaminated by the hazardous material they contain are also removed from the building mass. Such components are plastering containing asbestos [$Mg_3Si_2O_5(OH)_4$], pipes or service installations containing toxic metals like lead [Pb] and cadmium [Cd] and flat roofs. Flat roofs are usually contaminated by the PAH (polycyclic aromatic hydrocarbons) and should be treated as chemical waste.

The different arising waste streams are transported to a sorting plant and divided into recyclable, burnable and non-burnable materials. The burnable part is burned in a waste incinerator while the non-burnable is either recycled or landfilled.

Stage two: After having stripped of the building of the reusable or toxic components, only the brickwork and concrete is left. This is when demolition starts floor by floor. Brickwork is cut into pieces and transported to a crusher plant. Most of the brick is not reusable because of the strong mortar that breaks after the brick itself.

Wooden floors and beams are removed with cranes and equaliser beams, while the nails in the joints are taken away by punching.

In concrete structures, the concrete frame of the building is cut up by breaker shears and later taken to the crusher to be turned into small fragments for later use or landfill. In the crushing planting the steel embodied in the concrete for reinforcement is extracted by magnets.

In steel structures, the demolition depends on the structural elements and their joints. If the joints are mechanical the beams and columns can be disassembled and reused in future, otherwise the structure is cut up and sent to steelwork.

9. Deconstruction

The demontage or in other words the process of demounting a building to its initial components, so that they can all be reused, is the most sustainably ideal scenario of deconstructing a building in order to avoid waste. It is a process which is partly realised with selective demolition, but still the big challenge for a total demontage is that it is almost impossible, if the building was not designed from the very beginning to be disassembled when it's life cycle will be ended.

Steel and wooden structures are easier to be deconstructed with demontage, but heavy masonry and concrete structures need a more carefull examination. The benefits and impediments related demontage will be in detail described in chapter 3.



Figure 2.6. Building components of the Lustron-house, Albany, New York (Westra J.1990)

2.3. Demolition Waste treatment

The main purpose of the material debris separation is to isolate the mineral materials (stone, gravel, bricks etc) which constitute usually the 85%-90% of the building mass, from other components of different materiality like wood, metal, synthetic material etc. This separation is achieved by sorting at the construction site and classification of the debris in treatment installations. Sorting and classification are described in brief below:

- The **sorting** stage takes place at the deconstruction site. The building debris is broken down to pieces which are separated and put into containers according to their size. At this early stage some non-mineral components of a big size like wooden staircases or balconies, radiators etc. are removed from the untreated building mass. The debris classified in containers will to be sent for further elaboration in the relative demolition treatment installations.
- The second stage of the treatment takes place in the installations and is called **classification**. First the mixed material passes through the crusher to be fragmented in smaller pieces and then it is sieved. Finally it is classified into different aggregates according to their size and physical characteristics. For this particular stage a wide range of linear or circular motion machines, finger screens and span wave sieves is implemented. These devices classify the material fragments according to their size and density. The process is essential to achieve a higher quality of separated aggregates . The selection of the separation process defines the quality of the final product or vice versa.

Both processes are carried out by removal of non mineral material. Removal techniques involve either hand or machinery support. The picture below depicts a typical residential waste composition. As one can observe the biggest percentage is consistent of minerals (brick, stones and concrete) while significant is also the percentage of the gypsum/mortar and the organic wood. Metals and plastics concern the small remaining percentage. Metals are removed from the debris by magnets, mineral are heavier than wood and plastics so they can be separated in the classifiers. The goal of the classification process is to isolate the materials below into fragments as pure as possible for further reuse, recycling landfill or incineration.

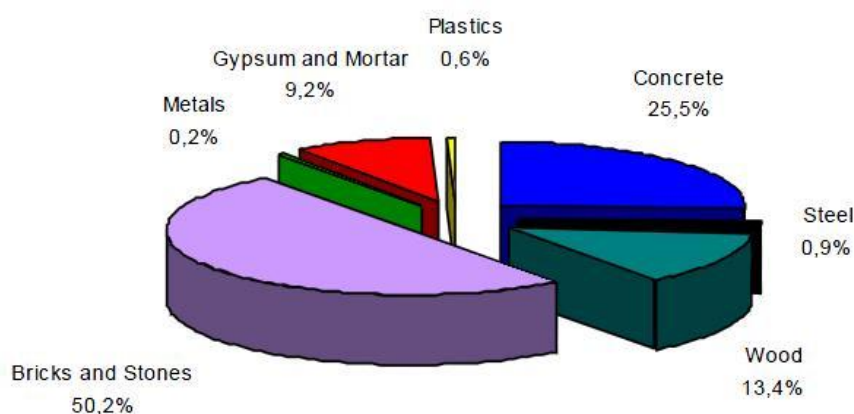

Figure 2.7. Composition of residential waste (CIB 2005)

2.3.1 The sorting process

Manual Process: The process takes place at the construction site where the broken down building fragments are thrown on a rolling band and manually non-mineral components are extracted. The manual process concerns components with a maximum weight 10kg. For components which exceed the aforementioned weight the use of dippers and grippers is recommended (Raess et al. 2003).

Manual Process with Machinery support: For homogeneous components such as radiators, wooden balconies or staircases, steel beams etc. dippers and grippers are used. This process requires human handling. An experienced user of the gripper can grab efficiently the building components from the building debris and place them in the containers. This procedure is the first bulk separation of the building debris before fragmentation of the demolished components takes place. The extracted pieces end up in containers in order to be taken later on for further process.



Figure 2.8. Manual sorting (Rentz, Seemann, Raess, Schultmann,2003)



Figure 2.9. Sorting with grippers (Rentz, Seemann, Raess, Schultmann,2003)

Automated removal process: Automating the classification process with machinery support started in the very beginning with the use cameras and lasers, which were implemented in laboratory experiments identifying the big sized wooden and synthetic material through their position and geometry within the demolition debris. This method was later evolved in technologies which had the possibility to recognise more materials like cables and other residue. This advanced technology is equipped with a touch screen which requires the presence of a person to handle the gripper through the screen.

Recently the extraction of non-mineral materials was further optimized with X-Ray systems, similar to the ones used in airports to control luggage. Pneumatic pulse is also implemented in some cases, as well as magnetic fields. Through magnetic fields electricity is induced. According to their conductance metal components are identified and extracted from the building debris. These technological innovations are however quite expensive for the moment. Only when the treatment costs will be less than 5 to 10 Euros per ton, will this technology be implemented on a larger scale.

2.3.2 Description of waste treatment Installations

Mobile Equipment

Mobile rubble treatment installations are more easily built up than the stationary ones⁶. The structural parts of these installations are based on two axes trailers. Mobile installations are usually set up when the mineral demolition waste is found in large quantities, in cases like industrial building demolition highway bridges. For material waste less than 5.000-10.000 tones it is not profitable setting up mobile installations.

Semi mobile equipment

The semi-mobile installations are mounted on steel frames which are equipped with runners. To move the installation, its structural components have to be demounted and loaded on a trailer. Years of experience have proved that mobile as well as semi-mobile installations require foundation to reinforce their stability.

Stationary equipment

The size of the permanent installations is similar to the one of the mobile ones. They produce better end product quality. The demolition waste is carried with trucks. Their use is beneficial when demolition waste exceeds 100.000 t/a. (Raess et al. 2003)

2.3.3 Demolition waste treatment in the installations

When the demolition debris is removed from the construction site to the waste treatment installations, its destination is going to be the fragmentation for the creation of aggregates. The waste treatment process aims to optimize the consistency of the aforementioned aggregates in order to make them suitable to be reused, recycled or landfilled. These aggregates will be separated into mineral and non-mineral compositions through dry and wet classification techniques, which will be later described in this chapter. The quality of the final classified aggregates depends on:

1. the treatment technique. The higher the purity of the end product the more time consuming the purification process and vice versa.
2. the quantity and composition of the input material.

The separation of the demolition waste into mineral and non-mineral materials, in other words the purification process, takes place by the following steps:

- a) Material Input
- b) Preliminary Screening
- c) Shredding
- d) Magnetic Classification
- e) Mechanical Sorting

2.3.4 The Shredding Process

The previously mentioned demolition waste installations are divided into three components: The shredding, the classification and the sorting department. The process of the highest importance is the shredding though. Then the classification of the shredded fragments takes place. Stationary and semi-mobile installations are also equipped with purification devices to separate the mineral from the non-mineral materials. All type of installations are equipped with building waste treatment machinery: crusher units, metal separator, screening units and conveyors.

During the shredding process different types of crushers are used like: Jaw Crusher, impact-roller crusher, hard crusher, and hard mills. Shredding is necessary when breaking hard or semi-hard materials ex. in cases of road demolition debris. The hard crusher with its triple shredding capacity is proved much more effective than the other types(Raess et al. 2003).

Jaw Crusher and impact crusher are used for pre-shredding in most cases. In small installations the pre-shredding can be replaced by an hydraulic dipper with a rock chisel, this way the components whose size is too big will be cut into pieces.

Jaw Crusher

These crushers are mainly used in stationary installations as the first step of the shredding. For this process double and single toggles are used. Jaw Crushers can also be found in mobile installations.

Because of their low productivity in building debris fragmentation jaw crushers are used in pre-shredding. Their lifespan reaches 1-1,5 years (about 300.000 tones).

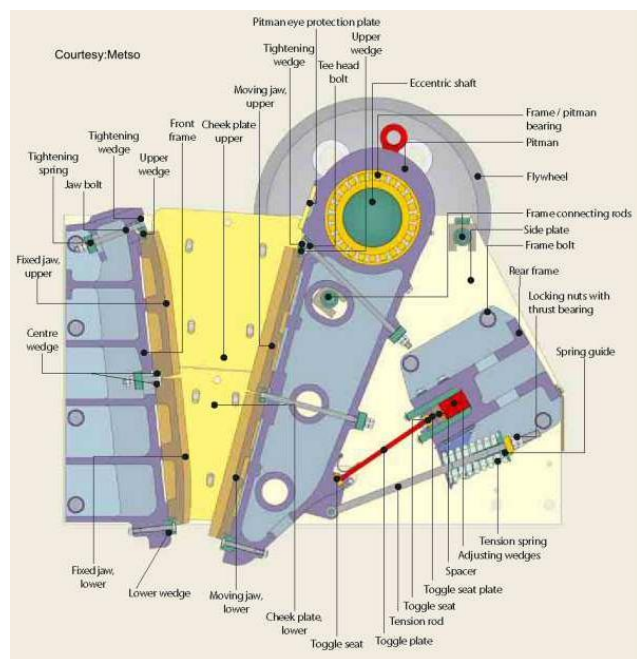

Figure 2.10. Jaw crusher
(<http://www.jawcrushermanufacturers.com>)

The Impact Crusher

The impact crusher is the main device where the shredding of the demolition debris takes place. It functions with strokes against the hard plates. This technique is much more effective than the Jaw Crusher. The grade of fragmentation doesn't depend on the gap, but on the velocity of the crushing plates. In the hard crusher the input waste according to its frangibility results in an outcome divided in two categories: rough and fine fragments. On the contrary in the jaw crusher all materials will pass through the jaw-gap in order to be equally shredded regardless of their hardness.

Impact-crushing is a financially convenient method that requires a few maintenance cost. The lifespan of the crush bars of a hard-crusher for the second breaking stage reaches the 10.000 tones, and for the first breaking stage 3.000 to 5.000 tones.

The-roller crusher

Roll crushers are consisted of two or more adjacent rolls positioned parallel to each other. The rolls rotate in opposite directions. Single roll crushers are also available, rotating a single roll against a fixed breaker plate. Mineral or rock particles are crushed as they pass between the rolls. The distance between the rolls is adjusted by nuts at the end of one of the rolls. Some rollers are toothed because corrugated surfaces offer better friction than smooth ones.

Theoretically, the maximum reduction ratio of a roll crusher is 4:1. For example, the smallest size that can be recognized by a particle of 2 inches is 1/2 an inch.

Applicable material:

- 1) Clay
- 2) Shale clay
- 3) Coal gangue
- 4) River silt

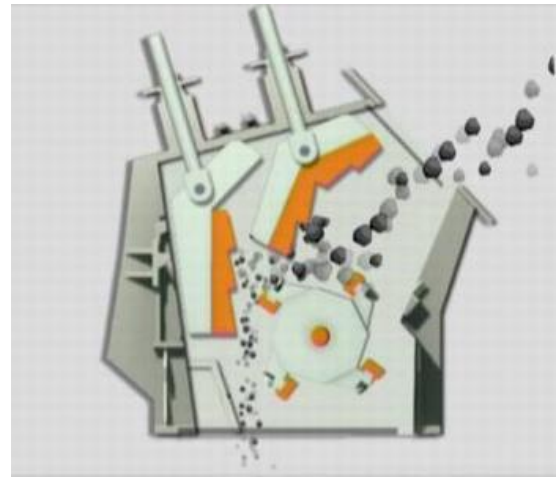

Figure 2.11. Impact crusher (<http://www.break-day.com/ver3.0/how/5.htm>)

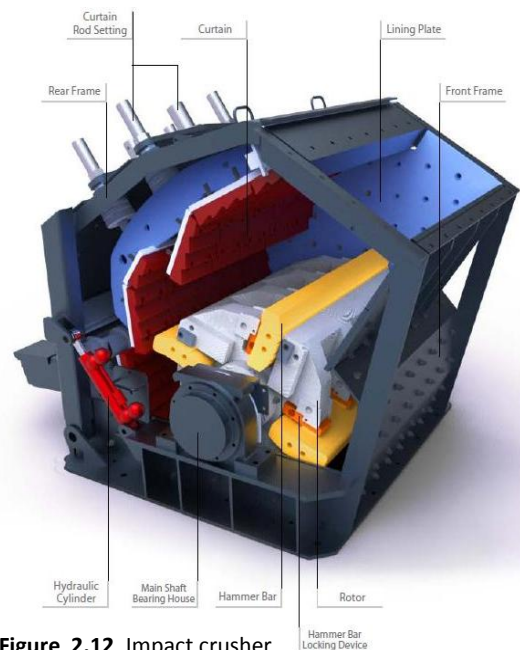

Figure 2.12. Impact crusher (http://www.stonecrusher.org/stonecrusher1.0/crushing_machinery/impact-crusher.html)

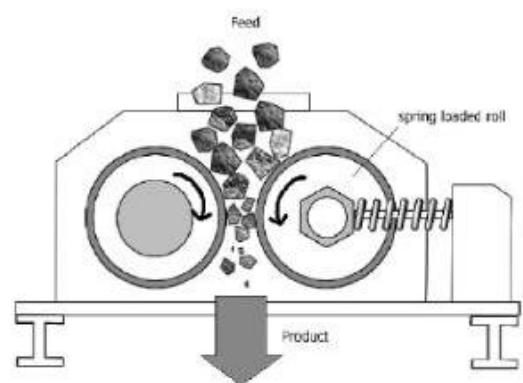

Figure 2.13. roll crusher (<http://www.scribd.com/doc/30156582/Chapter-6-Roll-Crushers>)

Cone crushers

The Flat cone crusher is an expanded shredding machine used both for pre and after shredding of mineral materials. The core of this crusher is the eccentric cone crusher axis, the lower part of which when rotating makes an oscillating circular movement which pushes the material to be broken against the crushing mantel to shred it into pieces.

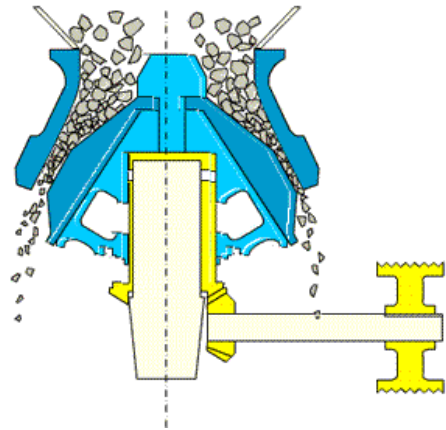

Figure 2.14. cone crusher

(<http://www.hjcrusher.com/2-cone-crusher-7.html>)

Crushers in conclusion

In general practice has proved that for limited amount of material debris one stage-treatment installations are used. On the contrary for larger quantities two stage treatment (before and after crushing) installations are recommended.

- One-stage installations use the Impact Mill as a universal crushing device for debris which exceeds the 150.000t/year
- Two stage installations use either jaw crusher for the first breaking, or the impact crusher for the after breaking for debris quantity which exceeds 100.000t/year, or the roll crusher for the first crushing and impact crusher for the after crushing procedure, this concerns debris quantities which exceed the 120.000t/year.

2.3.5 Separation from foreign (non mineral) material

Before or after the shredding of the debris takes place, the removal of non mineral components is very essential to achieve a higher quality of separated aggregates (Schultmann et al. 2003) . The selection of the separation process defines the quality of the final product.

The Classification Process

The classification or sieving process in the waste treatment installations is the process where the demolition debris is classified in categories. This process takes place in two phases: the **Pre-screening** and the **sieving phase**.

At the pre-screening process the untreated input material is going to be sieved in order to be separated from the fine or middle size fragments that it contains.

The rest untreated pieces of the input material proceed into the shredding phase. After the shredding, the broken material is going to be sieved again. To classify the input material the most important characteristic is the size of the fragment. Thus, the shredded material is divided into several aggregates according to the size of their fragmentation.

The gradation of the sieving depends on the type of the machine and the physical properties of the input substance. In some cases, in order to have finer aggregates, machines with a triple sieving net of different dimensions is feasible. The air humidity can also influence very fine grains. Though there is no standardized gradation, the resulting aggregates are classified according to the most commonly used industrial sizes.

The sieving process provides aggregates with similar fragmentation size, but doesn't enable the separation between mineral and non mineral material. Material sorting is necessary after having achieved equal size grains.

Magnetic classification

Removing the metal fragments mostly resulting from the reinforcement of the building is achieved using magnets. Magnets are usually placed behind the shredding units, that means they deprive the material debris of its metal components at the highest possible extend before the fragmentation takes place.

Magnets are usually placed on rolling bands running over the material debris with a low speed of less than 2m/s and with a low height in the horizontal or vertical direction of the rolling bands transferring the material to the waste treatment units. Depriving the building waste of its metal fractions is very essential to improve the quality of the end product.

Insufficient magnet sorting units result in production downtime, wear of the conveyor belts and the sieving units.

The function costs of the magnet removers is quite low and therefore their efficiency is expected to be high. This means the removal of metal components from the debris should exceed the 95% of total content in metal elements.

Mechanical sorting

During the procedure of separation between mineral and non-mineral fragments dry and wet classifiers are used. The function of the classifiers is explained in detail below.

Dry classifiers: Wind classifiers

The wind classifier is the most commonly used dry classifier (Schultmann et al. 2003). It separates the heavy mineral material (stone, brick etc.) from light non mineral (wood, plastic, etc.). There are two different techniques to implement the wind classifier, the cross flow and the counter flow technique. The most important advantage of the wind classifier lies in its independence from cleaning water and this way sewage sludge is avoided, plus the independence from the production of frosting. However this classification technique requires great air quantities and high energy consumption.

The material separation principle is based on the difference between the movements of the material fragments in the gas fluids. The most influencing parameters of the separation procedure are: the size, density and form of the fragments, the density and speed of the air flow, the concentration of the material particles and the geometry of the classifier. The particles whose gravity speed is lower (light material) than the airflow speed are entrained by the flow, while the particles whose gravity speed is higher than the speed of the airflow respectively to the construction will follow an orbit vertical to the airflow direction or simply fall down surmounting the airflow.

Before the classification process takes place a pre-classification of the material according to their density and fragmentation size is essential in order to have the best outcome. The fine fraction* as an input material is the best way to achieve a high quality of the classified material. The most commonly used input aggregate appear the following sizes: 8/16, 16/24, 24/32. Praxis has proved that wood and light material are easily separated by the air classifier, something which is not in force for metals.

1. Counterflow air classifier

The counterflow classifier's technique functions as shown in the picture below:

The mixed aggregate is inserted through a side plate in the pipe. Then it is exposed to the counter airflow within the pipe. The heavy mineral material surmounts the airflow and falls down on an underlying band, while the light material is carried away by the air flow.

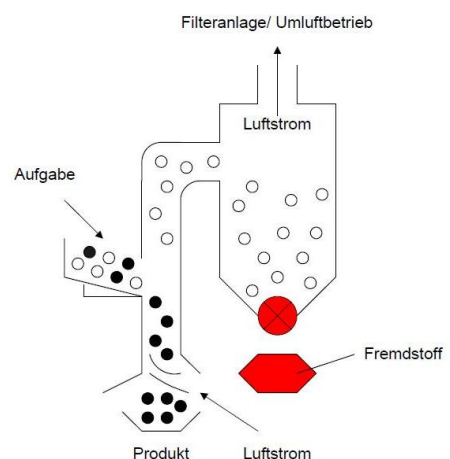

*Fine fraction refers to an aggregate whose smallest fragment is 0-8mm smaller than biggest fragment.

Figure 2.15. Counterflow classifier (Bilitewski 1995)

2. Cross flow classifier

The photo below shows the function of a countercurrent air classifier. The input material is inserted directly in the classifier through a vibration feeder and exposed to a countercurrent airflow which reaches the material under a 90° angle approximately. The airflow removes the light material from the mixed input aggregate. The light material is blown away in a side room. The benefit of the counter flow classifier compared to the cross flow classifier is the shorter time that the input material remains in the classifier.

A modification of the counter flow air classifier is introduced by the Gipoair air classifier. It is a technological innovation which combines sieving and air classifying practices. The input material is sieved in 4 different aggregates after passing through sieves with 35 mm, 18mm and 8 mm width. The fine fractions of 8/16mm and 16/32 mm will be separated from the light material (wood, cable, Styrofoam, foil) by two fans which blow away the light fractions. This type of classifiers can produce up to 1000m³ of pure aggregate of 8/16 mm and 16/32mm. However according to the manufacturer the Gipoair air classifier will not be further evolved for the moment.

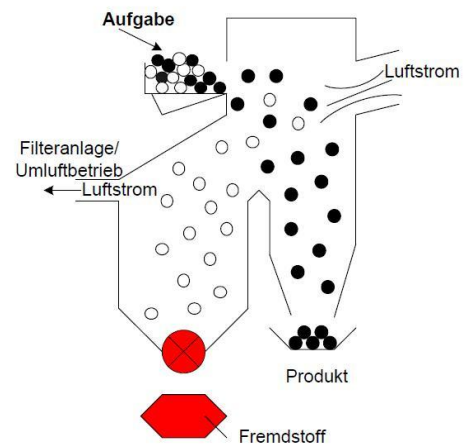

Figure 2.16. Crossflow classifier (Bilitewski 1995)

3. Zick-Zack classifier

The Zick-Zack classifier is the most common classification technique in the last 60 years and a lot of research for their evolution has taken place in recent years. Their technique is similar to the counter flow classifier technique. The mixed aggregate is inserted at the middle of the zick-zack pipe. At every junction the material flow and the counter airflow meet, as a result the heavy material slowly flows down while the light material is carried away upwards by the flow through the canal until it is extracted. The concatenation of the junctions and the height of the pipe can vary and they define the purity of the final aggregate. Moreover thanks to these properties the zick-zack classifier is appropriate for difficult separable materials.

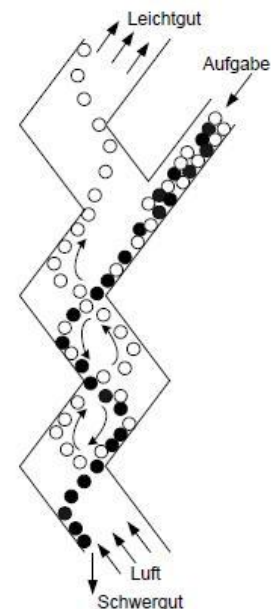

Figure 2.17. Zick-Zack classifier (Tomas 1999)

Other kind of dry classifiers

The previous classifiers were based on air stream classification. There other technologies as well to separate materials but they were not widely implemented on the demolition waste classification process, however they could have efficient results. Such classifiers are the elasticity and the grain shape classifiers.

Dry Classifiers: Elasticity classifiers

The main principle of the elasticity classifier is the plastic ability of the materials. The function of the classifier as shown in the picture works as follows: The mixed aggregate fractions fall on a collision plate. After the crush with the plate they obtain kinetic energy and they are launched on an another surface creating a different distance related to the material properties (Schultmann et al. 2003). However the disadvantage of this technique is that the strong scattering of the jump distances of the materials lowers the efficiency of the classification when compared to the air classifiers. The geometrical properties of the material and the plate have an important impact on the outcome.

An another version of the elasticity classifier is a combination of elasticity and air classification. As shown in the picture 2.19 the elasticity-air classifier is consisted of a collision plate and a rolling drum. The input material falls onto an adjustable collision plate and is driven on a specific point on the drum. The heavier material (like stones) obtain more kinetic energy while falling surmounting the centrifuge force of the drum, while the lighter material is carried away by the aforementioned force. A locking cap and an air nozzle are helping the material separation by helping the light material be carried away. The air nozzle is movable so that it can serve either the counter or the cross flow function. The various ranges can produce an output from 20-30 to 50-60 m³/h.

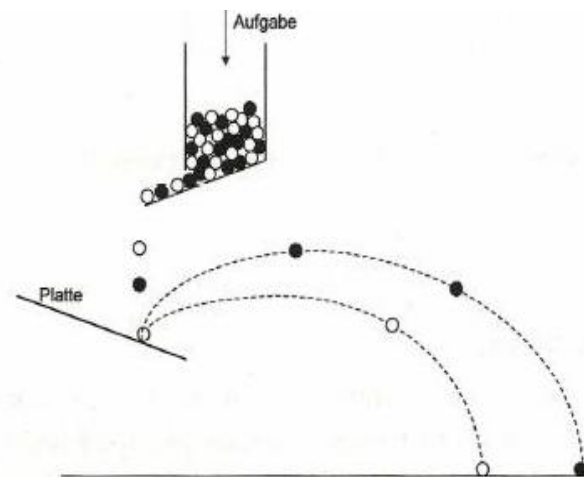

Figure 2.18. Elasticity classifier with plate (Dallmann 1999)

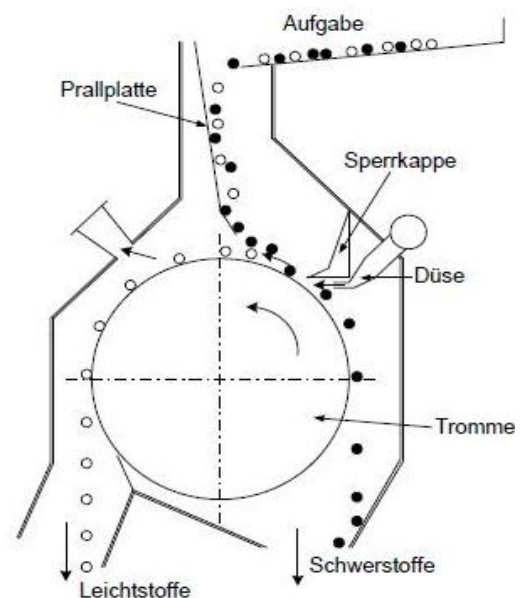

Figure 2.19. Elasticity classifier with rolling drum (Dallmann 1999)

Dry Classifier: grain form classifier

In this type of classifier the differences between the grain forms are used to separate materials. On an inclined surface round and cubic grains tend to roll while stongly different shapes stay on place or glide. A large number of classifiers separating the materials according to their shape form has been developed. Among them the most common ones are the inclined belt separator, the roll separator, the disk cleaner and the swing sorting.

Dry Classifier: Inclined belt separator

Efforts have been made in order to introduce this type of material classifier in the demolition waste treatment era. The method works as shown in the picture. On a specific point on an inclined rolling band falls the material input. Cubic and round pieces start to roll on the band following different orbits related to their mass and velocity they obtain from gravity. Platty material like glass or tiles as well as light fractions like wood and paper stay on the band and are collected at the band end. This method proved to lead in a better material quality during the pre-classification procedure. But still the mineral materials are not separated to the desired level.

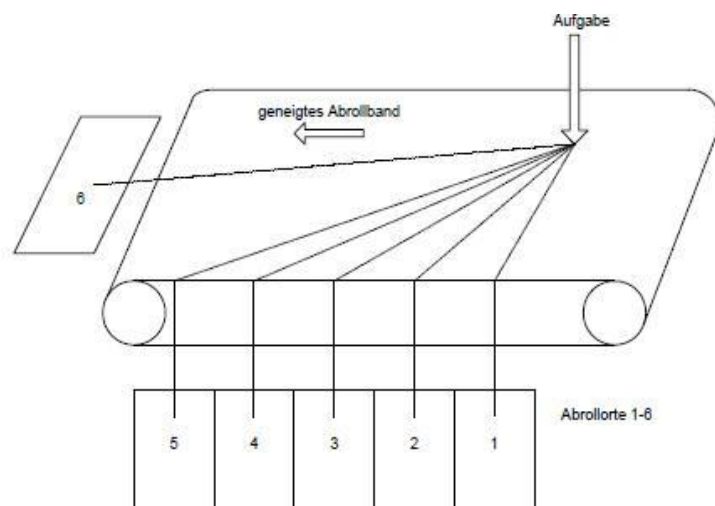

Figure 2.20. Elasticity classifier with inclined belt (Dallmann 1999)

Wet classifiers

1. Hydro band separator (Aquamator)

The modeling of a hydroband classifier can also be constructed analogous to the air separator on a balance of forces on a single grain. Separation characteristic is the sinking velocity of individual particles in the water (Raess et al. 2003). The hydroband classifier functions as follows:

The input material is inserted in the separation washing bed, launched counter to the direction of the rolling band. The separation-washing bed is formed from a corrugated edge belt and the underlying length and height adjustable support roles. The light, floating fragments are carried away by the water stream of at least 3 bar pressure, created by individually adjustable shower tubes with flat and round nozzles. The heavy material surmounts the water outflow and remains thanks to strong friction forces on the corrugated edge band. At the end destination of the heavy material a dehydration sieve is recommended. At the other end of the hydroband classifier a pulsation track leads the bigger pieces of the light material back to the water outflow so that they can be detected and eliminated.

The water of this type of wet classifier doesn't need to be clean, it can contain impurities with a maximum size of 4-5 mm. As mentioned before the water pressure is around 3 bars, while the functional power 4 to 5,5 kW.

According to their size the Hydro band classifiers demand approximately 40 to 160 m³/h water circuit. The evaporated and extracted water is renewed with fresh. The cleaning of the sewage water is process of several stages. The used water is led with pressure to a higher standing hydro cyclone. The used water is undertaken by the cleaning process while the impure fine fraction contained in it are either added to the washed grain or stored separately.

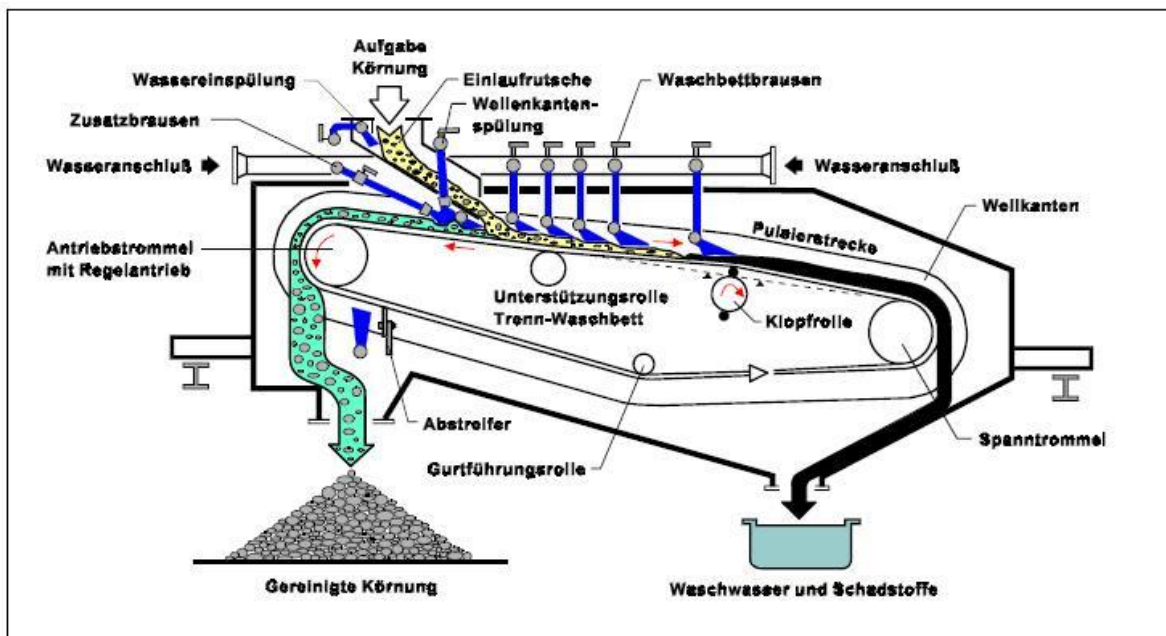

Figure 2.21. Hydroband separator (Dallmann 1999)

2. The washing drum

The washing drum is consisted of a conical washing and separating drum combined with an extraction chamber for the washed mineral material.

On the multiple level drum shell and on the front side of the extraction chamber nozzles are found which function in favor of the washing process.

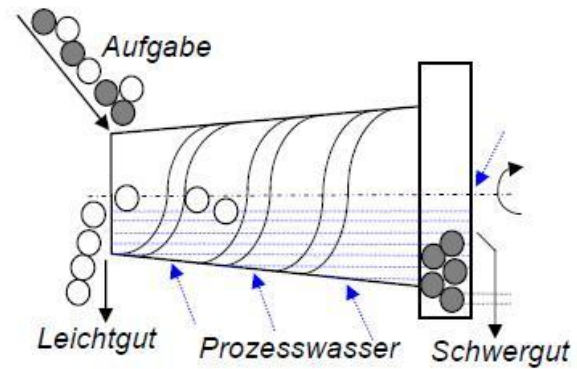

Figure 2.22. Washing drum (Dallmann 1999)

The washing drum is among the most financially convenient material classification methods because of the low energy and water supply demand. The input mix of mineral and non-mineral material is inserted through a hole in the washing drum. As the drum rotates in a turbine way the strong water flow that is created empowered by the nozzles dissolves the light impure material incorporated in the input mix. Water as separation substance is constantly inserted from the opposite side of the material input side. This opposition results in the light material being carried away by the water flow, while the heavy material falls on the inclined surrounding wall of the water drum and slips with the help of the turbine downwards, till it reaches the extraction chamber.

The mud created by the washing procedure can be either disposed or used for fine fraction depending on the initial material mix. The proportion between the material and the water supply is about 150 t/h for the material and 80-90m³/h.

DRY CLASSIFIERS		WET CLASSIFIERS	
Advantages	Disadvantages	Advantages	Disadvantages
Lower Cost	Dependence on the size of the fragments	Less dependence on the size of the fragments	Higher Cost because of water consumption
Independence from Weather Conditions	The quality of the final product depends a lot on the humidity of the input material	Production of output material whose weight is pure from non minerals	Higher Cost because of mud disposal and water recycling
No mud from washing water produced	For road construction the input material must be moistened		Extreme foam production
			Vulnerability of slurry pumps
			Clogging of nozzles
			Weather dependence

Table 2.2. Comparison between dry and wet classifiers (Rentz, Seemann, Raess, Schultmann 2003)

2.4 After the Treatment: Recycling, Incineration, Landfill

Where does the waste go after the sorting plant?

The previous pages presented the technology which enables the demolition debris to be separated into mineral (stone, brick, tiles) and non mineral material (metals and organic substances). The classified aggregate have common physical characteristics and reduced volume compared to the untreated material input. Dealing with the sorting fractions is the arising question after the sorting plant. The classified fractions are rarely pure, that means the sorted mineral fractions will always contain some small percentages of metal fragments or organic substances which denature their purity. That might affect their suitability for further processing.

For instance a fraction of fragmented concrete might contain some small quantities of toxic metals like nickel [Ni] or chrome [Cr] but in percentages which exceed their content in the earth crust. As a result this makes the concrete fraction unsuitable for landfilling without further processing. In general after the demolition, the debris has three possible destinations: recycling, incineration or landfilling. These possibilities will be described in detail below along with their disadvantages.

Recycling and Down Cycling

It is often assumed that recycling products is as energy sufficient as reusing them. This fact is rarely the case. Recycling is invariably involved with transportation and reprocessing which require extra energy consumption, while reused elements consume a very few or no energy for re-processing and the only extra energy related to reused material is transportation to the new construction site. As far as recycling is concerned not all materials have the same recycling capacity and many times recycling results in down cycling. That means that the recycled product is of a lower quality than the initial one and hence they cannot function the same way as the initial material.

Down cycling in concrete

Concrete has a high recycling rate in many countries. For instance in the Netherlands almost 90% of the concrete used in construction is recycled. However the recycled concrete aggregate is not suitable to be used again in framework. Because of its degradation it is used instead as a base in road construction or in the building structure with light or no reinforcement. According to the Dutch norms, only 20% of recycled concrete aggregate can be used for new concrete elements.

Recycling and Reuse of steel

Steel production requires great amounts of embodied energy. However a great quantity of steel is recycled. Analysis of end-of-life scenarios of steel products shows that 83% of steel components are recycled, 14% of steel products are reused, and 3% land-filled. Steel is rarely degradable because it can be fully recycled and used again in new structures. In the moment 40% of the steel used worldwide is from recycled steel, while recycled steel consumes 50% less energy than the initial steel production(Durmisevic. 2006).

Recycling and Reuse of aluminium

Aluminium similarly as the steel needs great quantities of energy to be produced. However its life cycle is long (30-50 years) and apart from its durability, it can be used again and again without downcycling.

Recycling of PVC

Usually different kind of plastics are melted down and combined to create a new recycled plastic product. However in this process the polymers (the chemical chains plastics are made of) are shorten and hence the properties of the new product are altered resulting in lower elasticity, clarity and tensile ability (Mc Donough W. & Braungart M. 2009). The recycled byproduct will have either lower performance and be used for park benches or speed stoppers in highways, or in order to regains its initial characteristics chemical additives will have to be introduced into the byproduct. As a result the downcycled plastic will have more additives than the virgin one.

Incineration

"Incineration is a waste treatment process that involves the combustion of organic substances contained in waste materials. Incineration and other high temperature waste treatment systems are described as "thermal treatment". Incineration of waste materials converts the waste into ash, flue gas, and heat. The ash is mostly formed by the inorganic constituents of the waste, and may take the form of solid lumps or particulates carried by the flue gas. The flue gases must be cleaned of gaseous and particulate pollutants before they are dispersed into the atmosphere. In some cases, the heat generated by incineration can be used to generate electric power." (wikipedia 2011)

It a usual scenario that organic compounds with high calorific value are contained in the demolition debris. After the sorting and classification procedure fraction with such compounds like wood, paper, cardboard and PVC are sent to the incinerator to be burned.

Advantages: The incineration produces electrical energy and is used the last decades in several countries as a waste treatment process. Apart for the waste-to-energy function among the advantages of the incinerators is the reduce of the waste volume about 80-85% and the effective treatment of certain toxic or pathogenic clinical waste which is completely extinguished at high temperatures.

In 2005, waste incineration supplied the population of Denmark with 4.8 % of the total electrical energy and 13.7 % of the total domestic heating. Many european countries rely heavily on incineration for handling municipal waste like France, Germany, Netherland and Luxembourg (wikipedia 2011).



Figure 2.23. The Spittelau incineration plant in Vienna, designed by Friedensreich Hundertwasser (wikipedia 2011).

Disadvantages: Some people are still concerned about the possible health problems caused by the dioxin and furan emissions into the atmosphere from old incinerators. Filter bypass is strictly required as incinerators usually emit varying levels of heavy metals like: vanadium, manganese, chromium, nickel, arsenic, mercury, lead, and cadmium, which can be toxic at very minute levels. Supporters of zero waste consider incinerators an impediment towards reuse and recycling and they are strongly opposed to the use of waste resources for energy production.

Landfill

Landfill is the most common way of dealing with material waste. Because of the population expansion and the constant extraction of raw material at the service of the construction industry landfills are the dumpers of what is thrown away regarded as useless. Among the untreated construction waste ending up in a landfill exists a 10-15% percentage of partly degradable organic material such as wood,



Figure 2.24. Landfill (wikipedia 2011)

paper and plastics, along with trace

elements of toxic substances one or two orders of magnitude above the average earth crust. Nitrogen, sulphur and chlorine are abundant in the construction wastes. Such substances are expected to yield leachates and landfill gas in the short and the long term run, denaturing the soil composition and contaminating the underground in way that it is going to need many generations to deal with the problem in the future.

A pretreatment of the waste and especially a chemical test of the waste composition before landfill is more than essential. A leaching behavior test can be assessed in many ways (P.H. Brunner & M. Stampfli 1993):

1. with chemical analysis of the waste composition
- 2 with laboratory experiments to determine the main chemical reaction of the waste with water, acid, bases and various redox substances
3. with field studies parallel to the laboratory analysis

It is not possible to set a universal leaching test as the earth's crust composition differs according to the region. The testing has to be done separately each time before landfilling.

Landfill and incineration are dealing with strong arguments against them. They both focus on getting rid of the waste, while the current environmental concern is material recovery. Reuse and recycling ensure prolonging the residence of the material in the anthroposphere and decrease the extraction of raw ones The figure below depicts the gradation between the most and the least sustainable waste treatment technique .

MATERIALS



Figure 2.25. Gradation between best and worst waste treatment with blue representing the best and red the worst (<http://www.lifecyclebuilding.org/files/DFD.pdf>)

DECONSTRUCTION AND DEMOUNTABLE STRUCTURES

3.1 DfD: Closing the building life-cycle loop

The previous chapter presented the most common waste treatment strategies with their advantages and disadvantages. However the waste management problem is more complicated than it seems and the treatment we have been implementing through landfill, recycling and incinerating during the last two decades cannot have the desirable material recovery we need today in order to reduce significantly the extraction of raw material. Before addressing the problem one needs a step back to where and when it started and realize that the waste problem is a link in the chain of ecosystems destruction.

3.1.1. Why being "less bad" is not effective anymore?

The environmental problem started becoming crucial in the 19th century with the beginning of the industrial revolution. Industries at that time were growing by transforming natural resources into products. Factories were situated in places close to natural resources and water bodies, this way they could have easy access to raw materials and dispose their waste in water.

The dominant notion at that time was that mother nature, perpetually regenerative, would absorb all things and continue to grow. At the same time, humans perceived natural forces as brute and hostile, which had to be subdued. Human force was exerted on natural systems, agriculture prevailed over prairies, pesticides were used to kill different kinds of unwanted insects and plants, and hybrids of vegetation were invented to ensure a quicker food production.

In the preindustrial times, people were consuming products, but they were safely biodegradable once thrown away, incinerated or buried. In nature there is no sense of waste, the ecosystem has its flora and fauna mechanisms to turn the excreta of one organism to the nourishment of another.

An apple tree for instance blooms and its blossoms turn into fruits. Some of the blossoms fall onto the ground but they are far more than useless, they feed the insects and enrich the soil. Humans produce carbon dioxide by expiration which is absorbed by the leaves of the trees to produce oxygen. The complex metabolic mechanisms of nature are described more extensively in the book "Cradle to Cradle" written by William Mc Donough and Michael Braungart. The authors describe the loss of equilibrium in the natural ecosystems as follows:

"This cyclical, cradle-to-cradle biological system has nourished a planet of thriving, diverse abundance for millions of years. Until very recently in the Earth's history, it was the only system, and every living thing on the planet belonged to it. Growth was good. It meant more trees, more species, greater diversity, and more complex, resilient ecosystems. Then came industry, which altered the natural equilibrium of materials on the planet. Humans took substances from the Earth's crust and concentrated, altered and synthesized them into vast quantities of material that cannot safely be returned to soil." (Mc Donough W. & Braungart M. 2009).

In general, an easy way to categorize the material flux on Earth is to divide it into two main categories: the biological and the technical mass.

The biological mass refers to all the nutrients that are useful to the biosphere, while the technical nutrients are the ones required for the industrial activity (stones, metals etc.)

Biodegradable products constitute food for the biological metabolism, while technical nutrients should be handled as closed loop technical cycles, so that they can circulate within industry. To maintain the natural equilibrium, biological nutrients should not be mixed with the technical ones because the first are lost from the biosphere and the second are downgraded. Moreover they should also not be mixed with each other in a way that their byproduct is of a lower quality than the initial one.

There are some materials though, invented by the chemical industry which do not belong neither to the biological, nor to the technical cycle. These materials are supposed to be toxic and should receive special treatment, if not completely excluded from the industry. Such materials are nuclear waste, PVC, antimony and others. These toxic material shouldn't end up in landfills or incinerators, but rather they should be stored until appropriate detoxifying techniques are developed.

Demountable structures

Keeping the technical nutrients in the technical cycle can be achieved by closing the loop between the previous and the next use of a material. More simply the best way to reduce any environmental impact is not to recycle more, but to dispose less.

Instead of trying to invent a treatment for the waste, designers should design things from the very beginning as if waste does not exist.

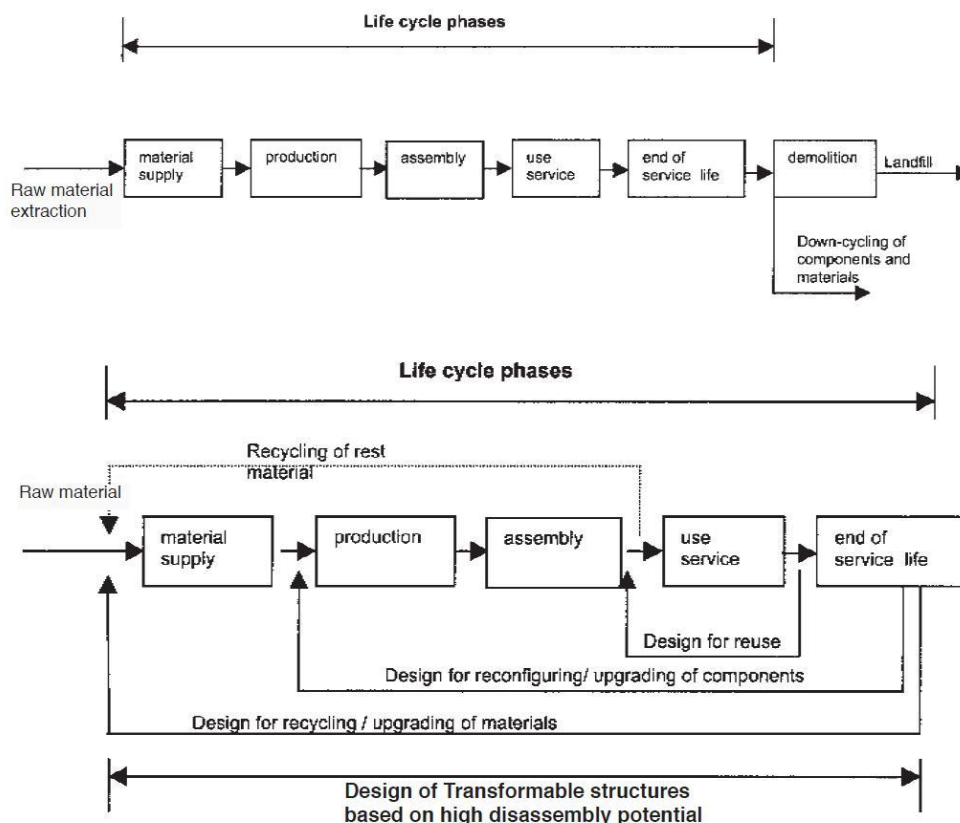

Figure 3.1. Linear building scenario and closed loop building scenario (Durmisevic 2006)

Linear building scenarios begin with extraction of raw materials and end up with demolition. All of the buildings that formed the urban environment of our cities were built according to such an end-of-life scenario.

In order to close the loop of the building life cycle and keep the construction material in the technical sphere, designers have to develop building designs which enable the material recovery. Over the last years, research is moving towards the feasibility of such a design. The current scientific literature has interesting information to provide about demountable or transformable structures, Design for Deconstruction (DfD) and Design for Recycling. One can narrow down all the sustainable building design strategies in two main directions:

- a. buildings should have an open and flexible design which enables reuse of the components and maximum material recovery in an effective time frame and at a reasonable cost.
- b. the appropriate construction materials should be chosen to preserve the equilibrium of the ecosystems.

3.1.2. Design for deconstruction (DfD)

The way building components are put together has a severe effect on whether or not a part of the building or the whole building will be recycled after the end of its life cycle. That means the way one defines the material and energy flow during the construction is responsible for the material and energy flow from the building at the demolition phase.

The linear building scenario lead to structures whose functions and materials depended on a rigid and permanent structure not allowing any alterations and disassembly. The inability for functional and technical transition within the building systems often results in significant energy consumption, waste production and lack of technical serviceability (Durmisevic 2006).

Such a static building model neglects the fact that building components and systems have different durability behaviors within time. For instance the structural frame of a building may be able to last up to 75 years or more, while the service system might need to be changed in 15 years or less. The skin of the building or some of its components (e.g. panels) are also subject to frequent change because of the aesthetics or durability reasons. The picture below depicts the most common time frame for the main building components.

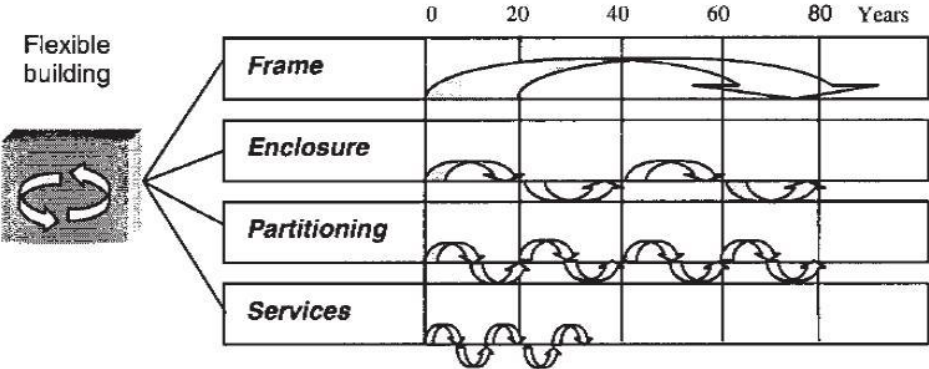

Figure 3.2. Different layers of the building structure have different life cycles (Durmisevic 2006).

To address such an open and flexible building, means that we must find and design ways to have easy access to the different layers of the building system (structural, functional, performance) in order to replace or reconfigure them whenever needed.

In order to increase the potential of a building to be disassembled, designers have to change their perception of the building's technical composition from being permanent and fixed to being changeable and open. Moreover, we want buildings to have the ability to be deconstructed in their entirety and if possible to allow material recovery by reuse or recycling. That is what Design for Deconstruction is all about.

In general issues faced with static and unsustainable construction practices:

- complex designs
- lack of foresight
- the bonding of dissimilar materials
- and the contamination of waste streams.

Leading towards an innovative design approach such as DfD, it is essential to define some design principles which support the upper goal of no waste disposal. Definitely this might seem messy at the beginning and require some experimentation and extra time until eco-effective solutions in construction will be found. But as Albert Einstein observed:

"If we are to solve the problems that plague us, our thinking must evolve beyond the level we are using when we created those problems in the first place."

On a conceptual level architects and designers should bear in mind some of the following principles:

1. Be informed and choose the best even from a limited amount of information

It is difficult if not impossible to have always access to the information when choosing a product. The truth is that there is an enormous number of products in the market and little is known about how they are produced and what substances they include (Mc Donough W. & Braungart M. 2009).

For instance, one might find himself choosing between a petrochemical-based fabric and a natural cotton one, just to find out that the cotton one was produced with petrochemically generated nitrogen fertilizers, toxic insecticides and herbicides.

But many real-life decisions come down by choosing the least harmful among the two. Being aware about sustainable design and material toxicity will lead to better choices than not having considered them at all.

2. Respect ecosystems and eco-diversity

The vitality of ecosystems depends on the diverse relationships the different species have with each other. Insects which are killed by pesticides to protect the crops, create holes in the ground, so that the air can enter the soil and make it more fertile, while simultaneously they become food for other animals. Different species contribute to the maintenance of the natural equilibrium. Different areas on Earth have their own natural equilibrium and the technical infrastructure incorporated in them. Monocultural manufacture techniques which were implemented in recent

years have removed the treads of the local ecosystems one by one, so that in the long term, ecosystems became instable and more vulnerable to natural catastrophes and disease.

If nature is our model, then probably industries which connect richly with their natural environment and local infrastructure could encourage local material and local energy flows to enter manufacture sustaining the local equilibrium at the same time. For instance, in the building construction industry, the use of local material would save energy on transportation, the application of traditional design techniques rather than international ones would integrate buildings better in their local environment, but still design for deconstruction can be an international principle for construction industries worldwide.

3. Reinvent design systems

In order to avoid waste disposal, a designer has to decide whether the material he/she is using will return to the biological or the technical sphere. Returning waste to the biological sphere is more related to landfilling, while the technical sphere with recycling and reuse. In any case, to design a product with a life-cycle loop scenario is an innovative concept which requires ingenuity activation. The examples below will give a clue about the kind of ingenuity designers should apply.

In the early 1990s the DesignTex company asked Michael Braungart (Founder of EPEA International Umweltforschung GmbH in Hamburg and former Greenpeace activist) to design with William Mc Donough, (an American architect cofounder with M.Braungart of the McDonough Braungart Design Chemistry MBDC) a compostable upholstery fabric in collaboration with the Swiss textile mill Röhner.

The fabric needed to be aesthetically competitive and environmentally intelligent (Mc Donough W. & Braungart M. 2009). The first proposal was a fabric made of cotton combined with PET (polyethylene terephthalate) fibres from recycled soda bottles. Such a product would be cheap and durable.

However after a closer test, some severe disadvantages were discovered. PET is covered with synthetic dyes and chemicals which might be harmful if inhaled or eaten. Moreover, the fabric had no recovery potential after its life cycle and couldn't return to the biological or the technical sphere. The combination would be another monstrous hybrid ending up to landfill with probably dangerous consequences.

So, the selected strategy for the fabrication of the high quality upholstery fabric was based on filtering the mutagenic, carcinogenic and toxic substances not at the end, but at the beginning of the process, so that the final product would be so harmless that it could also be nutritious.

Among 8.000 materials used from the textile industry, only thirty-eight with "positive qualities" (with less toxic additives and corrective substances) were finally chosen to produce the fabric line. Definitely the process required expensive and laborious research, but at the end solved a number of problems.

When regulators came to the factory to check the effluent, they identified no pollutants in the water so that they thought their instruments were broken. The manufacturer saved money from the taxes for pollutants. The customers could use a non-hazardous upholstery and get rid of it any time by throwing it on the ground without regret, as the fabric was designed to be easily biodegradable.

Similar strategies could be followed for other products as well. Products that stay within the technical life-cycle, should be designed in order to be demounted, reused or recycled. While the ones which are biodegradable should not contain monstrous hybrids which will cause soil contamination.

4. Make lists of materials

Materials should be classified in lists according to their hazard for human health. Products could be divided in three lists according to Michael Braungart and William Mc Donough in their book Cradle-to-Cradle.

The X list includes the obvious and direct harmful for the human health substances . Such substances according to the International Agency for Research on Cancer and Germany' s Maximum Workplace Concentration are: asbestos, benzene, vinyl chloride, antimony trioxide, chromium etc. These substances should be excluded from the manufacture if possible.

The gray list contains problematic substances which are not so urgent for a phase out. These substances are still essential for manufacture and cannot be excluded unless replaced by equivalent substitutes. For example, cadmium is highly toxic but it is used in photovoltaic technology to produce solar collectors. Until we can rethink of solar collectors' production without cadmium, we cannot exclude the substance from manufacture.

The positive list, is the list with preferable products, defined as positive because they do no harm to human health. These products have a range of characteristics in common (Mc Donough W. & Braungart M. 2009):

- they do not cause mutagenic, teratogenic effects on humans
- they are biodegradable
- they are not toxic for flora and fauna in soil and water
- they are not bioaccumulative
- they do not cause ozone-layer depletion
- all their by-products meet the same criteria.

Designers should rethink what the products are made of, not how they are used or marketed. One should reconsider the ingredients of a product, not the product itself.

E.g. If one discovers that the blue dye of a polyester fabric is toxic, it should be replaced with another safer blue dye. If a paint contains chromium, we should replace it with a paint that contains no chromium and so on.

3.2 Detailing for deconstruction

Guidelines for architects

To put the design for deconstruction into practice, the current bibliography offers a number of guidelines for architectural design.

1. Adaptability of the plan, simplicity in geometry

The golden rule to design is to anticipate change and have a building life cycle scenario. Within the building life span, a designer should predict and propose some potential alterations of the main layout according to functional changes that might occur.

Occupancy patterns change, hence an adaptable building plan can always react to the market changes. Such buildings need to be built in standardized grids and fairly simple geometries.



Figure 3.3. Flexibility of the building plan ensures longer life cycle and functional rearrangements (Morgan C., & Stevenson F. 2005).

2. Layering of service system

Different parts of the building have a different lifespan and need faster repair or replacement than others. For instance, upgrading of the heating or cooling system, renovations, refurbishment and change of the building skin generate considerable waste, because usually buildings are not designed properly to accept these renovations and several components have to be broken down. Provision for easy access to the service system could eliminate the repair waste. The layers that need to be replaced frequently should be closer to the building surface for easier access than the permanent components (Morgan C. & Stevenson F. 2005).

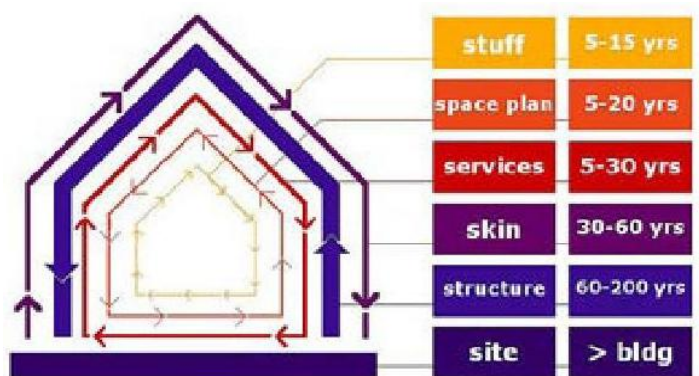

Figure 3.4. Building layers should be independent from each other and easily accessible to be removed or repaired. (Morgan C., and Stevenson F. 2005).

3.Prefer Mechanical than Glued Connections

One of the most important features to design for deconstruction is to choose the appropriate connections between the structural components. Wooden and metal frames are made of multiple components which interlock to each other. Connections are divided in three categories:

- Direct connections
- Indirect connections
- Glued or welded connections

Direct connections interlock or overlap with components, hence they are less accessible and require more time for the disassembly process, while indirect connections are independent from the components and more easily replaceable. Glued or welded connections make disassembly of components almost impossible.

In general, connections should be designed to enable independence and exchangeability of the components, for this reason interpenetration of the components and glued connections are less desirable than mechanical Connections. The table below presents an evaluation of all kinds of connection types (Morgan C. & Stevenson F. 2005).

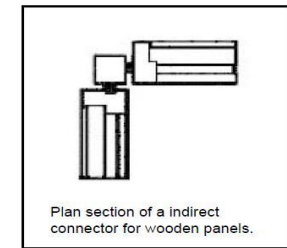
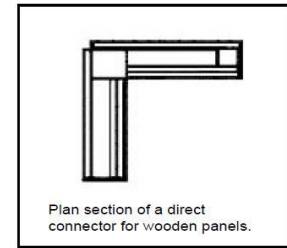

Figure 3.5. Direct and indirect connections (Morgan C. & Stevenson F. 2005).

Type of Connection	Advantages	Disadvantages
Screw fixing	-easily removable	- Limited reuse of hole and screws -cost demanding process
Bolt fixing	-strong -can be reused several times	-can seize up, making removal difficult -cost demanding process
Nail fixing	-speed of construction - cost demanding process	- difficult to remove - removal usually partly destroys the element
Friction	-keeps construction element whole during removal	-relatively undeveloped area -poor choice of fixings -structurally weaker
Mortar	-can be made to variety of strengths	-mostly cannot be reused, unless clay -strength of mix often makes separation difficult
Resin bonding	-Strong and efficient Deal with awkward joints	-virtually impossible to separate bonded layers -resin cannot be easily recycled or re-used, many are also impossible to separate.
Adhesives	-Variety of strengths available to suit the task	-adhesive cannot be easily recycled or reused, many are also impossible to separate.
Riveted fixing	-speed of construction	Different to remove without destroying the element.

Table 3.1. Connection types (Morgan C. and Stevenson F. 2005)

Masonry

The design of the mechanical joint is the key element to deconstruct a steel or wooden framed structure. Respectively the choice of mortar is the key element to set apart stones, bricks, tiles and slates in order to reuse them later on. The reuse of minerals (stones, bricks etc) is a process with a long tradition, however no standard regulations are set today to encourage and evaluate the reuse of materials.

Bricks can last for many years, more than 100 years in some cases. When buildings are broken down, bricks are mostly recycled, down cycled in specific. The recycled brick aggregates are used for road construction, sport terrains or as a substitute for sand and gravel.

Reusing them would be a much more sustainable strategy than recycling them. But it is not an easy procedure. The use of portland cement as a binding element is very common. However cement is harder than brick and trying to remove it usually ends up in breaking the brick. Portland cement could be replaced for instance by ceramic mortar. Ceramic based mortars though, also used in antiquity by Greeks and Romans, are softer and do not need to be removed. Excessive mortar dust makes the binding of recycled bricks difficult and the binding might not be stable enough. Generally the reuse of bricks has some important disadvantages:

- The reused bricks might not be all of the same quality and hence assessing the load bearing capacity of a building with reused masonry might be difficult.
- Reusing brick is a labor demanding, dusty process because the mortar can be mostly removed manually. If mechanized it is rarely successful.
- Using recovered brick might be more expensive, because of the intensive labor force it requires.

Institutes and universities are investing into research in order to further our knowledge in the sphere of clay products reuse. It was recently found out that after selective demolition, heat is used to remove mortar from bricks in order to allow re-use in housing. In cases where the mortar is a full ceramic material the separation is not necessary and re-use can later take place.

Concrete

Concrete constitutes a large proportion of the construction waste, but the majority of it is downcycled in aggregates which serve for sub-basis in road construction and infill for landscape.

Most commercial concrete buildings are in-situ constructed and destructively demolished afterwards. Although prefabricated floor slabs, columns and beams can be reclaimed, these elements usually involve tensioning which can lead to hazard during deconstruction (Morgan C. & Stevenson F. 2005). A supplementary problem is the deterioration of concrete due to carbonation, as well as the hidden deterioration of the steel reinforcement.

There are no design or structural testing standards for concrete and all we can do for the moment in order to recover concrete is to downcycle it.









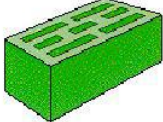

Broken Brick	Description	Quality of reused product
<p>Origin : Brick Production</p> 	<p>Brick sand crushed brick</p> 	<p>Aggregate for the production of masonry bricks, beton and light beton, stabilisation, drainage layers, fillings and embankments.</p> 
<p>Broken Brick</p> <p>Origin: Debris from building deconstruction</p> 	<p>Recycled brick sand Recycled brick aggregate (brick more than 33% with for instance beton)</p> 	<p>Aggregate for the production of masonry bricks, beton and light beton, stabilisation, drainage layers, fillings embankments and screeds</p> 
<p>Broken Brick</p> <p>Origin: Debris from building and industry construction</p> 	<p>Recycled construction origined sand Recycled construction origined fragments (brick less than 33% with for example beton)</p> 	<p>embankment for stabilisation, filling for holes in the ground and flooring for sport installations.</p> 
Mineral Waste	Description	Quality of reused product
<p>Industry debris and construction waste</p> 	<p>Mineral Construction Waste (beton, brick, nateral stone)</p> 	<p>backfilling, embankment, drainage and sport field flooring</p> 
<p>Recycling-Sand</p> <p>Industry and building construction waste.</p> 	<p>Recycling Sand</p> 	<p>embedding of energy and telecommunication line pipe, sewer, gas, water pipes and other infrastructure</p> 

Figure 3.6. Concrete and masonry crushed aggregates (Scheibengraf M. & Reisinger H. 2006).

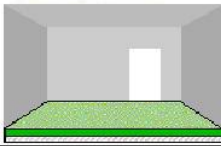
Envelop and Insulation (photos)

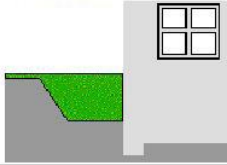
A very common problem that workers face when it comes to deconstruction or selective demolition, is the separation of the insulation from the masonry or the outer skin in general. The standards for building insulation are constantly changing, more rapidly the last years, and it would be more convenient if architects designed the insulation as a "separate layer" easily accessible and replaceable when the building envelop requires upgrading. It is essential to ensure that insulation could be replaced without damaging the structural layers and the building skin.

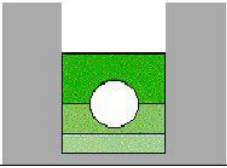
The choice of insulation is crucial for the deconstruction process. Sprayed insulation such as cellulose fiber and urea formaldehyde are difficult to salvage during deconstruction, whereas cellular blown insulation can be extracted. Even in this case a suction machine is required (Morgan C. & Stevenson F. 2005). Rigid and flexible slab insulations can be reused on a theoretical basis, however in practice rigid slabs are easily damaged compared to the flexible ones, if they do not contain much dust and detritus.

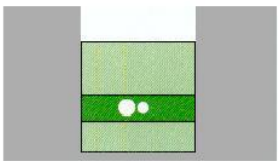
Still the best choice for insulation is biodegradable insulation like cork, sheep wool and cellulose insulation, consisting of recycled newspapers, cardboard, office paper and a number of other related products, but has high R-values.



Flexible insulation bat on the left offers greater potential for re-use.
Source: F. Stevenson



Figure 3.7. rigid and flexible insulation can be reused .(Morgan C. and Stevenson F. 2005).



Figure 3.8. cellulose insulation (wikipedia 2011)

The building skin

The building skin is the most exposed part of the building subject to weather changes, fog and air pollution. The building skin should be divided into cladding elements small in size for easy manual replacement. Grouping these elements in subassemblies enables easier deconstruction. For instance, if the cladding units are organized in groups of subassemblies, then the subassembly component can be demounted from the building with the help of a crane and panels could be disassembled on the ground to eliminate the hazard.

The replace ability of the cladding should not harm the insulation and the structural components, albeit this is not always possible given a certain construction. These wear and tear replaceable components can easily upgrade the facade's aesthetics. Internal building finishes could have similar techniques of replaceable panels, while the corners and the lower parts of the facade should have special cladding, as they are more vulnerable to decay and need frequent replacement.

Finishes and paints

Avoiding secondary finishes and coatings where possible is very important when designing for deconstruction. Finishes might contaminate the base material and make recycling more difficult if not impossible.

Such finishes are lead based paints and asbestos usually contained in several building materials and components. Hence, it is better practice to use material with their own surface as a final finishing, or finishes which can be removed from the material (protective coating such as galvanizing) is a more sustainable solution which leads to material recovery.

Lead based paints are mostly applied on wooden elements. These wooden elements should be disposed of separately and treated before reuse. The Consumer Product Safety Commission of the US started regulating the elimination of products having lead based paint finishes (EPA 2008). Instead of lead based finishes, manufacturers should use water based paints.

Asbestos based Material

Asbestos is a natural mineral with unusual qualities. A poor conductor, it insulates well against heat and electricity. Asbestos has been used in hundreds of applications and products over the past 4,500 years. The ancient Greeks wove it into oil lamp wicks, funeral shrouds and ceremonial tablecloths. During the 1800s, it insulated the hot engines, boilers and piping that powered the Industrial Revolution.

For half a century, until the 1980s, asbestos was used in office buildings, public buildings and schools. It insulated hot water heating systems, and was put into walls and ceilings as insulation against fire and sound.



Figure 3.9 Fibrous Asbestos on muscovite (wikipedia 2011)

After the revelation of the effects asbestos has on human health if inhaled (different types of cancers, mainly lung cancer) in 1980, products containing asbestos were strongly pushed aside from the market. But still when it comes to deconstruct buildings built before the 80s, caution is required. Asbestos can be found in two forms: friable and non-friable (EPA 2008). In the friable form it needs to be removed prior to the building removal, regardless of whether it is demolition or deconstruction. A licensed asbestos abatement professional must be employed as there is always the danger that asbestos will contaminate the material debris.

Non-friable asbestos components do not require removal before demolition. But they must be stored and treated separately than the rest of the debris.

To sum up:

Deconstruction design guidelines in brief:

- Have a building life cycle scenario to guide the rest of the design choices.
- Maximize functional flexibility of the plan, so that it can be remodeled during the building's life cycle.
- Use mechanical fasteners rather than sealants and adhesives
- Simplify joints and connections
- Minimize number of components
- Minimize number of fasteners
- Separate building layers or systems
- Provide easy access to piping and cabling systems, to avoid repair waste.
- Select non-toxic materials, especially in their dispersed form (e.g. lead paints)
- Avoid composite materials
- Use modular components and assemblies
- Use recycled or recovered material to your projects.
- Keep a record of the building drawings and details to facilitate future deconstruction
- Keep a list of materials used for the construction, this will be useful years after when the building is deconstructed.

3.3. General Principles towards no waste disposal

As mentioned previously, construction waste should be prevented or reduced at source as much as possible. The EU has already indicated five key principles to manage waste (Morgan C. and Stevenson F. 2005):

1. The proximity of the waste treatment installation to the deconstruction site.

Usually when a building is deconstructed the recovered material need transportation and storage which result in additional costs and energy consumption. For this reason it is essential for the cost effectiveness of the deconstruction process to deal with the waste as close as possible to the deconstruction site. The recovered material should be stored in short distance from their place of origin and by far the ideal scenario is to be directly reused for a new construction on the same site.

2. The regional self sufficiency

A key consideration is to ensure that the extraction of material is not greater than the earth can naturally assimilate. Every place though has its own natural resources, climate and building techniques adopted to the local conditions. To eliminate waste, a designer should have knowledge of the local ecology and be aware of what materials can be found in the region and which of them contaminate the regional ecosystem.

Avoiding monocultural techniques of construction and deconstruction is very important for a sustainable construction activity. Local and traditional architectural techniques already evolved in previous years should be considered and customized to the new design standards.

3. The precautionary principle

Wherever the treat of serious or irreversible damage appears, lack of sufficient scientific knowledge shouldn't be an excuse to avoid measures to prevent environmental degradation. Although this rarely happens in practice, even limited access to information can lead to better waste treatment choice than complete ignorance or indifference.

4. The polluter pays principle

Law regulations should impose taxes on manufacturers for the waste they cause. The current Landfill Tax is already a measure towards this direction but still not enough as the waste treatment problem becomes crucial.

5. The best practical environmental option

For any given set of objectives , the best practical environmental solution identifies the most beneficial waste treatment strategy taking into account multiple evaluation criteria. Finally the solution with the least environmental damage, at an acceptable cost, for a short and long term period will be chosen. The criteria relate to different social, economic and environmental factors each time.

3.4 Deconstruction Planning

Until today there are no official regulations concerning deconstruction strategies. Waste treatment is undertaken by federal institutions. Deconstruction has proved to achieve significant improvement in the quality of the resulting waste. However, there are obstacles to a successful deconstruction process which relate to three main factors:

- extra time required
- extra man power
- appropriate technical power

A deconstruction process responding successfully to the above criteria requires a corresponding deconstruction planning.

Preplanning phase:

In order to optimize resource-constrained projects the French-German Institute for Environmental Research has developed a methodology on deconstruction supported by computer software which calculate the time required to dismantle the structure and the cost of the process. According to this methodology before planning the deconstruction process (time and cost estimation, manpower required etc) a more general overview of the building's characteristics is required and is called a preplanning phase. In the preplanning phase the type of the building (residential, administrative, monumental etc) is identified, the designs and construction details when it was built are revised and expert consultancy is recommended in estimating hazardous materials and potential contamination of building elements. In the preplanning phase rough costs are estimated and the deconstruction technique is selected. The outline in page 49 depicts the preplanning concept in brief.

Building audit or deconstruction planning:

Although it is never certain what will be found when a building is taken down, carrying out a pre-deconstruction survey can reduce a great amount of the uncertainty. The building audit consists of making a list of the materials used in the building, based on documents like construction plans and history data and identifying the pollutants included.

With the available information about the building composition and the regional deconstruction framework, the deconstruction planning can be composed. A number of deconstruction scenarios are proposed and the best one is chosen. The choice of the best scenario depends on the minimum cost of the deconstruction process, the minimum human and technical resources, the minimum time required to dismantle the building partly or completely and the maximum quantity of recovered material (CIB 2005).

Here most recommended way to deconstruct a building with successive stages :

1. Depletion of interior (furniture, service system etc)
2. Demounting of products containing gypsum and asbestos
3. Fireplace removal
4. Roof removal
5. floor removal
6. Staircase and Wall demounting

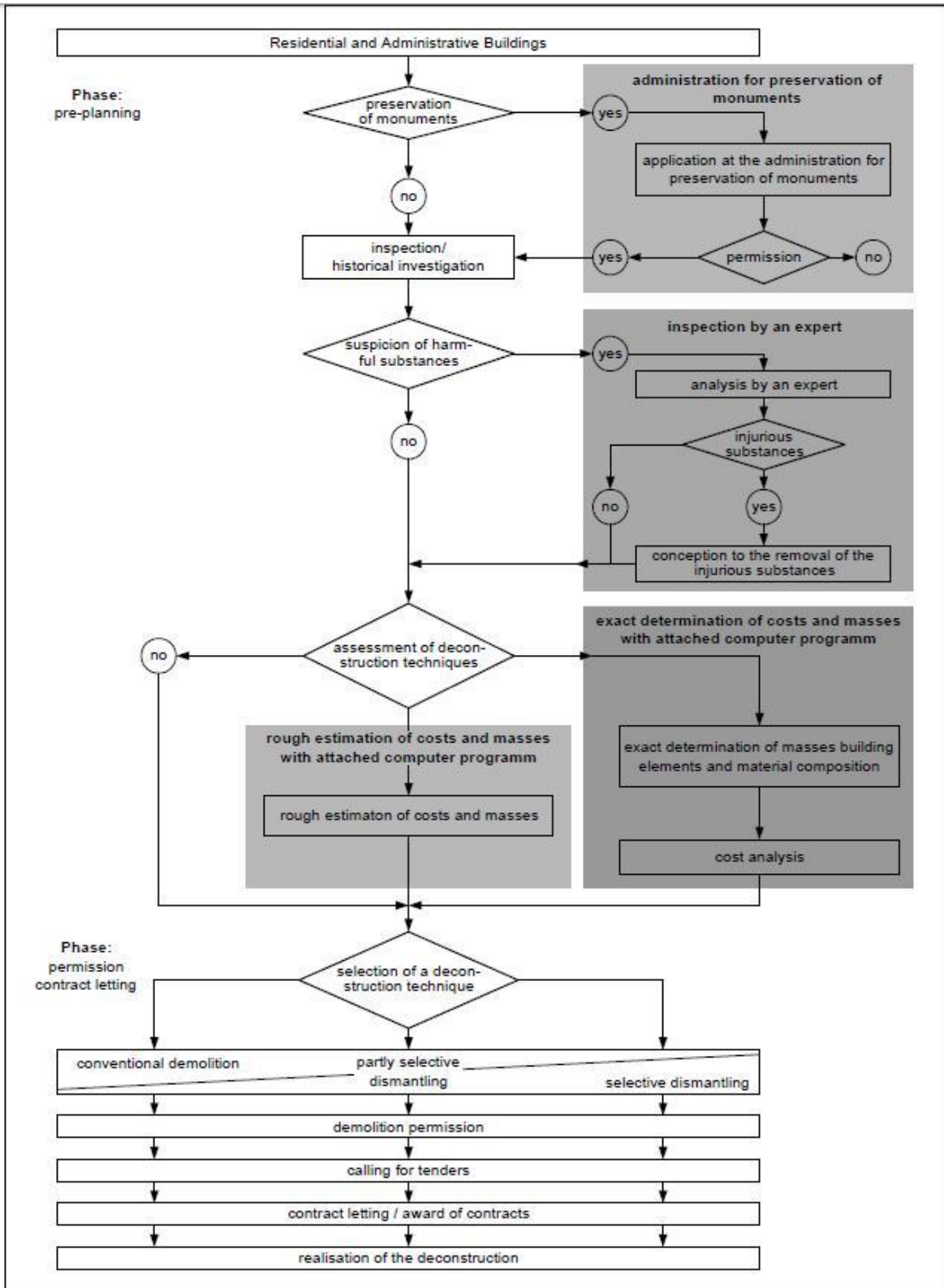

Figure 3.10. Demolition Pre-planning process (Schultmann Frank, CIB. 2005)

Deconstruction Planning example

The table below presents in the second column all the construction elements, in the third column their precise place in the building, their dimensions in columns 5-10, their quantity and the material they are made of. This way the designer obtains an analytical information list concerning the material flow expected to be extracted from the building.

Table 6 Bill of materials for a residential building (excerpt)

item no.	construction element	room no.	connected room	length [m]	width [m]	area [m ²]	height [m]	volume [m ³]	quantity	no.	building material	density [kg/m ³]	portion [%]	coating
33120	masonry (exterior)	01010	01001	4,67	2,95	10,58	0,5	5,29	12375	1	1140 sandstone	2500	80	
											2110 lime mortar	1700	20	
33410	door (exterior)	00070	00001	0,85	2,10	1,79	0,03	0,04	36	1	5100 cast iron	7800	8	
											6300 spruce	600	92	paint
33411	door-frame	00070	00001	6,00	0,35	2,1	0,02	0,04	20	1	5100 cast iron	7800	2	
											6300 spruce	600	98	paint
33430	window	01090	01002	0,60	1,22	0,73	0,05	0,04	83	2	4100 sheet glas	2500	80	
											5100 cast iron	7800	2	
											6300 spruce	600	18	paint
33440	window-ledge	01080	01002	2,20	0,20	0,44	0,15	0,07	165	1	1140 sandstone	2500	100	
33450	window-frame	01090	01002	3,60	0,20	0,72	0,2	0,14	360	1	1140 sandstone	2500	100	paint
33510	plaster (exterior)	02080	02002	2,89	3,20	5,45	0,02	0,11	185	1	2110 lime mortar	1700	100	paint
34120	masonry (interior)	02020	02090	4,90	3,20	15,68	0,08	1,18	1682	0,5	3300 solid brick	1400	90	
											2110 lime mortar	1700	10	
			02090	4,90	3,20	15,68	0,08	1,18	1682	0,5	3300 solid brick	1400	90	
											2110 lime mortar	1700	10	
			total:					0,15	2,36	3364	1			
34410	door (interior)	00140	00150	0,86	1,98	1,70	0,01	0,017	16	0,5	5100 cast iron	7800	5	
											6300 spruce	600	95	paint
			00150	0,86	1,98	1,70	0,01	0,017	16	0,5	5100 cast iron	7800	5	
											6300 spruce	600	95	paint
			total:					0,02	0,034	33	1			
34510	plaster (interior)	01010	01020	3,60	2,65	7,86	0,02	0,16	189	1	2210 gypsum mortar	1200	100	adhesive
35110	ceiling	00010		11,14	2,86	31,86	0,15	4,78	6834	1	2110 lime mortar	1700	10	
											3300 solid brick	1400	90	
35112	ceiling filling material	02050		4,97	3,71	18,44	0,22	4,06	1988	1	1530 expanded clay	600	35	
											1610 slag	700	30	paint
											6830 thatch	200	35	
35210	floor covering	03100		3,60	1,20	4,32	0	0,02	26	1	7100 plastic	1500	100	adhesive
36300	roof covering	03010		0,40	0,25	0,1	0,02	0,0015	3	280	3600 roofing tile	1700	100	
36370	downspout			9,00	0,20	1,8	0,01	0,01	15	2	5600 zinc	7200	100	
41242	W.C.	01060							21	1	3900 porcelain	1100	100	

Table 3.2. Bill of materials for residential building (Schultmann Frank, CIB. 2005)

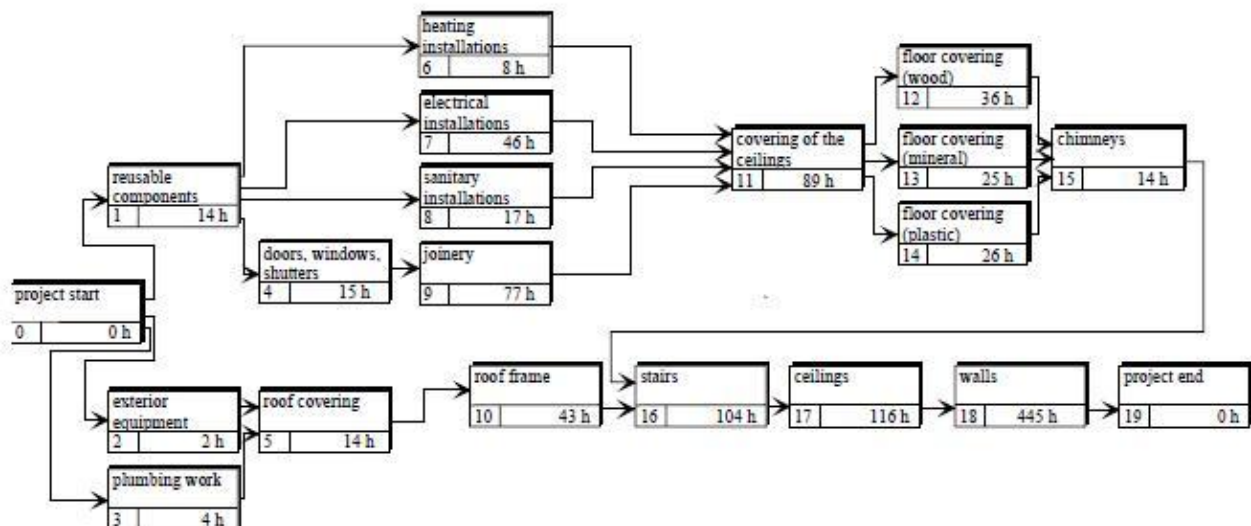

Figure 3.11. Deconstruction duration schedule (Schultmann Frank, CIB. 2005)

The data from the material list can be later used as input data in a building deconstruction simulation software, where dismantling activity alternatives can be chosen.

Temporal Planning

Temporal dismantling planning no. of dismantling scenario: 0 no. of building: 1

primary key: 408 click at a criterion and then "search" button

no. of construction element: 33120 no. of room: 02060 connected to room: 02003 search

construction element: masonry (exterior)

length: 2.8 quantity (consolidated): 1
width: 2.95
height (consolidated): 0.15 area: 6.74
volume [m³]: 1.011
volume [kg]/piece: 1445.7

composition of construction element

building material	proton (%)	no. of coating
solid brick	90	
lime mortar	10	

transfer data (dismantling and recycling data can be transferred to all construction elements with the same no.)

recycling:
recycle:
reuse:
dispose:

date	reference number: duration [h/unit]	total duration for dismantling [h]			portion
	1.32	1.32			100 (in %)
unit	duration (h/unit)	element	unit	device	dismantling technique
	1.903	masonry (not at ground level)	m²	pneumatic hammer	separation
	0.654	masonry (not at ground level)	m²	pneumatic hammer	separation
	1.32	masonry (not at ground level)	m²	mini-excavator	pushing
	0.454	masonry (not at ground level)	m²	mini-excavator	pushing
	0.364	masonry (at ground level)	m²	backhoe	pushing
	0.125	masonry (at ground level)	m²	backhoe	pushing

Figure 3.12. Demolition Optimization Software input data 1 (Schultmann Frank, CIB. 2005)

Dismantling activities

Configuration of dismantling activities no. of building: 11 no. of dismantling scenario: 1

dismantling activity: 12000 primary key: 403 sanitary installations show all dismantling activities of this building

construction elements to be dismantled			resources			
room no. (xxxx)	floor no. (x)	entire building (00000)	resource no.	resource	capacity	unit
41120		00000	7	cutter	16.60	h
41200		00000	27	container for metal	0.03	quantity 43.0 kg
41220		00000	28	container for electrical devices	0.17	quantity 15.0 kg
41230		00000	29	container for plastic	0.11	quantity 9.8 kg
41240		00000	31	container for minerals	0.01	quantity 159.2 kg
41241		00000	35	container for reusable metals	1.30	quantity 1,171.6 kg
41242		00000				
41243		00000				
41244		00000				
41245		00000				

previous dismantling activity next dismantling activity delete dismantling activity search dismantling activity close

Figure 3.13. Demolition Optimization Software input data 2 (Schultmann Frank, CIB. 2005)

Optimization of the building deconstruction scenarios can be further achieved by taking into account the following guidelines:

- To dismantle a building more quickly and efficiently parallel work on different layers is required to the maximum.
- Manual techniques with partly automated devices are more effective than total automated machinery, because of material damage is strongly avoided.
- Always dismantle a building aiming to the optimal recycling possibility, as this occurs from a material flow analysis.

The French-German Institute for Environmental Research which developed a methodology for deconstruction and recycling is also using a computer software which enables cost saving calculations for a different building model each time (figure 3.14). In this computer simulation program optimized dismantling alternatives can save up to 50% of the deconstruction cost, while in some cases the time required for the process can be reduced by a factor of 2 and a recycling rate can reach a percentage of 97% as shown below. .

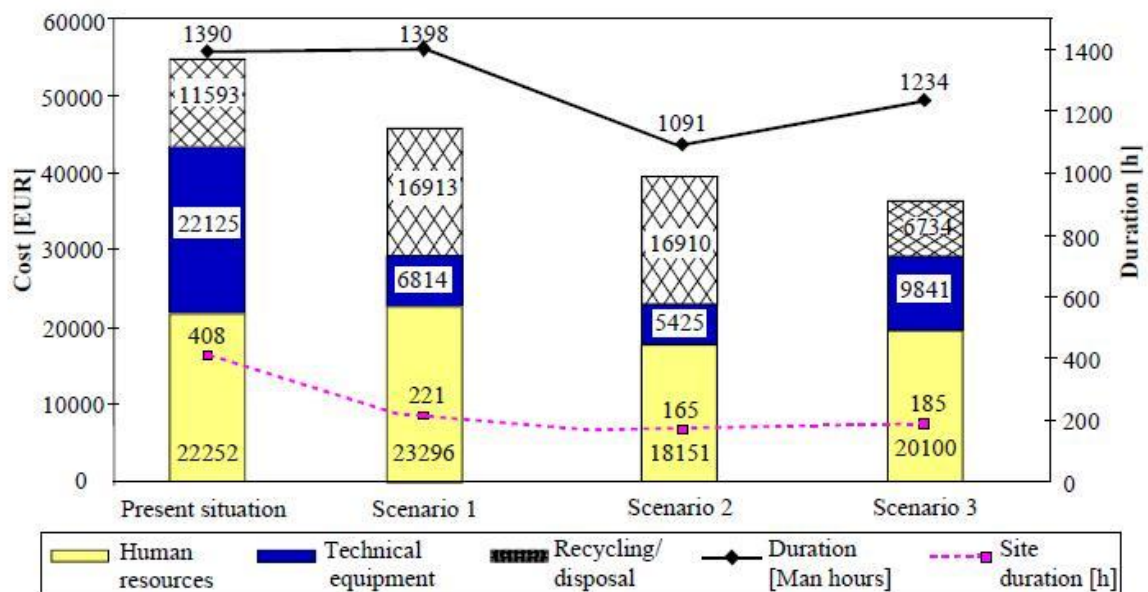

Figure 3.14. Demolition Optimization Software Result Analysis (Schultmann Frank, CIB. 2005)

3.5 Waste Management a European Overview

The total amount of CDW (Construction and Demolition Waste) in Europe is about 450 million tonnes. If one excludes earth and excavated road materials from this amount, the "core" waste is about 180 million tons per year, which means 480 kg per person. This is by no means a very high amount of dumped material.

The different member states have various recycling rates. Some countries like Ireland, Greece, Portugal and Spain recycle less than 5% of their CDW, while others like Belgium, Denmark and the Netherlands recycle more than 90%. CDW has a high recovery potential, however a small amount of 50 million tonnes approximately is reused or recycled, while the rest 130 million tonnes are landfilled or incinerated in the EU as a whole.

Member State	Core CDW Million tonnes	Re-use or recycle Percentage
Germany	59	17
UK	30	45
France	24	50
Italy	20	9
Spain	13	<5
The Netherlands	11	90
Belgium	7	87
Austria	5	41
Portugal	3	<5
Denmark	3	81
Greece	2	<5
Sweden	2	21
Finland	1	45
Ireland	1	<5
Luxembourg	0	
EU 15	180	28

Table 3.3. Hazardous Construction Waste and reused percentages (CIB 2005)

On the other hand, northern countries with strong industrial activity and relatively high recycling rates produce hazardous waste which should be taken into account in a European evaluation of effective waste management. Finland, Estonia, Luxembourg and Bulgaria have the highest rates in hazardous waste in Europe. The map in page 54 is based on a Eurostat survey, depicting the hazardous waste production per capita in Europe.

The efficiency of recovery and reuse of CDW varies among EU nations based on the following factors:

- the natural resources of each country
- the transport network and distances
- the population densities

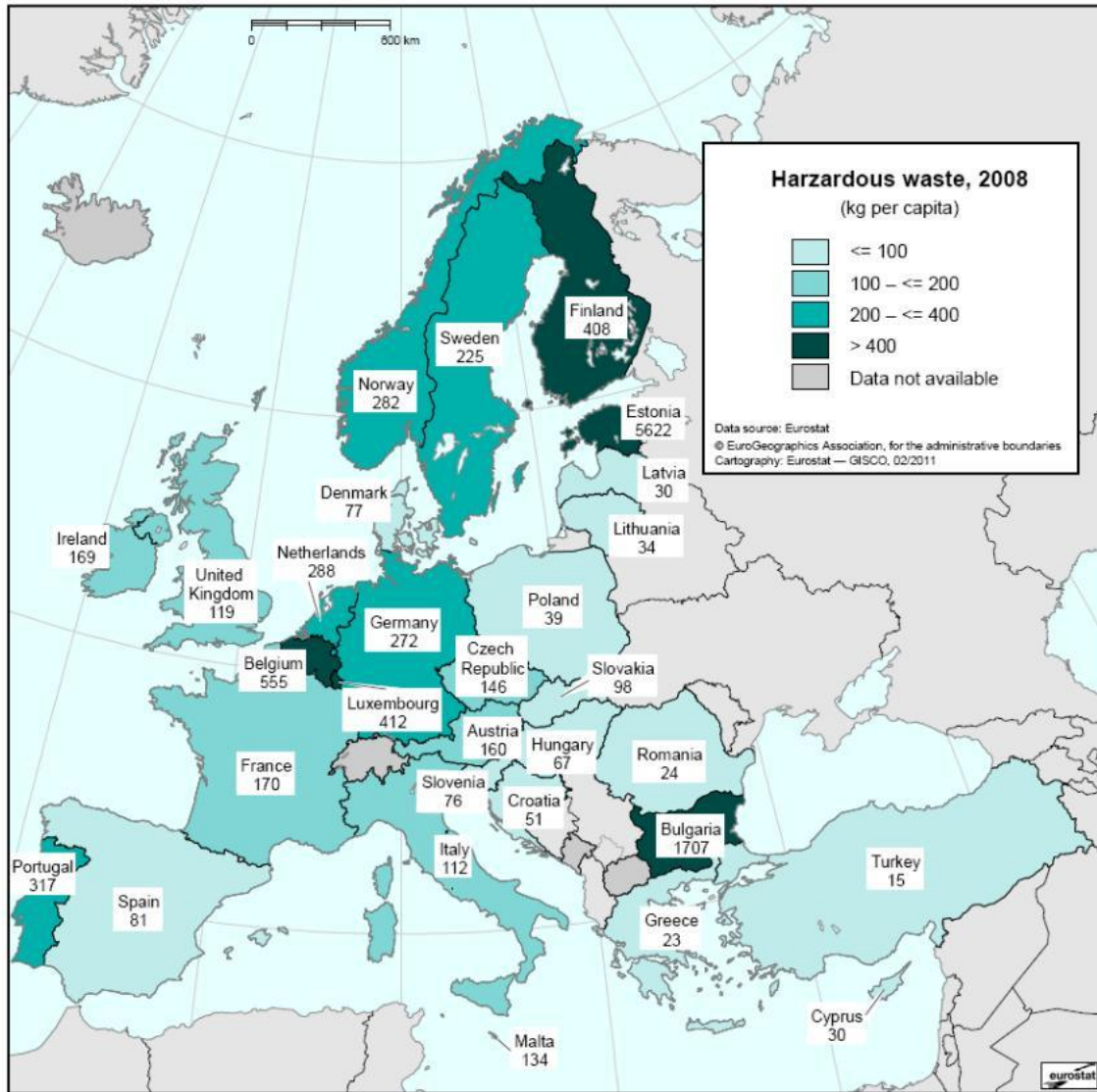

Figure 3.15. Hazardous Waste European Overview (DEFRA 2011)

3.5.1. Demolition Contracts

If a building is to be demolished, the highest possible level of recovered material must be achieved. A demolition or deconstruction planning is relevant for that process, but such a plan costs time and money. In general, a demolition contract's cost results as follows (CIB 2005):

CONTRACT AMOUNT = COST OF DEMOLITION + LANDFILL COSTS - REVENUES

If the revenues of the recovered material are high then this fact might offset the supplementary cost of the deconstruction planning. A market of "secondary raw materials" should be supported within Europe and standards for the product quality and price should be set.

The Official Journal of European Union published on 19 November 2008 offers a number of Directives about waste treatment, but includes no standards for the moment.

At present, demolition contractors in most European countries assess some very specific factors in order to proceed with demolition:

- location
- type of building
- construction method
- materials used
- hazardous material

The Demolition Process starts with an investigation of hazardous substances (ex. asbestos) which have to be removed first for the safety of the workforce and to avoid contamination of the rest of the material. If such substances exist a special contractor is required. Asbestos requires strict safety measures.

After removal of hazardous substances, the building has to be stripped of components which can be reused as they are like: marble fireplaces, radiators, leaded glass, precious wood like walnut and oak etc. DfD aims to turn as much as possible components into reusable at their initial form. Such components are usually sold directly after their removal to provide the contractor with revenues.

Selective demolition is not new in the industry. In 70's and 80's demolition was taking place with no material recovery. The capacity of machines progressed to demolishing buildings very quickly and the waste was disposed, while it was taken for granted that natural resources would last forever.

As many European countries seem to have taken little or no action concerning demolition waste treatment, this chapter will present briefly the most recent information about waste treatment as it comes from countries with remarkable activity in reuse and recycling. Usually countries with intense industrial production produce a lot of waste and hence they are more concerned about finding ways to deal with it in the most cost effective but also sustainable way. Such countries are: the Netherlands, Norway, UK and Germany. Turkey, although not a member of the EU has some very interesting insights to show in terms of material reuse and recovery.

3.5.2. Recycling Standards stated by the European Parliament

In June 2008 the European Parliament and the Council of the European Union has established a set of standards for recycling municipal and deconstruction waste. Article 11 of the EU Waste Framework Directive (2008/98/EC) states those recycling targets as follows:

" In order to comply with the objectives of this Directive, and to move towards a European recycling society with a high level of resource efficiency, Member States shall take the necessary measure designed to achieve the following targets:

(a) by 2020, the preparing for re-use and recycling of waste material, such as at least paper, metal, plastic and glass from households and possibly from other origins as far as these waste streams are similar to waste from households, shall be increased to a minimum of overall 50% by weight.

(b) by 2020 the preparing for reuse, recycling and other material recovery , including backfilling operations using waste to substitute other materials, of non-hazardous construction and demolition waste including occurring material defined in category 170504 in the European Waste Catalogue (EWC) shall be increased to a minimum of 70% by weight. "

About 850 million tones of construction and demolition waste, which is about 30% of the total waste generation, is produced annually in the EU. In paragraph 5 article 11 of the same EU Directive it is stated:

" Every three years, in accordance with Article 37, Member States shall report to the Commission on their record with regard to meeting the targets. If targets are not met, this report shall include the reasons for failure and the actions the Member State intends to take to meet those targets. "

Until today many European countries keep no or little information on their record about waste management strategies. The table below shows the C&D Waste per capita as it was published in the ETC/SCP working paper 2/2009. Only 18 of 28 European countries could offer data for such a survey so that results of the progress in this area could be gathered.

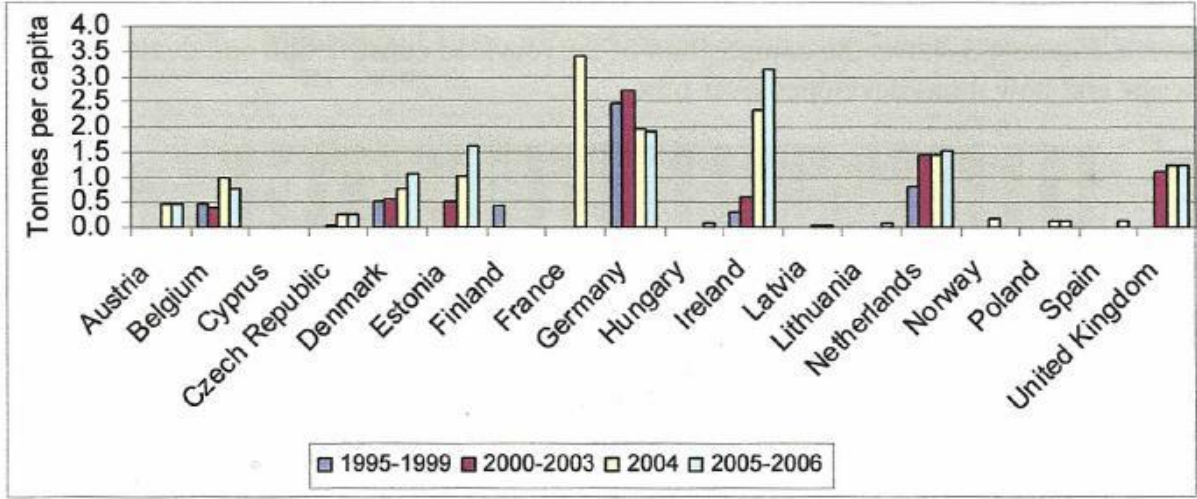

Figure 3.16. Recycling of construction and demolition waste per capita in the EU and Norway. (Fischer, C., Werge, M.,2009).

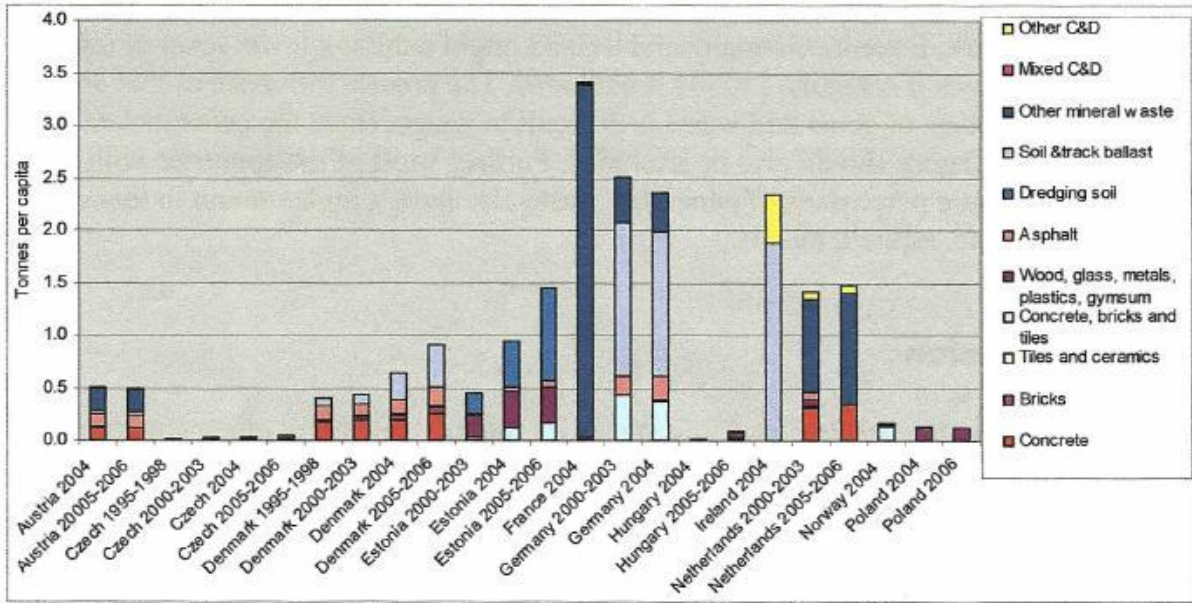

Figure 3.17. Composition in tones of recycled construction and demolition waste in the EU and Norway. (Fischer, C., Werge, M., 2009)

3.5.3. A short overview of countries with the most comprehensive documentation.

Deconstruction in Germany

About 45 million tons of C&D waste are generated in Germany, while the number of landfills is over than 1.600 (CIB2005). Meanwhile, there are 650 companies which recycle construction materials. Recycling of construction materials is not a new method for Germany, as well as for other countries. In Germany there is a long tradition in the use of recycled materials, however nowadays these recycled products are mainly used for low-grade applications because of the heterogeneity of the composition and the contamination of the demolition waste.

In Germany reusing as many building elements as possible is already in practiced thanks to the costs of recycling which do not exceed the demolition costs. Simultaneous efforts are being made to develop more effective methods of deconstruction, by implementing dismantling of buildings, manual sorting, and the use of automated separation devices.



Figure 3.18. Muhlhouse project (CIB. 2005)

Case Study: In recent years, several case studies were carried out in Germany and France. Documentation of these practices contribute to comparing the strategies and the optimizing dismantling processes. A characteristic example is a case study in Mulhouse comparing conventional demolition (with a backhoe) and deconstruction by dismantling. The factors taken into consideration to evaluate the effectiveness of the two different deconstruction techniques were:

- the duration of the demounting process
- the demounting costs
- the recycling costs for mixed and sorted demolition materials.

Dismantling can prove to be a cost efficient practice depending on the building type, the recycling options and the prices charged for the recycled materials. Significant variations of dismantling and recycling costs can be caused by different building types, disposal fees and transportation distances.

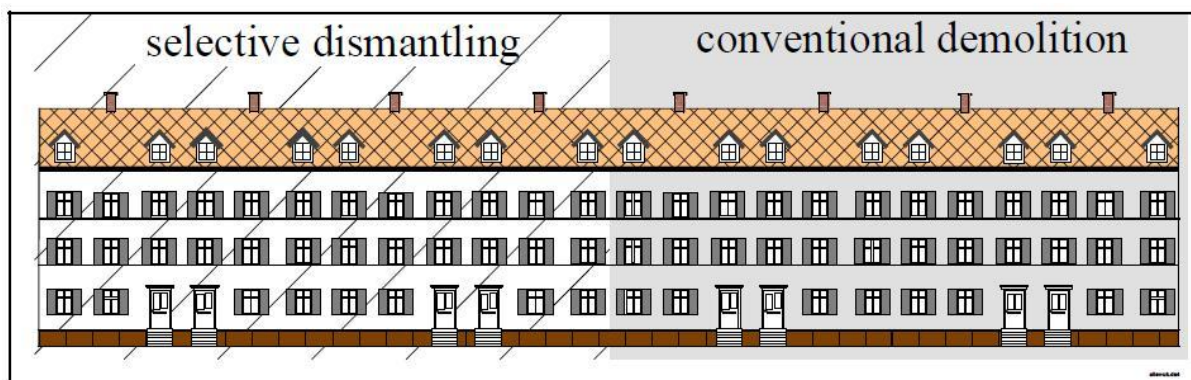

Figure 3.19. Comparison between conventional and selective demolition in Mulhouse (CIB. 2005)

Deconstruction in Netherlands

The Netherlands has achieved much success in its deconstruction efforts (CIB 2005). The Netherlands is highly sensitized and effectively active towards deconstruction and material reuse. In 1990, the Dutch government obliged construction industries by law to reuse at least 90% of the construction and demolition waste. In 2003, a percentage of 95% of C&D waste was reused in lower graded applications mostly e.g. in road base construction.

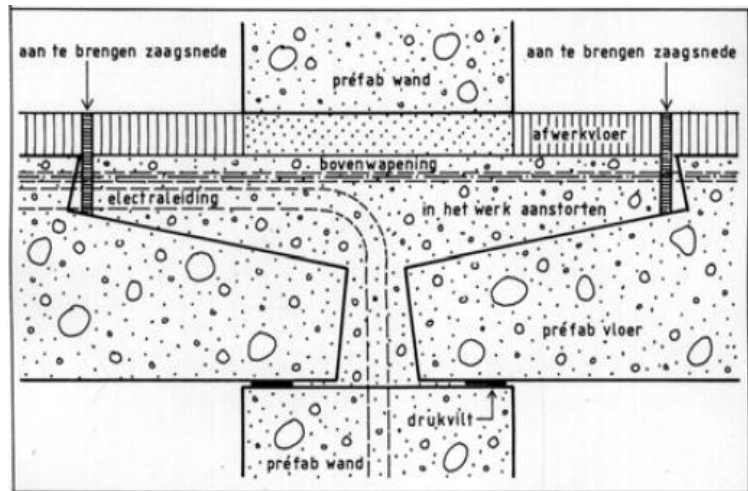

Figure 3.20. Delta BMB system bolted or steel-strip connections between concrete elements (CIB 2005).

Most demolition practices nowadays in the Netherlands take place by blasting and sites are screened to protect the surrounding area from the arising dust. Dismantling buildings to reuse their components or recycle them has become a popular practice, and so has Design for Deconstruction. Training programs for the workforce are also very popular in the Netherlands, and workers' safety is very important. Netherlands generate 21 million tons per year with the annual rate increasing by 2 million tons.

Case study: Middelburg, one of the most important deconstruction efforts was the Middelburg apartment complex. The apartment block consisted of 11 floors and was built in 1971. However, 15 years later, in 1986, there were many social problems associated with the building complex like prostitution, vandalism, drugs etc. Year by year residents were leaving the building, until only 19% of it was occupied. The building could not be rehabilitated. After a few years of design research the most feasible solution was found. The first three buildings would be dismantled, seven of the eleven floors would be removed and their components would be reused to construct apartment blocks of three and four floors. The remaining four floors would be renovated.

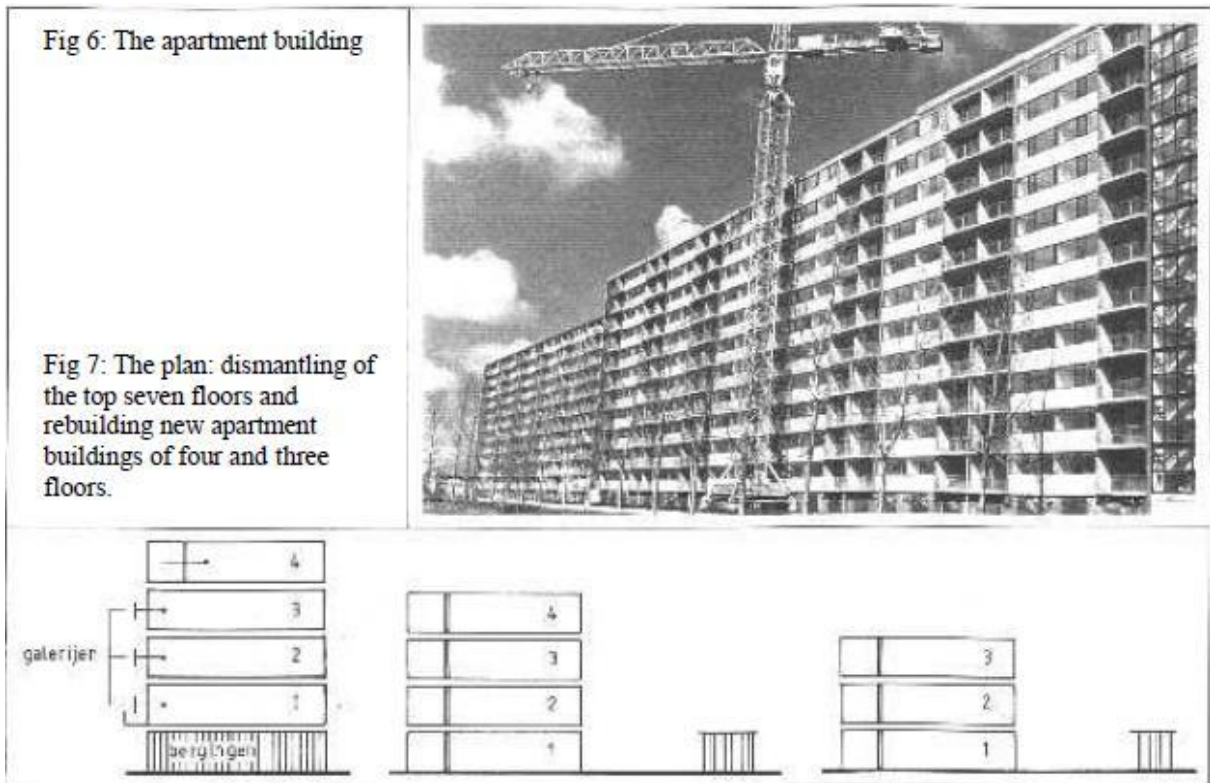

Figure 3.21. Middelburg apartment complex. (CIB 2005).

The dismantling of the building was successful thanks to the Delta BMB system, that was constructed with. The Delta BMB system is depicted in picture 3.21. The name BMB relates to the mounting method Simplified Brick Construction. The connections between concrete components are bolted or steel-strip connections. The construction of a building constructed with the dry-mounting connections contributed to the final dismantling. The walls were lifted, so that the grouted connections between walls and floors could be detached after two saw cuts made by a sawing machine. Afterwards a pneumatic hammer could easily break the grout and the floor components were disconnected from their support by an hydraulic jackscrew.

Deconstruction in the UK

The United Kingdom has also undergone some changes in the demolition sector in recent years. The poorly regulated labor intensive industry is substituted by special machinery and technology to deal with the waste (CIB 2005).

Figure 1 Total UK waste generation, by sector, 2004 to 2008

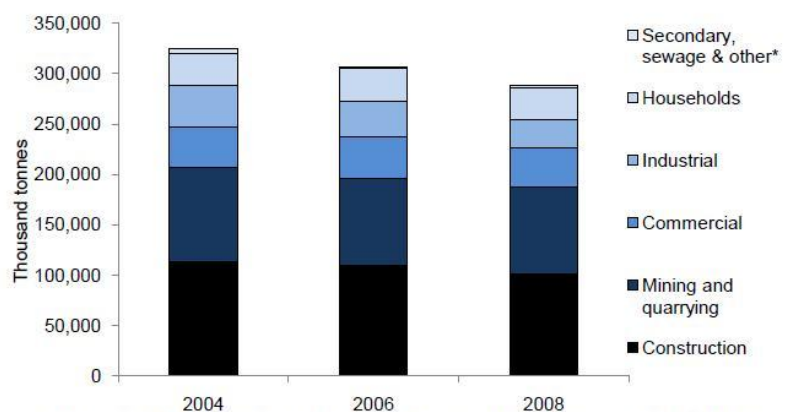

Figure 3.22. Waste generation in the UK (DEFRA 2011)

The largest contributing sector in the generation of waste is construction and demolition. In 2008 the generated C&D waste was estimated to be 101 million tones, followed by mining and quarrying with 86 million tons, commercial and industrial sectors 67.3 million tons, household waste 31.5 million tons and the remaining secondary waste 2.7 million tons.

Figure 5 Construction & demolition waste management, England, 1999 to 2008

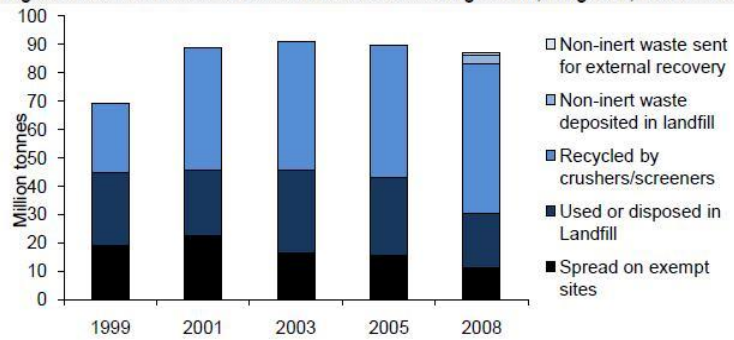

Figure 3.23. Construction and demolition waste generation in the UK (Defra-2011)

From 2004 to 2008 the demolition waste was reduced from 113 million tons in 2004 to 109.5 million tons in 2006 to 101 in 2008. The amount of the waste which is recycled has been augmented from approximately 50% in 2001 to 65% in 2008. Actually, about 33 million tons of architectural and ornamental components are salvaged for reuse per year.

Since 1999 an institution named Work Group on Sustainable Construction was established in the UK, as one of the 14 main actions to improve the effectiveness and competitiveness of the British construction industry. The C&D Waste task group working for this institution focused on the improvement of C&D waste management by deconstruction planning and material recovery practices. The most important conclusion the task group presented was that “the optimal separation of CDW must take place to maximize recovery of material for reuse and recycling.”

Concrete contributes dominantly to C&D Waste and a little amount of it is reused or reclaimed. Most commercial concrete buildings are built with reinforced concrete shell that must be demolished. However some concrete building components such as prefabricated beams and masonry blocks could be easily dismantled and reused. Steel on the other hand can be completely recycled and reused, and this is a positive fact when taken into consideration that 50% of multistory buildings in the UK are made of steel. As far as wooden structures are concerned demounting or deliberate collapse demolition are the most suitable practices.

Deconstruction in Turkey

Turkey, although a non European country, has some interesting insights concerning waste management (CIB 2005). Conventional buildings are constructed with reinforced concrete, brick or masonry walls which are plastered and painted. Ceramic tiles are used as floor finishes and doors are wooden. The wiring and piping system is embedded in the walls.

Sledgehammers and pickaxes are used for demolition, in some cases pneumatic drills and excavating machines can also be effective.

Despite the fact that Turkey is a developing country, its industrial waste equates the waste of developed countries, according to Turkey's "National Report on Sustainable Development 2002." About 13 million tons of industrial waste are produced in Turkey each year and 57% of it is disposed. Of that disposed waste 70% ends up in municipal dump yards and 30% percent is disposed of in an unregulated manner. Construction and demolition waste is not calculated in these industrial waste statistics. The environmental impact of the generated construction waste is already obvious in Turkey in recent years, especially after the earthquake in 1999 in the Marmara region the generated waste led to serious consideration about its treatment. The state realized that measures towards recycling should be taken.

However, Turkey has a thriving market for used building materials. Reusing local materials is a tradition in Turkey. Local outlets selling second hand windows, lavatories, roofing tiles etc. can be found in large cities of Turkey like Ankara, Izmir, Istanbul. Material recovery is only manual, because the quality of salvaged material is better and because no automated technology is available for such a process in Turkey. The used building materials are bought mainly by squatters, because clients who can afford professional design services and employ architects usually want to use new materials only. The picture below depicts an outlet reused building components on display.



Figure 3.24. Second hand windows, tiles and sanitary equipment sold at the local market in Turkey (CIB 2005).

Deconstruction in Austria

The way deconstruction waste is treated in Austria is specified by the Federal Waste Management Plan. (Bundes-Abfallwirtschaftsplan 2011).

The construction waste results from building construction, road and bridge construction. The building demolition debris consists 70-90% of concrete, brick and masonry fragments. The rest is Wood, Metals and other material. The construction waste represents about 13% of the total waste generated in Austria as shown in the pictures below.

The deconstruction waste in 2009 reached the amount of 6,9 million tons (Bundes-Abfallwirtschaftsplan 2011). The generation of waste is always dependent on construction activity each year, which is a variable factor. The dominant part of the demolition debris will be reused or recycled. In 2009, 5,5 out of 6,9 million tons were treated in the treatment installations, which is almost 80% of the total construction waste, a percentage higher than the goal of 70% of material recycling set by the EU Waste Framework Directive. A smaller proportion of non recyclable non homogeneous waste ends up in landfill. In 2009, the amount of landfill material was about 510.000 tons.

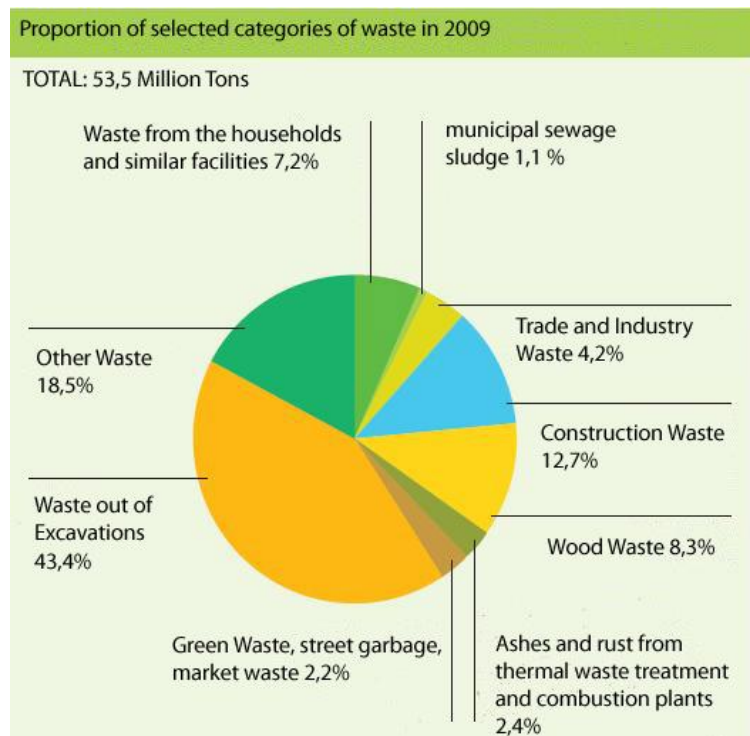

Figure 3.25. Distribution of waste in Austria into several categories (source Abfallwirtschaftsplan 2011).



Figure 3.26. Proportion of construction waste landfilled, treated or stored (Abfallwirtschaftsplan 2011).



Figure 3.27. Composition of Construction waste in Austria (Abfallwirtschaftsplan 2011).



Figure 3.28. Treatment of Construction waste in Austria (Abfallwirtschaftsplan 2011).

Asbestos and Dangerous Substances

Asbestos is a natural fibrous mineral, which from 1960 until 1980 was often used as a building material thanks to its heat and fire resistance properties. For its insulating capacity it was applied in floor insulation, but also was used as a storage medium in electrical storage heaters as well as in many other applications. However, since 1978 research proved the harmful consequences of asbestos fibers on human health and in the 90's asbestos was banned from the construction industry. The asbestos fibers when inhaled in large amounts can cause breast, lung or stomach cancer.

Since January 2004 according to the §2 of the Chemical Prohibition Order it is prohibited:

- The marketing and use of asbestos
- The manufacture and preparation of finished goods with intentionally added asbestos fibers .

- The marketing and use of used asbestos -containing materials, preparations and finished goods.

The waste containing Asbestos has significantly increased since the year 2004. This could be explained by taking into consideration that the buildings containing asbestos were raised from 1960 to 1990 and after the year 2000 they are broken down ending up to hazardous waste.

The picture below shows the storage of Asbestos cement and Asbestos cement dust as hazardous waste from 1999 to 2009. The high values in the year 2006 are caused from a high amount of imports in asbestos waste.

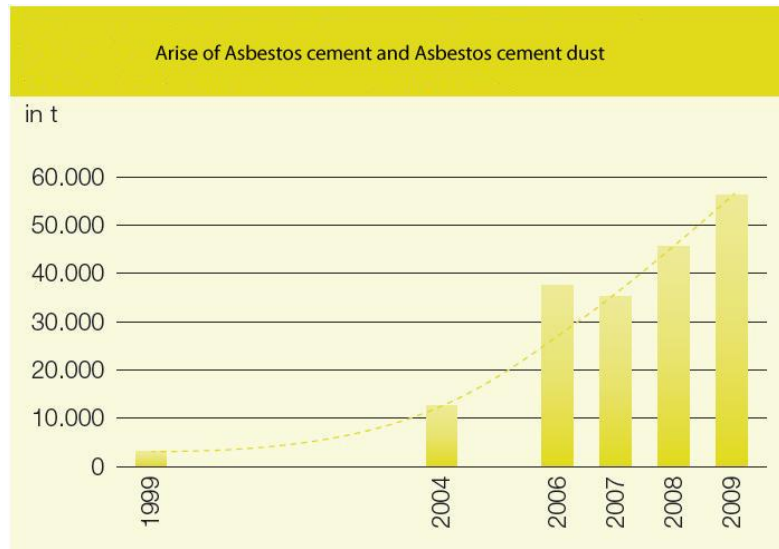

Figure 3.29. Arise of Asbestos and Asbestos cement dust in Austria (Abfallwirtschaftsplan 2011).

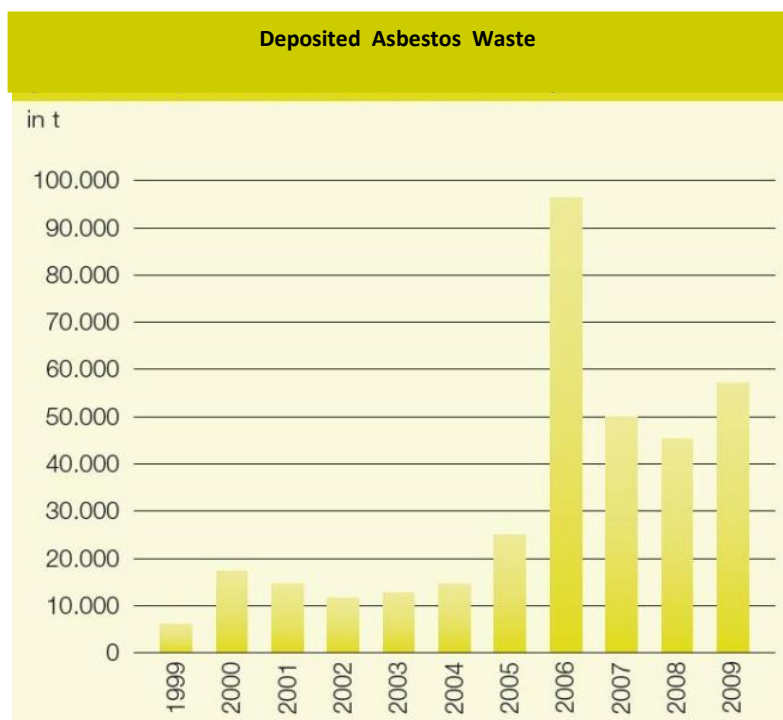

Figure 3.30. Deposited Asbestos Waste in Austria (Abfallwirtschaftsplan 2011).

Hazardous Substances

The amount of hazardous substances which ended up in treatment installations in the year 2009 in Austria was about 957.000 tons. Among them 806.367 tons were turned into non hazardous waste in the waste treatment installations. Moreover 81.500 tons were imported from other countries in order to be treated in Austria, where a variety of treatment installations is available. According to the Waste Management Law Regulation (AWG) 2002 since July 2001 depositing hazardous substances on landfills is prohibited. Dangerous waste should receive special treatment and be turned into non hazardous waste before landfilled. The very toxic substances which cannot even after treatment end up in landfill are either buried in underground storage or exported to other countries. Dangerous substances are those included in the Waste Catalogue Ordinance (Abfallverzeichnisverordnung, BGBl. II Nr. 498/2008) and the contaminated soil in contact with such substances (e.g. in factories of chemical industry, oil tanks etc.)

Waste which was lead as hazardous in the treatment installations in the year 2009. Ranking according to the largest masses.

Key numbers Waste designations in accordance ÖNORM S 2100 with consideration of changes in the Waste Catalogue Ordinance.		Masses in tons rounded	Percentage of the total volume of hazardous waste
31223 + 31223 91	Dust, ash and dross from other smelting processes	82.823	8,7
31424	Other contaminated soils	74.814	7,8
31412	Asbestos cement	56.055	5,9
31423	Oil contaminated soils	53.446	5,6
35203	Vehicles and machinery with environmentally significant amounts of hazardous components or ingredients (e.g. starter batteries, brake fluids, motor oil).	52.847	5,5
31309 + 31309 91	Fly ash and dust from waste incinerators	48.141	5,0
54102	Oils	34.334	3,6
31211	Salt slag	34.208	3,6
31308	Slag, ash from waste incinerators	33.913	3,5
17207	Railway sleepers	26.756	2,8
54702	Oil or benzin separator contents	26.447	2,8
54402	drilling anf grinding oil emulsions	25.046	2,6
31484	excavation, fill in material from CP Installations	23.849	2,5
54408	several oil water mixtures	18.893	2,0
52725	several aqueous concentrates	17.842	1,9
55374	solvent-water mixtures without halogenated solvents	16.157	1,7
55370	solvent mixtures without halogenated organic compounds, dyes and paint thinners (e.g. cellulose thinners) and anti-freeze.	15.556	1,6
35322	lead and batteries	15.182	1,6
52102	acid, acid mixtures, inorganic	14.174	1,5
54703	sludge from oil separator plants	13.711	1,4
35230	electrical or electronic equipment and devices with an edge of less than 50 cm with hazardous properties	13.000	1,4
54701	sand trap contents , oil or cold cleaning substances	11.886	1,2
94801	sludge from sewage treatment, containing dangerous substances	11.777	1,2
31217	filter ash, non-ferrous metals	11.339	1,2
51112	several galvanic sludges	11.250	1,2
35212	screen devices	11.166	1,2
57805	dangerously contaminated fractions and fly ash from shredders	11.004	1,2
31633	glass grinding sludge production with specific harmful admixtures	10.666	1,1
54930	solid fat and oil contaminated equipment (workshops, industry and gas station waste).	10.420	1,1
	Sum	786.700	82,2
	Another 48 types of waste (1000 until 10.000 tons/year)	136.553	14,3
	Other 254 types of waste (less than 1000 tons/year)	33.565	3,5
	Total	956.818	100

Table 3.4. Hazardous waste Catalogue in Austria (source Abfallwirtschaftsplan 2011).

Treated dangerous Waste 2009 - Treatment after successful treatment			
Key Number	Waste Type after Treatment	Specification	Treated Mass in tons
31308 88	Slag and ash from waste incineration plants	treated	228.786
31424 37	Several contaminated soils	Excavated soil and excavated material once treated are not dangerous	203.618
54504 88	With crude oil contaminated soil, excavation and demolition material	treated	121.342
31309 88	Fly ash and dust from waste incinerators	treated	79.147
31423 36	With oil contaminated soils	Excavated soil and excavated material once treated are not dangerous	24.339
31484 88	Excavated material and fill material from the chemical /physical treatment	treated	22.322
31203 88	Slags from non-ferrous metal melting	treated	16.000
31301	Fly ash and dust from other combustion plants		13.000
31411 29 31411 33	Excavated soil	Excavated soil material with background exposure Class A2, Demolition and construction waste	12.091
31314 88	Solid residue containing salt from flue gas cleaning of furnaces for conventional Fuels without (FGD gypsum)	treated	11.500
54503 88	crude oily sludge	treated	10.100
	Another 20 types of waste		59.070
	Waste without SN		5.052
	Total		806.367

Table 3.5. Treatment of dangerous waste in Austria (source Abfallwirtschaftsplan 2011).

chapter 4

INTERVIEWING EXPERTS

This chapter links the previous chapters with the everyday demolition practice. The interviews took place in Vienna and the conclusions presented in p. 87 refer to design practices and law regulations current in Austria. The guidelines presented in p.46 were found out in the current bibliography and were included in the questionnaire of the interviews. The questionnaire aims to find out which sustainable design criteria are taken into consideration by design offices and which not. Is demolition a concern of the architect at the design phase? What are the main impediments to introduce demountable structures and recovered material into the construction industry. In addition, several researchers from the waste management field were asked their opinion about the way demolition waste should be treated in the future and about what the contribution of architectural design could be towards waste reduction.

4.1 Interviewing waste management researchers

Vienna 20 October 2011

Interview with David Clement, Research Assistant at the Institute of Water Quality, Resources and Waste Management of the Technical University of Vienna.

1. Which is the most common way to demolish buildings in Austria. Through demolition, selective demolition or deconstruction?

D.C. : Most buildings are broken down by selective demolition. The building is deprived of hazardous waste first, then stripped of its reusable components and then demolished.

2. But is this a compulsory way to demolish buildings. Is it institutionalized by law or is it just happening in some cases?

D.C. : Most buildings are demolished with selective demolition, except probably from some rare cases in the countryside. In Vienna in particular before demolition takes place a Waste Management Concept always has to be set to define the demolition strategy and the handling of the waste. However this is not always easy, because the difficult part is to find the record concerning the material included in the building.

3. When you say record, do you refer to the construction designs?

D.C. : Yes, but also to renovations and changes, nobody keeps record of the material chosen during that time, and what substances these materials include, so that we know later how to deal with the deconstruction waste. Most of the building debris needs chemical analysis to find out exactly what the content of the debris is, but such an analysis takes time and cost and in most cases it doesn't take place. The debris ends up to landfill.

4. In different scientific papers I found lists of construction materials which are considered to be toxic. There is also a scale for their toxicity. For instance Asbestos and Chromium are ranked as highly toxic substances compared to Zinc let's say, which is supposed to be less toxic. What exactly is this toxicity about and how can it be avoided, excluding toxic material from the construction industry can be a solution?

D.C. : Actually toxicity is mainly related to the concentration of a substance. For example 1 mg of Chromium is much more toxic than 1 mg of Zinc in the drinkable water. There are impact categories to define toxicity, like impact to sea land, flora and fauna etc.. Asbestos was proved to be a very toxic substance, which has to be selectively removed from the building with a special procedure and trained workforce before it is demolished. Once the building is crushed, one cannot separate the toxic substances from the rest of the materials. The heavy metals are generally toxic, but there are standards which define the limit of their concentration in the building elements. In concrete for instance standards allow a specific amount of heavy metals concentration. But the main problem is that heavy metals are present in many applications. That's because most materials are composite. In the past remaining smithereens of lead or other heavy metals were used to fill in the void within slabs or chromium is contained in mortars. Nowadays there are paints in market containing pesticides to restrain the growth of mold. It is a very complicated issue, most materials contain additives, glues or toxic heavy metals in tiny quantities etc. The evolution of nanotechnology reinforces this practice by applying properties of one material to another, but the final mix is not separable later on. On the other hand researches which related to treatment of toxic substances may last for years, like with asbestos it took long time to prove its toxicity. So excluding toxic substances from the construction industry is not easy in practice.

5. In the selective demolition, some components like windows, doors, fireplaces, staircases are removed from the building and reused in some countries. Turkey for instance has a second hand material market at lower prices, which serves the construction of cheap residential complexes for the mass population. Is there something similar in Austria? What happens to these salvaged components after the building is demolished?

D.C. : Officially we have no data about such a market, like the one you are suggesting in Austria. Some of the salvaged building components are sold to other countries or they are crushed and recycled if possible.

6. Wooden or metal elements, plastics and glass, none of them is reused? Are they all recycled?

D.C. : Most of the material mentioned are recycled. Wood for example, it is so rare to find natural wood. Most wooden elements are made of ply wood which contains different kind of additives and glues. Ply wood is a product of wood recycling. With glass I am not quite sure if it recycled and how. But there is an unofficial way to judge if a building was properly demolished after selective demolition. If glass is found in the debris, it is a sign that the demolition didn't take place selectively. Glass is also a material demounted from the building volume before demolition.

7. There are different types of insulations in buildings. biodegradable ones like sheep wool and cellulose and synthetic ones like urea formaldehyde. Which one is it the most common in construction, would you recommend it?

D.C. : The most common insulation is styropore. It is used in the 80-90% of building construction in Austria. It is plastic and it is cheap. I also used it my house. Styropore is glued on the outer wall which makes the separation after demolition quite difficult. Alternative insulations which do not create such a problem are biodegradable like sheep wool and cellulose as you mentioned, but mineral ones

as well. Light concrete with air cavities can be used as external insulation and when the building is demolished it remains in the deconstruction debris and can be recycled as structural concrete.

8. In the case of styropore what would you recommend for architects who design according to the Design for Deconstruction principles? Is there any way for such an insulation to be reusable and not end up to landfill?

D.C. : I think some mechanical joints to mount and demount the insulation on the wall should be invented by architects, but in any case keeping record for the type of insulation chosen would lead to a better Waste Management Concept when it comes to demolition.

9. When the demolition takes place who is responsible for the process? Who decides the Waste Management concept and signs the contract for the demolition process?

D.C. : Usually big construction enterprises who will construct another building at the deconstruction site. PRAJO for instance is the most famous one in the time being, it undertakes the largest amount of demolition processes in Austria.

Vienna 11 November 2011

Interview with Prof. Paul H. Brunner, Head of the Institute of Water Quality, Resources and Waste Management of the University of Vienna

1. Prof. Brunner it is common for most buildings in Austria and in other European countries that after a building is demolished, the construction debris is reused or recycled. This master thesis is about Design for Deconstruction. In order to save on energy and natural resources construction materials are increasingly recycled or reused. In what way could architectural design contribute in optimizing the demolition and material reuse?

P. B.: First of all it has to be clearly stated if the thesis aims to optimize the waste management today or if the goal is to optimize the design for a deconstruction which will take place 50 years from now. Because nobody was thinking about demolition and recycling when those buildings were designed in the past.

2. This is a very important remark. The thesis aims to set design principles for the buildings which will be constructed in the future. But the concern arises from the limit of the natural resources we have on our disposal. Which natural resources are we mostly running out of? Is it metals, stones, wood in Austria for example?

P.B.: For more detailed information about your question you should contact the RMA (Resource Management Agency) a department specialized in natural resources. However I personally should tell you that the natural resources management is dependent on the market. If we run out of a specific resource, for instance iron, the price of iron will get higher. The environmental impact is another issue. We use iron because it is cheap and the market doesn't care about the resource scarcity. Researches aiming to preserve the scarcity of resources in the next 50 years are not funded by the market, because we do not know how the state of the technology will be in the future.

But if we do not recycle, then we will run out resources...

P.B.: The price will get higher for the market! In case we run out of resources, then we will recycle and industry will adapt. But it doesn't matter if the iron is in the ground or out in the surface for the market. Generally researches with a long term from the financial point of view nobody would invest on such a long term research. I do not necessarily agree on that, but this is how the market works.

3. I see, the EU Waste Framework Directive though having taken into consideration the market needs set some standards for Europe. According to these standards a percentage of 70% of construction material should be recycled by the year 2020. The need for recycling is officially significant. How could this process be optimized by architects?

P.B.: I think architects could contribute in avoiding the environmental impact by setting some general principles which will be true in 50 years from now. For instance, the higher the mixture of materials in a building, the more energy we need to take them apart. Architects cannot know today what demolition tool and strategies people will evolve in 50 years when the building will be broken down.

4. As far as toxicity is concerned, there are some materials very essential for the building industry which are classified to be toxic like cadmium, lead etc. . How could toxicity be avoided by design?

P.B. : We cannot avoid the toxic materials, we could avoid their dispersed form. Lead for instance is a toxic material and it should be avoided mixed with other material. Lead is usually included in paints, but it is dispersed and it is impossible to separate it afterwards.

5. In Turkey there is a market of second hand building components like windows, doors etc. As far as I know there is no such a market in Austria. Could such a market be a solution to save on energy and material?

P.B.: Well in Turkey there is such a market because there is a demand as well by lower budget social class. The social differences are intense in Turkey, which doesn't happen in Austria. But yes, a second hand building components trade is a sustainable solution and could be profitable if those components were exported in other countries.

Interview with Mag. Heinz Buschmann , scientific member of the Ressource Management Agency of Vienna.

1. What percentage of the buildings are demolished by: a. conventional demolition, b. selective demolition c: deconstruction?

H.B.: There are no data on the methodology used in the demolition work. All figures are based on estimates and are subject to strong variations depending on the type of property and region.

Starting from the less sophisticated and less expensive, demolition methods could be ranked as follows:

a. demolition, b. selective deconstruction, c. reuse oriented deconstruction, d. demolition free deconstruction

An estimate of the practice of these methods is approximately:

- 2/3 demolition and partly selective deconstruction
- 1/3 selective and reuse oriented deconstruction

2. In Austria is there any Waste Management plan set before the Demolition? What includes actually such a plan?

H.B.: From a certain amount of construction waste upwards, a material separation and reuse of the debris is required. (see BaurestmassentrennVO).

In itself the demolition of any building doesn't require a waste management concept.

In Salzburg and Vienna a waste management concept including an identification of toxic substances is realized for buildings of total volume 5000 m³ or 1000m length. Otherwise it not a prerequisite.

The action taken is described in the Federal Waste Management Plan (Bundesabfallwirtschaftsplan 2011).

3. Which components are removed in case of a selective deconstruction (e.g. Windows, Doors, etc.)?

H.B.: The selective or so-to-say reuse oriented deconstruction defines which construction components toxic or useful substances are contained in the building and how these material stream will be disposed or reused in the best way. The most important thing is the material related examination.

Removed components are the following:

The roof

The floor coverings

Window and door frames

Window and door sheets

Construction Wood

4. How are these components going to be treated later on?

H.B.: The way of material reuse or disposal depends on the quality of the construction waste and the available market. High quality recycled products can possibly be sold and reused. But if there is no market to absorb them or at least some infrastructure to substitute the raw material with recycled ones, the waste mass will be disposed. The landfill taxes is very low in Austria after all, and there are plenty of raw material wood, minerals etc. In other countries like the United Kingdom where they do not have the same abundance for resources, one can find high quality recycled materials.

5. Then who is responsible for the waste which is produced?

H.B.: The company which undertakes the demolition of one building to build another . In most cases the waste is land filled. The statistics in the Abfallwirtschaftsplan do not respond exactly to what is happening, they are based on specific buildings which were indeed demolished with a demolition plan. But this is not the case for every single building because it is expensive.

6. On what depends this high cost?

H.B.: On removing the contaminated components, like those containing asbestos for example. It is not easy and it always depends on the type of the toxic substance.

7. A quite big issue is the application of oil products for building insulation, like polystyrol for example, which are mostly glued on the outer wall surface . This kind of insulation will be toxic if landfilled. Design for Deconstruction could contibute on an easier material separation after deconstruction. Do you find feasible such a concept?

H.B.: I think that from now we should consider how to recycle buildings with insulation .Design for Recycling / Design for Deconstruction are not widely applied for the moment (just in pilot programm).

Establishment of the cycling thinking in construction sector must come and be lived.

metals	90% recycled
glas	80% recycled
PVC	80% recycled

12. Which removed components can be reused? Is there any market for reusable materials, like in Turkey for instance?

H.B.: There is no market for reusable components. A very small proportion of the market is interested in historical components like furniture, fireplaces, house equipment etc. Successful reusable building components market exist in Germany , Netherlands and Switzerland.

13. So what happens with windows for instance and doors in Austria after they are selectively removed from the building?

H.B.: It depends, if the windows are from aluminum , both the glass and the aluminum are recycled. If the frame is wood or plastic then they are burned in furnaces. There are special high temperature furnaces for plastic.

14. What kind of waste with which you are confronted with is considered as toxic? How is it treated?

H.B.: Asbest,

Copper compounds

Lead

PCB (Pentachlorphenol)

PCB (Polychlorieriated Biphenyle)

PVC

15. Researches in architecture field are oriented towards the reduction of waste, through the design of demountable structures and reusable components. How feasible do you consider such structures in praxis? Did you ever have to deal with demountable structures?

H.B.: Structures designed for deconstruction and components which can be deconstructed are desirable but for the moment they do not take place. It is very important to think about the recycling quality of the buildings we construct.

16. Which resources are we running out of (minerals, wood, brick etc). Reusable components could be environmentally protective?

H.B. In Austria there are plenty of resources for minerals.

However the Austrian Mineral Resources Plan shows that because of conflicts about the exploitation of raw material among the building industry , the transportation network industry and the natural protection department , the abundance of these resources will reduce.

The rise of the price of raw materials will lead to expensive construction .

4.2 Interviewing architects

Vienna 23 November 2011

Interview with Kristina Schinegger, University Assistant at the Architectural Theory Department of the Technical University of Vienna and Mag. Architect member of the SOMA Architecture Office in Vienna.

1. Mrs. Schinegger, this research is about design for deconstruction and construction waste management. I am aiming to find out how architects could contribute to design for recycling or for deconstruction as long as the new structures are concerned. Nobody was thinking about it in previous years, as a result today we have to deal with a huge amount of mixed waste and toxic waste, which harms the natural environment when disposed to landfills and at the same time we start running out of natural resources. You are already in the design industry. How concerned are architects about such a design concept?

K.S.: I do not think that architects consider much about the demolition of a building or about the recycling capacity of the construction debris. Usually we deal with waste after it is created than before. And I think the material lobby is responsible for that. As far as architects are concerned I have two main concerns for your research:

1. The first concern is :can we know how the buildings are going to be in 30 years? If the client doesn't care about how the demolition of the building is going to be and if there are no standards to guide the design, then why should we take the demolition parameter into consideration, which will probably require time and money. The client will not pay for such a design because , he doesn't care.
2. The second concern of mine is that such design concepts and practices have to be in accordance with general political and economical strategies. The architect is always trapped among many aspects (social, political, economical) which contribute to final design and cannot decide always on his own.

2. To your information before we move on to the standard questionnaire I think I should let you know about the latest articles of the European Directive 2008 about recycling of deconstruction material. Until 2020 all European countries should recycle the 70% of their deconstruction waste. The European council sets some standards but nobody says how is this possible? In many European countries like Germany, Netherlands and the UK recycled material is a substitute for raw materials and selective deconstruction has replaced conventional demolition. In Austria high percentages of the deconstruction material is recycled as published in the Abfallwirtschaftsplan 2011. Because of the fact that there are no standards yet, I am contacting architects to find out their most current concerns and obstacles towards the establishment of some standards. The following questionnaire will help in this direction.

1. When you design a residential or commercial building how long do you expect it to stand before it is demolished?

0-25 years 25-50 years 50-100 years 100-...years

K.S.: When you design a building you do not exactly know how long it is going to last. It always depends on the type of the building. I have not dealt that much with residential buildings but rather with cultural and temporary ones. For example one of the pavilions we have designed it was a sculptural one, which was expected to stand for approximately 30 years.

But to come to your question, when an architect designs a residential building he responds for 30 years approximately, then the building is refurbished or renovated or demolished. We do not know what the owner intends to do from that point onward. And people usually want their house to last for a lifetime.

2. While designing a building, do you consider how it will be demolished or disassembled?

K.S. Actually no, this is a matter that could influence design at the implementation planning (Ausführungsplanung) or when it comes to choose materials in the catalogues.

3. Have you ever heard about Design for Deconstruction (Dfd)?

K.S.: No to be honest.

4. When you choose materials for your building which are the top 3 criteria that define your choice? Answer placing the most important first.

1.cost

2.aesthetics

3.localavailability

4.ecologicalimpact

5.potential to be reused after demolition.

K.S.: The aesthetics is a very important factor, for our office at least. Then the cost is the next concern. You usually pose the question to yourself: I like it, can I afford it? Then the local availability is also a desirable condition, but it is not always possible. When we designed the Expo Pavilion in Korea all of the material we used were local. We did not import anything but the rules were obliging us to do so. The ecological impact is also an issue, in a sense that one should use material in a responsible way. For example we cannot cover the whole building with a rare or expensive material which is not compatible with the weather conditions or the functioning of the building in general. The last criterion "potential to be reused after demolition" well it should be taken into consideration but it is not the first that would come in my mind.

5. Many of the building materials contain substances which cannot be landfilled without previous chemical treatment. Such substances are considered toxic like: asbestos, antimony, cadmium, lead, mercury etc. Do you consider toxicity when choosing material for buildings? If yes in which way?

K.S.: Toxicity of materials is a matter that influences the Implementation planning and the material selection from material catalogues. Of course we avoid asbestos, mercury and lead. But I do not spend that much time with implementation planning.

7. In your recent projects what percentage of your building materials is imported from other countries? What kind of material is mainly imported?

K.S.: Very little percentage is imported.

8. Do you use recovered material in your projects?

K.S. :Yes, but just for foundation

9. A buildings' wiring and piping system might occasionally need repair. How could this in your opinion be included in building design so that such a repair does not cause construction work?

K.S.: This is usually achieved by elevated floors in public buildings for instance. I do not think that this is always happening in houses. But pipes can be easily accessed if the floor is removed partially, and this way one avoids the construction waste that breaking the wall or the floor would cause.

10. When you design composite construction details, do you pay attention to the potential for their material separation and reuse in the demolition phase?

K.S.: Honestly no. I was not much aware of that.

I would like to give an example to make myself clear. The material used for external insulation is in many cases plastic like polystyrol for instance. This type of insulation is glued on the outer wall and when the demolition takes place it cannot be separated from the mineral waste. Ending up to landfill or to backfill the polystyrol mixed with the minerals will pollute the soil and the aquifer as the years go by, because it is not a biodegradable substances. If we could for instance replace the glued method with a mechanical fixing of the insulation on the outer wall then these material would be easily separable after demolition. What is your opinion about such design practices?

K.S. :I think people tend to do crazy things. On one hand they set sustainable standards and they give certifications, and on the other hand all new constructions are covered with 30cm thick insulation made of this poisonous plastic. I mean what will happen when all these buildings will be demolished as you say? And the different Environmental Organizations have set all these limits of CO₂ emissions for each country, but we buy the emission amount from poorer countries like Ghana let's say, so that we can emit more. Sometimes all these strategies make no sense. And as an architect you are trapped trying to satisfy different and conflicting requirements. Sometimes you make something out

of composite material to reduce weight and transportation costs. Sustainable material are also heavy and that a disadvantage.

11. When a building is about to be constructed, do you keep a record of all the material used to construct the building (apart from the construction plans)?

K.S.: I am sure there is a list of everything. When we have to submit the construction plans to the urban planning department they ask information about everything till they accept the construction of the building.

Vienna 29 November 2011

Interview with Arch. Dipl. -Ing. Bernard Sommer University Assistant at the Applied Arts University of Vienna.

1. Prof. Sommer with your experience in energy design and sustainable architecture, when you design a building how long do you expect it to stand before it is demolished?

0-25 years 25-50 years 50-100 years 100- years

B.S.: From the technical point of view we are responsible for 30 years after a building is constructed. Then buildings are renovated or remodeled. So technically I would say I design buildings for 30-50 years, but it depends always on the type of the building. Urban structures should stand technically for a longer time than detached houses at the countryside.

There are standards stated in the Planerhaftung (liability planner) which define the technical durability of the new constructions.

Functionally, in my office we do not plan for such a long time, we design buildings with a possibility to be changed and remodeled during these 30 years.

2. While designing a building, do you consider how it will be demolished or disassembled?

B.S.: Yes in a way, but it always depends on the structure and the construction system it is made of. For instance in concrete structures I try to leave free the interior without the interval of concrete walls which will have to be broken down in order to renovate or remodel the building. In wooden structures and generally temporary structures one has to think about the deconstruction method as all these components will have to be dismantled and carried away from the construction site some day.

**3. Have you ever heard about Design for Deconstruction (Dfd)? Yes / No?
Please explain your understanding of this notion.**

B.S.: Yes I have heard about it and about demountable structures as well, but in practice I haven't dealt with it. If we could know more about that kind of design maybe we could introduce it in our designs. But there are no standards as far as I know.

4. Exactly. That is the goal of this research to take the Design for Deconstruction or Design for Recycling one step further and define some basic guidelines for architectural design, which who knows maybe someday will be officially enriched with further information and recognized as standards!

B.S.: Well that would be very challenging for architecture because it changes the whole design process. But it sounds very interesting.

5. When you choose materials for your building which are the top 3 criteria that define your choice? Answer placing the most important first.

- 1.cost**
- 2.aesthetics**
- 3.local availability**
- 4.ecological impact**
- 5.potential to be reused after demolition.**

B.S.: First comes the aesthetics for sure, cause I am an architect. Then I am always concerned about the ecological impact of the product. I always work with sustainable products. And then the local availability is also an important factor.

6. What about the cost? Isn't it a very important criterion? How do clients react on that?

B.S.: The cost no, I always prefer very expensive solutions. In the beginning of my carrier I was taking it into consideration, but now I came to the conclusion that a smart client tries to get a building of a good quality and not a cheap building. My clients are also very specific. I 'd rather use harmless and expensive products of a good quality than cheap ones. I never use styropor or styrofoam for instance for they are oil products and they are not air permeable.

7. Many of the building materials contain substances which cannot be landfilled without previous chemical treatment. Such substances are considered toxic like: asbestos, antimony, cadmium, lead, mercury etc. Do you consider toxicity when choosing material for buildings? If yes in which way?

B.S.: I try to consider it and if I know it I try to avoid it. I avoid the well known toxic substances like asbestos or PVC because when it is burned it emits toxins. But it depends you might use some toxic substances if there is no alternative. For example once I had designed a pavilion standing outdoors where there was no danger of fire and it was made of PVC. But if I deal with a place with high fire potential I might use asbestos if there is no alternative.

8. In metal or wooden structures which type of joints do you usually choose: nails, screws, bolts, resin bonding, adhesives, or welded connections? (you can add in your answer other types of connections if used)

B.S.: For steel structures I prefer to bolt steel wherever it is possible, but some welded connections cannot be avoided. When I use laminated wood, I also use bolts. Laminated wood is the only form of wood it can be easily worked on. However the glue within the laminated wood panels cannot be avoided.

9 In your recent projects what percentage of your building materials is imported from other countries? What kind of material is mainly imported?

0-25% 25-50% 50-75% 75-100%

B.S.: I usually choose local products , but I would say the imported products are among 25-50%. Because talking about local availability, when I am in Vienna I prefer to use a good quality products

from Hungary or Slovakia than from Tirol which is at a longer distance. I would define local availability in terms of kilometers of distance.

10. Do you use recovered material in your projects (eg. bricks, metal beams etc.)?

B.S.: Almost never, because they are not available on the market. To trust a reusable material I have to make a research first, to see what is available on the market and look at the standards, there is not such a thing in Austria. But steel as far as I know or aluminum which are recycled in many cases could be a sustainable choice. In that point of view I would use recovered materials.

11. In Turkey there is a market for second hand windows, doors and lavatory equipment, which are usually used for residential buildings of the lower social class. How do you find this idea? Would you ever use such products?

B.S.: The idea sounds very interesting. Why not? We could use such products as long as we have standards for them. But for the moment there is no certification for reused products.

I know a project of Klaus Stattmann, the FLUK, a club here in Vienna at the Prater region. For that place there was no money to be erected, so it was built with donations of doors and windows etc. and it was finally built this way. I also remember one of my projects was an historical building and I used a door, a salvaged door from an older historical building for that project. But these cases are rare and unfortunately there is no such a market for the time being. Apart from that, such a design of reusable components is less creative and more standardized, because these components will inevitably be predefined.

9. A buildings' wiring and piping system might occasionally need repair. How could this in your opinion be included in building design so that such a repair does not cause construction work?

B.S.: By dimensioning the channels and making them accessible. I would try to integrate them in the wall or the ceiling.

13. What about integrating them in the floor? Is it not a more easy access for repair?

B.S.: Well yes it is. In office buildings it is already a standard. But for single houses I do not think it is necessary. Repairs are more rare and there is not that much cabling to justify elevated floors. Maybe it could work in housing complexes.

10. When you design composite construction details, do you pay attention to the potential for their material separation and reuse in the demolition phase? For instance insulation is mostly permanently fixed or glued on the brickwork, as a result when the building is demolished the plastic insulation ends up to landfill along with the mineral waste. This waste is toxic and responsible for soil erosion and the pollution of the aquifer. If the fixing of the insulation on the brickwork was mechanical, then it could be separable and all the plastic would be treated separately then the rest of the brickwork. Have you ever tried such practices?

B.S.: I like to think about material separation. In facades for example I am concerned if panels can be detached from each other or from the main structure. Concerning the insulation that you mentioned I try to keep myself up to date with the most sustainable practices but honestly I haven't used such a practice, because I didn't know it is available.

11. When a building is about to be constructed, do you keep a record of all the material used to construct the building (apart from the construction plans)? The problem with the demolition of a construction is that one never knows what material they are going to be found once the building is broken down. And that is because no list of the material input was kept during the construction.

B.S.: There should be a list. You define the type of the quantities of the material before you start to build according to the Austrian performance building standard directory. It is interesting to use this information as a guide for deconstruction. I had never thought about it.

RESULTS AND DISCUSSION

5.1. Conclusions on demolition waste management overview

As it results from the second chapter, there is already the appropriate technology in our disposal to separate the demolition waste into mineral and non-mineral aggregates . Mineral aggregates include stones, bricks and cement which are crushed and fragmented into gravel for backfilling or sand for road base construction and sport terrains.

These mineral aggregates can be either stone, brick or cement aggregates in pure form or mixtures of them. Stones can be separated from binding mortar, so that they may be reused. Concrete and bricks are however downcycled, as they cannot be reused for their initial purpose. Only a small percentage of concrete can be reused in raw concrete aggregates to produce structural elements. Researches to reuse bricks are in progress.

Wood and plastic elements are incinerated or recycled . The recycling of plastic results in downcycled material as in this process the polymer chains lose their elasticity. Wood, on the other hand, may be recycled by being broken down into grain size particles material, which may then be used for production of plywood. Steel and aluminum are already recycled without resulting in downcycling.

5.2. Conclusions on design for deconstruction overview

Design for Deconstruction is a new design approach to reduce demolition waste. This problem is dealt with in the third chapter, resulting from the fact that buildings under demolition today had not been built with the objective in mind of reusing or recycling the demolition material. Design for Deconstruction targets to deconstruction of buildings whose material stream will be reused when they are demolished. As there are no official standards on how to design demountable structures with reusable components, this chapter introduces a number of design guidelines for making possible material separation and recovery after demolition.

Material separation is also aiming to the isolation of toxic substances from the rest of the material stream. The highly industrialized European countries have already taken action for recycling waste as the amount of waste they produce is a lot more than that of the less industrialized countries. In the first category countries like Germany or the Netherlands have already advanced in the creation of guidelines on that, while well documented case studies have already been made. However, the extend of deconstruction practices are still very limited as this will start expanding when buildings designed today for deconstruction will be demolished at a much later date.

Deconstruction waste, however, may also be high in countries with smaller degree of industrialization, but with a big population like Turkey, where no guidelines have yet been instituted in this regard. What we are observing in Turkey is the existence of a second hand construction materials market, which is addressing in the same problem in an empirical way.

Reusing of materials appears thus to be an objective in all places, certainly achieved in different ways and different levels, as it is described above, since in this way downcycling is avoided and energy is saved.

5.3 Conclusions interviewing waste management experts

The findings of this research are mainly related to practices in Austria, because the interviews were realized with experts working in Vienna. All information regarding other countries is based on scientific papers. The demolition methods considering the time, cost and complexity involved may be classified in the following categories, each one of them having its advantages and disadvantages as follows:

A. Conventional demolition

Advantages: As long as landfill taxes remain low, it is the cheapest, less complicated and the most easily applicable solution for the moment.

Disadvantages: Conventional demolition is not a sustainable practice to break down a building because it enables no material recovery. The great disadvantage of conventional demolition is that once the building is crushed the separation of toxic waste is impossible. According to the waste management researcher David Clement a chemical analysis is required before the waste results into landfill, but this doesn't happen in most cases because it is expensive. Most of the demolition debris mixed with toxic material ends up to landfill with huge ecological negative impact.

B. Deconstruction

Advantages: no material waste and no extra energy for recycling.

Disadvantages: An implementation of such a design in the moment would require extra time and cost clients are not willing to pay for. Deconstruction requires a design for deconstruction in advance.

The design studios and the construction industry need the appropriate time to adapt to such an innovative design practice. Deconstruction can more easily apply with wooden or steel structures, while concrete buildings cannot be demounted in their totality in the way they are built today.

C. Selective demolition

Advantage: it is the most applicable solution today to dealing with the waste in a sustainable way. It is recommended for concrete structures and all the buildings which have not been built under a deconstruction plan.

It allows material recovery and toxic components removal from the building, so that they can be treated later separately as toxic waste. What remains from the building structure can be demolished and then recycled or landfilled without serious consequences to the environment.

Selective demolition should be applied in all European countries to reduce the environmental impact of the demolition waste, but it remains less sustainable than deconstruction.

Disadvantage: The disadvantage of this practice is that recycling is always worst than reusing. Recycling requires extra energy to produce a good quality recycled product. Selective demolition doesn't always save on energy and money. But it saves on raw material extraction and toxic waste. It is an expensive and sophisticated process which requires trained workforce. For the moment it is the most suitable demolition strategy for the existing buildings.

Keeping demolition record

As the waste management researcher Mag. Heinz Buschmann stated, no records on the methodology used in demolition work are kept. All figures are based on estimates and present big variations. The more systematic the approach on selective demolition is, the easier will be to apply it on a wider scale in the future on a larger scale. Not only data on selective demolition practices should be kept, but also standardization methods have to be established in order to keep control on the quality and quantities of waste produced.

Further action towards the official establishment of selective demolition

By interviewing architects, I realized their difficulties and probably confusion trying to compromise between their design solutions and their clients' demands, financial limitations, law regulation and sustainable practices which are contradicting with each other. Architects themselves alone cannot support Design for Deconstruction if at the same time law regulations and the people are not motivated towards this direction.

The European Union in the EU Waste Framework Directive (2008/98/EC) demands a percentage of 70% material recycling of the demolition waste from all European countries until 2020. But there are no further directions of how these standards will be achieved when European countries have so big differences as to the disposal and recycling practices they are applying. Taking into consideration the equation of the demolition contract amount:

$$\text{CONTRACT AMOUNT} = \text{COST OF DEMOLITION} + \text{LANDFILL COSTS} - \text{REVENUES}$$

We are coming to the following conclusions:

If the demolition practice for a conventional building is the selective demolition then the cost will be higher, as this is a more sophisticated and expensive solution, as compared to that of conventional demolition. More specifically:

- a. The cost of demolition as such is more expensive
- b. The landfill cost is the same under both methods
- c. Therefore, the revenues is the factor which may vary and make the difference as to which method is preferable. Under the conventional method revenues is zero, while under the selective one, revenues may vary and be higher or lower depending on the value of the recovered materials. If that value is higher than the difference in the cost of demolition, then the selective obviously becomes the preferable method. If not, the conventional one is the preferred method.

Therefore, the selective demolition becomes preferable if revenues from recovered materials can be high enough. This implies that a market of second hand doors, windows, lavatory equipment fireplaces etc. could be a profitable business and a very sustainable one on the same time.

Instead of selling products fabricated by raw or recycled materials, the market could merchandise second hand materials reducing on energy consumption and raw material extraction.

These second hand products should be cheaper than the raw material fabricated ones, in order to motivate the public to buy them. In case these products are not desirable in countries with high standard living, poorer or developing countries would be more interested to buy them.

The public should generally be sensitized towards the design for reuse or recycling and their taste should be driven to reusable components. As long as architects are concerned, they definitely need standards and guidelines officially established to convince client for the necessity of design for deconstruction.

5.4. Conclusions on interviews with architects

The objective of the questions asked to them was to find out their awareness regarding the subject of Design for Deconstruction and the extent to which designs are made with this in mind. This way the benefits of the Design for Deconstruction method may be obtained at the time the building is demolished but also achieve a flexibility during the lifecycle of the building in making changes to it or remodeling it. The principles of Design for Deconstruction were presented in page 46. The questions of the interviews with architects intended to show if these principles are taken into consideration and if not why. The findings of the interviews are presented in separated design categories below.

1.The life cycle of buildings and planning for flexibility.

As the interviews reveal, the building lifecycle is determined by the design and other standards. Both architects pointed out that they are responsible for the first 30 years of a building's life. This in fact is what is specified by the Austrian state. After this period the building could be renovated or deconstructed. 30 years is a short time for a building to stand compared to the past. This fact further supports the belief that buildings should be transformable to adapt to the rapid socioeconomic changes, so that their life cycle is extended. The flexibility of the plan is already an important factor that defines the design process as the architect Bernard Sommer claims. Light structured internal walls panels enable rearrangements without any or with minor repair waste and cost.

2. Criteria for material selection in relation to DfD

Basically, there are 5 criteria for selection of materials to be used at the design of a building, namely the aesthetics, the cost, the local availability, the ecological impact and the potential for reuse after demolition. The criterion which architects put first in the priority of importance to them is that of the aesthetics. This is followed by the cost or the environmental impact and then comes the local availability. It is important to note the criterion of the potential reuse at demolition is the last one. There is a general notion between architects that the waste is off little concern to them at the time of design and is something to be dealt with after the demolition. This research shows that this is an irresponsible way to face the waste problem. In fact the design choices selected will make possible the optimal material separation and maximize the material recovery after demolition. Architects show concern about the sustainability of the material input in the building, but this concern should also include the use of recyclable and anti-toxic materials.

3. Material Toxicity

The use of toxic substances is sometimes unavoidable in the construction industry as they constitute irreplaceable constituents of components used in buildings, as for example heavy metals in the various pipes and cables. It should be avoided, however, their use in dispersed form, like lead in paints. Architects avoid the well known toxic substances like asbestos and chromium or lead. However they are not aware in detail about the properties of each toxic substance. A toxicity evaluation of the products used by the construction industry should be available, so that the harmless products are preferred compared to the harmful ones. If toxic substances are used in a

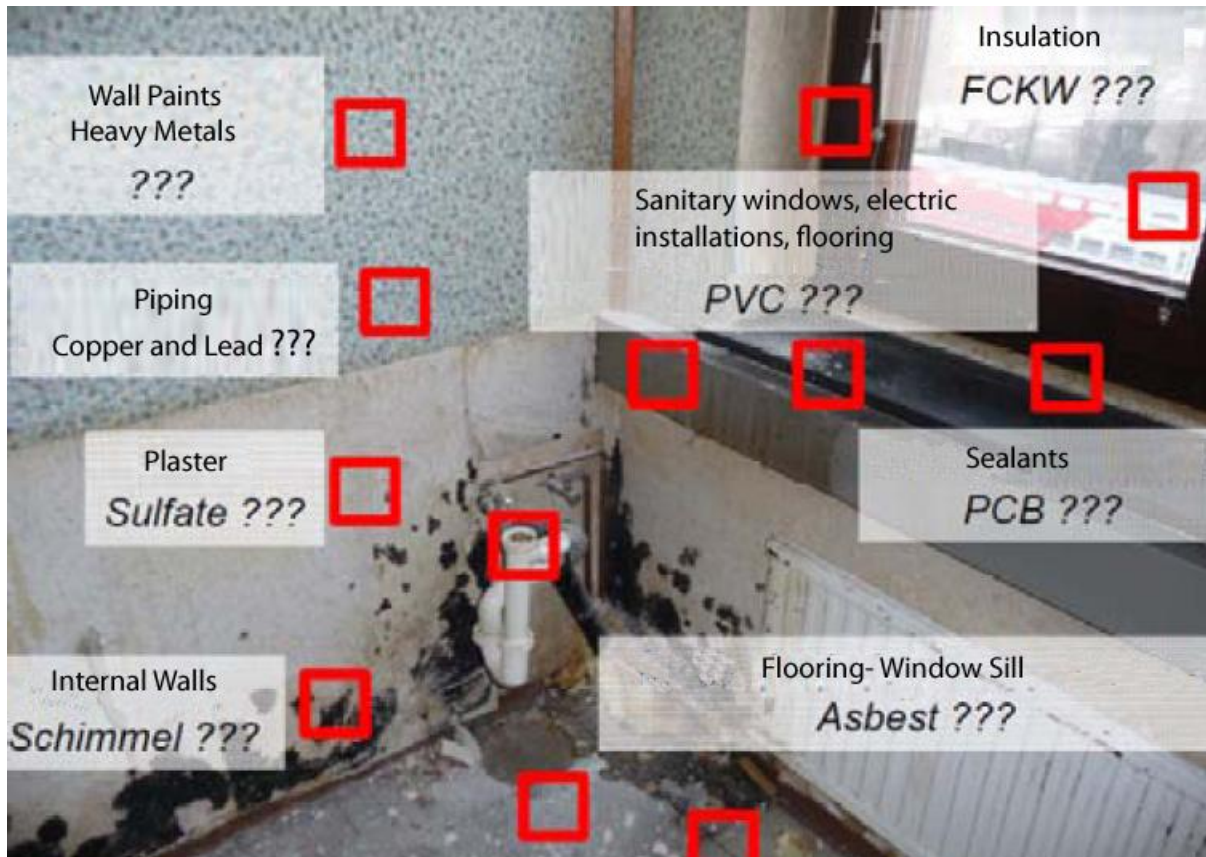

Figure 5.1. Selective Demolition. removal of toxic material (EnBa Schadstoffkatalog 2011)

building the designers should make known their existence and location, as well as the way for their removal at the time of the demolition.

Regarding the toxicity of the PVC components (e.g. insulation), it seems to be a lot of doubt about the sustainability in their use. Still 80-90% of the buildings in Austria are insulated with styropore, a PVC based insulation product, as David Clement, assistant at the waste management department of the Technical University of Vienna, claims. The impact of this material on the environment and human health will be huge if it results in landfills. Polystyrol insulations should be replaced by biodegradable ones like cork, sheep wool, cellulose or light concrete. If plastic insulation cannot be avoided, then mechanical joints should replace glues to fix it on the outer wall, so that it is easily demountable at the time of demolition. This way plastic will be salvaged after demolition and it will be not mixed with the mineral waste.

4. Piping and cabling

Architects have already taken steps for the easy repair of the piping and cabling system through elevated floors or suspended ceilings when dealing with offices or public buildings. These techniques should also be introduced in residential building, especially in large housing complexes, where the piping and cabling is much more complex than in single family houses.

5. Local products

Local material, basically wood and stone, are widely used in Austria by the designers thanks to the abundance of resources, as this makes the construction of buildings more economical. Material might be also imported from short distances if the transportation cost is lower than from other parts of the same country.

6. Recovered Material.

In Austria this remains a design field not yet explored. Most of the time architects make use of recovered material for backfill operations. The abundance of natural resources in Austria creates little interest for recycled material. However, waste management counselors are warning that the resources are not endless and in the future scarcity might arise.

Recovered or recycled materials like concrete are more in common use in countries poorer in natural resources like the UK. This is where high quality recycled materials are produced.

The scarcity of recovered material and the lack of standards for their evaluation is what inhibits architects in Austria from using them at the moment.

7. Record keeping

Architects according to the findings from the interviews keep record for all quantities of the materials used to construct a building, because it is obligatory by the urban design department. The responsibility of the materials list rests with the owner after the construction of the building so that it may be used for future renovations or demolition.

8. Impediments towards Design for Deconstruction

The main obstacle for the use of demountable components impediment to apply demountable predefined components, recovered material and other DfD practices is the lack of quality standards which would have facilitated their wider use. It is the standardization of the techniques and materials which will make the Design for Deconstruction familiar and more convenient to the architectural offices.

5.5 General conclusions

The main objective of this research is on one hand the environmental protection against pollution caused by the huge amount of demolition waste containing toxic substances. On the other hand, the main concern of this thesis is to allow energy and cost savings on the overall economy level by reusing the demolition waste.

In order to achieve those objectives the parties involved with the creation of the problem (the state, the public, the designers and the waste treatment companies) should become aware and sensitized about its resolution. In addition, these parties should cooperate with each other and a number of rules, laws and guidelines should be official established and applied.

The most important findings of this research in the literature is that construction materials and components should be designed with an aim of their return either to the biological or to the technical sphere at the end of their lifecycle, as stated by William Mc Donough and Michael Braungart in their book Cradle to Cradle. We do not know for sure the state of the art of the technology in 30 or more years when the buildings we design today will be demolished, but we have to take seriously into consideration the ability of the demolition material to be separated from each other, after the end of the building's technical life and the reusability of this material stream for other purposes. Material resources are not endless and contemporary design must avoid composite material because the higher the mixture of the materials in a building, the more energy we need to take them apart. Regardless of the demolition strategy , there are 4 principles which cannot be ignored:

- Biodegradable material can be disposed in landfills,
- Technically useful material like wood and metals must be recycled or even better reused to serve the technical needs of the industry.
- Composite materials like plastics, should remain in use as long as their technical lifetime lasts i.e. some hundred years. By no means should they be mixed with biodegradable material and be disposed in landfills because with time they become toxic and do not serve the purpose they were produced for.
- The use of toxic materials like the heavy metals should be avoided, especially in their dispersed form. But if used, they should be easily separated from the demolition materials, so that they are properly stored or treated as a special waste.

" Treating the waste is not the solution, avoiding creating it is the answer ".

chapter 6

REFERENCES

6.1 LITERATURE

Baccini, P. (cd.), 1989, *The Landfill-Reactor and Final Storage*, Berlin, Germany: Springer Verlag.

Bilitewski, B., Gewiese A., Marek K., 1994, *Abfallwirtschaft 2. Auflage* Berlin, Springer Verlag

Brunner, P. H., Stämpfli, D. M., 2003, *Material Balance of a Construction Waste Sorting Plant*, Waste Management & Research 1, Vol. 11, p. 27-48

Bundesministerium für Land- und Fortswirtschaft, Umwelt und Wasserschafft, *Bundes-Abfallwirtschaftsplan 2011*, Wien, p. 2011, p.17-20, 81-88.

Chini, A. R., 2005, *Deconstruction and Materials Reuse, an International Overview*, International Council for Research and Innovation in Building Construction (CIB), Publication, p. 300, 54-90, 162-180, 287- 305.

Dallmann, W., Uhlig, D., *Aufbereitung von Bauabfällen, Alternative Möglichkeiten*, in *Baustoff Recycling + Deponietechnik 5/99*, p. 22-26.

Directive 2008/98/EC of the European Parliament and of the Council, p. 163.

Durmisevic, E., 2006, *Transformable Building Structures*, Thesis (PhD), University of Delft, p. 25-34

Environmental Protection Agency (EPA), 2008, *Lifecycle Construction Resource Guide*, Atlanta, p. 15-16.

EnBa Schadstoffkatalog, Ressourcen Management Agentur, 09/2011, p.1

Fischer, C., Werge, M., 2009, *EU as a Recycling Society*, ETC/SCP working paper 2/2009

Graedel & B.R.Allenby, 1996, *Design for Environment*, Prentice Hall

Kibert, C., Sendzimir, J., Brad, G., 2002, University of Florida, *Construction ecology and metabolism. Conference Proceedings*

McDonough, W., Braungart, M., 2009, *Cradle to cradle : remaking the way we make things*, Vintage Books, London, p. 57-58,92,106,168-177.

Morgan C., and Stevenson F., 2005, *Design and Detailing for deconstruction*, SEDA Design Guide for Scotland, 9, p. 23-31

Osebold, R., *Abbruch von Massivbauwerken*, Verlagsgesellschaft Rudolf Müller, Köln-Braunsfeld, 1981

Raess, C., Rentz, O., Seemann, A., Schultmann, F., 2003 *Entwicklung optimierter Rückbau- und Recyclingverfahren durch Kopplung von Gebäudedemontage und Bauschutttaufbereitung*, Karlsruhe, p. 39-47, 55-58, 60-86.

Report to DGXI, *European Commission, Construction and Demolition Waste Management Practices and their economic impacts*, Final Report, February 1999, p.1-6

Roussat, N., Dujet, C., Mehu, J., *Choosing a sustainable Waste Management Strategy*, online article, 2008, p.15

Rosato, D. V. (1972) *Current and future trends for mass producing plastic parts in the building industry*. in *Plastics in Building Construction*, National Technical Conference, Society of Plastics Engineers, November 8-10, Pittsburgh, PA, U.S.A. p. 37-48.

Scheibengraf M., Reisinger, H., 2006, *Abfallvermeidung und Verwertung: Baurestmassen*, Wien, p.25-35

Stahl, J. A. & Tanzilli, J. D. (1972) Vinyl plastics, a prime building material. in *Plastics in Building Construction*, National Technical Conference, Society of Plastics Engineers, November 8-10, Pittsburgh, PA, U.S.A, p. 15-25

Thormark, C., 2000, *Environmental analysis of Building with reused building materials*

Tomas, J., 1999, *Aufschließen und Abtrennen von Wertstoffen aus Bauschutt*. Teil 2: *Sortierung aufgeschlossener und teilgeschlossener Bruchstücke*, *Entsorgungspraxis* 12/99, p.16-20

Westra, J., 1990, *Toesen traditie en experiment Over Ontwerpers, ontwikkelaars en ondernemers in de bouw*, uitgeverij 010, Rotterdam

Wilson, D. G., 1975, *The resource potential of demolition debris in the U.S. Resource Recovery and Conservation*, p.11, 129-140.

6.2. WEB PAGES

<http://en.wikipedia.org/wiki/Incineration> (visited on Sept. 2011)

<http://www.lifecyclebuilding.org/files/DFD.pdf> (visited Sept. 2011)

<http://www.design4deconstruction.org/index.html> (visited Oct. 2011)

http://www.shibang-china.com/info/Impact_Crusher.html (visited Oct. 2011)

<http://en.wikipedia.org/wiki/Asbestos> (visited Oct. 2011)

<http://www.jawcrushermanufacturers.com> (visited Nov.2011)

<http://www.break-day.com/ver3.0/how/5.htm> (visited Nov.2011)

<http://www.stonecrusher.org/stonecrusher1.0/crushingmachinery/impact-crusher.html> (visited Nov..2011)

<http://www.scribd.com/doc/30156582/Chapter-6-Roll-Crushers>(visited Sept. 2011)

<http://www.hjcrusher.com/2-cone-crusher-7.html> (visited Sept .2011)

http://en.wikipedia.org/wiki/Incineration#Arguments_against_incineration (visited Sept. 2011)

<http://en.wikipedia.org/wiki/Landfill> (visited Sept. 2011)

6.3. TABLES

Table 2.1 Table with hazardous construction materials . (Roussat, Dujet, Méhu 2008).....	12
Table 2.2 Comparison between dry and wet classifiers (Raess et al. 2003).....	30
Table 3.1 Connection types (Morgan C. and Stevenson F. 2005).....	41
Table 3.2. Bill of materials for residential building (Schultmann Frank, CIB. 2005).....	50
Table 3.3 Hazardous Construction Waste and reused percentages (CIB 2005).....	53
Table 3.4 Hazardous waste Catalogue in Austria (source Abfallwirtschaftsplan 2011).....	67
Table 3.5 Treatment of dangerous waste in Austria (source Abfallwirtschaftsplan 2011).....	68

6.4. FIGURES

Figure 1.1 Relation between the state of the technological development and the consumption of natural resources (Greadel and Allenby 1996).....	14
Figure 1.2 Materials used in the USA the last century (Wilson 1990).....	7
Figure 1.3. Use of plastics for various construction purposes (Rosato 1972 and Stahl 1972)	9

Figure 2.1 Pulling with tractor and cable (Osebold 1981).....	14
Figure 2.2 Pushing with hydraulic machine unit (Osebold 1981).....	14
Figure 2.3 Tearing with hydraulic machine unit (Osebold 1981).....	15
Figure 2.4 Grabbing and Pulling with pliers and scissors (Abbruch Handbuch 1985).....	15
Figure 2.5 Down leveling with drills and hammers (Osebold 1981).....	16
Figure 2.6 Building components of the Lustron-house, Albany, New York (Westra J. 1990).....	17
Figure 2.7 Composition of residential waste (CIB 2005).....	18
Figure 2.8 Manual sorting (Schultmann et al. 2003).....	19
Figure 2.9 Sorting with grippers . (Schultmann et al. 2003).....	19
Figure 2.10 Jaw crusher (http://www.jawcrushermanufacturers.com).....	21
Figure 2.11 Impact crusher (http://www.break-day.com/ver3.0/how/5.htm).....	22
Figure 2.12 Impact crusher (http://www.stonecrusher.org/stonecrusher1.0/crushingmachinery/impact-crusher.html).....	22
Figure 2.13 Roll crusher (http://www.scribd.com/doc/30156582/Chapter-6-Roll-Crushers).....	22
Figure 2.14 Cone crusher (http://www.hjcrusher.com/2-cone-crusher-7.html).....	23
Figure 2.15 Counter flow classifier (Bilitewski 1995).....	25
Figure 2.16 Crossflow classifier (Bilitewski 1995).....	26
Figure 2.17 Zick-Zack classifier (Tomas 1999).....	26
Figure 2.18 Elasticity classifier with plate (Dallmann 1999).....	27
Figure 2.17 Zick-Zack classifier (Tomas 1999).....	26
Figure 2.18 Elasticity classifier with plate (Dallmann 1999).....	27
Figure 2.19 Elasticity classifier with rolling drum (Dallmann 1999).....	27
Figure 2.20 Elasticity classifier with inclined belt (Dallmann 1999).....	28
Figure 2.21 Hydroband separator (Dallmann 1999).....	29
Figure 2.22 Washing drum (Dallmann 1999).....	30
Figure 2.23 The Spittelau incineration plant in Vienna, designed by Friedensreich Hundertwasser (wikipedia 2011).....	32
Figure 2.24 Landfil (wikipedia 2011).....	33
Figure 2.25 Gradation between best and worst waste treatment with blue representing the best and red the worst (http://www.lifecyclebuilding.org/files/DFD.pdf).....	33
Figure 3.1 Linear building scenario and closed loop building scenario (Durmisevic 2006).....	35
Figure 3.2 Different layers of the building structure have different life cycles (Durmisevic 2006).....	36
Figure 3.3 Flexibility of the building plan ensures longer life cycle and functional rearrangements (Morgan C. & Stevenson F. 2005).....	40
Figure 3.4 Building layers should be independent from each other and easily accessible to be removed or repaired. (Morgan C. and Stevenson F. 2005).....	40

Figure 3.5 Concrete and masonry crushed aggregates (Scheibengraf M. & Reisinger H. 2006).....	41
Figure 3.6 Concrete and masonry crushed aggregates (Scheibengraf M. & Reisinger H. 2006).....	43
Figure 3.7 Cellulose Insulation (wikipedia 2011).....	44
Figure 3.8 Cellulose Insulation (wikipedia 2011).....	44
Figure 3.9 Fibrous Asbestos on muscovite (wikipedia 2011).....	45
Figure 3.10 Demolition Pre-planning process (CIB 2005).....	49
Figure 3.11 Deconstruction duration schedule (CIB 2005).....	50
Figure 3.12 Demolition Optimization Software input data 1 (CIB 2005).....	51
Figure 3.13 Demolition Optimization Software input data 2 (CIB 2005).....	51
Figure 3.14 Demolition Optimization Software Result Analysis (CIB 2005).....	52
Figure 3.15 Hazardous Waste European Overview (DEFRA 2011).....	54
Figure 3.16 Recycling of construction and demolition waste per capita in the EU and Norway(Fischer, C., Werge, M.,2009).....	56
Figure 3.17 Composition in tones of recycled construction and demolition waste in the EU and Norway. (Fischer, C., Werge, M.,2009)..	57
Figure 3.18 Muhlhouse project (CIB. 2005).....	58
Figure 3.19 Comparison between conventional and selective demolition in Mulhouse(CIB. 2005).....	59
Figure 3.20 Delta BMB system bolted or steel-strip connections between concrete elements (CIB 2005.....	59
Figure 3.21 Middelburg apartment complex(CIB2005).....	60
Figure 3.22 Waste generation in the UK (DEFRA 2011).....	60
Figure 3.23 Construction and demolition waste generation in the UK (Defra-2011).....	61
Figure 3.24 Second hand windows, tiles and sanitary equipment sold a t the local market in Turkey (CIB 2005).....	62
Figure 3.25 Distribution of waste in Austria into several categories (source Abfallwirtschaftsplan 2011.....	63
Figure 3.26 Proportion of construction waste landfilled, treated or stored (Abfallwirtschaftsplan 2011).....	63
Figure 3.27 Composition of Construction waste in Austria (Abfallwirtschaftsplan 2011).....	64
Figure 3.28 Treatment of Construction waste in Austria (Abfallwirtschaftsplan 2011).....	64
Figure 3.29 Arise of Asbestos and Asbestos cement dust in Austria (Abfallwirtschaftsplan 2011).....	65
Figure 3.30 Deposited Asbestos Waste in Austria (Abfallwirtschaftsplan 2011).....	65
Figure 5.1 Selective Demolition. removal of toxic material (EnBa Schaddstoffkatalog 2011)	91